

(54) Title of the invention : AN ASSISTIVE MOBILE APPLICATION FOR THE VISUALLY IMPAIRED PEOPLE

(51) International classification :H04L0029060000, G06F0021620000, H04L0029080000, H04L0009320000, H04L0009080000

(86) International Application No :NA
 Filing Date :NA

(87) International Publication No : NA

(61) Patent of Addition to Application Number :NA
 Filing Date :NA

(62) Divisional to Application Number :NA
 Filing Date :NA

(71)Name of Applicant :
1)HINDUSTHAN COLLEGE OF ENGINEERING AND TECHNOLOGY
 Address of Applicant :HINDUSTHAN COLLEGE OF ENGINEERING AND TECHNOLOGY, VALLEY CAMPUS, POLLACHI HIGHWAY, COIMBATORE, TAMIL NADU, INDIA - 641032. -----
Name of Applicant : NA
Address of Applicant : NA

(72)Name of Inventor :
1)Dr. I. JASMINE SELVAKUMARI JEYA
 Address of Applicant : PROFESSOR & HEAD-IT, HINDUSTHAN COLLEGE OF ENGINEERING AND TECHNOLOGY, VALLEY CAMPUS, POLLACHI HIGHWAY, COIMBATORE, TAMIL NADU, INDIA - 641032. -----
 --
2)Dr. B. GOMATHI
 Address of Applicant :ASSOCIATE PROFESSOR/ IT, HINDUSTHAN COLLEGE OF ENGINEERING AND TECHNOLOGY, VALLEY CAMPUS, POLLACHI HIGHWAY, COIMBATORE, TAMIL NADU, INDIA - 641032. ----

3)RANJITH S
 Address of Applicant :HINDUSTHAN COLLEGE OF ENGINEERING AND TECHNOLOGY, VALLEY CAMPUS, POLLACHI HIGHWAY, COIMBATORE, TAMIL NADU, INDIA - 641032. -----
4)RISHI M
 Address of Applicant :HINDUSTHAN COLLEGE OF ENGINEERING AND TECHNOLOGY, VALLEY CAMPUS, POLLACHI HIGHWAY, COIMBATORE, TAMIL NADU, INDIA - 641032. -----
5)RITHICKISHORE R M
 Address of Applicant :HINDUSTHAN COLLEGE OF ENGINEERING AND TECHNOLOGY, VALLEY CAMPUS, POLLACHI HIGHWAY, COIMBATORE, TAMIL NADU, INDIA - 641032. -----
6)SANJAY RAJ A
 Address of Applicant :HINDUSTHAN COLLEGE OF ENGINEERING AND TECHNOLOGY, VALLEY CAMPUS, POLLACHI HIGHWAY, COIMBATORE, TAMIL NADU, INDIA - 641032. -----

(57) Abstract :
 Due to the rapid growth of cloud computing, many individuals and enterprises are opting to move their local data to cloud servers. When enterprises ; outsource their data to a public cloud, they face tremendous security and privacy 'concern's (e.g., data breach, data loss, and data confidentiality violation) due to entrusted cloud environments: This project focuses on guaranteeing data security and privacy while sharing sensitive data in a cloud environment across the same or .distinct Organizations. This project creates a Blockchain-based privacy-preserving . framework that ensures the security, privacy, scalability, and integrity of cloud data. Furthermore, the data in cloud environment is encrypted with a cryptographically . secure public key encryption technique, resulting in a secure Blockchain solution for data-in the cloud. The goal of the project is to lay the groundwork for developing : security solutions against cyber-attacks by leveraging intrinsic properties of Blockchain, and also contribute to the robustness of data exchange across contexts.

No. of Pages : 5 No. of Claims : 5

पेटेंट कार्यालय
शासकीय जर्नल

**OFFICIAL JOURNAL
OF
THE PATENT OFFICE**

निर्गमन सं. 51/2019
ISSUE NO. 51/2019

शुक्रवार
FRIDAY

दिनांक: 20/12/2019
DATE: 20/12/2019

पेटेंट कार्यालय का एक प्रकाशन
PUBLICATION OF THE PATENT OFFICE

INTRODUCTION

In view of the recent amendment made in the Patents Act, 1970 by the Patents (Amendment) Act, 2005 effective from 01st January 2005, the Official Journal of The Patent Office is required to be published under the Statute. This Journal is being published on weekly basis on every Friday covering the various proceedings on Patents as required according to the provision of Section 145 of the Patents Act 1970. All the enquiries on this Official Journal and other information as required by the public should be addressed to the Controller General of Patents, Designs & Trade Marks. Suggestions and comments are requested from all quarters so that the content can be enriched.

(Om Prakash Gupta)
CONTROLLER GENERAL OF PATENTS, DESIGNS & TRADE MARKS

20TH DECEMBER, 2019

CONTENTS

<i>SUBJECT</i>	<i>PAGE NUMBER</i>
JURISDICTION	: 60966 – 60967
SPECIAL NOTICE	: 60968 – 60969
LIST OF HOLIDAYS FOR THE YEAR-2020 (ENGLISH)	: 60970
LIST OF HOLIDAYS FOR THE YEAR-2020 (HINDI)	: 60971
EARLY PUBLICATION (DELHI)	: 60972 – 60236
EARLY PUBLICATION (MUMBAI)	: 61237 – 61288
EARLY PUBLICATION (CHENNAI)	: 61289 – 61408
EARLY PUBLICATION (KOLKATA)	: 61409 – 61419
PUBLICATION AFTER 18 MONTHS (DELHI)	: 61420 – 61659
PUBLICATION AFTER 18 MONTHS (MUMBAI)	: 61660 – 62108
PUBLICATION AFTER 18 MONTHS (CHENNAI)	: 62109 – 62401
PUBLICATION AFTER 18 MONTHS (KOLKATA)	: 62402 – 62565
WEEKLY ISSUED FER (DELHI)	: 62566 – 62606
WEEKLY ISSUED FER (MUMBAI)	: 62607 – 62629
WEEKLY ISSUED FER (CHENNAI)	: 62630 – 62674
WEEKLY ISSUED FER (KOLKATA)	: 62675 – 62688
PUBLICATION UNDER SECTION 43(2) IN RESPECT OF THE GRANT (DELHI)	: 62689 – 62704
PUBLICATION UNDER SECTION 43(2) IN RESPECT OF THE GRANT (MUMBAI)	: 62705 – 62711
PUBLICATION UNDER SECTION 43(2) IN RESPECT OF THE GRANT (CHENNAI)	: 62712 – 62728
PUBLICATION UNDER SECTION 43(2) IN RESPECT OF THE GRANT (KOLKATA)	: 62729 – 62734
INTRODUCTION TO DESIGN PUBLICATION	: 62735
THE DESIGNS ACT, 2000 SECTION 30 DESIGN ASSIGNMENT	: 62736
REGISTRATION OF DESIGNS	: 62737 - 62804

**THE PATENT OFFICE
KOLKATA, 20/12/2019**

Address of the Patent Offices/Jurisdictions

The following are addresses of all the Patent Offices located at different places having their Territorial Jurisdiction on a Zonal basis as shown below:-

<p>1 Office of the Controller General of Patents, Designs & Trade Marks, Boudhik Sampada Bhavan, Near Antop Hill Post Office,S.M.Road,Antop Hill, Mumbai - 400 037</p> <p>Phone: (91)(22) 24123311, Fax : (91)(22) 24123322 E-mail: cgpdtm@nic.in</p>	<p>4 The Patent Office, Government of India, Intellectual Property Rights Building, G.S.T. Road, Guindy, Chennai - 600 032.</p> <p>Phone: (91)(44) 2250 2081-84 Fax : (91)(44) 2250 2066 E-mail: chennai-patent@nic.in</p> <p>❖ The States of Andhra Pradesh, Telangana, Karnataka, Kerala, Tamil Nadu and the Union Territories of Puducherry and Lakshadweep.</p>
<p>2 The Patent Office, Government of India, Boudhik Sampada Bhavan, Near Antop Hill Post Office,S.M.Road,Antop Hill, Mumbai - 400 037</p> <p>Phone: (91)(22) 24137701 Fax: (91)(22) 24130387 E-mail: mumbai-patent@nic.in</p> <p>❖ The States of Gujarat, Maharashtra, Madhya Pradesh, Goa and Chhattisgarh and the Union Territories of Daman and Diu & Dadra and Nagar Haveli</p>	<p>5 The Patent Office (Head Office), Government of India, Boudhik Sampada Bhavan, CP-2, Sector -V, Salt Lake City, Kolkata- 700 091</p> <p>Phone: (91)(33) 2367 1943/44/45/46/87 Fax: (91)(33) 2367 1988 E-Mail: kolkata-patent@nic.in</p> <p>❖ Rest of India</p>
<p>3 The Patent Office, Government of India, Boudhik Sampada Bhavan, Plot No. 32., Sector-14, Dwarka, New Delhi - 110075</p> <p>Phone: (91)(11) 25300200 & 28032253 Fax: (91)(11) 28034301 & 28034302 E.mail: delhi-patent@nic.in</p> <p>❖ The States of Haryana, Himachal Pradesh, Jammu and Kashmir, Punjab, Rajasthan, Uttar Pradesh, Uttaranchal, Delhi and the Union Territory of Chandigarh.</p>	

Website: www.ipindia.nic.in

www.patentoffice.nic.in

All applications, notices, statements or other documents or any fees required by the Patents Act, 1970 and The Patents (Amendment) Act, 2005 or by the Patents (Amendment) Rules, 2006 will be received only at the appropriate offices of the Patent Office.

Fees: The Fees may either be paid in cash or may be sent by Bank Draft or Cheques payable to the Controller of Patents drawn on a scheduled Bank at the place where the appropriate office is situated.

पेटेंट कार्यालय
कोलकाता, दिनांक 20/12/2019

• कार्यालयों के क्षेत्राधिकार के पते

विभिन्न जगहों पर स्थित पेटेंट कार्यालय के पते आंचलिक आधार पर दर्शित उनके प्रादेशिक अधिकार क्षेत्र के साथ नीचे दिए गए हैं:-

<p>1 कार्यालय : महानियंत्रक, एकस्व, अभिकल्प तथा व्यापार चिह्न, एंटोप हिल डाकघर के समीप, एस. एम. रोड, एंटोप हिल, मुम्बई- 400 037, भारत, फोन: (91) (22) 24123311 फ़ैक्स: (91) (22) 24123322 ई. मेल: cgpdmt@nic.in</p>	<p>4 पेटेंट कार्यालय, भारत सरकार इंटेलेक्चुअल प्रॉपर्टी राइट्स बिल्डिंग, इंडस्ट्रियल इस्टेट एसआईडीसीओ आरएमडी गोडाउन एरिया एडजसेन्ट टु ईगल फ्लास्क, जी. एस. टी. रोड, गायन्डी चेन्नई - 600 032. फोन: (91) (44) 2250 2081-84 फ़ैक्स: (91) (44) 2250-2066 ई. मेल: chennai-patent@nic.in ❖ आन्ध्र प्रदेश, तेलंगाना, कर्नाटक, केरल, तमिलनाडु तथा पुडुचेरी राज्य क्षेत्र एवं संघ शासित क्षेत्र, लक्षदीप</p>
<p>2 पेटेंट कार्यालय, भारत सरकार बौद्धिक संपदा भवन, एंटोप हिल डाकघर के समीप, एस. एम. रोड, एंटोप हिल, मुम्बई- 400 037, फोन: (91) (22) 24137701 फ़ैक्स: (91) (22) 24130387 ई. मेल: Mumbai-patent@nic.in ❖ <input type="checkbox"/> गुजरात, महाराष्ट्र, मध्य प्रदेश, गोवा तथा छत्तीसगढ़ राज्य क्षेत्र एवं संघ शासित क्षेत्र, दमन तथा दीव, दावर और नगर हवेली.</p>	<p>5 पेटेंट कार्यालय, भारत सरकार कोलकाता, (प्रधान कार्यालय) बौद्धिक संपदा भवन, सीपी-2, सेक्टर- V, साल्ट लेक सिटी, कोलकाता-700 091, भारत. फोन: (91) (33) 2367 1943/44/45/46/87 फ़ैक्स:/Fax: (91) (33) 2367 1988 ई. मेल: kolkata-patent@nic.in ❖ भारत का अवशेष क्षेत्र</p>
<p>3 पेटेंट कार्यालय, भारत सरकार बौद्धिक संपदा भवन, प्लॉट सं. 32, सेक्टर- 14, द्वारका, नई दिल्ली- 110 075. फोन: (91) (11) 25300200, 28032253 फ़ैक्स: (91) (11) 28034301, 28034302 ई. मेल: delhi-patent@nic.in हरियाणा, हिमाचल प्रदेश, जम्मू तथा कश्मीर, पंजाब, राजस्थान, उत्तर प्रदेश, दिल्ली तथा उत्तरांचल राज्य क्षेत्रों, एवं संघ शासित क्षेत्र चंडीगढ़</p>	

वेबसाइट: <http://www.ipindia.nic.in>
www.patentoffice.nic.in

पेटेंट अधिनियम, 1970 तथा पेटेंट (संशोधन) अधिनियम, 2005 अथवा पेटेंट (संशोधन) नियम, 2006 द्वारा वांछित सभी आवेदन, सूचनाएं, विवरण या अन्य दस्तावेज़ या कोई शुल्क पेटेंट कार्यालय के केवल उपयुक्त कार्यालय में स्वीकृत होंगे। शुल्क: शुल्क या तो नगद रूप में या Controller of Patents के नाम में देय बैंक ड्राफ्ट या चेक के द्वारा भेजी जा सकती है जो उसी स्थान के किसी अनुसूचित बैंक में प्रदत्त हो जहाँ उपयुक्त कार्यालय स्थित है।

SPECIAL NOTICE

18 Months publication as required under Section 11A of the Patents Act, 1970 as amended by the Patents (Amendment) Act, 2005.

Notice is hereby given that any person at any time before the grant of Patent may give representation by way of opposition to the Controller of Patents at appropriate office on the ground and in a manner specified under section 25(1) of the Patents (Amendment) Act, 2005 read with Rule 55 of the Patents (Amendment) Rules, 2006.

Notice is also given that if any interested person requests for copies of the complete specification, drawing and abstract of any application already published, the photocopy of the same can be supplied by the Patent Office as per the jurisdiction on payment of prescribed fees of Rs.8/- per page. If any further details are required to be obtained, the same can be provided by the respective Patent Offices on request.

(Om Prakash Gupta)
CONTROLLER GENERAL OF PATENTS, DESIGNS & TRADE MARKS

SPECIAL NOTICE

Under the new provision of the Patents Act, 1970 as amended by the Patents (Amendment) Act, 2005 and Rules there under, Publication of the matter relating to Patents in the Official Gazette of India Part III, Section 2 has been discontinued and instead The Official Journal of the Patent Office is being published containing all the activities of The Patent Office such as publication of all the patent applications after 18th months , grant of patents & all other information in respect of the proceedings as required under the provisions of the Patents (Amendment) Act, 2005 and Rules thereunder on weekly basis on every **Friday**.

The Journal is uploaded in the website every Friday. So Paper form and CD-ROM form of the Journal are discontinued from 01/01/2009.

SPECIAL NOTICE

Every effort is being taken to publish all the patent applications under section 11(A) of the Patents Act. However, if duplication of publication of any application is found, then earlier date of publication will be taken for the purpose of provisional protection for applicant and Patent Office will grant Patent not before six months from the date of second publication, provided that there is there is no third party representation.

LIST OF RESTRICTED HOLIDAYS FOR THE YEAR - 2020

In addition to the declared Holidays each members of the staffs of this office may also be permitted to avail of any two holidays to be chosen by him/her out of the Restricted Holidays given below, after giving prior intimation.

	Restricted Holidays & Connected Festivals	Month & Date	Days of Week
1.	New Years Day	January 01	Wednesday
2.	Guru Govind Singh's Birthday	January 02	Thursday
3.	Lohri	January 13	Monday
4.	Makar Sankranti/Pongal	January 15	Wednesday
5.	Pongal	January 15	Tuesday
6.	Netaji Subhash Chandra Bose's birthday	January 23	Thursday
7.	Guru Ravidas's Birthday	February 09	Sunday
8.	Swami Dayananda Saraswati's Birth Day	February 18	Tuesday
9.	Shivaji Jayanti	February 19	Wednesday
10.	Maha Shivaratri	February 21	Friday
11.	Holika Dahan/Dolyatra	March 09	Monday
12.	Hazrat Ali,s Birthday	March 09	Monday
13.	ChaitraSukladi/Gudi Padava/Ugadi/Cheti Chand	March 25	Wednesday
14.	Easter Sunday	April 12	Sunday
15.	Vaisakhi/Vishu	April 13	Monday
16.	Mesadi/Vaisakhadi (Bengal)/Bahag Bihu (Assam)	April, 14	Tuesday
17.	Guru Rabindranath's birthday	May 08	Friday
18.	Jamat-ul-vida	May 22	Friday
19.	Rath Yatra	June 23	Tuesday
20.	Raksha Bandhan	August 03	Monday
21.	Janmashtami	August 11	Tuesday
22.	Parsi New Year's day/Nauraj	August 16	Sunday
23.	Vinayaka Chaturthi/Ganesh Chaturthi	August 22	Sunday
24.	Onam or Thiru Onam day	August 31	Monday
25.	Dussehra(Maha Ashtami) (Maha Nabami) (Additional)	October 24	Saturday
26.	Vijay Dashmi (Bengal, Kerala)	October 26	Monday
27.	Maharshi Valmiki's Birthday	October 31	Saturday
28.	Karaka Chaturthi (Karva Chouth)	November 04	Wednesday
29.	Naraka Chaturdasi	November 14	Saturday
30.	Govardhan Puja	November 15	Sunday
31.	Bhai Duj	November 16	Monday
32.	Pratihara Shashthi or Surya Shashthi (Chhat Puja)	November 20	Friday
33.	Guru Tegh Bahadur's Martyrdom Day	November 24	Tuesday
34.	Christmas Eve	December 24	Thursday

(Sanjay Bhattacharya)
Dy. Controller of Patents & Designs
& Head of Office



बौद्धिक सम्पदा भारत
एकस्व/अभिकल्प/व्यापार चिह्न
भौगोलिक संकेत/पेटेंट सूचना पद्धति
INTELLECTUAL PROPERTY
INDIA
Patents/Designs/Trade Marks
Geographical Indications/
Patent Information System



भारत सरकार
GOVERNMENT OF INDIA
पेटेंट कार्यालय
THE PATENT OFFICE

बौद्धिक सम्पदा भवन/BOUDDHIK SAMPADA BHAWAN
सीपी-२/CP-2, सेक्टर- V/ Sector-V, साल्ट लेक/SALT LAKE
कोलकाता/KOLKATA- 700 091.
दूरभाष/Tel : (91)(33)2367 1943-46
: (91)(33)2367 1987(D),

संख्या/No. : एच-45011/1/2004-प्रशासन

दिनांक/Date: 10-12-2019

वर्ष 2020 में छुट्टियों की सूची

वर्ष 2020 के दौरान पेटेंट कार्यालय, कोलकाता के लिए निम्नलिखित दिनों को छुट्टी घोषित किया गया है।

क्र.सं.	छुट्टियाँ तथा संबंधित त्यौहार	दिनांक	सप्ताह के दिन
1.	गणतंत्र दिवस	जनवरी, 26	रविवार
2.	वसंत पंचमी/श्री पंचमी	जनवरी, 30	गुरुवार
3.	होली	मार्च, 10	मंगलवार
4.	महावीर जयंती	अप्रैल, 06	सोमवार
5.	गुड फ्राइडे	अप्रैल, 10	शुक्रवार
6.	बुद्ध पुर्णिमा	मई, 07	गुरुवार
7.	ईद-उल-फितर	मई, 25	सोमवार
8.	ईद-उल-जुहा (बकरीद)	अगस्त, 01	शनिवार
9.	स्वतंत्रता दिवस	अगस्त, 15	शनिवार
10.	मुहर्रम	अगस्त, 30	रविवार
11.	महात्मा गाँधी जयंती	अक्तुबर, 02	शुक्रवार
12.	दशहरा (महा सप्तमी) (अतिरिक्त)	अक्तुबर, 23	शुक्रवार
13.	दशहरा	अक्तुबर, 25	रविवार
14.	मिलाद-उन-नबी या ईद-ए-मिलाद (प्रोफेट मोहम्मद जन्मदिवस)	अक्तुबर, 30	शुक्रवार
15.	दिवाली (दिपावली)	नवम्बर, 14	शनिवार
16.	गुरुनानक जयंती	नवम्बर, 30	सोमवार
17.	क्रिसमस डे	दिसम्बर, 25	शुक्रवार

टिप्पणी: केन्द्र सरकार के संस्थानों में, जिनमें औद्योगिक, वाणिज्यिक तथा प्रशिक्षण प्रतिष्ठान (यथा सचिवालयी प्रवृत्ति से पृथक कार्य कराने वाले) शामिल हैं, इस वर्ष 16 अवकाश होंगे जिनमें से 3 (तीन) यथा गणतंत्र दिवस, स्वतंत्रता दिवस तथा महात्मा गाँधी जयंती अनिवार्य होंगे। शेष अवकाश/अवसर उन प्रतिष्ठानों/संस्थानों द्वारा प्रत्येक वर्ष स्वयं निर्धारित किए जायेंगे।

कोई विशेष/प्रतिष्ठान/संगठन औद्योगिक, वाणिज्यिक एवं व्यापारिक प्रतिष्ठान (अर्थात् सचिवालयीय प्रवृत्ति के कार्य करने वाले प्रतिष्ठानों के अतिरिक्त) है कि नहीं इसका निर्धारण संबंधित मंत्रालय/गृह मंत्रालय, नई दिल्ली द्वारा किया जाएगा।

मुस्लिम त्यौहारों की छुट्टी के दिन चाँद के दिखने तथा राज्य सरकार द्वारा लिए गए निर्णय के आधार पर बदले जा सकते हैं।

(संजय भट्टाचार्य)
उप नियंत्रक एकस्व एवं अभिकल्प
तथा कार्यालय प्रधान

Early Publication:

The following patent applications have been published under section 11A (2) of The Patents (Amendment) Act 2005 and rule 24A of The Patents (Amendment) Rules, 2006. Any person may file representation by way of opposition to the Controller of Patents at the appropriate office against the grant of the patent in the prescribed manner under section 25(1) of the Patents (Amendment) Act 2005 read with the rule 55 of The Patents (Amendment) Rules, 2006:

(12) PATENT APPLICATION PUBLICATION

(21) Application No.201811034650 A

(19) INDIA

(22) Date of filing of Application :14/09/2018

(43) Publication Date : 20/12/2019

(54) Title of the invention : I-SECURITY: INTELLIGENT HOME SECURITY USING VIBRATION SENSOR AND RFID KIT

(51) International classification	:H04L29/08	(71)Name of Applicant :
(31) Priority Document No	:NA	1)DR. VUPPU PADMAKAR
(32) Priority Date	:NA	Address of Applicant :H. NO. 3-112/27/6, BHEEMREDDY
(33) Name of priority country	:NA	NAGAR, BODUPPAL, RANGAREDDY DIST., HYDERABAD-
(86) International Application No	:NA	500092, TELANGANA Telangana India
Filing Date	:NA	2)DR. B V RAMANA MURTHY
(87) International Publication No	: NA	3)MR. C. KISHORE KUMAR REDDY
(61) Patent of Addition to Application Number	:NA	4)MRS. P R ANISHA
Filing Date	:NA	5)PROF. DR. BIPLAB KUMAR SARKAR
(62) Divisional to Application Number	:NA	(72)Name of Inventor :
Filing Date	:NA	1)DR. VUPPU PADMAKAR
		2)DR. B V RAMANA MURTHY
		3)MR. C. KISHORE KUMAR REDDY
		4)MRS. P R ANISHA
		5)PROF. DR. BIPLAB KUMAR SARKAR

(57) Abstract :

Security is very essential now days as most people are at work and their homes remain closed for most of the time. So a need of a security system even when we are away from it is essential. In our project we are trying to provide a security system through which the owner and the members can keep an eye on their home while being away from it. This system uses a vibration sensor for monitoring vibrations. Vibrations occur when a thief or unwanted entry tries to break in the door/window and tries to enter. The controller senses the vibrations and sends the values to Raspberry Pi and beagle- Bone one kit. The Raspberry pi , beagle Bone checks the values and compares with the desired set of values. If the input value is greater than the threshold value then it turns ON a buzzer and the Raspberry Pi controller sends a message and an email to the desired owners of the system and the security department and it starts the video capturing of the scene. The owner can then live stream the video by simply typing the IP address of the Pi controller in the web browser. In this way the owner can take desired actions in the future.

No. of Pages : 16 No. of Claims : 6

(12) PATENT APPLICATION PUBLICATION

(21) Application
No.201811039743 A

(19) INDIA

(22) Date of filing of Application :22/10/2018

(43) Publication Date :
20/12/2019

(54) Title of the invention : SYSTEM FOR CATARACT DETECTION AND METHOD THEREOF

(51)
International :G06K0009000000,G06K0009200000,G06F0003010000,H01M0016000000,A61B0005117000
classification
(31) Priority
Document :NA
No
(32) Priority :NA
Date
(33) Name
of priority :NA
country
(86)
International
Application :NA
No :NA
Filing
Date
(87)
International
Publication : NA
No
(61) Patent
of Addition
to
Application :NA
Number :NA
Filing
Date
(62)
Divisional to
Application :NA
Number :NA
Filing
Date

(71)Name of Applicant
:
**1)THE
REGISTRAR,
GRAPHIC ERA
DEEMED TO BE
UNIVERSITY**
Address of
Applicant :566/6, Bell
Road, Clement Town,
Dehradun 248002,
Uttarakhand, India
Uttarakhand India
(72)Name of Inventor :
**1)Vaibhav Aggarwal
2)Vaibhav Gupta
3)Devesh Pratap
Singh
4)Bhasker Pant
5)D.R. Gangodkar**

(57) Abstract :

The present invention relate to the field of a system for assessment of a psychological condition of a patient. More particularly, the invention pertains to real time assessment of a psychological condition relating to cataract detection system and method thereof. The system described by the invention comprising an electronic device comprises a camera , an operating system , a processor and a memory wherein the a coded program application used to initiate the camera for capturing image, analyzing face and eye image through a processing tool with the algorithms of machine learning to obtained the results.

No. of Pages : 18 No. of Claims : 9

(12) PATENT APPLICATION PUBLICATION

(21) Application
No.201811039744 A

(19) INDIA

(22) Date of filing of Application :22/10/2018

(43) Publication Date :
20/12/2019

(54) Title of the invention : AN INTELLIGENT ALCOHOL SENSING AND ALERTING/NOTIFYING SYSTEM AND METHOD THEREOF

(51)
International :G08B0021220000,G01S0005000000,G08G0001096200,G08B0025100000,G01N0033000000
classification
(31) Priority
Document :NA
No
(32) Priority :NA
Date
(33) Name
of priority :NA
country
(86)
International
Application :NA
No :NA
Filing
Date
(87)
International : NA
Publication
No
(61) Patent
of Addition
to
Application :NA
Number :NA
Filing
Date
(62)
Divisional to
Application :NA
Number :NA
Filing
Date

(71)**Name of Applicant**
:
**1)THE
REGISTRAR,
GRAPHIC ERA
DEEMED TO BE
UNIVERSITY**
Address of
Applicant :566/6, Bell
Road, Clement Town,
Dehradun 248002,
Uttarakhand, India
Uttarakhand India
(72)**Name of Inventor :**
**1)Vaibhav Aggarwal
2)Vaibhav Gupta
3)Vivasvan Manasvi
Vashisth
4)Devesh Pratap
Singh
5)Bhasker Pant**

(57) Abstract :

The present invention relate to an intelligent alcohol sensing system and method thereof for driver/ person of the vehicle and automatically generate alert services to the nearby locals and traffic controlling office / police station to take the required action immediately. The system for alcohol sensing embedded inside the vehicle comprising a sensor module to sense the alcohol content above the pre set threshold limit, a microcontroller module to receive, process and generate the output signal, a relay system to control the movement of the vehicle and a communication module to transmitting the signal to the nearest traffic light office / police station and notifying the driver's family on sensing the alcohol content above the pre-set threshold limit.

No. of Pages : 17 No. of Claims : 8

(12) PATENT APPLICATION PUBLICATION

(21) Application
No.201811039745 A

(19) INDIA

(22) Date of filing of Application :22/10/2018

(43) Publication Date :
20/12/2019

(54) Title of the invention : SMART SHOE FOR NAVIGATION OF BLIND PEOPLE

(51)
International :A61H0003060000,G01S0015930000,G06F0001160000,A61B0005103000,G08G0001160000
classification
(31) Priority
Document :NA
No
(32) Priority
Date :NA
(33) Name
of priority :NA
country
(86)
International
Application :NA
No :NA
Filing
Date
(87)
International
Publication : NA
No
(61) Patent
of Addition
to
Application :NA
Number :NA
Filing
Date
(62)
Divisional to
Application :NA
Number :NA
Filing
Date

(71)**Name of Applicant**
:
**1)THE REGISTRAR,
GRAPHIC ERA
DEEMED TO BE
UNIVERSITY**
Address of Applicant
:566/6, Bell Road,
Clement Town,
Dehradun 248002,
Uttarakhand, India
Uttarakhand India
(72)**Name of Inventor :**
**1)Vaibhav Aggarwal
2)Vaibhav Gupta
3)Devesh Pratap
Singh
4)Bhasker Pant**

(57) Abstract :

The present disclosure discloses a smart navigation system for blind people and method thereof. More specifically, the system embedded inside the footwear and comprising a pressure sensor to sense the force applied by the user's , a detector comprising an ultrasonic sensor to detect different kinds of object around the surrounding, a chip comprising a processing module and connected with the sensor and the detector to facilitating accurately process the signal obtained from the said sensor and detector and provide an optimum and accurate output and a vibratory means to interact with the user to navigate.

No. of Pages : 14 No. of Claims : 8

(12) PATENT APPLICATION PUBLICATION

(21) Application
No.201811040645 A

(19) INDIA

(22) Date of filing of Application :29/10/2018

(43) Publication Date :
20/12/2019

(54) Title of the invention : METHOD AND SYSTEM FOR REAL-TIME ACTIVITIES OF VEHICLES

(51)
International :H04L0029080000,H04W0004400000,H04W0084180000,B60R0016023000,G16H0010600000
classification
(31) Priority
Document :NA
No
(32) Priority :NA
Date
(33) Name
of priority :NA
country
(86)
International
Application :NA
No :NA
Filing
Date
(87)
International : NA
Publication
No
(61) Patent
of Addition
to
Application :NA
Number :NA
Filing
Date
(62)
Divisional to
Application :NA
Number :NA
Filing
Date

(71)**Name of Applicant :**
1)THE REGISTRAR, GRAPHIC ERA DEEMED TO BE UNIVERSITY
Address of Applicant :566/6, Bell Road, Clement Town, Dehradun 248002, Uttarakhand, India
Uttarakhand India
(72)**Name of Inventor :**
1)Dr. Sachin Sharma
2)Prof. (Dr.) Kamal Kumar Ghanshala

(57) Abstract :

The present invention relates to a Cloud-Based Vehicular Network Architecture. More particularly, the invention provides the system and method for Cloud-Based Cognitive Radio Ad-hoc Vehicular Network Architecture for Smart City services used by the user through computer assisted devices or smart devices. The system a computer implemented system comprising processor and programmed application for real time collection of data/information for services from various sources, a cloud server to store and share collected data, a data transfer unit embedded inside the vehicle which comprising a vehicle's on-board units (OBU) share the collect the data from the vehicle's comprising pluralities of sensors and upload the data to the Cloud server and Communication infrastructure comprising vehicle to vehicle and vehicle to internet communication which configured to share information between vehicle and cloud server.

No. of Pages : 23 No. of Claims : 10

(12) PATENT APPLICATION PUBLICATION

(21) Application
No.201811040646 A

(19) INDIA

(22) Date of filing of Application :29/10/2018

(43) Publication Date :
20/12/2019

(54) Title of the invention : A SECURITY SYSTEM FOR INTERNET OF VEHICLES (IOV) AND METHOD THEREOF

(51)
International :H04L0029080000,H04W0004440000,H04N0021222000,H04W0084000000,G08G0001096700
classification

(31) Priority
Document :NA
No

(32) Priority
Date :NA

(33) Name
of priority :NA
country

(86)
International
Application :NA
No :NA

Filing
Date

(87)
International
Publication : NA
No

(61) Patent
of Addition
to
Application :NA
Number :NA

Filing
Date

(62)
Divisional to
Application :NA
Number :NA

Filing
Date

(71)**Name of Applicant :**
1)THE REGISTRAR, GRAPHIC ERA DEEMED TO BE UNIVERSITY
Address of Applicant :566/6, Bell Road, Clement Town, Dehradun 248002, Uttarakhand, India
Uttarakhand India

(72)**Name of Inventor :**
1)Dr. Sachin Sharma
2)Prof. (Dr.) Kamal Kumar Ghanshala

(57) Abstract :

The present invention relates to a smart secure system and method for Internet of Vehicles (IoV). In particular, the invention provides internet-of-vehicle (IoV) security system for smart spectrum utilization (SSU) in connected vehicles controlled by advanced distributed systems.

No. of Pages : 24 No. of Claims : 9

(12) PATENT APPLICATION PUBLICATION

(21) Application
No.201811047924 A

(19) INDIA

(22) Date of filing of Application :18/12/2018

(43) Publication Date :
20/12/2019

(54) Title of the invention : A MULTICOMPONENT HIGH ENTROPY ALLOY COMPOSITE AND A PREPARATION METHOD THEREOF

(51)
International :B22F0003105000,C04B0035580000,B22F0001000000,B22F0009040000,C04B0035645000
classification

(31) Priority
Document :NA
No

(32) Priority :NA
Date

(33) Name
of priority :NA
country

(86)
International
Application :PCT//
No :01/01/1900

Filing
Date
(87)
International : NA
Publication
No

(61) Patent
of Addition
to
Application :NA
Number :NA
Filing
Date

(62)
Divisional to
Application :NA
Number :NA
Filing
Date

(71)Name of Applicant :
**1)Indian Institute of
Technology Kanpur**

Address of Applicant
:Dean, Research &
Development, Room
Number 151, Faculty
Building, IIT Kanpur,
Kanpur, Uttar Pradesh,
India Uttar Pradesh India

(72)Name of Inventor :
**1)Surekha Yadav
2)Arvind Kumar
3)Krishanu Biswas**

(57) Abstract :

A MULTICOMPONENT HIGH ENTROPY ALLOY COMPOSITE AND A PREPARATION METHOD THEREOF ABSTRACT A method for preparation of multicomponent high entropy alloy is disclosed. The method includes synthesis of (Al₂₀Cr₂₀Fe₂₀Mn₂₀V₂₀) alloy using a mechanical milling technique to obtain a single-phase alloy. The method also includes milling bismuth (Bi) and titanium diboride (TiB₂) powder for 3 hours using a cryo-milling technique, at liquid nitrogen temperature, to obtain nanocrystalline bismuth (Bi) and titanium diboride (TiB₂) powder. The method further includes mixing single-phase (Al₂₀Cr₂₀Fe₂₀Mn₂₀V₂₀) alloy with nanocrystalline bismuth (Bi) and titanium diboride (TiB₂) powder using ball milling at room temperature for 10 hours to obtain a homogeneous mixture. The method further includes sintering the homogenous mixture using a spark plasma sintering technique to obtain the high entropy alloy composite. The high entropy alloy composite may be used to fabricate gears having high hardness with excellent wear resistance. FIG. 2

No. of Pages : 26 No. of Claims : 7

(12) PATENT APPLICATION PUBLICATION

(21) Application
No.201911031043 A

(19) INDIA

(22) Date of filing of Application :01/08/2019

(43) Publication Date :
20/12/2019

(54) Title of the invention : HYBRID QUANTUM ASYNCHRONOUS PROCESSOR(HQAP) WITH QCEP

(51)
International :G06N0010000000,G06N0003063000,B82Y0010000000,G06N0020000000,G06F000950000
classification
(31) Priority
Document :NA
No
(32) Priority :NA
Date
(33) Name
of priority :NA
country
(86)
International
Application :NA
No :NA
Filing
Date
(87)
International : NA
Publication
No
(61) Patent
of Addition
to
Application :NA
Number :NA
Filing
Date
(62)
Divisional to
Application :NA
Number :NA
Filing
Date

(71)Name of Applicant
:
1)PARTH BIR
Address of Applicant
:BA/156/B, BA
BLOCK, JANAKPURI,
NEW DELHI, INDIA
Delhi India
2)S.PRATAP SINGH
3)BRIJESH KUMAR
SINGH
4)LAKSHMANAN.
M
5)NISHA KUMARI
(72)Name of Inventor :
1)PARTH BIR
2)S.PRATAP SINGH
3)BRIJESH KUMAR
SINGH
4)LAKSHMANAN.
M
5)NISHA KUMARI

(57) Abstract :

Hybrid Quantum Asynchronous Processor (HQAP) with QCEP is the processor cores round the world are facing the dilemma posed by conventional computational methods in terms of computational power, size, power consumption and many more. While the demand for higher computation power rises constantly, the industry is unable to keep up, and has chosen to supplement it with sticking to conventional methods by introducing accelerators like GPU and FPGA. Even afterwards, the core problems remain unsolved, but definitely more tangled due to the complexities and glitches posed by the additional un-necessities. Also, on a global scale questions posed by entities like cancer, diabetes, making of the universe etc. can be resolved by solutions from quantum computation. The proposed invention uses concepts of Quantum Mechanics, Quantum Field Theory, Asynchronous circuits, Hyper Threading technology and Machine Learning to design the Hybrid Quantum Asynchronous Processor (fig 8) (HQAP) with Quantum Computation Enabled Pipelining (QCEP) which can function as a pure Quantum Processor (fig 2), artificial Quantum processor, Quantum accelerator or even as a conventional processor.

No. of Pages : 41 No. of Claims : 35

(12) PATENT APPLICATION PUBLICATION

(21) Application
No.201911033876 A

(19) INDIA

(22) Date of filing of Application :22/08/2019

(43) Publication Date :
20/12/2019

(54) Title of the invention : RED BRICK AND PROCESS FOR PREPARATION THEREOF

(51)
International :C04B0028040000,C04B0018040000,C04B0028020000,C04B0033132000,C04B0033135000
classification
(31) Priority
Document :NA
No
(32) Priority :NA
Date
(33) Name
of priority :NA
country
(86)
International
Application :NA
No :NA
Filing
Date
(87)
International : NA
Publication
No
(61) Patent
of Addition
to
Application :NA
Number :NA
Filing
Date
(62)
Divisional to
Application :NA
Number :NA
Filing
Date

(71)**Name of Applicant :**
**1)HINDALCO
INDUSTRIES
LIMITED**
Address of Applicant
:P/O-Renukoot,
Sonbhadra District, Uttar
Pradesh 231217, India
Uttar Pradesh India
(72)**Name of Inventor :**
**1)JAJOO, Satish
Narain**
**2)SAINI, Rajesh
Kumar**
**3)PANDEY, Anil
Kumar**

(57) Abstract :

The present disclosure relates to a red brick comprising: 20-50 wt% of red mud; 10-20 wt% of bottom ash; 10-30 wt% of natural sand; 15-30 wt% of fly ash; and 4-15 wt% of Portland cement. The present disclosure also relates to a process for preparing a red brick comprising: mixing 20-50 wt% of red mud, 10-20 wt% of bottom ash, 10-30 wt% of natural sand to form a first mixture, adding 15-30 wt% of fly ash and 4-15 wt% of Portland cement to the first mixture to form a second mixture, rolling the second mixture in a pan mixer having roller and scraper to produce a final mixture, molding the final mixture in a brick press to provide a pressed red brick, and stacking the pressed red brick in yards to form a red brick.

No. of Pages : 15 No. of Claims : 10

(12) PATENT APPLICATION PUBLICATION

(21) Application
No.201911038186 A

(19) INDIA

(22) Date of filing of Application :22/09/2019

(43) Publication Date :
20/12/2019

(54) Title of the invention : LTCC (LOW TEMPERATURE CO-FIRED CERAMIC) RESONATING MATERIAL FOR THE DESIGN OF ELECTROMAGNETIC OSCILLATOR AND METHOD OF PRODUCTION THEREOF.

(51)
International :H05K0001030000,C04B0035626000,C04B0035443000,C04B0035495000,C03C0008140000
classification

(31) Priority
Document :NA
No

(32) Priority :NA
Date

(33) Name
of priority :NA
country

(86)
International
Application :NA
No :NA

Filing
Date
(87)

International : NA
Publication
No

(61) Patent
of Addition
to
Application :NA
Number :NA

Filing
Date
(62)

Divisional to
Application :NA
Number :NA

Filing
Date

(71)Name of Applicant
:

1)Dr. Preeti Kumari
Address of Applicant
:D/O- Dr. C S Prasad,
Mohalla Panjabiyan,
Sector 6, Subash Road,
Khurja Uttar Pradesh
India

(72)Name of Inventor :
1)Dr. Preeti Kumari

(57) Abstract :

The present invention emphasizes on development of glass free ceramic system to achieve good microwave dielectric properties with low loss. LiMg(i-i.5x)AlxP04 (LMAP) (x = 0.00 - 0.08) ceramic system was prepared through solid state synthesis route at different sintering temperatures (800 - 925 °C). A small addition of Al2O3 (x = 0.02) in LMAP ceramics lowers the sintering temperature by more than 100 °C with good relative density of 94.13 %. This ceramic is utilised as component of resonating material for the design of oscillator. One embodiment of the present invention is to provide a ceramic dielectric material that has a relatively low to medium dielectric constant and a low dielectric loss. Another embodiment of the present invention find its application as substrates in integrated circuits, thermally stable resonators, filters, oscillators, phase shifters, isolators, circulators and antennas in microwave and millimeter wave communication and radar systems. Another embodiment of the present invention is to select a ceramic having low dielectric constant, low loss tangent and good thermal stability and method of production thereof.

No. of Pages : 13 No. of Claims : 9

(12) PATENT APPLICATION PUBLICATION

(21) Application No.201911040583 A

(19) INDIA

(22) Date of filing of Application :07/10/2019

(43) Publication Date : 20/12/2019

(54) Title of the invention : A PHARMACEUTICAL COMPOSITION FOR THE PREVENTION OR THE TREATMENT OF OPHTHALMIC CONDITIONS

(51) International classification :A61P27/02
(31) Priority Document No :NA
(32) Priority Date :NA
(33) Name of priority country :NA
(86) International Application No :NA
Filing Date :NA
(87) International Publication No : NA
(61) Patent of Addition to Application Number :NA
Filing Date :NA
(62) Divisional to Application Number :NA
Filing Date :NA

(71)Name of Applicant :
1)Dr. Mahender Singh Basu
Address of Applicant :23-B, Ekta Nagar, Stadium Road,
Bareilly, Uttar Pradesh Uttar Pradesh India
(72)Name of Inventor :
1)Dr. Mahender Singh Basu

(57) Abstract :

The present invention relates to a novel pharmaceutical composition for the prevention or the treatment of ophthalmic conditions such as cataract, myopia, hypermetropia, glaucoma, color blindness, diabetic retinopathy, macular degeneration, retinitis pigmentosa and the pharmaceutical composition in a clear aqueous solution form comprising extracts of Leptadenia reticulata, Embelica officinalis, Butea monosperma, Santalum album, Achyranthus asparagus, Foeniculum vulgare, Borrhavia diffusa, Eclipta prostrata, Terminalia arjuna, Menthapiperata and preservatives.

No. of Pages : 20 No. of Claims : 7

(12) PATENT APPLICATION PUBLICATION

(21) Application
No.201911044970 A

(19) INDIA

(22) Date of filing of Application :05/11/2019

(43) Publication Date :
20/12/2019

(54) Title of the invention : FULLY AUTOMATED ELECTROSTATIC PAGE TURNING TECHNIQUE & DEVICE FOR DOCUMENT SCANNING

(51)
International :G06F0003041000,G01N0033340000,B60K0037060000,G01J0005080000,B33Y0010000000
classification
(31) Priority
Document :NA
No
(32) Priority :NA
Date
(33) Name
of priority :NA
country
(86)
International
Application :NA
No :NA
Filing
Date
(87)
International : NA
Publication
No
(61) Patent
of Addition
to
Application :NA
Number :NA
Filing
Date
(62)
Divisional to
Application :NA
Number :NA
Filing
Date

(71)**Name of Applicant :**
1)Utkarsh Kunwar
Address of Applicant
:School of Engineering,
Indian Institute of
Technology Mandi,
Kamand Campus
175005, Himachal
Pradesh, India Himachal
Pradesh India
**2)Parinaya
Chaturvedi**
3)Dr. Hitesh Shrimali
(72)**Name of Inventor :**
1)Utkarsh Kunwar
**2)Parinaya
Chaturvedi**
3)Dr. Hitesh Shrimali

(57) Abstract :

A fully automated electrostatic page turning technique & device for document scanning, the said data output device comprising of an input surface adapted to be locally exposed to electromagnetic radiation, a sensor means disposed above or below the input surface for detecting the status, characteristics, and properties of the material on the input surface and for) outputting an output signal representing said features, and an evaluating means for evaluating the output signal of the sensor means, and iterating over the process by changing the material by means of an external force, either physical, electrostatic, or electromagnetic, and a discharging unit to remove the residual charge buildup on the document.

No. of Pages : 14 No. of Claims : 9

(12) PATENT APPLICATION PUBLICATION

(21) Application
No.201911047902 A

(19) INDIA

(22) Date of filing of Application :22/11/2019

(43) Publication Date :
20/12/2019

(54) Title of the invention : PAPAYA WINE BEVERAGE COMPOSITION AND A METHOD OF PREPARATION THEREOF

(51)
International :A61K0036185000,A23L0033105000,G01N0021356300,A23L0019000000,C12G0003020000
classification
(31) Priority
Document :NA
No
(32) Priority :NA
Date
(33) Name
of priority :NA
country
(86)
International
Application :NA
No :NA
Filing
Date
(87)
International
Publication : NA
No
(61) Patent
of Addition
to
Application :NA
Number :NA
Filing
Date
(62)
Divisional to
Application :NA
Number :NA
Filing
Date

(71)**Name of Applicant**
:
**1)Chandigarh Group
of Colleges**
Address of
Applicant :Landran
Kharar Banur Highway,
Sector 112, Sahibzada
Ajit Singh Nagar,
Mohali, Punjab-140307,
India. Punjab India
(72)**Name of Inventor :**
1)Dr. Sonica Sondhi
2)Palki Sahib Kaur
3)Pratibha Dwivedi

(57) Abstract :

The present invention relates to a papaya wine beverage composition obtained from leaves, fruit peels and seeds of Carica papaya and a method of preparation thereof. The method of preparation of the composition comprises of the steps of: a) drying the leaves, ripe fruit peels and seeds of Carica papaya in sunlight and then separately ground to obtain a powdered material, b) passing the powdered material through a sieve to obtain a uniform powder sample, c) mixing the powder sample with a solvent solution containing a sugar, calcium sulphate, acetate buffer of pH 3-4 and water to obtain a mixture, and d) adding Saccharomyces cerevisiae culture to the mixture followed by fermentation for 3-5 days at a temperature from 30-40°C to obtain the papaya wine beverage composition.

No. of Pages : 11 No. of Claims : 7

(12) PATENT APPLICATION PUBLICATION

(21) Application
No.201911047997 A

(19) INDIA

(22) Date of filing of Application :25/11/2019

(43) Publication Date :
20/12/2019

(54) Title of the invention : MUSHROOOM BISCUITS AND PREPARATION THEREOF

(51)
International :H01J0049140000,A21D0002340000,A61K0036580000,A21D0002020000,A21D0008020000
classification
(31) Priority
Document :NA
No
(32) Priority :NA
Date
(33) Name
of priority :NA
country
(86)
International
Application :NA
No :NA
Filing
Date
(87)
International
Publication : NA
No
(61) Patent
of Addition
to
Application :NA
Number :NA
Filing
Date
(62)
Divisional to
Application :NA
Number :NA
Filing
Date

(71)Name of Applicant
:
**1)Dr. RAJENDRA
PRASAD CENTRAL
AGRICULTURAL
UNIVERSITY**
Address of Applicant
:PUSA, SAMASTIPUR,
BIHAR, INDIA Delhi
India
(72)Name of Inventor :
1)Dr. DAYARAM

(57) Abstract :

The invention relates to a mushroom biscuit comprising; mushroom powder; refined flour; leavening agent; sugar; milk; flavouring agent; desi ghee and method of preparation thereof.

No. of Pages : 13 No. of Claims : 8

(12) PATENT APPLICATION PUBLICATION

(21) Application
No.201911048352 A

(19) INDIA

(22) Date of filing of Application :26/11/2019

(43) Publication Date :
20/12/2019

(54) Title of the invention : THERMAL MANAGEMENT SYSTEM FOR A BATTERY PACK AND METHOD THEREOF

(51)
International :H01M0010613000,H01M0002100000,H01M0010625000,H01M0010658000,F25B0021020000
classification
(31) Priority
Document :NA
No
(32) Priority :NA
Date
(33) Name
of priority :NA
country
(86)
International
Application :NA
No :NA
Filing
Date
(87)
International : NA
Publication
No
(61) Patent
of Addition
to
Application :NA
Number :NA
Filing
Date
(62)
Divisional to
Application :NA
Number :NA
Filing
Date

(71)Name of
Applicant :
**1)Lithion Power
Private Limited**
Address of
Applicant :413, D-
Mall, Sector-10,
Rohini, Delhi- 110085,
India. Delhi India
(72)Name of Inventor
:
**1)BHARDWAJ,
Vasu**
2)GUPTA, Piyush

(57) Abstract :

Present disclosure relate to system and method for maintaining operating temperature of batteries during their operation, within an optimum operating range. The proposed system and method work is based on imparting the properties and use of a PCM along with peltier devices. The system includes a support structure having compartments to accommodate the battery pack that comprises one or more battery cells; thermal bags configured with the support structure to store phase change materials, the thermal bags configured such that an outer surface of the thermal bags are thermally coupled with the battery pack and enabling heat transfer between the phase change materials and the battery cells of the battery pack to maintain temperature of the battery cells within a predefined temperature range; and one or more thermoelectric heat pumps configured for fitment with the support structure to keep the one or more phase change materials into their original state.

No. of Pages : 25 No. of Claims : 10

(12) PATENT APPLICATION PUBLICATION

(21) Application
No.201911048519 A

(19) INDIA

(22) Date of filing of Application :27/11/2019

(43) Publication Date :
20/12/2019

(54) Title of the invention : WASTE MANAGEMENT THROUGH SMART ECO BIN

(51)
International :H04L0029080000,B65F0001140000,B65F0001160000,G09F0015000000,B30B0009300000
classification
(31) Priority
Document :NA
No
(32) Priority :NA
Date
(33) Name
of priority :NA
country
(86)
International
Application :NA
No :NA
Filing
Date
(87)
International
Publication : NA
No
(61) Patent
of Addition
to
Application :NA
Number :NA
Filing
Date
(62)
Divisional to
Application :NA
Number :NA
Filing
Date

(71)**Name of Applicant :**
**1)Lovely Professional
University**
Address of Applicant
:Lovely Professional
University Jalandhar-
Delhi G.T. Road,
Phagwara, Punjab-144
411, India Punjab India
(72)**Name of Inventor :**
**1)CHOUDHURY,
Ruhul Amin**
2)SINGH, Mandeep
**3)RAJPUT, Anant
Kumar**
4)JANGRA, Ashish
5)KOTNI, Manish

(57) Abstract :

Disclosed is a smart ECO bin for waste management which consists of compressing plate to compress and waste in the container and make space for more garbage, and every ECO bin assigns unique ID through which information regarding level of waste monitors by waste management server. The present invention provides removable garbage container in the bin and makes convenient for workers to dispose as well as automatic cleaning roller is attached to front side for cleaning. The present invention further facilitates LED poster display area on three sides of bin for displaying posters.

No. of Pages : 17 No. of Claims : 8

(12) PATENT APPLICATION PUBLICATION

(21) Application
No.201911048520 A

(19) INDIA

(22) Date of filing of Application :27/11/2019

(43) Publication Date
: 20/12/2019

(54) Title of the invention : COMPACT LOW COST IOT ENABLED WEATHER STATION FOR AGROMETEOROLOGY

<p>(51) International :G01W0001100000,G01W0001020000,G01W0001000000,H04W0074080000,G01S0013950000 classification (31) Priority Document :NA No (32) Priority :NA Date (33) Name of priority :NA country (86) International Application :NA No :NA Filing Date (87) International Publication : NA No (61) Patent of Addition to Application :NA Number :NA Filing Date (62) Divisional to Application :NA Number :NA Filing Date</p>	<p>(71)Name of Applicant : 1)Lovely Professional University Address of Applicant :Lovely Professional University Jalandhar-Delhi G.T. Road, Phagwara, Punjab-144 411, India Punjab India (72)Name of Inventor : 1)SINGH, Dushyant Kumar 2)JERATH, Himani 3)RAJA, P</p>
--	--

(57) Abstract :

Disclosed is an IoT enabled weather station for measuring the atmospheric related parameters through weather sensors. The present invention improves power efficiency as no display is connected with system and user monitors data through IoT cloud server on mobile/desktop/laptop using application. The present invention provides a cost effective solution to weather station for uploading atmospheric parameters and it is easy to install. The present invention further facilitates downloading of past atmospheric parameters information in excel worksheet for further analysis.

No. of Pages : 14 No. of Claims : 8

(12) PATENT APPLICATION PUBLICATION

(21) Application
No.201911048594 A

(19) INDIA

(22) Date of filing of Application :27/11/2019

(43) Publication Date :
20/12/2019

(54) Title of the invention : GRAPHENE MIXED NANO-FLUID AS POTENTIAL LUBRICANT/COOLANT FOR TURNING PURPOSES

(51)
International :B23Q0011100000,G05B0019406500,B23Q0011000000,B23P0025000000,B23B0027000000
classification
(31) Priority
Document :NA
No
(32) Priority :NA
Date
(33) Name
of priority :NA
country
(86)
International
Application :NA
No :NA
Filing
Date
(87)
International : NA
Publication
No
(61) Patent
of Addition
to
Application :NA
Number :NA
Filing
Date
(62)
Divisional to
Application :NA
Number :NA
Filing
Date

(71)**Name of Applicant**
:
1)RUPINDER SINGH
Address of Applicant
:Department of
Mechanical Engineering,
University school of
Engineering &
Technology, Rayat Bahra
University, Mohali,
Punjab, India Punjab
India
(72)**Name of Inventor** :
1)Rupinder Singh
2)J.S. Dureja
3)Manu Dogra
4)Munish Kumar
Gupta
5)Mozammel Mia

(57) Abstract :

An advanced graphene enriched nano-fluids and lubricant/coolant for textured tool has been introduced for the turning purposes. In turning, the force exerted by single point cutting tool for deformation of the workpiece material is transformed into heat. The greater part of this heat is taken away by chips, which partly goes to the material itself and some carried away by a cutting tool. This dissipated heat, results in deterioration of both machined workpiece surface quality and tool life. Graphene enhances maximum tool life, lowers cutting forces, reduces minimum cutting temperature when used with nano particle based minimum quantity lubrication (NMQL), minimum quantity lubrication (MQL) and textured tools for turning. The tool life under NMQL is improved by 178% to 190%, main cutting forces are minimized by 36% to 40%, and cutting temperature is reduced by 31% to 42 % compared to dry conditions at various cutting speeds. However, graphene enriched NMQL shows improved performances mainly due to higher thermal conductivity of MQL fluid mixture and shearing action imparted by graphene on different contact surfaces of tool. Further, the phenomena of improved thermal conductivity and shearing action imparted by graphene has been demonstrated by using transient hot-wire/SEM/Raman spectroscopy, etc. Figure 1, Figure 2, Figure 3, Figure 4, Figure 5, Figure 6, Figure 7, Figure 8, Figure 9, Figure 10 Table 1, Table 2, Table 3, Table 4, Table 5, Table 6, Table 7,Table 8

No. of Pages : 36 No. of Claims : 8

(12) PATENT APPLICATION PUBLICATION

(21) Application
No.201911048755 A

(19) INDIA

(22) Date of filing of Application :28/11/2019

(43) Publication Date :
20/12/2019

(54) Title of the invention : LOW-POWER LOW-COST AIR-QUALITY MONITORING, PREDICTING, AND WARNING SYSTEM

(51)
International :G06N0020000000,G08B0021100000,G08B0021160000,G01W0001020000,G01D0021020000
classification
(31) Priority
Document :NA
No
(32) Priority :NA
Date
(33) Name
of priority :NA
country
(86)
International
Application :PCT//
No :01/01/1900
Filing
Date
(87)
International : NA
Publication
No
(61) Patent
of Addition
to
Application :NA
Number :NA
Filing
Date
(62)
Divisional to
Application :NA
Number :NA
Filing
Date

(71)**Name of Applicant :**
1)Varun Dutt
Address of Applicant :Applied Cognitive Science Lab, Indian Institute of Technology (IIT) Mandi, Kamand Campus, VPO Kamand, District Mandi, Himachal Pradesh 175005 Himachal Pradesh India
2)Pratik Chaturvedi
3)Tushar Saini
4)Praveen Kumar
5)Ankush Pathania
6)D C Rana
7)Suresh C Attri
(72)**Name of Inventor :**
1)Varun Dutt
2)Pratik Chaturvedi
3)Tushar Saini
4)Praveen Kumar
5)Ankush Pathania
6)D C Rana
7)Suresh C Attri

(57) Abstract :

Present invention discloses an IoT-based air-quality monitoring, predicting, and warning system comprising of a sensing module that senses the real-time pollution using MEMS-based sensors, a machine-learning (ML) module that predicts the forthcoming pollution levels, and a warning system that warns via SMSs if certain pollutants breach predefined thresholds. The system monitors seven major pollutants, namely, PM1.0, PM2.5, PM10, Carbon Monoxide, Nitrogen Dioxide, Ozone, and Sulfur Dioxide, and also measures other important parameters such as temperature, pressure, humidity, wind speed, and wind direction. Moreover, said system is power-efficient and can sustain itself with solar power and battery, and thus can be easily deployed in remote rural areas, where grid-connected power supply is a problem.

No. of Pages : 16 No. of Claims : 10

(12) PATENT APPLICATION PUBLICATION

(21) Application
No.201911048892 A

(19) INDIA

(22) Date of filing of Application :28/11/2019

(43) Publication Date :
20/12/2019

(54) Title of the invention : A PROCESS OF LEAN AND VALUE ENGINEERING

(51)
International :G06Q0010060000,G06F0017500000,C12N0009800000,C11D0003200000,F01D0005140000
classification
(31) Priority
Document :NA
No
(32) Priority :NA
Date
(33) Name
of priority :NA
country
(86)
International
Application :NA
No :NA
Filing
Date
(87)
International
Publication : NA
No
(61) Patent
of Addition
to
Application :NA
Number :NA
Filing
Date
(62)
Divisional to
Application :NA
Number :NA
Filing
Date

(71)**Name of Applicant**
:
**1)Lovely Professional
University**
Address of Applicant
:Lovely Professional
University Jalandhar-
Delhi G.T. Road,
Phagwara, Punjab-144
411, India Punjab India
(72)**Name of Inventor :**
**1)SINGH, Vijay
Kumar**
2)RATHI, Rajeev
**3)PRAKASH,
Chander**

(57) Abstract :

The present invention discloses a process of lean and value engineering. The process reduces waste elements. The process also reduces cost and improves functionality. The process consist of lean tool and value engineering.

No. of Pages : 10 No. of Claims : 4

(12) PATENT APPLICATION PUBLICATION

(21) Application
No.201911048893 A

(19) INDIA

(22) Date of filing of Application :28/11/2019

(43) Publication Date :
20/12/2019

(54) Title of the invention : A NOVEL CLOCK SYSTEM FOR GAMES

(51)
International :A63F0003000000,G07F0017320000,H01M0010052500,A63F0003020000,G07C0001280000
classification
(31) Priority
Document :NA
No
(32) Priority
Date :NA
(33) Name
of priority :NA
country
(86)
International
Application :NA
No :NA
Filing
Date
(87)
International
Publication : NA
No
(61) Patent
of Addition
to
Application :NA
Number :NA
Filing
Date
(62)
Divisional to
Application :NA
Number :NA
Filing
Date

(71)**Name of Applicant**
:
**1)Lovely Professional
University**
Address of Applicant
:Lovely Professional
University Jalandhar-
Delhi G.T. Road,
Phagwara, Punjab-144
411, India Punjab India
(72)**Name of Inventor :**
1)SINGH, Manpreet
2)GULATI, Piyush
**3)SINGH, Jaiinder
Preet**
4)SINGH, Rajesh
5)SINGH, Satnam

(57) Abstract :

The present invention discloses a novel clock system for games. The clock system of games consists of a chess board, pieces, a reader, a controller, two counters and a Li-ion battery. Chess players need not to tick the chess clock and can concentrate more on their game. The system is advantageous in rapid chess tournaments where time counting can be more accurately encountered.

No. of Pages : 15 No. of Claims : 7

(12) PATENT APPLICATION PUBLICATION

(21) Application
No.201911048894 A

(19) INDIA

(22) Date of filing of Application :28/11/2019

(43) Publication Date :
20/12/2019

(54) Title of the invention : A NOVEL WATER TREATMENT SYSTEM OF FLOATING CONCRETE

(51)
International :C02F0003320000,G06T0007000000,C02F0001500000,C02F0001780000,C08K0003080000
classification

(31) Priority
Document :NA
No

(32) Priority
Date :NA

(33) Name
of priority :NA
country

(86)
International
Application :NA
No :NA

Filing
Date

(87)
International
Publication : NA
No

(61) Patent
of Addition
to
Application :NA
Number :NA

Filing
Date

(62)
Divisional to
Application :NA
Number :NA

Filing
Date

(71)Name of Applicant :
**1)Lovely Professional
University**

Address of Applicant
:Lovely Professional
University Jalandhar-
Delhi G.T. Road,
Phagwara, Punjab-144
411, India Punjab India

(72)Name of Inventor :
**1)SHARMA, Ashutosh
2)ANEJA, Sakshi
3)SHARMA, Neeta**

Raj

(57) Abstract :

The present invention discloses a system of floating concrete more preferably a water treating system of floating concrete. The system consists of a floating component, vegetation grown on the floating component, monitoring components and solar panels. The system increases the aesthetic value of waste water bodies. The system is low cost and sustainable.

No. of Pages : 13 No. of Claims : 6

(12) PATENT APPLICATION PUBLICATION

(21) Application
No.201911048895 A

(19) INDIA

(22) Date of filing of Application :28/11/2019

(43) Publication Date :
20/12/2019

(54) Title of the invention : AN INTEGRATED DEVICE FOR ARTS-CRAFT

(51)
International :A61K0009000000,A61N0001080000,H04W0004800000,H04M0001020000,A61K0031000000
classification

(31) Priority
Document :NA
No

(32) Priority
Date :NA

(33) Name
of priority :NA
country

(86)
International
Application :NA
No :NA

Filing
Date

(87)
International
Publication : NA
No

(61) Patent
of Addition
to
Application :NA
Number :NA

Filing
Date

(62)
Divisional to
Application :NA
Number :NA

Filing
Date

(71)**Name of Applicant :**
1)Lovely Professional University
Address of Applicant :Lovely Professional University Jalandhar-Delhi G.T. Road, Phagwara, Punjab-144 411, India Punjab India

(72)**Name of Inventor :**
1)SINGH, Jaskaran
2)SHARMA, Neeta Raj
3)SINGH, Rajesh
4)GEHLOT, Anita
5)KUMAR, Prashant

(57) Abstract :

The present invention discloses a smart device for art-craft. The device is easy to operate. The device is useful for high resolution drawing for making fine dimension. The device also acts as scissor.

No. of Pages : 13 No. of Claims : 5

(12) PATENT APPLICATION PUBLICATION

(21) Application
No.201911048896 A

(19) INDIA

(22) Date of filing of Application :28/11/2019

(43) Publication Date :
20/12/2019

(54) Title of the invention : A NOVEL AUTOMATIC STIRRING SYSTEM FOR UTENSIL

(51)
International :A47J0036320000,A47J0027000000,A47J0037100000,F17C0001040000,G06T0007120000
classification

(31) Priority
Document :NA
No

(32) Priority
Date :NA

(33) Name
of priority :NA
country

(86)
International
Application :NA
No :NA

Filing
Date

(87)
International
Publication : NA
No

(61) Patent
of Addition
to
Application :NA
Number :NA

Filing
Date

(62)
Divisional to
Application :NA
Number :NA

Filing
Date

(71)Name of Applicant :
**1)Lovely Professional
University**
Address of Applicant
:Lovely Professional
University Jalandhar-Delhi
G.T. Road, Phagwara,
Punjab-144 411, India
Punjab India

(72)Name of Inventor :
**1)SHARMA, Neeta Raj
2)HRUTHIK, Chinelli
3)GEHLOT, Anita
4)SINGH, Rajesh
5)SINGH, Jaskaran**

(57) Abstract :

The present invention discloses a novel system for automatic self stirring of vessel. User can do stirring using internet. The system consists of a utensil lid (102), steel stirs, a lid motor (103), a utensil motor (104), a motor driver (105), a micro controller (101), a WiFi modem (106), a cloud server (107) and a mobile application (108). The system eliminates step of manual stirring while cooking.

No. of Pages : 15 No. of Claims : 6

(12) PATENT APPLICATION PUBLICATION

(21) Application
No.201911048901 A

(19) INDIA

(22) Date of filing of Application :28/11/2019

(43) Publication Date :
20/12/2019

(54) Title of the invention : A COMFORTABLE TRAVEL CHAIR TO PREVENT MOTION SICKNESS

(51)
International :G01C0017380000,G01C0015000000,B62D0013020000,G02F0001150000,A61M0021000000
classification
(31) Priority
Document :NA
No
(32) Priority :NA
Date
(33) Name
of priority :NA
country
(86)
International
Application :NA
No :NA
Filing
Date
(87)
International : NA
Publication
No
(61) Patent
of Addition
to :NA
Application :NA
Number :NA
Filing
Date
(62)
Divisional to
Application :NA
Number :NA
Filing
Date

(71)Name of Applicant
:
**1)Lovely professional
University**
Address of
Applicant :Lovely
Professional University,
Jalandhar-Delhi GT
road Phagwara- 144411
Punjab India
(72)Name of Inventor :
**1)Mandeep Singh
2)Ruhul Amin
Choudhry
3)Dr Lovi Raj Gupta**

(57) Abstract :

Disclosed is a comfortable chair which remains stable during tilting angles and turning angles and protect traveler from motion sickness. The present invention consists of gyroscope with levitating axle and stepper motor controlled vertical shaft attached to disc, digital compass sensor, control unit, ball bearing based rotary axis and gear assembly, power source, stepper motors and controllers. The present invention remains the chair stable in vertical and horizontal angle as set by the passenger during the start of journey till end of journey.

No. of Pages : 14 No. of Claims : 6

(12) PATENT APPLICATION PUBLICATION

(21) Application
No.201911048973 A

(19) INDIA

(22) Date of filing of Application :28/11/2019

(43) Publication Date :
20/12/2019

(54) Title of the invention : AN ADJUSTABLE CIRCULAR DEVICE FOR PEELING

(51)
International :H01M0004040000,A23N0007020000,A47J0017180000,A47J0017140000,C02F0001467000
classification

(31) Priority
Document :NA
No

(32) Priority
Date :NA

(33) Name
of priority :NA
country

(86)
International
Application :NA
No :NA

Filing
Date

(87)
International
Publication : NA
No

(61) Patent
of Addition
to
Application :NA
Number :NA

Filing
Date

(62)
Divisional to
Application :NA
Number :NA

Filing
Date

(71)Name of Applicant :
**1)Lovely professional
University**

Address of Applicant
:Lovely Professional
University, Jalandhar-
Delhi GT road Phagwara-
144411 Punjab India

(72)Name of Inventor :
**1)Piyush Gulati
2)Manpreet Singh
3)Rajeev Kumar
4)Jai inder Preet
Singh**

(57) Abstract :

A novel device of peeling fruits and vegetables in a single step which has plurality of blades, a circular circumference, nuts and bolts for adjusting the size as per the requirements and spring for flexibility.

No. of Pages : 10 No. of Claims : 5

(12) PATENT APPLICATION PUBLICATION

(21) Application
No.201911048974 A

(19) INDIA

(22) Date of filing of Application :28/11/2019

(43) Publication Date :
20/12/2019

(54) Title of the invention : A SYSTEM FOR REDUCING CAUSALITY AT CONSTRUCTION SITE USING MACHINE LEARNING

(51)
International :G08B0021020000,G06N0020000000,G06Q0010060000,G05D0001000000,G06Q0050080000
classification

(31) Priority
Document :NA
No

(32) Priority :NA
Date

(33) Name
of priority :NA
country

(86)
International
Application :NA
No :NA

Filing
Date

(87)
International : NA
Publication
No

(61) Patent
of Addition
to
Application :NA
Number :NA

Filing
Date

(62)
Divisional to
Application :NA
Number :NA

Filing
Date

(71)Name of Applicant
:

**1)Lovely
professional
University**
Address of
Applicant :Lovely
Professional University,
Jalandhar-Delhi GT
road Phagwara- 144411
Punjab India

(72)Name of Inventor :

**1)GANGISHETTY ,
Arun Kumar
2)Rajesh Singh
3)Anita Gehlot**

(57) Abstract :

A system to reduce causalities in the construction site using machine learning , where the system monitor the status of the personal protective equipment (PPE) worn by each worker at the construction site and monitor the their health parameters. The system also monitors the construction site using LoRa communication. Machine learning algorithm is used to process the data to define the safety guidelines of the workers in the construction site to reduce causalities.

No. of Pages : 23 No. of Claims : 8

(12) PATENT APPLICATION PUBLICATION

(21) Application
No.201911048977 A

(19) INDIA

(22) Date of filing of Application :28/11/2019

(43) Publication Date :
20/12/2019

(54) Title of the invention : A NOVEL PROCESS FOR SYNTHESING METAL ORGANIC FRAMEWORK

(51)
International :B22F0001000000,B82Y0030000000,C08G0018120000,C08G0018400000,B22F0009240000
classification
(31) Priority
Document :NA
No
(32) Priority :NA
Date
(33) Name
of priority :NA
country
(86)
International
Application :NA
No :NA
Filing
Date
(87)
International : NA
Publication
No
(61) Patent
of Addition
to
Application :NA
Number :NA
Filing
Date
(62)
Divisional to
Application :NA
Number :NA
Filing
Date

(71)**Name of Applicant :**
**1)Lovely Proessional
University**
Address of Applicant
:Lovely Professional
University, Jalandhar-
Delhi GT road Phagwara-
144411 Punjab India
(72)**Name of Inventor :**
**1)Dr. Chandan
Adhikari**

(57) Abstract :

A novel process for synthesis of metal organic frameworks which is simple cost effective and easy to handle. The process is using green chemistry ie without any organic solvent.

No. of Pages : 11 No. of Claims : 5

(12) PATENT APPLICATION PUBLICATION

(21) Application
No.201911049022 A

(19) INDIA

(22) Date of filing of Application :29/11/2019

(43) Publication Date :
20/12/2019

(54) Title of the invention : A NOVEL GEL FORMULATION AND PROCESS FOR ANTI-ARTHRITIC ACTIVITY

(51)
International :A61K0031120000,A61K0009000000,A61K0009060000,A61K0036906600,A61K0031560000
classification
(31) Priority
Document :NA
No
(32) Priority :NA
Date
(33) Name
of priority :NA
country
(86)
International
Application :NA
No :NA
Filing
Date
(87)
International : NA
Publication
No
(61) Patent
of Addition
to
Application :NA
Number :NA
Filing
Date
(62)
Divisional to
Application :NA
Number :NA
Filing
Date

(71)**Name of Applicant**
:
**1)Lovely
Professional
University**
Address of
Applicant :Lovely
Professional University
Jalandhar-Delhi G.T.
Road, Phagwara,
Punjab-144 411, India
Punjab India
(72)**Name of Inventor**
:
**1)BAWA, Palak
2)KUMAR, Bimlesh
3)SINGH, Sachin
Kumar
4)GULATI, Monica**

(57) Abstract :

The present invention discloses a novel gel formulation for anti-arthritis activity. The gel formulation consists of curcumin, serratiopeptidase and prednisolone-cyclodextrin complex. The curcumin and serratiopeptidase are loaded in transethosomes. The formulation has synergistic action, shows better and prolonged drug diffusion through skin and better skin retention of drug.

No. of Pages : 23 No. of Claims : 6

(12) PATENT APPLICATION PUBLICATION

(21) Application
No.201911049024 A

(19) INDIA

(22) Date of filing of Application :29/11/2019

(43) Publication Date :
20/12/2019

(54) Title of the invention : A NOVEL BIO-PESTICIDE FORMULATION OF ALLIUM AMELOPRASUM

(51)
International :A01N0063040000,A01N0063020000,A01N0065200000,A01N0065000000,B01J0031060000
classification
(31) Priority
Document :NA
No
(32) Priority :NA
Date
(33) Name
of priority :NA
country
(86)
International
Application :NA
No :NA
Filing
Date
(87)
International
Publication : NA
No
(61) Patent
of Addition
to
Application :NA
Number :NA
Filing
Date
(62)
Divisional to
Application :NA
Number :NA
Filing
Date

(71)**Name of Applicant**
:
**1)Lovely Professional
University**
Address of Applicant
:Lovely Professional
University Jalandhar-
Delhi G.T. Road,
Phagwara, Punjab-144
411, India Punjab India
(72)**Name of Inventor :**
**1)SHARMA, Neeta
Raj**
2)KAUR, Amandeep
3)KHAN, Shahid
4)SINGH, Jaskaran
5)DUTTA, Joydeep
6)BANU, Najitha

(57) Abstract :

The present invention discloses a novel bio-pesticide formulation of Allium ameloprasum. The said formulation is eco-friendly, cost-effective and easy to prepare.

No. of Pages : 16 No. of Claims : 5

(12) PATENT APPLICATION PUBLICATION

(21) Application
No.201911049025 A

(19) INDIA

(22) Date of filing of Application :29/11/2019

(43) Publication Date :
20/12/2019

(54) Title of the invention : A NOVEL ANTI-THEFT SYSTEM WITH REAL TIME NOTIFICATION

(51)
International :H04W0084120000,H04L0029080000,H03K0005080000,B60N0002000000,H04W0056000000
classification

(31) Priority
Document :NA
No

(32) Priority
Date :NA

(33) Name
of priority :NA
country

(86)
International
Application :NA
No :NA

Filing
Date

(87)
International
Publication : NA
No

(61) Patent
of Addition
to

Application :NA
Number :NA

Filing
Date

(62)
Divisional to
Application :NA

Number :NA

Filing
Date

(71)**Name of Applicant :**
1)Lovely Professional University
Address of Applicant :Lovely Professional University
Jalandhar-Delhi G.T. Road, Phagwara, Punjab-144 411, India
Punjab India
(72)**Name of Inventor :**
1)SINGH, Dushyant Kumar
2)RAJA, P.
3)JERATH, Himani
4)SINGH, Kanwaljeet

(57) Abstract :

The present invention discloses a novel anti-theft system with real time notification. Disclosed is a novel anti-theft system with real time notification. The system consists of plurality of Wi-Fi access point, central node, actuator, IoT enabled communication system and alert system. Whenever signal strength scanned by the central node is below a threshold then the central node send signals to the alert system through the IoT enable communication. The system is low cost.

No. of Pages : 14 No. of Claims : 5

(12) PATENT APPLICATION PUBLICATION

(21) Application
No.201911049027 A

(19) INDIA

(22) Date of filing of Application :29/11/2019

(43) Publication Date :
20/12/2019

(54) Title of the invention : A NOVEL PROTEIN RICH DIETARY FORMULATION AND PROCESS THEREOF

(51)
International :A61K0009200000,A61K0047260000,A61K0009160000,A61K0047020000,A23K0020147000
classification
(31) Priority
Document :NA
No
(32) Priority :NA
Date
(33) Name
of priority :NA
country
(86)
International
Application :NA
No :NA
Filing
Date
(87)
International
Publication : NA
No
(61) Patent
of Addition
to
Application :NA
Number :NA
Filing
Date
(62)
Divisional to
Application :NA
Number :NA
Filing
Date

(71)**Name of Applicant**
:
**1)Lovely
Professional
University**
Address of
Applicant
:dip@lpu.co.in Punjab
India
(72)**Name of Inventor**
:
**1)SINGH, Jyoti
2)RASANE, Prasad
3)MEHTA, Chandra
Mohan
4)KAUR, Sawinder**

(57) Abstract :

The present invention discloses a novel protein enriched dietary formulation and process thereof. The process of formulation is simple and cost effective. No extra protein source is used in the preparation of the formulation.

No. of Pages : 10 No. of Claims : 5

(12) PATENT APPLICATION PUBLICATION

(21) Application
No.201911049028 A

(19) INDIA

(22) Date of filing of Application :29/11/2019

(43) Publication Date :
20/12/2019

(54) Title of the invention : AI ASSISTED PORTABLE E-BLOOD TESTER FOR DETECTION OF MALARIA PARASITEMIA

(51)
International :B67D0001080000,G06Q0030040000,H04N0005359000,G01N0001280000,C12N0015820000
classification
(31) Priority
Document :NA
No
(32) Priority :NA
Date
(33) Name
of priority :NA
country
(86)
International
Application :NA
No :NA
Filing
Date
(87)
International : NA
Publication
No
(61) Patent
of Addition
to
Application :NA
Number :NA
Filing
Date
(62)
Divisional to
Application :NA
Number :NA
Filing
Date

(71)**Name of Applicant**
:
**1)Lovely
Professional
University**
Address of
Applicant :Lovely
Professional University
Jalandhar-Delhi G.T.
Road, Phagwara,
Punjab-144 411, India
Punjab India
(72)**Name of Inventor :**
**1)SWAIN,
Mahendra**
2)KUMAR, Gaurav
3)SINGH, Rajesh
4)GEHLOT, Anita

(57) Abstract :

Disclosed is a portable e-blood tester for calculation of parasitemia in blood smear using artificial intelligence. The present invention consists of a USB Camera, a Raspberry pi, and a battery and uses a Python based image processing tool for parasitemia calculation in blood smear. The present invention works with or without internet and is IoT enabled to store the data to the cloud for further use. The present invention facilitates a customized, portable and cost-effective solution.

No. of Pages : 13 No. of Claims : 5

(12) PATENT APPLICATION PUBLICATION

(21) Application
No.201911049029 A

(19) INDIA

(22) Date of filing of Application :29/11/2019

(43) Publication Date :
20/12/2019

(54) Title of the invention : A NOVEL FORMULATION OF 5-FLUOROURACIL FOR TREATING DIABETIC RETINOPATHY

(51)
International :A61K0009000000,A61K0031513000,A61K0031402500,A61K0009160000,A61B0005145500

classification

(31) Priority

Document :NA

No

(32) Priority :NA

Date

(33) Name

of priority :NA

country

(86)

International

Application :NA

No :NA

Filing

Date

(87)

International : NA

Publication

No

(61) Patent

of Addition

to :NA

Application :NA

Number

Filing

Date

(62)

Divisional to

Application :NA

Number :NA

Filing

Date

(71)Name of Applicant
:

**1)Lovely
Professional
University**

Address of
Applicant :Lovely
Professional University
Jalandhar-Delhi G.T.
Road, Phagwara,
Punjab-144 411, India
Punjab India

(72)Name of Inventor :

**1)SHARMA, Deep
Shikha**

2)Sheetu

**3)SINGH, Sachin
Kumar**

(57) Abstract :

The present invention discloses a novel formulation of 5-fluorouracil for treating diabetic retinopathy. The formulation is applied topically by non-invasive method by patient itself. The formulation consists of 5-fluorouracil loaded in the nano liquid carrier.

No. of Pages : 14 No. of Claims : 6

(12) PATENT APPLICATION PUBLICATION

(21) Application
No.201911049030 A

(19) INDIA

(22) Date of filing of Application :29/11/2019

(43) Publication Date :
20/12/2019

(54) Title of the invention : SMART POLE TO AVOID AND REPORT ACCIDENT IN HILLY AREA

(51)
International :F21S0009030000,H02J0007350000,F21S0008080000,H02S0040380000,C04B0035645000
classification
(31) Priority
Document :NA
No
(32) Priority :NA
Date
(33) Name
of priority :NA
country
(86)
International
Application :NA
No :NA
Filing
Date
(87)
International
Publication : NA
No
(61) Patent
of Addition
to
Application :NA
Number :NA
Filing
Date
(62)
Divisional to
Application :NA
Number :NA
Filing
Date

(71)**Name of Applicant :**
**1)Lovely Professional
University**
Address of Applicant
:Lovely Professional
University Jalandhar-Delhi
G.T. Road, Phagwara,
Punjab-144 411, India
Punjab India
(72)**Name of Inventor :**
1)GEHLOT, Anita
2)SINGH, Rajesh
3)GUPTA, Lovi Raj
4)DAS, Prabin Kumar
5)GUPTA, Km
Vaishnavi

(57) Abstract :

Disclosed is a smart pole with inbuilt incoming vehicle alert mechanism which consists of a weather report unit, a vehicle sensing unit, a LED's, a solar panel and charging system, and a cloud server in which poles communicates with each other by RF communication and information related to any accident report with location to the cloud server using GPRS. The present invention uses more than one intelligent poles and each pole communicates with nearby pole with RF communication modules and indicates the approaching of vehicle from other side of blind curve. The present invention provides safety measures by creating awareness to the passengers about blind turns in hilly areas.

No. of Pages : 16 No. of Claims : 10

(12) PATENT APPLICATION PUBLICATION

(21) Application
No.201911049031 A

(19) INDIA

(22) Date of filing of Application :29/11/2019

(43) Publication Date :
20/12/2019

(54) Title of the invention : A PORTABLE SPRAY CAN FOR VITRIOL ATTACK VICTIMS

(51)
International :A61K0031439000,C05D0009020000,A61K0031000000,G01N0021640000,A61H0009000000
classification
(31) Priority
Document :NA
No
(32) Priority :NA
Date
(33) Name
of priority :NA
country
(86)
International
Application :NA
No :NA
Filing
Date
(87)
International : NA
Publication
No
(61) Patent
of Addition
to
Application :NA
Number :NA
Filing
Date
(62)
Divisional to
Application :NA
Number :NA
Filing
Date

(71)**Name of Applicant**
:
**1)Lovely
Professional
University**
Address of
Applicant :Lovely
Professional University
Jalandhar-Delhi G.T.
Road, Phagwara,
Punjab-144 411, India
Punjab India
(72)**Name of Inventor :**
**1)SINGH, Mandeep
2)CHOUDHURY,
Ruhul Amin
3)JAYAKODY, J.A
Ravishka lakmi
4)ADHIKARI,
Chandan**

(57) Abstract :

Disclosed is a portable spray can for vitriol attack victims which consists of sodium bicarbonate and silver nitrate nano particle solution in 1:1 ratio in liquid form stores in pressurized chamber and protects acid attack skin from severely burning. The present invention neutralizes the effect of acid and save skin from extreme burning if sprays solution within some seconds.

No. of Pages : 9 No. of Claims : 5

(12) PATENT APPLICATION PUBLICATION

(21) Application
No.201911049032 A

(19) INDIA

(22) Date of filing of Application :29/11/2019

(43) Publication Date :
20/12/2019

(54) Title of the invention : MACHINE LEARNING ENABLED SYSTEM FOR LANDSLIDE EARLY WARNING

(51)
International :G08B0021100000,G16H0050200000,G08B0027000000,H04W0052360000,G08B0021180000
classification
(31) Priority
Document :NA
No
(32) Priority :NA
Date
(33) Name
of priority :NA
country
(86)
International
Application :NA
No :NA
Filing
Date
(87)
International : NA
Publication
No
(61) Patent
of Addition
to
Application :NA
Number :NA
Filing
Date
(62)
Divisional to
Application :NA
Number :NA
Filing
Date

(71)**Name of Applicant :**
1)Lovely Professional University
Address of Applicant :Lovely Professional University
Jalandhar-Delhi G.T.
Road, Phagwara,
Punjab-144 411, India
Punjab India
(72)**Name of Inventor :**
1)BAGWARI, Swapnil
2)GEHLOT,Anita
3)SINGH, Rajesh
4)GUPTA, Lovi Raj

(57) Abstract :

An IoT enabled device which is used to detect the changes in the landslide prone area and generate an alarm to evacuate the population from that area using early warning system. The system is enabled with machine learning technology, where the real time data set is used to analyze the current status with camera. IoT enabled communication to transmit the data in long range using LoRa to the site communication.

No. of Pages : 19 No. of Claims : 9

(12) PATENT APPLICATION PUBLICATION

(21) Application
No.201911049033 A

(19) INDIA

(22) Date of filing of Application :29/11/2019

(43) Publication Date :
20/12/2019

(54) Title of the invention : A SYSTEM FOR TRAFFIC CONTROL BASED ON MACHINE LEARNING AND ARTIFICIAL INTELLIGENCE

(51)
International :G08G0001087000,G06N0020000000,G08G0001095000,G08G0001080000,G08G0001040000
classification

(31) Priority
Document :NA
No

(32) Priority :NA
Date

(33) Name
of priority :NA
country

(86)
International
Application :NA
No :NA

Filing
Date

(87)
International : NA
Publication
No

(61) Patent
of Addition
to
Application :NA
Number :NA

Filing
Date

(62)
Divisional to
Application :NA
Number :NA

Filing
Date

(71)Name of Applicant
:

**1)Lovely
Professional
University**
Address of
Applicant :Lovely
Professional University,
Delhi Jalandhar GT
road Phagwara-
144411. Punjab India

(72)Name of Inventor
:

**1)Dushyant Kumar
Singh
2)Himani Jerath
3)P. Raja
4)Narenthira
Prasath D**

(57) Abstract :

Disclosed is a system for traffic control based on machine learning and artificial intelligence. The present invention works when user gives inputs and sends data to concerned traffic light control station, the traffic control station makes decision whether signal is received from priority vehicle or not. The present invention provides green signal to priority vehicles and regular traffic signal to others vehicle. The present invention further reduces the waiting time for priority vehicles.

No. of Pages : 12 No. of Claims : 5

(12) PATENT APPLICATION PUBLICATION

(21) Application
No.201911049040 A

(19) INDIA

(22) Date of filing of Application :29/11/2019

(43) Publication Date :
20/12/2019

(54) Title of the invention : AI POWERED BADMINTON COACH FOR RECOMMENDING TIPS TO ENHANCE THE SKILLS OF PLAYER

(51)
International :G06N0020000000,G09B0019000000,A63B0069380000,A43B0003000000,H04M0001600000
classification
(31) Priority
Document :NA
No
(32) Priority :NA
Date
(33) Name
of priority :NA
country
(86)
International
Application :NA
No :NA
Filing
Date
(87)
International : NA
Publication
No
(61) Patent
of Addition
to
Application :NA
Number :NA
Filing
Date
(62)
Divisional to
Application :NA
Number :NA
Filing
Date

(71)Name of Applicant
:

**1)Lovely
Professional
University**
Address of
Applicant :Lovely
Professional University,
Delhi Jalandhar GT
road Phagwara- 144411
Punjab India

(72)Name of Inventor
:

**1)Lovi Raj Gupta
2)Rajesh Singh
3)sakshi
4)Arjun S
5)Prateek Rathod**

(57) Abstract :

An intelligent system to help badminton players identify and correct moves by suggesting tips to improve based on their current racket movement. The system is having a detachable clip that can mount on any badminton racket. The player can start a coaching session from the companion mobile application or from the device itself and start playing. The movements on the racket are recorded during the entirety of a coaching session. Once the player is done playing, the device processes the recorded movement data using a machine learning based model specifically trained for this task and recommend changes/corrections that the player can make in their movement to improve their performance. The device also takes other factors into consideration such as the physique of the player, their dietary patterns and previous training history. The device is powered by micro lithium cells and will have an option to get replaced/rechargeable.

No. of Pages : 17 No. of Claims : 6

(12) PATENT APPLICATION PUBLICATION

(21) Application
No.201911049041 A

(19) INDIA

(22) Date of filing of Application :29/11/2019

(43) Publication Date :
20/12/2019

(54) Title of the invention : AN IOT ASSISTED WALL CLIMBING ROBOT FOR SECURITY AND INSPECTION

(51)
International :B25J0009160000,B25J0005000000,H04N0005330000,G05B0019408000,B62D0057024000
classification

(31) Priority
Document :NA
No

(32) Priority
Date :NA

(33) Name
of priority :NA
country

(86)
International
Application :NA
No :NA

Filing
Date

(87)
International
Publication : NA
No

(61) Patent
of Addition
to
Application :NA
Number :NA

Filing
Date

(62)
Divisional to
Application :NA
Number :NA

Filing
Date

(71)Name of Applicant :
**1)Lovely Professional
University**

Address of Applicant
:Lovely Professional
University, Delhi
Jalandhar GT road
Phagwara- 144411 Punjab
India

(72)Name of Inventor :
**1)Rajesh Singh
2)Anita Gehlot
3)Lovi Raj Gupta
4)Dharam Buddhi
5)Amit Kumar Thakur**

(57) Abstract :

A wall climbing robot assisted by IoT cloud server which is capable of climbing vertical and inclined terrains consists of plurality of components. Here, the robot is controlled by Raspberry Pi which is the Central Processing Unit through the instructions received from the earth station, and earth station uploads the data to the cloud server through NodeMCU platform. Here, the color camera is used for supervising the robot and for identifying geometrical features and the thermal imaging camera is used to plot the statistical image data. The robot is capable of inspecting complex three dimensional surfaces.

No. of Pages : 17 No. of Claims : 8

(12) PATENT APPLICATION PUBLICATION

(21) Application
No.201911049042 A

(19) INDIA

(22) Date of filing of Application :29/11/2019

(43) Publication Date :
20/12/2019

(54) Title of the invention : A NOVEL COLOR CODED TAGS FOR TEA BAGS

(51)
International :A23L0033105000,G02F0001133500,B65D0085812000,B65D0085808000,G02B0005200000
classification
(31) Priority
Document :NA
No
(32) Priority
Date :NA
(33) Name
of priority :NA
country
(86)
International
Application :NA
No :NA
Filing
Date
(87)
International
Publication : NA
No
(61) Patent
of Addition
to
Application :NA
Number :NA
Filing
Date
(62)
Divisional to
Application :NA
Number :NA
Filing
Date

(71)**Name of Applicant**
:
**1)Lovely Professional
University**
Address of Applicant
:Lovely Professional
University, Delhi
Jalandhar GT road
Phagwara- 144411
Punjab India
(72)**Name of Inventor :**
1)Rasane Prasad
**2)Chandra Mohan
Mehta**
3)Jyoti Singh
4)Sawinder Kaur

(57) Abstract :

The present invention discloses a color coded tag attached to the tea bag to denote the extraction of the most probable quantity of the stated phytochemicals in the tea or coffee extracts. The color formed of the extract could be associated with the probable quantity of these nutrients in the tea or coffee extracts. The present invention provides information probable quantity of the consumed phytochemicals could be conveyed to the consumer.

No. of Pages : 13 No. of Claims : 5

(12) PATENT APPLICATION PUBLICATION

(21) Application
No.201911049057 A

(19) INDIA

(22) Date of filing of Application :29/11/2019

(43) Publication Date :
20/12/2019

(54) Title of the invention : SPEAKER BAG

(51)
International :H04R0009020000,G10L0017000000,G10L0017020000,H04R0001020000,H04N0019200000
classification
(31) Priority
Document :NA
No
(32) Priority :NA
Date
(33) Name
of priority :NA
country
(86)
International
Application :NA
No :NA
Filing
Date
(87)
International : NA
Publication
No
(61) Patent
of Addition
to
Application :NA
Number :NA
Filing
Date
(62)
Divisional to
Application :NA
Number :NA
Filing
Date

(71)Name of Applicant
:
**1)RAHUL
THAREJA**
Address of Applicant
:A-177, SHIVALIK,
MALVIYA NAGAR,
NEW DELHI DELHI-
110017, INDIA Delhi
India
(72)Name of Inventor :
**1)RAHUL
THAREJA**

(57) Abstract :

The invention is a bag fitted speakers connected to 40 watt amplifier with the battery backup of two hours. The playback time can be extended by increasing the current provided by attaching more batteries in parallel to the main battery. Methods of input are aux and external Bluetooth receiver Amplifier uses CD 6283 integrated circuit best rated for 9 to 12 volts provide up to 40 watt output. The speakers are Sony xplod XS GF 1662, which has rated power output of 40 watt. Battery used in ICAR 18650 lithium ion cell which has a voltage of 3.7 volts. To provide the desired voltage of 12 volts three cells are connected in series which make it 11.1 volts. The output current of the battery is 2600 mAh.

No. of Pages : 14 No. of Claims : 5

(12) PATENT APPLICATION PUBLICATION

(21) Application
No.201911049193 A

(19) INDIA

(22) Date of filing of Application :29/11/2019

(43) Publication Date :
20/12/2019

(54) Title of the invention : A NOVEL MULTIBAND HYBRID FRACTAL ANTENNA WITH PARASITIC ELEMENT

<p>(51) International :H01Q0005385000,H01Q0001360000,H01Q0009260000,H01Q0009400000,H01Q0015120000 classification (31) Priority Document :NA No (32) Priority :NA Date (33) Name of priority :NA country (86) International Application :NA No :NA Filing Date (87) International Publication : NA No (61) Patent of Addition to Application :NA Number :NA Filing Date (62) Divisional to Application :NA Number :NA Filing Date</p>	<p>(71)Name of Applicant : 1)Ashima Aggarwal Address of Applicant :ECE Dept. CCET (Degree Wing) Sector 26, Chandigarh Chandigarh India 2)Divya 3)Prachi Madan 4)Krishna Gopal Sharma 5)Anil Kumar 6)Bhaskar Gupta 7)Dinesh Sharma 8)Purnima K Sharma 9)Davinder Singh Saini (72)Name of Inventor : 1)Ashima Aggarwal 2)Divya 3)Prachi Madan 4)Krishna Gopal Sharma 5)Anil Kumar 6)Bhaskar Gupta 7)Dinesh Sharma 8)Purnima K Sharma 9)Davinder Singh Saini</p>
--	---

(57) Abstract :

The invention is based primarily on two established principles, one based on the cost-benefit factor and another on utility analysis. Here, a single antenna (to minimize hardware) for multiple applications (to maximize utility) has been designed. It illustrates a novel hybrid fractal multiband antenna for wireless communications that works on the frequency bands, 5-10GHz. The antenna design is a structural shift yielding positive results on frequencies 5.6GHz, 6.5GHz, 7.2GHz, 7.6GHz, 8.5GHz, 9GHz and 9.5GHz and it can be used for several applications at one go. The proposed hybrid fractal antenna consists of radiating plane and defected ground plane with parasitic elements. The parasitic elements and defected ground gives profitable gain and reflection coefficient. The antenna fabricated on FR4 epoxy board and the main dimensions of proposed antenna is 140x66x1.6 mm. Thus, the proposed antenna is recommended for energy harvesting, satellite, WiMAX, Wi-Fi, WLAN and Radar applications.

No. of Pages : 17 No. of Claims : 8

(12) PATENT APPLICATION PUBLICATION

(21) Application
No.201911049236 A

(19) INDIA

(22) Date of filing of Application :29/11/2019

(43) Publication Date :
20/12/2019

(54) Title of the invention : HARDWARE ACCELERATION SYSTEM, DEVICE AND METHOD FOR CRYPTOGRAPHIC TRANSACTIONS

(51)
International :H04L0029060000,G09C0001000000,G06F0013160000,G06F0013280000,H04L0029080000
classification

(31) Priority
Document :NA
No

(32) Priority :NA
Date

(33) Name
of priority :NA
country

(86)
International
Application :NA
No :NA

Filing
Date

(87)
International : NA
Publication
No

(61) Patent
of Addition
to
Application :NA
Number :NA

Filing
Date

(62)
Divisional to
Application :NA
Number :NA

Filing
Date

(71)**Name of Applicant :**
**1)INDIAN
INSTITUTE OF
TECHNOLOGY
KANPUR**

Address of Applicant
:Dean, Research &
Development, Room
Number 151, Faculty
Building, Post Office: IIT
Kanpur, Kanpur -
208016, Uttar Pradesh,
India Uttar Pradesh India

(72)**Name of Inventor :**
**1)MITRA, Jubin
2)SHUKLA, Sandeep
K.
3)AGRAWAL,
Manindra**

(57) Abstract :

The present invention is directed towards a unified firmware design architecture for cryptographic acceleration. It enables an FPGA-based development card to deliver enhanced performance for cyber-security applications. The firmware design can handle the plurality of link interfaces and multiplicity of communication channels for multiple cryptographic transactions to happen while maintaining maximum throughput and minimum latency. Present design architecture of the hardware accelerator includes eight processing channels bridged to the socket addresses of the transport layer (UDP). Protocol layer of hardware accelerator allows multiple command queues to prioritize traffic, to avoid overprovisioning and enforce higher priority for performance-critical applications. Apart from the single session management, the hardware accelerator has provisions for distributed and shared session management. This leading-edge firmware design minimizes the logic resource footprint required for variety of cryptographic function implementation. The proposed design for proof of concept is tested with a single link of 10Gbps having only the hashing functions. The design is tested for resilience under stress by exposing to full load of data traffic and monitoring the processing channels performance along with its throttling capability. (FIGURE 1)

No. of Pages : 66 No. of Claims : 14

(12) PATENT APPLICATION PUBLICATION

(21) Application
No.201911049253 A

(19) INDIA

(22) Date of filing of Application :29/11/2019

(43) Publication Date :
20/12/2019

(54) Title of the invention : AN INTELLIGENT SYSTEM FOR HOME ASSISTANCE

<p>(51) International :A63H0018020000,A63H0018160000,H04Q0009000000,G09B0019060000,H04W0004020000 classification (31) Priority Document :NA No (32) Priority :NA Date (33) Name of priority :NA country (86) International Application :NA No :NA Filing Date (87) International Publication : NA No (61) Patent of Addition to Application :NA Number :NA Filing Date (62) Divisional to Application :NA Number :NA Filing Date</p>	<p>(71)Name of Applicant : 1)Lovely Professional University Address of Applicant :Lovely Professional University Jalandhar-Delhi G.T. Road, Phagwara, Punjab-144 411, India Punjab India (72)Name of Inventor : 1)GEHLOT, Anita 2)SINGH, Rajesh 3)GUPTA, Lovi Raj 4)TEJA, Medisetty Arun Sai 5)KALANGI, Jithin Sri Sai</p>
--	--

(57) Abstract :

In the present invention, the whole setup of microcontroller and sensor unit is incorporated into an outer attractive structure of a soft toy. This system is capable of communicating in our native language and is also capable of finding the inner atmospheric parameters like air quality, humidity and temperature in homes and also it helps in maintaining the standard human comfortable parameters. This is also helps in garden monitoring, door and window curtains monitoring according to conditions. The system is integrated with Google assistant and can be controlled with mobile phone with in taking voice commands.

No. of Pages : 11 No. of Claims : 8

(12) PATENT APPLICATION PUBLICATION

(21) Application
No.201911049254 A

(19) INDIA

(22) Date of filing of Application :29/11/2019

(43) Publication Date :
20/12/2019

(54) Title of the invention : SMART VENTILATION SYSTEM FOR VEHICLES PARKED IN THE SUN

(51)
International :G08G0001160000,G01S0015930000,G07C0005080000,B60R0016030000,G08G0005040000
classification
(31) Priority
Document :NA
No
(32) Priority
Date :NA
(33) Name
of priority :NA
country
(86)
International
Application :NA
No :NA
Filing
Date
(87)
International
Publication : NA
No
(61) Patent
of Addition
to
Application :NA
Number :NA
Filing
Date
(62)
Divisional to
Application :NA
Number :NA
Filing
Date

(71)**Name of Applicant**
:
**1)Lovely professional
University**
Address of Applicant
:Lovely Professional
University, Jalandhar-
Delhi GT road
Phagwara- 144411
Punjab India
(72)**Name of Inventor :**
1)Dr Lovi Raj Gupta
2)Prasanth Kumar
3)Dr. Jaskaran Singh
4)Mahesh Kumar
Prajapat

(57) Abstract :

A novel system for ventilation of parked vehicles wherein the system works as an independent entity and can be installed in any vehicle. The system works with plurality of sensors, fans and is battery assisted.

No. of Pages : 11 No. of Claims : 5

(12) PATENT APPLICATION PUBLICATION

(21) Application
No.201911049255 A

(19) INDIA

(22) Date of filing of Application :29/11/2019

(43) Publication Date :
20/12/2019

(54) Title of the invention : AN IOT ASSISTED FIRE EXTINGUISHER MONITORING SYSTEM

(51)
International :G09B0019000000,A42B0003040000,A61B0005040200,G06F0021830000,G01L0005000000
classification
(31) Priority
Document :NA
No
(32) Priority :NA
Date
(33) Name
of priority :NA
country
(86)
International
Application :NA
No :NA
Filing
Date
(87)
International
Publication : NA
No
(61) Patent
of Addition
to
Application :NA
Number :NA
Filing
Date
(62)
Divisional to
Application :NA
Number :NA
Filing
Date

(71)**Name of Applicant**
:
**1)Lovely Professional
University**
Address of Applicant
:Lovely Professional
University Jalandhar-
Delhi G.T. Road,
Phagwara, Punjab-144
411, India Punjab India
(72)**Name of Inventor :**
**1)BIRAJDAR,
Gajanand Sharanappa**
2)SINGH, Rajesh
3)GEHLOT, Anita
4)BUDDHI, Dharam

(57) Abstract :

The system consists of a microcontroller, pressure sensor, proximity sensor, impact sensor and node MCU .Microcontroller senses the data of different sensors and processes it through smart algorithm. Finally processed data is transferred to cloud server through node MCU. In the present system, embedded systems, cloud technology is used for real time monitoring and inspection of fire extinguishers is done.

No. of Pages : 15 No. of Claims : 7

(12) PATENT APPLICATION PUBLICATION

(21) Application
No.201911049257 A

(19) INDIA

(22) Date of filing of Application :29/11/2019

(43) Publication Date :
20/12/2019

(54) Title of the invention : AN INTELLIGENT SYSTEM TO CAPTURE WILD-LIFE PHOTOGRAPH USING MACHINE LEARNING

(51)
International :H04N0001000000,H04N0001210000,A01K0005020000,G01N0033487000,B25J0009160000
classification
(31) Priority
Document :NA
No
(32) Priority :NA
Date
(33) Name
of priority :NA
country
(86)
International
Application :NA
No :NA
Filing
Date
(87)
International : NA
Publication
No
(61) Patent
of Addition
to
Application :NA
Number :NA
Filing
Date
(62)
Divisional to
Application :NA
Number :NA
Filing
Date

(71)**Name of Applicant**
:
1)Lovely Professional University
Address of Applicant
:Lovely Professional University Jalandhar- Delhi G.T. Road, Phagwara, Punjab-144 411, India Punjab India
(72)**Name of Inventor** :
1)SINGH, Rajesh
2)GEHLOT,Anita
3)GUPTA, Lovi Raj
4)AKRAM , VaseemShaik
5)DAS, Prabin Kumar
6)RATHOUR,Navjot

(57) Abstract :

A system to automatically capture the photograph of an animal approaching receiving the data by sensing the animal approaching and uploading them to the cloud without human interference. Cloud server is used to connected with personalized GMAIL or Dropbox the image/video will be uploaded automatically upon authentication by the user.

No. of Pages : 15 No. of Claims : 8

(12) PATENT APPLICATION PUBLICATION

(21) Application
No.201911049259 A

(19) INDIA

(22) Date of filing of Application :29/11/2019

(43) Publication Date :
20/12/2019

(54) Title of the invention : A NOVEL SHOES SPATULA WITH CLEANER

(51)
International :A47L0023050000,A47J0043280000,A61K0031000000,A01F0012440000,D21G0001000000
classification
(31) Priority
Document :NA
No
(32) Priority :NA
Date
(33) Name
of priority :NA
country
(86)
International
Application :NA
No :NA
Filing
Date
(87)
International
Publication : NA
No
(61) Patent
of Addition
to
Application :NA
Number :NA
Filing
Date
(62)
Divisional to
Application :NA
Number :NA
Filing
Date

(71)**Name of Applicant :**
**1)Lovely Professional
University**
Address of Applicant
:Lovely Professional
University Jalandhar-
Delhi G.T. Road,
Phagwara, Punjab-144
411, India Punjab India
(72)**Name of Inventor :**
1)SINGH, Satnam
2)BAHL, Ankur
**3)SINGH, Jaiinder
Preet**
4)GULATI, Piyush
5)SINGH, Manpreet

(57) Abstract :

The shoe spatula with cleaner which is provided with an expandable stick attached to a shoe spatula and a brush with neutral polish liquid embedded in it. The shoe spatula helps in wearing the shoe and the neutral polish brush helps us in cleaning the shoe without bending. In the present invention, the height of cleaner can be adjusted with the help of adjuster (3). As per present invention, the arrangement can be folded and can be carried conveniently in bags or even in pockets.

No. of Pages : 11 No. of Claims : 5

(12) PATENT APPLICATION PUBLICATION

(21) Application
No.201911049261 A

(19) INDIA

(22) Date of filing of Application :29/11/2019

(43) Publication Date :
20/12/2019

(54) Title of the invention : A SMART MOSQUITO REPELLENT DEVICE

(51)
International :H02J0003140000,G05B0015020000,A63B0071060000,H04Q0009000000,A01M0007000000
classification

(31) Priority
Document :NA
No

(32) Priority
Date :NA

(33) Name
of priority :NA
country

(86)
International
Application :NA
No :NA

Filing
Date

(87)
International
Publication : NA
No

(61) Patent
of Addition
to
Application :NA
Number :NA

Filing
Date

(62)
Divisional to
Application :NA
Number :NA

Filing
Date

(71)**Name of Applicant**
:
**1)Lovely Professional
University**

Address of
Applicant :Lovely
Professional University
Jalandhar-Delhi G.T.
Road, Phagwara,
Punjab-144 411, India
Punjab India

(72)**Name of Inventor :**
**1)SINGH, Jaiinder
Preet**

2)SYAVE, Umesh
3)GULATI, Piyush
4)SINGH, Manpreet
5)SINGH, Satnam
6)SINGH, Rajesh

(57) Abstract :

A smart mosquito repellent device consisting of a mosquito repellent equipment, real time clock, microcontroller, relay, electric power supply, ON/OFF mechanism of equipment and display LED. The mosquito repellent equipment inserted into the electric board and person will feed the start time and the end time of the equipment on the real time clock and hence with the help of microcontroller and relays, the equipment would start and stop automatically. This device is capable of preventing the wastage of chemical substance inside the machine and also ensures humans from the potential danger of extra inhalation of chemicals.

No. of Pages : 11 No. of Claims : 5

(12) PATENT APPLICATION PUBLICATION

(21) Application
No.201911049262 A

(19) INDIA

(22) Date of filing of Application :29/11/2019

(43) Publication Date :
20/12/2019

(54) Title of the invention : A FACIAL RECOGNITION LOCKING SYSTEM FOR TWO-WHEELERS WITH SECURITY ALERT

(51)
International :G06K0009000000,B60R0025040000,B60R0025100000,B60R0025250000,G06F0021320000
classification
(31) Priority
Document :NA
No
(32) Priority :NA
Date
(33) Name
of priority :NA
country
(86)
International
Application :NA
No :NA
Filing
Date
(87)
International
Publication : NA
No
(61) Patent
of Addition
to
Application :NA
Number :NA
Filing
Date
(62)
Divisional to
Application :NA
Number :NA
Filing
Date

(71)**Name of Applicant**
:
**1)Lovely Professional
University**
Address of Applicant
:Lovely Professional
University Jalandhar-
Delhi G.T. Road,
Phagwara, Punjab-144
411, India Punjab India
(72)**Name of Inventor** :
1)GAIN, Saurabh
**2)BAGWARI,
Swapnil**
3)GEHLOT, Anita
4)SINGH, Rajesh

(57) Abstract :

A novel system of facial recognition which is used for locking the two wheeler vehicle with security alert consists of a controller unit, camera and a servo mounted on a vehicle. To operate the vehicle, a person has to authenticate himself using fingerprint sensor of the smartphone, if the fingerprint of the person is matched with already existed database of authorized person, then camera is activated using a servo and image is captured using the camera. The captured image is processed in the microcontroller and matched with database of images of authorized drivers. If image is matched, it turns on the ignition system of vehicle. If image is not matched, an alert notification is sent to owner and operation of vehicle is disabled to prevent theft of the vehicle or operation of vehicle by unauthorized persons.

No. of Pages : 13 No. of Claims : 6

(12) PATENT APPLICATION PUBLICATION

(21) Application
No.201911049263 A

(19) INDIA

(22) Date of filing of Application :29/11/2019

(43) Publication Date :
20/12/2019

(54) Title of the invention : SYSTEM AND METHOD FOR ASSISTING MOBILITY

(51)
International :A61B0005000000,A61B0005049600,A61H0003000000,A61B0005048800,A61B0005047800
classification

(31) Priority
Document :NA
No

(32) Priority
Date :NA

(33) Name
of priority :NA
country

(86)
International
Application :NA
No :NA

Filing
Date

(87)
International
Publication : NA
No

(61) Patent
of Addition
to
Application :NA
Number :NA

Filing
Date

(62)
Divisional to
Application :NA
Number :NA

Filing
Date

(71)Name of Applicant
:

**1)YOGENDRA
NARAYAN**
Address of
Applicant :(Assistant
Professor, ECE Deptt.,
Chandigarh University,
Research Scholar -
NITTTR Chandigarh)
R/O House no. 295,
Village Mustafabad,
Post Pachenda Kalan,
Distt. Muzaffarnagar,
Uttar pradesh, India, Pin
Code-251001; Uttar
Pradesh India

**2)SIDDHESHWARI
DUTT MISHRA**

(72)Name of Inventor :

**1)YOGENDRA
NARAYAN**
**2)SIDDHESHWARI
DUTT MISHRA**

(57) Abstract :

A system for assisting mobility to a user comprising an exoskeleton suit to be worn by the user, an EEG, SEMG and EOG signals acquisition units mounted on the user for collecting user's EEG, SEMG and EOG signals, a signal acquisition module capable of receiving the EEG, SEMG and EOG signals collected by the EEG, SEMG and EOG signals acquisition units, an enhancing module configured to pre-process the EEG, SEMG and EOG signals simultaneously, a post-processing module configured to provide movement to the exoskeleton suit. Further, the post processing module actuates the exoskeleton suit as per bio-medical signals given by the user.

No. of Pages : 28 No. of Claims : 10

(12) PATENT APPLICATION PUBLICATION

(21) Application
No.201911049281 A

(19) INDIA

(22) Date of filing of Application :30/11/2019

(43) Publication Date :
20/12/2019

(54) Title of the invention : IOT ENABLED TIMETABLE TRIGGERED POWER SAVING AND SECURITY DEVICE FOR CLASS ROOMS

(51)
International :B61L0027000000,G06F0008650000,H04N0005630000,G06F0008710000,H04N0021840000
classification
(31) Priority
Document :NA
No
(32) Priority :NA
Date
(33) Name
of priority :NA
country
(86)
International
Application :NA
No :NA
Filing
Date
(87)
International : NA
Publication
No
(61) Patent
of Addition
to
Application :NA
Number :NA
Filing
Date
(62)
Divisional to
Application :NA
Number :NA
Filing
Date

(71)**Name of Applicant**
:
**1)Lovely professional
University**
Address of Applicant
:Lovely Professional
University, Jalandhar-
Delhi GT road
Phagwara- 144411
Punjab India
(72)**Name of Inventor :**
1)Botta Ramana
2)P Raja
3)Dr Lovi Raj Gupta
4)Venkat Prasad
5)Himani Jerath

(57) Abstract :

An IoT system for saving electric power consumption based on timetable in each class room. The system ensures the security whilst there is no class scheduled during the hour for a said class room by locking it. The system captures the schedule dynamically on a customized frequency from the timetable and updates itself. The system also displays the details about the pre and post scheduled classes outside the class.

No. of Pages : 11 No. of Claims : 5

(12) PATENT APPLICATION PUBLICATION

(21) Application
No.201911049282 A

(19) INDIA

(22) Date of filing of Application :30/11/2019

(43) Publication Date :
20/12/2019

(54) Title of the invention : A SYSTEM FOR DETACHABLE PRESSURE BASED RO PURIFIER

(51)
International :A61B0017000000,C02F0001440000,H02J0003280000,C02F0001280000,C02F0001000000
classification
(31) Priority
Document :NA
No
(32) Priority :NA
Date
(33) Name
of priority :NA
country
(86)
International
Application :NA
No :NA
Filing
Date
(87)
International
Publication : NA
No
(61) Patent
of Addition
to
Application :NA
Number :NA
Filing
Date
(62)
Divisional to
Application :NA
Number :NA
Filing
Date

(71)**Name of Applicant :**
**1)Lovely Professional
University**
Address of Applicant
:Lovely Professional
University Jalandhar-
Delhi G.T. Road,
Phagwara, Punjab-144
411, India Punjab India
(72)**Name of Inventor :**
1)SINGH, Mandeep
**2)CHOUDHURY,
Ruhul Amin**

(57) Abstract :

Disclosed is a system for detachable pressure based RO purifier attachment for purifying the normal tap water without electricity supply. The present invention uses hydraulic mechanism for purifying the water and purified water stores in the container. The present invention works without electricity supply and easy to install with existing normal water tap.

No. of Pages : 11 No. of Claims : 6

(12) PATENT APPLICATION PUBLICATION

(21) Application
No.201911049283 A

(19) INDIA

(22) Date of filing of Application :30/11/2019

(43) Publication Date :
20/12/2019

(54) Title of the invention : IOT BASED BMR SCANNER FOR PHARMACEUTICAL INDUSTRY

(51)
International :H04L0029080000,G06K0009200000,G06K0009030000,A61K0036270000,B41J0029460000
classification
(31) Priority
Document :NA
No
(32) Priority :NA
Date
(33) Name
of priority :NA
country
(86)
International
Application :NA
No :NA
Filing
Date
(87)
International
Publication : NA
No
(61) Patent
of Addition
to
Application :NA
Number :NA
Filing
Date
(62)
Divisional to
Application :NA
Number :NA
Filing
Date

(71)**Name of Applicant**
:
**1)Lovely Professional
University**
Address of Applicant
:Lovely Professional
University Jalandhar-
Delhi G.T. Road,
Phagwara, Punjab-144
411, India Punjab India
(72)**Name of Inventor :**
1)RATHOUR, Navjot
2)GEHLOT, Anita
3)SINGH, Rajesh
4)GUPTA, Lovi Raj

(57) Abstract :

Disclosed is a system for scanning BMR (Batch Manufacturing Record) documents in pharmaceutical industry. The present invention uses hardware and software part in which the hardware part consists of a Raspberry-Pi, a buzzer, mouse, a keyboard, a screen, a camera, a neural compute stick, and the software part consists of a BMR capturing, a preprocessing, a OCR (optical character recognition), a excel storage, a threshold comparison and testing from prior sheets and an alert signal generation. The present invention converts the images of BMR document in excel file and compare the values with predefined data to generate an alarm. The present invention stores the data on cloud as the device is IoT enabled. The present invention reduces the error in the document before actually handed over the BMR document to the operator.

No. of Pages : 10 No. of Claims : 7

(12) PATENT APPLICATION PUBLICATION

(21) Application
No.201911049284 A

(19) INDIA

(22) Date of filing of Application :30/11/2019

(43) Publication Date :
20/12/2019

(54) Title of the invention : A SYSTEM TO FIND THE MISSING SHOE PAIR SHOE FRIEND

(51)
International :A43B0003000000,B22C0009220000,G08B0021240000,G01S0019240000,H02P0006160000
classification
(31) Priority
Document :NA
No
(32) Priority
Date :NA
(33) Name
of priority :NA
country
(86)
International
Application :NA
No :NA
Filing
Date
(87)
International
Publication : NA
No
(61) Patent
of Addition
to
Application :NA
Number :NA
Filing
Date
(62)
Divisional to
Application :NA
Number :NA
Filing
Date

(71)**Name of Applicant :**
**1)Lovely Professional
University**
Address of Applicant
:Lovely Professional
University Jalandhar-
Delhi G.T. Road,
Phagwara, Punjab-144
411, India Punjab India
(72)**Name of Inventor :**
1)GAIN, Saurabh
**2)BAGWARI,
Swapnil**
3)GEHLOT,Anita
4)SINGH, Rajesh

(57) Abstract :

A smart system to find the missing pair of the shoe, when they are placed away from each other the buzzer is triggered. A buzzer is triggered to indicate the missing shoe until placed next to each in a threshold level. This system is used to save time and re-solve the trouble of finding the missing shoe with easy

No. of Pages : 12 No. of Claims : 7

(12) PATENT APPLICATION PUBLICATION

(21) Application
No.201911049285 A

(19) INDIA

(22) Date of filing of Application :30/11/2019

(43) Publication Date :
20/12/2019

(54) Title of the invention : IOT ENABLED ROAD HEALTH CONDITION SUPERVISOR

(51)
International :E01F0015100000,H04W0004120000,G06F0016215000,C08G0018790000,G06N0020000000
classification
(31) Priority
Document :NA
No
(32) Priority :NA
Date
(33) Name
of priority :NA
country
(86)
International
Application :NA
No :NA
Filing
Date
(87)
International : NA
Publication
No
(61) Patent
of Addition
to
Application :NA
Number :NA
Filing
Date
(62)
Divisional to
Application :NA
Number :NA
Filing
Date

(71)**Name of Applicant**
:
**1)Lovely Professional
University**
Address of
Applicant :Lovely
Professional University
Jalandhar-Delhi G.T.
Road, Phagwara,
Punjab-144 411, India
Punjab India
(72)**Name of Inventor :**
1)SINGH, Rajesh
**2)KUMAR, Juluri
Bharath**
3)GEHLOT, Anita
**4)KALANGI, Jithin
Sri Sai**
**5)MEDISETTY,
Arun Sai Teja**

(57) Abstract :

Disclosed is a system to monitor the condition of road and upload the information to the cloud using LoRa module. The present invention works in two phases; in first phase, the device located in the vehicle reads the values of the vibration sensor and uploads it to the cloud using the LoRa module, and in second phase, the receiver wherein LoRa receiver receives information from transmitter and uploads to the cloud using Wi-Fi module. The present invention requires internet connectivity with each server for receiving data by server and on basis of received data, the quality of road detects with the help of SVM (Support Vector Machine) and generate report regarding the conditions of roads. The present invention reduces the overall cost for repairing of roads as well as provides safe journey for the passengers.

No. of Pages : 13 No. of Claims : 6

(12) PATENT APPLICATION PUBLICATION

(21) Application
No.201911049286 A

(19) INDIA

(22) Date of filing of Application :30/11/2019

(43) Publication Date :
20/12/2019

(54) Title of the invention : LOW SPEED FAN BASED SMOG SETTLER AND DISPERSERS

(51)
International :G01N0021530000,A24F0047000000,C07C0002620000,A61K0031498000,A63B0043000000
classification
(31) Priority
Document :NA
No
(32) Priority :NA
Date
(33) Name
of priority :NA
country
(86)
International
Application :NA
No :NA
Filing
Date
(87)
International : NA
Publication
No
(61) Patent
of Addition
to
Application :NA
Number :NA
Filing
Date
(62)
Divisional to
Application :NA
Number :NA
Filing
Date

(71)**Name of Applicant**
:
**1)Lovely Professional
University**
Address of Applicant
:Lovely Professional
University Jalandhar-
Delhi G.T. Road,
Phagwara, Punjab-144
411, India Punjab India
(72)**Name of Inventor :**
1)SINGH, Mandeep
2)CHOUDHURY,
Ruhul Amin
3)GUPTA, Lovi Raj

(57) Abstract :

Disclosed is a system for smog settler and disperser which removes the smog and increases the visibility on the roads and provide convenience for driving. The present invention consists of fan flaps/fins, low speed motor and cotton spikes and wrinkles to collect smog. The present invention minimizes the accidents by improving the visibility during smog.

No. of Pages : 12 No. of Claims : 6

(12) PATENT APPLICATION PUBLICATION

(21) Application
No.201911049288 A

(19) INDIA

(22) Date of filing of Application :30/11/2019

(43) Publication Date :
20/12/2019

(54) Title of the invention : A NOVEL ANTI-FUNGAL FORMULATION FOR COTTON CROP AND METHOD THEREOF

(51)
International :A23B0007155000,C05F0011080000,C12P0007100000,A01N0065000000,A01N0063040000
classification
(31) Priority
Document :NA
No
(32) Priority :NA
Date
(33) Name
of priority :NA
country
(86)
International
Application :NA
No :NA
Filing
Date
(87)
International
Publication : NA
No
(61) Patent
of Addition
to
Application :NA
Number :NA
Filing
Date
(62)
Divisional to
Application :NA
Number :NA
Filing
Date

(71)**Name of Applicant**
:
**1)Lovely Professional
University**
Address of Applicant
:Lovely Professional
University, Jalandhar-
Delhi GT road
Phagwara- 144411.
Punjab India
(72)**Name of Inventor :**
1)Ashish Vyas
2)Kamaldeep Kaur

(57) Abstract :

The present invention discloses a biochemical anti-fungal formulation. The anti-fungal formulation consists of medicinal plants, antagonistic fungal strains and endophytic bacteria. The formulation protects the agricultural environment and biological resources through sustainable uses.

No. of Pages : 9 No. of Claims : 5

(12) PATENT APPLICATION PUBLICATION

(21) Application
No.201911049289 A

(19) INDIA

(22) Date of filing of Application :30/11/2019

(43) Publication Date :
20/12/2019

(54) Title of the invention : A NOVEL MULTIMEDIA MOBILE CHATBOT SYSTEM

(51)
International :H04L0029080000,A61B0017170000,F01D0005000000,A63F0013000000,H04N0021854700
classification
(31) Priority
Document :NA
No
(32) Priority :NA
Date
(33) Name
of priority :NA
country
(86)
International
Application :NA
No :NA
Filing
Date
(87)
International
Publication : NA
No
(61) Patent
of Addition
to
Application :NA
Number :NA
Filing
Date
(62)
Divisional to
Application :NA
Number :NA
Filing
Date

(71)**Name of Applicant**
:
**1)Lovely Professional
University**
Address of Applicant
:Lovely Professional
University, Jalandhar-
Delhi GT road
Phagwara- 144411.
Punjab India
(72)**Name of Inventor :**
1)Anita Gehlot
2)Rajesh Singh
3)Paramveer Kang
4)Prabin Kumar Das
**5)Vinay Kumar
Reddy Komma**

(57) Abstract :

The present invention discloses a novel multimedia mobile chatbot system. The system consists of mobility wheels (106), camera (104), computing unit 2 (102), computing unit 1 (101), IoT cloud server and API, speaker (103), trained database (108) and GUI screen. The system is used for guiding the visitors and guest with various interactive and pathway guidance capability.

No. of Pages : 15 No. of Claims : 7

(12) PATENT APPLICATION PUBLICATION

(21) Application
No.201911049290 A

(19) INDIA

(22) Date of filing of Application :30/11/2019

(43) Publication Date :
20/12/2019

(54) Title of the invention : A SMART CAR LIFTING SYSTEM

(51)
International :B60C0023040000,B60C0023080000,G01L0017000000,B60C0029060000,B64C0013000000
classification
(31) Priority
Document :NA
No
(32) Priority :NA
Date
(33) Name
of priority :NA
country
(86)
International
Application :NA
No :NA
Filing
Date
(87)
International
Publication : NA
No
(61) Patent
of Addition
to
Application :NA
Number :NA
Filing
Date
(62)
Divisional to
Application :NA
Number :NA
Filing
Date

(71)**Name of Applicant :**
**1)Lovely Professional
University**
Address of Applicant
:Lovely Professional
University, Jalandhar-
Delhi GT road
Phagwara- 144411.
Punjab India
(72)**Name of Inventor :**
1)Satnam Singh
2)Chetan Krishna
3)Jaiinder Pal Singh
4)Piyush Gulati
5)Manpreet Singh
6)Mohit Jain
7)Yash Nath Shahdeo

(57) Abstract :

The present invention discloses a novel system to lift car. The smart car liftingsystem consists of vehicle chassis (5), jacks, tyre pressure monitoring system (1),tyre pressure monitoring system display (7), a joystick, electric motors, controlsfor the jacks and ground support (10). The driver can check which tyre gotpunctured or which tyre is having low air pressure while sitting in the car duringdriving. The system automatically lift the car from both ends

No. of Pages : 12 No. of Claims : 3

(12) PATENT APPLICATION PUBLICATION

(21) Application
No.201911049291 A

(19) INDIA

(22) Date of filing of Application :30/11/2019

(43) Publication Date :
20/12/2019

(54) Title of the invention : A SELF-STERILIZING MICRO-PIPETTE

(51)
International :B01L0003020000,G01N0035100000,H05K0005000000,H02J0007000000,A47B0065000000
classification

(31) Priority
Document :NA
No

(32) Priority
Date :NA

(33) Name
of priority :NA
country

(86)
International
Application :NA
No :NA

Filing
Date

(87)
International
Publication : NA
No

(61) Patent
of Addition
to
Application :NA
Number :NA

Filing
Date

(62)
Divisional to
Application :NA
Number :NA

Filing
Date

(71)**Name of Applicant :**
**1)Lovely Professional
University**

Address of Applicant
:Lovely Professional
University, Jalandhar-
Delhi GT road
Phagwara- 144411.
Punjab India

(72)**Name of Inventor :**
1)Reena Singh
2)Chirag Chopra

(57) Abstract :

The present invention discloses a self-sterilizing micro-pipette. The micro-pipette(100) consists of a micro-pipette assembly, electronic control unit (103), a UV-proof cap (104), and a charging point (105).

No. of Pages : 15 No. of Claims : 7

(12) PATENT APPLICATION PUBLICATION

(21) Application
No.201911049293 A

(19) INDIA

(22) Date of filing of Application :30/11/2019

(43) Publication Date :
20/12/2019

(54) Title of the invention : A NOVEL FOLDABLE COMPACT FLOWER POT

(51)
International :A47B0043000000,B30B0009300000,B65B0063020000,A23L0029212000,A01G0009020000
classification
(31) Priority
Document :NA
No
(32) Priority :NA
Date
(33) Name
of priority :NA
country
(86)
International
Application :NA
No :NA
Filing
Date
(87)
International
Publication : NA
No
(61) Patent
of Addition
to
Application :NA
Number :NA
Filing
Date
(62)
Divisional to
Application :NA
Number :NA
Filing
Date

(71)**Name of Applicant**
:
**1)Lovely Professional
University**
Address of Applicant
:Lovely Professional
University, Jalandhar-
Delhi GT road
Phagwara- 144411.
Punjab India
(72)**Name of Inventor :**
1)Akash Pandey
2)Sunpreet Singh
3)Chander Prakash

(57) Abstract :

The present invention discloses a novel foldable and compact flower pot. The foldable flower pot consists of a bottom portion, a side wall portion. The sidewalls can be folded vertically down to provide a partially compacted form (2) and a fully compacted form (1). The pot can be transported from one place to another by just keeping it into a bag by an individual.

No. of Pages : 16 No. of Claims : 4

(12) PATENT APPLICATION PUBLICATION

(21) Application
No.201911049294 A

(19) INDIA

(22) Date of filing of Application :30/11/2019

(43) Publication Date :
20/12/2019

(54) Title of the invention : A SMART PORTABLE RICE GRADING DEVICE

(51)
International :H01L0023000000,H02J0001080000,G01J0003020000,G10L0017220000,H04W0036040000
classification

(31) Priority
Document :NA
No

(32) Priority
Date :NA

(33) Name
of priority :NA
country

(86)
International
Application :NA
No :NA

Filing
Date

(87)
International
Publication : NA
No

(61) Patent
of Addition
to
Application :NA
Number :NA

Filing
Date

(62)
Divisional to
Application :NA
Number :NA

Filing
Date

(71)**Name of Applicant :**
**1)Lovely Professional
University**

Address of Applicant
:Lovely Professional
University, Jalandhar-
Delhi GT road Phagwara-
144411. Punjab India

(72)**Name of Inventor :**
1)Bhupinder Verma
**2)Mahesh Kumar
Prajapat**
3)Rajesh Singh
4)Anita Gehlot
5)Lovi Raj Gupta

(57) Abstract :

The present invention discloses a smart and portable rice grading device. The device consists of a camera, a tensor processing system, a micro mouse, a microkeyboard, a rice handle, a battery and a Raspberry pi. The device is low cost and easy to maintain. The device is able to quickly grade rice based on Government Index.

No. of Pages : 15 No. of Claims : 9

(12) PATENT APPLICATION PUBLICATION

(21) Application
No.201911049321 A

(19) INDIA

(22) Date of filing of Application :30/11/2019

(43) Publication Date :
20/12/2019

(54) Title of the invention : A NOVEL COMPOSITION AND PROCESS FOR POT PREPARATION

(51)
International :H01M0010052500,A21D0013060000,A01N0037460000,A01N0025220000,A61K0009510000
classification

(31) Priority
Document :NA
No

(32) Priority
Date :NA

(33) Name
of priority :NA
country

(86)
International
Application :NA
No :NA

Filing
Date

(87)
International
Publication : NA
No

(61) Patent
of Addition
to
Application :NA
Number :NA

Filing
Date

(62)
Divisional to
Application :NA
Number :NA

Filing
Date

(71)**Name of Applicant :**
1)Lovely Professional University
Address of Applicant :Lovely Professional University, Jalandhar-Delhi GT road Phagwara- 144411. Punjab India

(72)**Name of Inventor :**
1)Suman Maji

(57) Abstract :

The present invention discloses a novel composite based plantation pot and process of preparation thereof. The novel composition consists of composite which are fortified with nanoparticle. The concentration of nanoparticles is optimized so that there is no toxic effect of the elements. The nanoparticles leach very slow in to soil so that the availability can be maintained for a long time providing a sustainable growth of the plants in the enriched pots.

No. of Pages : 13 No. of Claims : 7

(12) PATENT APPLICATION PUBLICATION

(21) Application
No.201911049322 A

(19) INDIA

(22) Date of filing of Application :30/11/2019

(43) Publication Date :
20/12/2019

(54) Title of the invention : A NOVEL PLANTING POT

(51)
International :A01G0009020000,B07B0013020000,A01G0027020000,G03F0007180000,A01G0027040000
classification
(31) Priority
Document :NA
No
(32) Priority :NA
Date
(33) Name
of priority :NA
country
(86)
International
Application :NA
No :NA
Filing
Date
(87)
International
Publication : NA
No
(61) Patent
of Addition
to
Application :NA
Number :NA
Filing
Date
(62)
Divisional to
Application :NA
Number :NA
Filing
Date

(71)**Name of Applicant**
:
**1)Lovely Professional
University**
Address of
Applicant :Lovely
Professional University,
Jalandhar-Delhi GT road
Phagwara- 144411.
Punjab India
(72)**Name of Inventor :**
**1)Chandra Mohan
Mehta**
2)Rasane Prasad
3)Sharad Sachan

(57) Abstract :

The present invention discloses a novel planting pot. The pot consists of inner layer, outer layer, holes in the inner layer, hollow cylinder placed at base of the pot, and water inlet. The pot helps to distribute water uniformly to the soil. The pot helps to avoid top soil displacement while watering.

No. of Pages : 12 No. of Claims : 5

(12) PATENT APPLICATION PUBLICATION

(21) Application
No.201911049323 A

(19) INDIA

(22) Date of filing of Application :30/11/2019

(43) Publication Date :
20/12/2019

(54) Title of the invention : AN AUTOMATIC SYSTEM FOR ANALYZING UNDERWATER ENVIRONMENT

(51)
International :B32B0027320000,G02F0001133700,B32B0027080000,G01S0015890000,G06F0009445000
classification

(31) Priority
Document :NA
No

(32) Priority
Date :NA

(33) Name
of priority :NA
country

(86)
International
Application :NA
No :NA

Filing
Date

(87)
International
Publication : NA
No

(61) Patent
of Addition
to
Application :NA
Number :NA

Filing
Date

(62)
Divisional to
Application :NA
Number :NA

Filing
Date

(71)**Name of Applicant :**
**1)Lovely Professional
University**

Address of Applicant
:Lovely Professional
University, Delhi
Jalandhar GT road
Phagwara- 144411.
Punjab India

(72)**Name of Inventor :**
**1)Dushyant Kumar
Singh**

2)Kanwaljeet Singh

3)P Raja

4)Shivang Tyagi

(57) Abstract :

Disclosed is an automatic system controls the electrical and electro-mechanical appliances of a security, animal investigation along with data storage in Raspberry Pi. The present invention detects and classifies the specific object as well as store the new data about the new object. The present invention automatically analyze underwater environment and find applications in military and rescue operations.

No. of Pages : 12 No. of Claims : 6

(12) PATENT APPLICATION PUBLICATION

(21) Application
No.201911049325 A

(19) INDIA

(22) Date of filing of Application :30/11/2019

(43) Publication Date :
20/12/2019

(54) Title of the invention : A NOVEL SYSTEM FOR FOOD PACKAGING

(51)
International :G06Q0030060000,A23P0030100000,G06K0009620000,A23L0019000000,A23L0019180000
classification
(31) Priority
Document :NA
No
(32) Priority
Date :NA
(33) Name
of priority :NA
country
(86)
International
Application :NA
No :NA
Filing
Date
(87)
International
Publication : NA
No
(61) Patent
of Addition
to
Application :NA
Number :NA
Filing
Date
(62)
Divisional to
Application :NA
Number :NA
Filing
Date

(71)**Name of Applicant**
:
**1)Lovely professional
University**
Address of Applicant
:Lovely Professional
University, Jalandhar-
Delhi GT road
Phagwara- 144411
Punjab India
(72)**Name of Inventor :**
1)Dr. Prasad Rasanae
**2)Dr. Chandra
Mohan Mehta**
3)Ms Jyoti Singh
4)Dr. Sawinder Kaur

(57) Abstract :

A packaging system for food products which can be used on any type of food product especially fruits and vegetables. The system is a three layered system and layers can further be increased based on food type.

No. of Pages : 12 No. of Claims : 5

(12) PATENT APPLICATION PUBLICATION

(21) Application
No.201911049326 A

(19) INDIA

(22) Date of filing of Application :30/11/2019

(43) Publication Date :
20/12/2019

(54) Title of the invention : A SYSTEM FOR AN AUTONOMOUS SHOPPING CART

(51)
International :G06Q0030060000,H04N0005357000,B62B0003140000,G01N0021950000,G07F0007020000
classification

(31) Priority
Document :NA
No

(32) Priority
Date :NA

(33) Name
of priority :NA
country

(86)
International
Application :NA
No :NA

Filing
Date

(87)
International
Publication : NA
No

(61) Patent
of Addition
to

Application :NA
Number :NA

Filing
Date

(62)
Divisional to
Application :NA

Number :NA

Filing
Date

(71)**Name of Applicant**
:
**1)Lovely Professional
University**

Address of
Applicant :Lovely
Professional University,
Delhi Jalandhar GT road
Phagwara- 144411.
Punjab India

(72)**Name of Inventor :**
1)Ruhul Amin

Choudhury

2)Mandeep Singh

3)Ashish Jangra

4)Anant Kumar

Rajput

(57) Abstract :

Disclosed is a system for an autonomous shopping cart which consists of a Heat Sealer, a Cutter, a Table, a Camera module, a Scan station, a Packaging Dispensing roller, an Openable door, a plurality of wheels, and a Controlling unit. The present invention activates the auto packaging system which packs the all items within the size of load quantity. The present invention also facilitates an indication light and an automatic wheels locking system for the security purpose and provides information whether payment of purchased items is completed or not. The present invention provides secure and hassle free shopping for shoppers.

No. of Pages : 13 No. of Claims : 8

(12) PATENT APPLICATION PUBLICATION

(21) Application
No.201911049327 A

(19) INDIA

(22) Date of filing of Application :30/11/2019

(43) Publication Date :
20/12/2019

(54) Title of the invention : A METHOD AND DEVICE TO PREDICT CRIMINAL INTENTION

(51)
International :G08B0013196000,G06N0007000000,G06Q0050260000,F41A0017060000,G08B0015000000
classification
(31) Priority
Document :NA
No
(32) Priority :NA
Date
(33) Name
of priority :NA
country
(86)
International
Application :NA
No :NA
Filing
Date
(87)
International : NA
Publication
No
(61) Patent
of Addition
to
Application :NA
Number :NA
Filing
Date
(62)
Divisional to
Application :NA
Number :NA
Filing
Date

(71)**Name of Applicant**
:
**1)Lovely Professional
University**
Address of
Applicant :Lovely
Professional University,
Delhi Jalandhar GT road
Phagwara- 144411.
Punjab India
(72)**Name of Inventor :**
1)Rajesh Singh
2)Anita Gehlot
3)Navjot Rathour
4)Prabin Kumar Das
5)Bishwajyoti Roy
6)Km Vaishnavi
Gupta
7)Vaseem Shaik
Akram
8)MD Mazharul
Islam Miraz

(57) Abstract :

Disclosed is a method and device to predict criminal intention and helps the security officers to identify the level of threat. The present invention consists of an end node to deploy over various places around the city, and an end node wherein consists of a computing unit which receives information from a camera and compares with pre-trained database to detect whether received information matches with previous information or not and stores that information to the storage device; and a transmitter connects with long range RF module and internet for sharing real time information with the central surveillance unit for monitoring. The present invention uses an IoT server at central surveillance node to store data for further training and analysis and prevent human trafficking and other crimes.

No. of Pages : 20 No. of Claims : 7

(12) PATENT APPLICATION PUBLICATION

(21) Application
No.201911049328 A

(19) INDIA

(22) Date of filing of Application :30/11/2019

(43) Publication Date :
20/12/2019

(54) Title of the invention : A SYSTEM FOR ELECTRONIC AUTHENTICATION FOR DOOR OPENING

(51)
International :H04W0048100000,G06Q0020400000,H04L0001180000,B60R0025040000,G06F0021520000
classification
(31) Priority
Document :NA
No
(32) Priority
Date :NA
(33) Name
of priority :NA
country
(86)
International
Application :NA
No :NA
Filing
Date
(87)
International
Publication : NA
No
(61) Patent
of Addition
to
Application :NA
Number :NA
Filing
Date
(62)
Divisional to
Application :NA
Number :NA
Filing
Date

(71)Name of Applicant
:
**1)Lovely professional
University**
Address of
Applicant :Lovely
Professional University
Jalandhar Delhi GT road
Phagwara-144411
Punjab India
(72)Name of Inventor :
1)Gurjot Singh Gaba

(57) Abstract :

A system for electronic authentication for door opening for avoiding theft and burglary. The system is more advanced. The system has a five layer security which increases the complexity of the system making it more secure.

No. of Pages : 10 No. of Claims : 5

(12) PATENT APPLICATION PUBLICATION

(21) Application
No.201911049329 A

(19) INDIA

(22) Date of filing of Application :30/11/2019

(43) Publication Date :
20/12/2019

(54) Title of the invention : A NOVEL SYSTEM FOR HANGING OBJECTS

(51)
International :G06F0016230000,H04W0024040000,A23K0020147000,A42B0003120000,A47F0005000000
classification
(31) Priority
Document :NA
No
(32) Priority :NA
Date
(33) Name
of priority :NA
country
(86)
International
Application :NA
No :NA
Filing
Date
(87)
International
Publication : NA
No
(61) Patent
of Addition
to
Application :NA
Number :NA
Filing
Date
(62)
Divisional to
Application :NA
Number :NA
Filing
Date

(71)Name of Applicant
:
**1)Lovely
Professional University**
Address of
Applicant :Lovely
Professional University,
Jalandhar-Delhi GT
road Phagwara- 144411.
Punjab India
(72)Name of Inventor :
**1)Manpreet Singh
2)Piyush Gulati
3)Jaiinder Pal Singh**

(57) Abstract :

A novel system for hanging objects which contains a U hanger bracket (1), hook (2) and rubber padding (3). The system is more advanced and can be used for a longer time. The system also helps in adjustment of height.

No. of Pages : 10 No. of Claims : 5

(12) PATENT APPLICATION PUBLICATION

(21) Application
No.201911049332 A

(19) INDIA

(22) Date of filing of Application :30/11/2019

(43) Publication Date :
20/12/2019

(54) Title of the invention : INTELLIGENT EVACUATION SYSTEM

(51)
International :E04H0009020000,G01V0001000000,G16H0050200000,G06N0003000000,G16H0010600000
classification

(31) Priority
Document :NA
No

(32) Priority
Date :NA

(33) Name
of priority :NA
country

(86)
International
Application :NA
No :NA

Filing
Date

(87)
International
Publication : NA

No

(61) Patent
of Addition
to
Application :NA
Number :NA

Filing
Date

(62)
Divisional to

Application :NA
Number :NA

Filing
Date

(71)Name of Applicant
:

**1)Lovely
Professional
University**
Address of
Applicant :Lovely
Professional University
Delhi Jalandhar GT
Road Phagwara-144411
Punjab India

(72)Name of Inventor :

**1)Dr. Ashutosh
Sharma
2)Dr. Sakshi Aneja
3)Dr. Neeta Raj
Sharma
4)Mr. Yeluri Sessa
Choudary**

(57) Abstract :

An intelligent alarming system which works in areas where natural calamities occur at higher frequencies especially earthquakes. The system works on artificial intelligence.

No. of Pages : 12 No. of Claims : 5

(12) PATENT APPLICATION PUBLICATION

(21) Application
No.201911049333 A

(19) INDIA

(22) Date of filing of Application :30/11/2019

(43) Publication Date :
20/12/2019

(54) Title of the invention : A SMART SYSTEM TO ASSIST MOTHERS WITH THEIR INFANTS

(51)
International :A23L0033000000,A61B0005083000,A47D0009000000,G06Q0050060000,A61M0001100000
classification
(31) Priority
Document :NA
No
(32) Priority :NA
Date
(33) Name
of priority :NA
country
(86)
International
Application :NA
No :NA
Filing
Date
(87)
International : NA
Publication
No
(61) Patent
of Addition
to
Application :NA
Number :NA
Filing
Date
(62)
Divisional to
Application :NA
Number :NA
Filing
Date

(71)**Name of Applicant**
:
**1)Lovely
Professional
University**
Address of
Applicant :Lovely
Professional University
Delhi Jalandhar GT
Road Phagwara-144411
Punjab India
(72)**Name of Inventor**
:
**1)GURJOT SINGH
GABA**

(57) Abstract :

A smart system for assisting mothers with their infants. The system hereby recognizes the mothers and babies conversations while feeding and alerts about the next feeding schedule.

No. of Pages : 10 No. of Claims : 5

(12) PATENT APPLICATION PUBLICATION

(21) Application
No.201911049335 A

(19) INDIA

(22) Date of filing of Application :30/11/2019

(43) Publication Date :
20/12/2019

(54) Title of the invention : A NOVEL POLISHING PROCESS FOR NANO-FINISHING OF B-PHASE TI-35NB-7TA-5ZR BIOMEDICAL ALLOY

(51)
International :B24B0001000000,B24B0031000000,C08G0018100000,C09K0003140000,G05B0019409900
classification
(31) Priority
Document :NA
No
(32) Priority :NA
Date
(33) Name
of priority :NA
country
(86)
International
Application :NA
No :NA
Filing
Date
(87)
International : NA
Publication
No
(61) Patent
of Addition
to
Application :NA
Number :NA
Filing
Date
(62)
Divisional to
Application :NA
Number :NA
Filing
Date

(71)**Name of Applicant**
:
1)Lovely Professional University
Address of Applicant
:Lovely Professional
University Delhi
Jalandhar GT Road
Phagwara-144411
Punjab India
(72)**Name of Inventor :**
1)PRAKASH,
Chander
2)SINGH, Sunpreet

(57) Abstract :

A process of polishing diamond based magnetorheological fluid magnetic abrasive polishing also known as DMR-MAP is developed which provides the 5 axis movement of tool to move along the circular path with rotating workpiece in antilock wise direction of tool for nano-fmishing of P-Phase Ti-35Nb-7Ta-5Zr for biomedical applications. The diamond based magnetorheological (MR) fluid magnetic abrasive Polishing (DMR-MAP) process, consists of three steps which are MR-fluid preparation, magnetic tool preparation, and finishing the parts. The process is a very high precision nano-level polishing process and obtain a free form surface.

No. of Pages : 15 No. of Claims : 5

(12) PATENT APPLICATION PUBLICATION

(21) Application
No.201911049336 A

(19) INDIA

(22) Date of filing of Application :30/11/2019

(43) Publication Date :
20/12/2019

(54) Title of the invention : A NOVEL PROCESS OF MAKING ZINC OXIDE SILVER NANOPARTICLE

(51)
International :B22F0009240000,B22F0001000000,B82Y0030000000,C07C0059010000,A61K0008310000
classification
(31) Priority
Document :NA
No
(32) Priority :NA
Date
(33) Name
of priority :NA
country
(86)
International
Application :NA
No :NA
Filing
Date
(87)
International : NA
Publication
No
(61) Patent
of Addition
to
Application :NA
Number :NA
Filing
Date
(62)
Divisional to
Application :NA
Number :NA
Filing
Date

(71)**Name of Applicant :**
**1)Lovely Professional
University**
Address of Applicant
:Lovely Professional
University Delhi
Jalandhar GT Road
Phagwara-144411 Punjab
India
(72)**Name of Inventor :**
**1)Dr. CHANDAN
ADHIKARI**

(57) Abstract :

A novel process for synthesis of zinc oxide silver nanoparticles which is simple cost effective and easy to handle. The process is using green chemistry ie without any organic solvent.

No. of Pages : 11 No. of Claims : 6

(12) PATENT APPLICATION PUBLICATION

(21) Application
No.201911049337 A

(19) INDIA

(22) Date of filing of Application :30/11/2019

(43) Publication Date :
20/12/2019

(54) Title of the invention : A NOVEL SPOILER SYSTEM FOR GENERATING ELECTRICITY IN CARS

(51)
International :B62D0035000000,H02J0009060000,B60W0020000000,H01M0010120000,H01M0006040000
classification
(31) Priority
Document :NA
No
(32) Priority :NA
Date
(33) Name
of priority :NA
country
(86)
International
Application :NA
No :NA
Filing
Date
(87)
International : NA
Publication
No
(61) Patent
of Addition
to
Application :NA
Number :NA
Filing
Date
(62)
Divisional to
Application :NA
Number :NA
Filing
Date

(71)**Name of Applicant :**
1)Lovely Professional University
Address of Applicant :Lovely Professional University
Delhi Jalandhar GT Road Phagwara-144411
Punjab India
(72)**Name of Inventor :**
1)CHOPRA, Chirag
2)GUPTA, Lovi Raj
3)SAINI, Mandeep Singh
4)SINGH, Reena

(57) Abstract :

The novel system which is utilized for generating electricity in cars consists of a spoiler set-up. Here, the axial fans are connected to each other in parallel and the voltage output from all the axial fans is fed to a rectifier (104), which stabilizes the voltage and feeds the same to an auxiliary battery (102) for storage. The stored electricity is supplied to cabin lights (LEDs), the dashboard display of the car and the lights of the boot. This set-up helps in extending the life of the primary battery by powering an auxiliary battery for the described functions in the car.

No. of Pages : 16 No. of Claims : 8

(12) PATENT APPLICATION PUBLICATION

(21) Application
No.201911049339 A

(19) INDIA

(22) Date of filing of Application :30/11/2019

(43) Publication Date :
20/12/2019

(54) Title of the invention : A NOVEL SMART TRACKING DEVICE FOR HIGH ALTITUDE LOCATIONS

(51)
International :A61B0005145500,A61B0005000000,H04M0001020000,A61B0005145000,A61B0005020500
classification
(31) Priority
Document :NA
No
(32) Priority :NA
Date
(33) Name
of priority :NA
country
(86)
International
Application :NA
No :NA
Filing
Date
(87)
International
Publication : NA
No
(61) Patent
of Addition
to
Application :NA
Number :NA
Filing
Date
(62)
Divisional to
Application :NA
Number :NA
Filing
Date

(71)**Name of Applicant**
:
**1)Lovely
Professional
University**
Address of
Applicant :Lovely
Professional University
Delhi Jalandhar GT
Road Phagwara-144411
` Punjab India
(72)**Name of Inventor :**
**1)SINGH, Harjit
2)PRAKASH,
Chander
3)PRADHAN,
Swastik
4)SINGH, Rajesh**

(57) Abstract :

The novel smart device which is able to detect the vulnerabilities such as temperature, humidity, pressure, oxygen level in air, oxygen level in blood, altitude, Radio frequency, GPS, direction, heart beat rate and provide real time data for enhancing trekking experience. The present invention consists of a microcontroller, raspberry Pi module, thermal image sensing, GPS module, radio frequency module, pulse oximetry sensor, oxygen level sensor, a BME sensor, LCD screen with keypad, magnetic campus. The device is useful in danger and risk monitoring.

No. of Pages : 12 No. of Claims : 7

(12) PATENT APPLICATION PUBLICATION

(21) Application
No.201911049341 A

(19) INDIA

(22) Date of filing of Application :30/11/2019

(43) Publication Date :
20/12/2019

(54) Title of the invention : A NOVEL SYSTEM OF MONITORING OF LOW TENSION PILLAR FOR DISTRIBUTION TRANSFORMER

(51)
International :G08B0025000000,G01S0017020000,H04L0029080000,H05B0037020000,G11C0007060000
classification
(31) Priority
Document :NA
No
(32) Priority :NA
Date
(33) Name
of priority :NA
country
(86)
International
Application :NA
No :NA
Filing
Date
(87)
International : NA
Publication
No
(61) Patent
of Addition
to
Application :NA
Number :NA
Filing
Date
(62)
Divisional to
Application :NA
Number :NA
Filing
Date

(71)Name of Applicant
:
**1)Lovely Professional
University**
Address of Applicant
:Lovely Professional
University Delhi
Jalandhar GT Road
Phagwara-144411
Punjab India
(72)Name of Inventor :
**1)SINGH, Rajesh
2)GEHLOT, Anita
3)DAS, Prabin Das**

(57) Abstract :

The system of monitoring of low tension pillar using IoT (Internet of things) wherein the low tension (LT) pillars are equipped with phase detector and sensing circuitry for each individual phase in a defined manner. In the present invention, by sensing the phase data from each sensing unit circuitry is transferred into a computing controller unit, it is then shared to a gateway unit by using long range RF communication in real-time. After receipt of the data from each sensing end unit, gateway unit differentiate it into separate pre-defined channels and then, by using pre-installed GPRS module it lodges the data into a dedicated IoT cloud server for further analysis and data storage. This lodged data is then reflected onto a user Interface in an arranged and collective manner for the monitoring guards to analyse.

No. of Pages : 17 No. of Claims : 6

(12) PATENT APPLICATION PUBLICATION

(21) Application
No.201911049342 A

(19) INDIA

(22) Date of filing of Application :30/11/2019

(43) Publication Date :
20/12/2019

(54) Title of the invention : A NOVEL LINKAGE SYSTEM FOR CONVERTING A WHEEL CHAIR INTO STRETCHER

(51)
International :A61G0005100000,A61G0005120000,A61G0005000000,A61G0003060000,A61G0005040000
classification
(31) Priority
Document :NA
No
(32) Priority :NA
Date
(33) Name
of priority :NA
country
(86)
International
Application :NA
No :NA
Filing
Date
(87)
International : NA
Publication
No
(61) Patent
of Addition
to
Application :NA
Number :NA
Filing
Date
(62)
Divisional to
Application :NA
Number :NA
Filing
Date

(71)**Name of Applicant**
:
**1)Lovely
Professional
University**
Address of
Applicant :Lovely
Professional University
Delhi Jalandhar GT
Road Phagwara-144411
Punjab India
(72)**Name of Inventor**
:
**1)SINGH, Satnam
2)SHARMA, Ajay
3)SINGH,
JaiinderPreet
4)GULATI, Piyush
5)SINGH, Manpreet
6)JAIN, Mohit**

(57) Abstract :

A novel system which mainly contains mechanical linkage system designed to convert a wheel chair into stretcher. The system consists of a frame (body) (2), a footrest (1), an adjustor (5), wheels (6), an arm rest (4), a handle (7), a back rest (8). The mechanical linkages help to convert wheel chair into the stretcher and vice versa. The system is simple in construction and more reliable as compared to other systems of converting a wheel chair into stretcher.

No. of Pages : 13 No. of Claims : 6

(12) PATENT APPLICATION PUBLICATION

(21) Application
No.201911049343 A

(19) INDIA

(22) Date of filing of Application :30/11/2019

(43) Publication Date :
20/12/2019

(54) Title of the invention : A NOVEL METHOD FOR CLADDING POROUS LAYER USING FRICTION STIR TECHNOLOGY

(51)
International :B23K0020120000,B25H0003000000,A61F0002300000,G01N0019040000,A61F0002360000
classification
(31) Priority
Document :NA
No
(32) Priority
Date :NA
(33) Name
of priority :NA
country
(86)
International
Application :NA
No :NA
Filing
Date
(87)
International
Publication : NA
No
(61) Patent
of Addition
to
Application :NA
Number :NA
Filing
Date
(62)
Divisional to
Application :NA
Number :NA
Filing
Date

(71)**Name of Applicant**
:
**1)lovely professional
university**
Address of Applicant
:Lovely Professional
University Delhi
Jalandhar GT Road
Phagwara-144411
Punjab India
(72)**Name of Inventor :**
1)Chander Prakash
2)Sunnpreet Singh
**3)AmardeepSingh
Kang**

(57) Abstract :

A method of developing a friction stir tool (1) having multiple holes are designed and fabricated in friction stir tool (1) to provide the nano-filler supply in the form of slurry to deposit on the magnesium based work piece (2) surface. The method provides a strong metallurgical bonding and excellent bioactivity and is capable of producing porous and non-homogenous layer of micro and sub-micro scale thickness.

No. of Pages : 13 No. of Claims : 6

(12) PATENT APPLICATION PUBLICATION

(21) Application
No.201911049344 A

(19) INDIA

(22) Date of filing of Application :30/11/2019

(43) Publication Date :
20/12/2019

(54) Title of the invention : A NOVEL METHOD TO MAKE ANTI-BACTERIAL CLOTH

(51)
International :A61K0009140000,B82Y0005000000,C12Q0001180000,A01N0059160000,D06M0011830000
classification

(31) Priority
Document :NA
No

(32) Priority
Date :NA

(33) Name
of priority :NA
country

(86)
International
Application :NA
No :NA

Filing
Date

(87)
International
Publication : NA
No

(61) Patent
of Addition
to
Application :NA
Number :NA

Filing
Date

(62)
Divisional to
Application :NA
Number :NA

Filing
Date

(71)**Name of Applicant :**
1)Lovely Professional University
Address of Applicant :Lovely Professional University, Delhi Jalandhar GT road Phagwara-144411. Punjab India

(72)**Name of Inventor :**
1)Chandan Adhikari

(57) Abstract :

A novel method used for preparing an anti-bacterial dye to make clothing free from bacteria and fungus. In the present invention, Silver and Gold are the major antibacterial agents. The present invention discloses the simple and cost effective two step preparation of a dye formulation having antimicrobial and antifungal activities. The inventions also disclose the possibility of commercialization of the textile dye for fabric preparation which can be further used for the designing different types of dress. The present methods also talk about the prototype formulation of a fabric through a simple dip coating method. Overall it addresses the preparation of an antibacterial dress that can be worn by people to save their skin for bacterial infection.

No. of Pages : 17 No. of Claims : 5

(12) PATENT APPLICATION PUBLICATION

(21) Application
No.201911049348 A

(19) INDIA

(22) Date of filing of Application :30/11/2019

(43) Publication Date :
20/12/2019

(54) Title of the invention : HIGH BOIL AND HIGH RETORT HYBRID POLYURETHANE RESIN, PRINTING INK PREPARED THEREFROM, AND PRINTED SUBSTRATE

(51)
International :C08G0018420000,C08G0018400000,C09J0175060000,C08G0018480000,C09D0175060000
classification
(31) Priority
Document :NA
No
(32) Priority :NA
Date
(33) Name
of priority :NA
country
(86)
International
Application :NA
No :NA
Filing
Date
(87)
International : NA
Publication
No
(61) Patent
of Addition
to
Application :NA
Number :NA
Filing
Date
(62)
Divisional to
Application :NA
Number :NA
Filing
Date

(71)**Name of Applicant :**
**1)YANSEFU INKS
AND COATINGS
PRIVATE LIMITED**
Address of Applicant
:Attn: Mr. Neelakamal
Mohapatra (For Patent)
Yansefu Inks and
Coatings Private Ltd Plot
No.20, Sector-5, Growth
Centre, Bawal, Rewari-
123501, Haryana, India
Haryana India
(72)**Name of Inventor :**
**1)NEELAKAMAL
MOHAPATRA
2)JITENDRA
KUMAR SHARMA**

(57) Abstract :

The present invention provides a one-component, hybrid polyurethane resin binder suitable for formulating printing inks for high boil and high retort applications. The hybrid polyurethane comprises: a diisocyanate, two high molecular weight (HMW) polyester polyol resins, and a polyether polyol resin. The number average molecular weight of the HMW polyester polyol resin A is 2000 to 12000 daltons, the number average molecular weight of the HMW polyester polyol resin B is 2000 to 8000 daltons; and the number average molecular weight of the polyether polyol resin (C) is 500 to 2000 daltons.

No. of Pages : 27 No. of Claims : 11

(12) PATENT APPLICATION PUBLICATION

(21) Application
No.201911049349 A

(19) INDIA

(22) Date of filing of Application :30/11/2019

(43) Publication Date :
20/12/2019

(54) Title of the invention : HIGH OPACITY LAMINATION WHITE INK AND PRINTED SUBSTRATE

(51)
International :C09D0011102000,C08G0018080000,C08G0018120000,B32B0027080000,B32B0027100000
classification
(31) Priority
Document :NA
No
(32) Priority :NA
Date
(33) Name
of priority :NA
country
(86)
International
Application :NA
No :NA
Filing
Date
(87)
International
Publication : NA
No
(61) Patent
of Addition
to
Application :NA
Number :NA
Filing
Date
(62)
Divisional to
Application :NA
Number :NA
Filing
Date

(71)**Name of Applicant**
:
**1)YANSEFU INKS
AND COATINGS
PRIVATE LIMITED**
Address of Applicant
:Plot No.20, Sector-5,
Growth Centre, Bawal,
Rewari-123501,
Haryana, India Haryana
India
(72)**Name of Inventor** :
**1)NEELAKAMAL
MOHAPATRA
2)JITENDRA
KUMAR SHARMA**

(57) Abstract :

The present invention provides a high opacity polyurethane resin based white ink, where the polyurethane resins are produced by polymerisation of diisocyanates with polyols and followed by chain extension with a chain extender such as amines. The polyurethane resins provide high opacity white inks that maintain improved adhesive lamination bond strength to polymeric substrates such as metallised polyethylene terephthalate (Met-PET) substrate, corona treated polyethylene terephthalate (CT PET), good blocking resistance, quick drying, and good re-solubility characters in alcohol and ester solvents. The high opacity white inks are useful in flexographic and/or gravure printing processes for laminated packaging.

No. of Pages : 21 No. of Claims : 10

(12) PATENT APPLICATION PUBLICATION

(21) Application
No.201911049351 A

(19) INDIA

(22) Date of filing of Application :01/12/2019

(43) Publication Date :
20/12/2019

(54) Title of the invention : A SMART DISPOSING DEVICE FOR WASTE TO MONEY FRAMEWORK

(51)
International :G06Q0030020000,B65F0001000000,G06Q0020320000,B65F0001140000,B30B0009300000
classification
(31) Priority
Document :NA
No
(32) Priority :NA
Date
(33) Name
of priority :NA
country
(86)
International
Application :NA
No :NA
Filing
Date
(87)
International
Publication : NA
No
(61) Patent
of Addition
to
Application :NA
Number :NA
Filing
Date
(62)
Divisional to
Application :NA
Number :NA
Filing
Date

(71)**Name of Applicant :**
**1)Lovely Professional
University**
Address of Applicant
:Lovely Professional
University, Delhi
Jalandhar GT road
Phagwara- 144411.
Punjab India
(72)**Name of Inventor :**
1)Rajesh Singh
2)Anita Gehlot
3)Vaseem Shaik
Akram
4)Dharam Buddhi

(57) Abstract :

A smart disposing device for waste to money framework, where the garbage disposed to the respective disposal container, reward is credited to the user's account through mobile application. The system contain different bins such as food , paper, glass and plastic waste, the respective waste product need to be disposed in the compartment and the weight of the waste is measured and credit to the user's account in the mobile application through wireless communication. This system helps to collect the waste being disposed through public transport and provides a clean environment.

No. of Pages : 17 No. of Claims : 6

(12) PATENT APPLICATION PUBLICATION

(21) Application
No.201911049352 A

(19) INDIA

(22) Date of filing of Application :01/12/2019

(43) Publication Date :
20/12/2019

(54) Title of the invention : CLOUD BASED VOICE ASSISTED INTELLIGENT BIN

(51)
International :H04L0029080000,H04W0004020000,G06F0003160000,B65F0001140000,A61M0005142000
classification

(31) Priority
Document :NA
No

(32) Priority
Date :NA

(33) Name
of priority :NA
country

(86)
International
Application :NA
No :NA

Filing
Date

(87)
International
Publication : NA
No

(61) Patent
of Addition
to
Application :NA
Number :NA

Filing
Date

(62)
Divisional to
Application :NA
Number :NA
Filing
Date

(71)Name of Applicant
:

**1)Lovely
Professional
University**
Address of
Applicant :Lovely
Professional University,
Delhi Jalandhar GT
road Phagwara- 144411.
Punjab India

(72)Name of Inventor :

**1)Lovi Raj Gupta
2)Rajesh Singh
3)Anita Gehlot
4)Shaik Vaseem
Akram**

(57) Abstract :

Disclosed is a cloud based voice assisted intelligent bin which consists of a voice command module; a lid module; a driving motor module; a guidance module; a level measurement module; a display unit; a RF communication; a controller unit; and a power supply. The present invention initiates work when receives voice command through wireless communication and reaches the specific location with assistance of offline geo mapping, and after reaching the destination, the lid of the intelligent bin opens and closes through voice command, and the vehicle disposes the trash at collection point; and the complete system monitors and analyzes through cloud server. The present invention helps to maintain hygienic environment in the office environment as well as it is battery operated.

No. of Pages : 28 No. of Claims : 7

(12) PATENT APPLICATION PUBLICATION

(21) Application
No.201911049354 A

(19) INDIA

(22) Date of filing of Application :01/12/2019

(43) Publication Date :
20/12/2019

(54) Title of the invention : AN IOT AND LORA FRAMEWORK FOR SUGARCANE CROP DISEASE DETECTION USING MACHINE VISION

(51)
International :H04L0029080000,G06F0021550000,G06T0007110000,G08B0021180000,G06Q0050220000
classification

(31) Priority
Document :NA
No

(32) Priority :NA
Date

(33) Name
of priority :NA
country

(86)
International
Application :NA
No :NA

Filing
Date

(87)
International : NA
Publication
No

(61) Patent
of Addition
to
Application :NA
Number :NA

Filing
Date

(62)
Divisional to
Application :NA
Number :NA

Filing
Date

(71)**Name of Applicant**
:
**1)Lovely Professional
University**

Address of Applicant
:Lovely Professional
University, Delhi
Jalandhar GT road
Phagwara- 144411.
Punjab India

(72)**Name of Inventor :**
**1)Chaikam Dinesh
Reddy**

2)Swapnil Bagwari

3)Anita Gehlot

4)Rajesh Singh

5)Dharam Buddhi

6)Kamal Kumar

Sharma

(57) Abstract :

A system which able to monitor the field and analyze the condition of the sugarcane crop and alert is sent to the user if any disease is detected in the sugarcane crop to take necessary action. The system used Agribot, which moves around the field and capture the images at regular intervals and uses Machine to Machine communication.

No. of Pages : 15 No. of Claims : 7

(12) PATENT APPLICATION PUBLICATION

(21) Application
No.201911049355 A

(19) INDIA

(22) Date of filing of Application :01/12/2019

(43) Publication Date :
20/12/2019

(54) Title of the invention : A NOVEL SYSTEM TO TRACK THE RAW MATERIAL AND FOOD SAFETY

(51)
International :A23L0033180000,A01D0041127000,G06Q0010060000,A23L0029300000,H04W0024000000
classification
(31) Priority
Document :NA
No
(32) Priority :NA
Date
(33) Name
of priority :NA
country
(86)
International
Application :NA
No :NA
Filing
Date
(87)
International : NA
Publication
No
(61) Patent
of Addition
to
Application :NA
Number :NA
Filing
Date
(62)
Divisional to
Application :NA
Number :NA
Filing
Date

(71)**Name of Applicant**
:
**1)Lovely
Professional
University**
Address of
Applicant :Lovely
Professional University,
Delhi Jalandhar GT
road Phagwara-
144411. Punjab India
(72)**Name of Inventor**
:
1)Rajan Miglani

(57) Abstract :

A system to track the crop production and ensure the safety of the food until it has been processed by the food factories /hotels/etc.The system tracks the crop from purchase of the seeds to the data collected until the harvest which includes the information about the entire crop production details. The sensor tags are used to gather the information of the seeds until the crop has been processed to edible food to assure its quality and prevent any substandard in the raw material.

No. of Pages : 13 No. of Claims : 7

(12) PATENT APPLICATION PUBLICATION

(21) Application
No.201911049363 A

(19) INDIA

(22) Date of filing of Application :02/12/2019

(43) Publication Date :
20/12/2019

(54) Title of the invention : MULTIFUNCTIONAL BOX

(51)
International :A01K0005010000,F25D0003080000,H04W0084180000,F25D0023120000,E01B0029100000
classification
(31) Priority
Document :NA
No
(32) Priority :NA
Date
(33) Name
of priority :NA
country
(86)
International
Application :NA
No :NA
Filing
Date
(87)
International : NA
Publication
No
(61) Patent
of Addition
to
Application :NA
Number :NA
Filing
Date
(62)
Divisional to
Application :NA
Number :NA
Filing
Date

(71)**Name of Applicant**
:
**1)Lovely Professional
University**
Address of
Applicant :Lovely
Professional University
Jalandhar-Delhi G.T.
Road, Phagwara,
Punjab-144 411, India
Punjab India
(72)**Name of Inventor :**
**1)Dr. CHERRY
BHARGAV**
2)SALMAN KHAN

(57) Abstract :

A multifunctional box which has plurality of compartments for keeping food, water, an IR based sanitizer, Bluetooth enabled speaker system. The box can be used for various recreational and professional activities.

No. of Pages : 12 No. of Claims : 5

(12) PATENT APPLICATION PUBLICATION

(21) Application
No.201911049364 A

(19) INDIA

(22) Date of filing of Application :02/12/2019

(43) Publication Date :
20/12/2019

(54) Title of the invention : A SYSTEM TO IMPROVE CUSTOMER SATISFACTION BASED ON SENTIMENTAL ANALYSIS

(51)
International :G06Q0050120000,G06Q0030020000,G06Q0030000000,H04R0001100000,G06Q0020320000
classification

(31) Priority
Document :NA
No

(32) Priority
Date :NA

(33) Name
of priority :NA
country

(86)
International
Application :NA
No :NA

Filing
Date

(87)
International
Publication : NA
No

(61) Patent
of Addition
to
Application :NA
Number :NA

Filing
Date

(62)
Divisional to
Application :NA
Number :NA

Filing
Date

(71)Name of Applicant
:

**1)Lovely
Professional
University**
Address of
Applicant :Lovely
Professional University
Jalandhar-Delhi G.T.
Road, Phagwara,
Punjab-144 411, India
Punjab India

(72)Name of Inventor :

**1)DAS, Prabin
Kumar
2)ROY, Bishwajyoti
3)GUPTA, Km
Vaishnavi
4)MIRAJ, MD
Mazharul Islam
5)RATHOUR,
Navjot
6)SINGH, Rajesh
7)GEHLOT, Anita**

(57) Abstract :

The present invention discloses a novel system to improve customer satisfaction more particularly the system is based on sentimental analysis. The system to improve customer satisfaction and to provide better hospitality in restaurants consists of a dining unit, a reception unit and a speaker to interact with the customer. The sentimental analysis is carried out by facial landmarks or emotion analysis from speech of the customer. User of the system needs no technical knowledge to operate the system.

No. of Pages : 17 No. of Claims : 9

(12) PATENT APPLICATION PUBLICATION

(21) Application
No.201911049365 A

(19) INDIA

(22) Date of filing of Application :02/12/2019

(43) Publication Date :
20/12/2019

(54) Title of the invention : A SYSTEM FOR AUTOMATIC PASSENGER LOAD SENSING IN PUBLIC TRANSPORT

(51)
International :G08G0001123000,G08G0001133000,G08G0001010000,B62D0047020000,B66B0001240000
classification
(31) Priority
Document :NA
No
(32) Priority :NA
Date
(33) Name
of priority :NA
country
(86)
International
Application :NA
No :NA
Filing
Date
(87)
International
Publication : NA
No
(61) Patent
of Addition
to
Application :NA
Number :NA
Filing
Date
(62)
Divisional to
Application :NA
Number :NA
Filing
Date

(71)Name of Applicant
:
**1)Lovely
Professional University**
Address of
Applicant :Lovely
Professional University
Jalandhar-Delhi G.T.
Road, Phagwara,
Punjab-144 411, India
Punjab India
(72)Name of Inventor :
**1)SHARMA , Kamal
Kumar
2)SINGH , Daljeet
3)SINGH , Rajesh
4)GEHLOT, Anita**

(57) Abstract :

A system using artificial intelligence for dynamic allocation of the buses and routes, where the system automatically calculates the number of passengers in the bus and senses the passenger congestion at each bus stop. The system also provides live information of the running buses in that particular route by collecting the live location of the bus. . The system may also cancel the route of that bus in which no passenger will be available or it may club the buses on neighboring routes to distribute the load efficiently or provide new bus to that particular route.

No. of Pages : 14 No. of Claims : 5

(12) PATENT APPLICATION PUBLICATION

(21) Application
No.201911049368 A

(19) INDIA

(22) Date of filing of Application :02/12/2019

(43) Publication Date :
20/12/2019

(54) Title of the invention : A SMART HEALTHCARE SYSTEM FOR PREGNANCY MANAGEMENT

(51)
International :A61B0005000000,G06Q0050220000,G01N0033680000,G16H0010600000,G16H0050200000
classification

(31) Priority
Document :NA
No

(32) Priority
Date :NA

(33) Name
of priority :NA
country

(86)
International
Application :NA
No :NA

Filing
Date

(87)
International
Publication : NA
No

(61) Patent
of Addition
to

Application :NA
Number :NA

Filing
Date

(62)
Divisional to
Application :NA

Number :NA
Filing
Date

(71)Name of Applicant
:

**1)Lovely
Professional
University**

Address of
Applicant :Lovely
Professional University
Jalandhar-Delhi G.T.
Road, Phagwara,
Punjab-144 411, India
Punjab India

(72)Name of Inventor :

**1)BERI, Rydhm
2)DUBEY, Mithilesh
Kumar
3)GEHLOT, Anita
4)SINGH, Rajesh**

(57) Abstract :

The present invention discloses a smart health care system for pregnant women. The smart healthcare system (99) for pregnancy consists of health care kit (100), fog node (101) and cloud server (103). The system record different health parameters of pregnant women. The system (99) captures health related data of pregnant woman and analyze crucial health parameters in real-time environment.

No. of Pages : 21 No. of Claims : 6

(12) PATENT APPLICATION PUBLICATION

(21) Application
No.201911049369 A

(19) INDIA

(22) Date of filing of Application :02/12/2019

(43) Publication Date :
20/12/2019

(54) Title of the invention : A NOVEL OBFUSCATED PROCESSOR ARCHITECTURE FOR HARDWARE SECURITY AND OPTIMIZATION

(51)
International :G06F0021140000,A61L0031140000,H04N0019600000,H04N0019169000,H04L0009000000
classification
(31) Priority
Document :NA
No
(32) Priority :NA
Date
(33) Name
of priority :NA
country
(86)
International
Application :NA
No :NA
Filing
Date
(87)
International :NA
Publication
No
(61) Patent
of Addition
to
Application :NA
Number :NA
Filing
Date
(62)
Divisional to
Application :NA
Number :NA
Filing
Date

(71)**Name of Applicant**
:
**1)Lovely Professional
University**
Address of Applicant
:Lovely Professional
University Jalandhar-
Delhi G.T. Road,
Phagwara, Punjab-144
411, India Punjab India
(72)**Name of Inventor :**
**1)PATHAK ,
Jyotirmoy**
**2)TRIPATHI, Suman
Lata**
3)KUMAR, Abhishek

(57) Abstract :

A novel system to provides a technological solution in order to improve the hardware security through mode based selection. Structural obfuscation of the Wallace Tree multiplier as well as Baugh Wooley multiplier is designed using Folding Technique of High Level Transformation technique. Structural Obfuscation is used to enhance the security of the system and optimizing the architecture, which prevents it from reverse engineering and side channel attack.

No. of Pages : 23 No. of Claims : 10

(12) PATENT APPLICATION PUBLICATION

(21) Application
No.201911049422 A

(19) INDIA

(22) Date of filing of Application :02/12/2019

(43) Publication Date :
20/12/2019

(54) Title of the invention : AUTOMATIC TEST DATA GENERATION FOR MACHINE LEARNING USING HYBRID GENETIC ALGORITHM

(51) International :G06N0003120000,G10L0015180000,G06F0011360000,H04L0029140000,G16H0050200000
classification

(31) Priority Document :NA
No

(32) Priority Date :NA

(33) Name of priority :NA
country

(86) International Application :NA
No :NA

Filing Date
(87)

International Publication : NA
No

(61) Patent of Addition to Application :NA
Number :NA

Filing Date
(62)

Divisional to Application :NA
Number :NA

Filing Date

(71)Name of Applicant :

1)Rijwan Khan
Address of Applicant
:Professor, Department
of computer science and
engineering, ABES
INSTITUTE OF
TECHNOLOGY,
GHAZIABAD, U.P.-
201009 Uttar Pradesh
India

**2)Akhilesh Kumar
Srivastava**

**3)Manish Mahajan
4)Satya Prakash**

Yadav
(72)Name of Inventor :

**1)Rijwan Khan
2)Akhilesh Kumar
Srivastava**

**3)Manish Mahajan
4)Satya Prakash**

Yadav

(57) Abstract :

An advanced automated test data generation approach utilizing hybrid genetic algorithm (GA) to produce test data that meets data flow and route selection requirements. To determine the automation of test data generation, the method applies dominance relationships among various nodes to dynamically allocate multi-objective fitness functions. The local/global hybrid search framework is used to choose the best systemic assessment for data values. Here, for the production and optimization of results, a method comprising hybrid genetic algorithm has been presented. This invention also introduces the outcomes of a series of evidence-based studies on a series of software programs, in contrast to the randomized test process, which determines the efficacy of our method. Ref. Fig 1 & Fig 2.

No. of Pages : 12 No. of Claims : 5

(12) PATENT APPLICATION PUBLICATION

(21) Application
No.201911049475 A

(19) INDIA

(22) Date of filing of Application :02/12/2019

(43) Publication Date :
20/12/2019

(54) Title of the invention : LORA & CLOUD SERVER BASED STRUCTURAL HEALTH MONITORING OF THE BRIDGE USING INTERNET OF THINGS

(51)
International :H04W0004020000,H04W0084120000,G16H0010600000,H04L0012640000,H04W0088160000
classification
(31) Priority
Document :NA
No
(32) Priority :NA
Date
(33) Name
of priority :NA
country
(86)
International
Application :NA
No :NA
Filing
Date
(87)
International : NA
Publication
No
(61) Patent
of Addition
to
Application :NA
Number :NA
Filing
Date
(62)
Divisional to
Application :NA
Number :NA
Filing
Date

(71)**Name of Applicant :**
1)Lovely Professional University
Address of Applicant :Lovely Professional University Jalandhar-Delhi G.T. Road, Phagwara, Punjab-144 411, India Punjab India
(72)**Name of Inventor :**
1)SINGH, Rajesh
2)GEHLOT, Anita
3)AKRAM, Shaik Vaseem

(57) Abstract :

A system used for real time monitoring of the health of bridge using internet of things. The system is the integration of wireless bridge health controller, a RF communication modem, a control unit, LoRa gateway and cloud server. While RF communication modem is embedded for receiving the sensory data from the wireless bridge controller, LoRa (Long Range) communication modem in control unit transmits the data to the gateway. The gateway is capable of receiving the data from the control unit and sending it to the cloud server through Wi-Fi modem. The graphical user interface on cloud server displays the status of health parameters with its location.

No. of Pages : 17 No. of Claims : 6

(12) PATENT APPLICATION PUBLICATION

(21) Application
No.201911049476 A

(19) INDIA

(22) Date of filing of Application :02/12/2019

(43) Publication Date :
20/12/2019

(54) Title of the invention : QUIZ GAME BUZZER SYSTEM USING INTERNET OF THINGS

<p>(51) International :G06Q0050100000,G06F0015020000,B66B0003000000,H04H0020610000,F25D0029000000 classification (31) Priority Document :NA No (32) Priority Date :NA (33) Name of priority :NA country (86) International Application :NA No :NA Filing Date (87) International Publication : NA No (61) Patent of Addition to Application :NA Number :NA Filing Date (62) Divisional to Application :NA Number :NA Filing Date</p>	<p>(71)Name of Applicant : 1)Lovely Professional University Address of Applicant :Lovely Professional University Jalandhar- Delhi G.T. Road, Phagwara, Punjab-144 411, India Punjab India (72)Name of Inventor : 1)SINGH, Rajesh 2)GEHLOT, Anita 3)AKRAM, Shaik Vaseem</p>
--	--

(57) Abstract :

An internet of things enabled buzzer system which decides the winner in quiz competition. The present invention consists of combination of 'N' number of customized quiz buzzers, a local server, a Wi-Fi and a result display unit .These customized quiz buzzers are connected to local server via Wi-Fi. The local server identifies the one who triggered the buzzer first. The necessary information like name of person who triggered the buzzer first is printed on the result display. The system enables real time monitoring of information for deciding the person who first presses the buzzer.

No. of Pages : 14 No. of Claims : 5

(12) PATENT APPLICATION PUBLICATION

(21) Application
No.201911049477 A

(19) INDIA

(22) Date of filing of Application :02/12/2019

(43) Publication Date :
20/12/2019

(54) Title of the invention : A METHOD TO ENHANCE SOLUBILITY OF NEVIRAPINE

(51)
International :A61K0009000000,A61K0031551000,A61K0031519000,B01F0001000000,A61K0009200000
classification
(31) Priority
Document :NA
No
(32) Priority :NA
Date
(33) Name
of priority :NA
country
(86)
International
Application :NA
No :NA
Filing
Date
(87)
International
Publication : NA
No
(61) Patent
of Addition
to
Application :NA
Number :NA
Filing
Date
(62)
Divisional to
Application :NA
Number :NA
Filing
Date

(71)**Name of Applicant**
:
**1)Lovely Professional
University**
Address of
Applicant :Lovely
Professional University
Jalandhar-Delhi G.T.
Road, Phagwara,
Punjab-144 411, India
Punjab India
(72)**Name of Inventor :**
1)WADHWA,
Pankaj
2)VARMA, Kalidindi
Dheeraj
3)MITTAL, Amit

(57) Abstract :

The present invention discloses a method to enhance solubility of nevirapine. The method consists of dissolving solid and liquid drug in a non-volatile solvent and then adding a carrier material to produce a wet mass which is then compressed. The method enhances dissolution rate of the nevirapine.

No. of Pages : 11 No. of Claims : 3

(12) PATENT APPLICATION PUBLICATION

(21) Application
No.201911049478 A

(19) INDIA

(22) Date of filing of Application :02/12/2019

(43) Publication Date :
20/12/2019

(54) Title of the invention : A NOVEL FORMULATION FOR ANTI-EPILEPTIC ACTIVITY

(51)
International :H01J0049140000,A61K0036580000,A61K0009140000,A61L0031040000,A61K0036185000
classification
(31) Priority
Document :NA
No
(32) Priority :NA
Date
(33) Name
of priority :NA
country
(86)
International
Application :NA
No :NA
Filing
Date
(87)
International
Publication : NA
No
(61) Patent
of Addition
to
Application :NA
Number :NA
Filing
Date
(62)
Divisional to
Application :NA
Number :NA
Filing
Date

(71)**Name of Applicant**
:
**1)Lovely Professional
University**
Address of Applicant
:Lovely Professional
University Jalandhar-
Delhi G.T. Road,
Phagwara, Punjab-144
411, India Punjab India
(72)**Name of Inventor :**
1)SHARMA,
Pushendra Kumar
2)SINGH, Vishaldeep
3)PANDEY, Prashant
Kumar
4)SHUKLA, Bishnu
Kant

(57) Abstract :

The present invention discloses a novel formulation for anti-epileptic activity. The novel formulation consists of standard yajna samigri, ammonium hydroxide and powdered yellow banana peels. The formulation is burnt with cow's desi ghee and fumes are inhaled for instant anti-epileptic activity.

No. of Pages : 8 No. of Claims : 3

(12) PATENT APPLICATION PUBLICATION

(21) Application
No.201911049479 A

(19) INDIA

(22) Date of filing of Application :02/12/2019

(43) Publication Date
: 20/12/2019

(54) Title of the invention : SMART IOT ENABLED DOORBELL SYSTEM

(51)
International :H04R0001020000,H04M0001020000,H04M0001040000,H04W0008000000,H04M0001725000
classification
(31) Priority
Document :NA
No
(32) Priority :NA
Date
(33) Name
of priority :NA
country
(86)
International
Application :NA
No :NA
Filing
Date
(87)
International : NA
Publication
No
(61) Patent
of Addition
to
Application :NA
Number :NA
Filing
Date
(62)
Divisional to
Application :NA
Number :NA
Filing
Date

(71)**Name of Applicant :**
1)Lovely Professional University
Address of Applicant :Lovely Professional University Jalandhar-Delhi G.T. Road, Phagwara, Punjab-144 411, India Punjab India
(72)**Name of Inventor :**
1)GUPTA, Lovi Raj
2)SINGH, Rajesh
3)GEHLOT, Anita
4)DAS, Prabin Kumar
5)ROY, Bishwajyoti
6)GUPTA, Km Vaishnavi

(57) Abstract :

Disclosed is a smart IoT enabled doorbell system which consists of a switch; a storage device; a computing unit; a speaker; a Wi-Fi module; a Bluetooth; a smartphone; an application; a synchronized loudspeaker; a music search engine; an application user interface wherein consists of a volume control; an alarm; a custom music. The present invention uses smartphone which is connected with the computing unit through the Wi-Fi and the low power Bluetooth module. The present invention facilitates music search engine to search music and after download in the storage device, user is able to set that music for doorbell music. The present invention further facilitates the user to access the device using internet of the smartphone from remote location.

No. of Pages : 16 No. of Claims : 7

(12) PATENT APPLICATION PUBLICATION

(21) Application
No.201911049480 A

(19) INDIA

(22) Date of filing of Application :02/12/2019

(43) Publication Date :
20/12/2019

(54) Title of the invention : AN INTELLIGENT DOG COLLAR TO DETECT AND INDICATE FEROCIOUSNESS OF A PET OR STRAY DOG

(51)
International :A01K0027000000,A01K0015020000,H04N0021422300,A01K0025000000,F02D0041280000
classification
(31) Priority
Document :NA
No
(32) Priority :NA
Date
(33) Name
of priority :NA
country
(86)
International
Application :NA
No :NA
Filing
Date
(87)
International : NA
Publication
No
(61) Patent
of Addition
to
Application :NA
Number :NA
Filing
Date
(62)
Divisional to
Application :NA
Number :NA
Filing
Date

(71)**Name of Applicant**
:
**1)Lovely
Professional University**
Address of
Applicant :Lovely
Professional University
Jalandhar-Delhi G.T.
Road, Phagwara,
Punjab-144 411, India
Punjab India
(72)**Name of Inventor :**
1)GUPTA, Lovi Raj
2)ANEJA, Sakshi
**3)SHARMA,
Ashutosh**
4)GEHLOT, Anita
**5)RATHOUR,
Navjot**
6)S, Arjun
**7)DAS, Prabin
Kumar**

(57) Abstract :

Disclosed is an intelligent dog collar to detect and indicate ferociousness of a pet or stray dog which consists of an electronic control unit wherein consists of a piezoelectric sensor, a computing unit, a LED (Light Emitting Diode), a microphone and a rechargeable/replaceable. The present invention uses mechanical vibrations that are produced on a piezoelectric sensor when dog barks, and is converted into electric energy, and after amplifying that signal stores in a database for further processing. The present invention records the repetitive barking sound of the dog and stores in a database and uses a machine learning algorithm to classify the different types of barking sounds and decides whether the dog is actually ferocious. The present invention provides information related to dog ferociousness using LED; a red LED glow on the dog collar which indicates to people that dog is ferocious; a green LED indicates that dog is not ferocious. The present invention detects as well as indicates dog ferociousness to provide safety to people from pet/stray dogs.

No. of Pages : 16 No. of Claims : 5

(12) PATENT APPLICATION PUBLICATION

(21) Application
No.201911049486 A

(19) INDIA

(22) Date of filing of Application :02/12/2019

(43) Publication Date :
20/12/2019

(54) Title of the invention : INTELLIGENT RAILWAY TRACK DETECTION SYSTEM USING FPGA

(51)
International :G08G0001160000,B61L0023040000,B61L0025020000,B61K0009100000,G06Q0040060000
classification
(31) Priority
Document :NA
No
(32) Priority :NA
Date
(33) Name
of priority :NA
country
(86)
International
Application :NA
No :NA
Filing
Date
(87)
International
Publication : NA
No
(61) Patent
of Addition
to
Application :NA
Number :NA
Filing
Date
(62)
Divisional to
Application :NA
Number :NA
Filing
Date

(71)**Name of Applicant**
:
**1)Lovely Professional
University**
Address of Applicant
:Lovely Professional
University Jalandhar-
Delhi G.T. Road,
Phagwara, Punjab-144
411, India Punjab India
(72)**Name of Inventor :**
**1)PATEL, Govind
Singh**
2)SINGH , Rajesh
3)GEHLOT , Anita
**4)TRIPATHI, Suma
Lata**

(57) Abstract :

An intelligent railway track detection system using FPGA to detect the faulty rail track and identify the cracks through FPGA processor in order to prevent accidents. The faulty line or crack alert is generated through Wi-Fi communication and communicated to the engine driver or a particular person to take the necessary action immediately to avoid accident or derailling of the train

No. of Pages : 16 No. of Claims : 7

(12) PATENT APPLICATION PUBLICATION

(21) Application
No.201911049487 A

(19) INDIA

(22) Date of filing of Application :02/12/2019

(43) Publication Date :
20/12/2019

(54) Title of the invention : A SMART TROLLEY BAG

(51)
International :G05D0001020000,H04W0004800000,A61H0003060000,B29C0065000000,G09B0009000000
classification

(31) Priority
Document :NA
No

(32) Priority
Date :NA

(33) Name
of priority :NA
country

(86)
International
Application :NA
No :NA

Filing
Date

(87)
International
Publication : NA
No

(61) Patent
of Addition
to
Application :NA
Number :NA

Filing
Date

(62)
Divisional to
Application :NA
Number :NA
Filing
Date

(71)**Name of Applicant :**
1)Lovely Professional University
Address of Applicant :Lovely Professional University
Jalandhar-Delhi G.T. Road, Phagwara, Punjab-144 411, India
Punjab India

(72)**Name of Inventor :**
1)TRIPATHI, Suman Lata
2)SAXENA, Sobhit
3)Patel, Govind Singh
4)Bhupendra, J
5)Rajesh, V
6)Sundeep, N
7)GEHLOT, Anita

(57) Abstract :

A smart trolley bag which functions fully autonomously by establishing a connection between it and the person operating it. The smart trolley consists of a Raspberry pi, ultrasonic sensors, IR sensors, a load Cell and sensor, motored wheels, and cloud server having connectivity with mobile application. In the present invention, a control unit is designed and fabricated that not only tracks the target but also moves towards it while doing the tracking by placing a unique handmade tag on the person operating it. The smart trolley is capable of human tracking, obstacle avoidance, maintaining a specific distance from the object.

No. of Pages : 15 No. of Claims : 6

(12) PATENT APPLICATION PUBLICATION

(21) Application
No.201911049488 A

(19) INDIA

(22) Date of filing of Application :02/12/2019

(43) Publication Date :
20/12/2019

(54) Title of the invention : DEEP LEARNING ASSISTED SYSTEM FOR TUTORING

(51)
International :G09B0019060000,G06N0020000000,G09B0007040000,G09B0007020000,G09B0005060000
classification
(31) Priority
Document :NA
No
(32) Priority
Date :NA
(33) Name
of priority :NA
country
(86)
International
Application :NA
No :NA
Filing
Date
(87)
International
Publication : NA
No
(61) Patent
of Addition
to
Application :NA
Number :NA
Filing
Date
(62)
Divisional to
Application :NA
Number :NA
Filing
Date

(71)**Name of Applicant**
:
**1)Lovely Professional
University,**
Address of
Applicant :Lovely
Professional University,
Delhi Jalandhar GT road
Phagwara- 144411.
Punjab India
(72)**Name of Inventor :**
1)SINGH, Rajesh
2)GEHLOT, Anita
3)RAJA,P
4)GUPTA, Lovi Raj

(57) Abstract :

A robotic machine learning assisted system for tutoring, for assisting the learners in the education by engaging in an interactive learning method. The learning process of the learner is improved by updating the study-module of the learner by access the learning skill of the learner. This system helps the children to learn in an interactive way.

No. of Pages : 13 No. of Claims : 7

(12) PATENT APPLICATION PUBLICATION

(21) Application
No.201911049489 A

(19) INDIA

(22) Date of filing of Application :02/12/2019

(43) Publication Date :
20/12/2019

(54) Title of the invention : A PORTABLE AND ADJUSTABLE PRUNING DEVICE

(51)
International :A01G0003080000,A01G0003025000,B27B0017000000,A61B0017068000,A01G0003037000
classification
(31) Priority
Document :NA
No
(32) Priority :NA
Date
(33) Name
of priority :NA
country
(86)
International
Application :NA
No :NA
Filing
Date
(87)
International
Publication : NA
No
(61) Patent
of Addition
to
Application :NA
Number :NA
Filing
Date
(62)
Divisional to
Application :NA
Number :NA
Filing
Date

(71)Name of Applicant
:
**1)Lovely
Professional University**
Address of
Applicant :Lovely
Professional University,
Jalandhar-Delhi GT
road Phagwara- 144411.
Punjab India
(72)Name of Inventor :
**1)SINGH, Mandeep
2)CHOUDHURY,
Ruhul Amin
3)GUPTA, Lovi Raj
4)KUMAR, Anant**

(57) Abstract :

The present invention discloses a pruning device to prune branches of trees by standing on ground. The portable pruning device consists of a motor (3), a motor body (2), a holding handle (1), a battery (4), an outer hollow shaft (7), a length lock knob (10), an inner shaft (8), a water drop slide assembly (9), a holding clamp (12), a clamp lever (5), a clamp control rod (6), a bevel gear (11) and a cutter (13). There is no requirement of using some uplifted staircase or similar material for pruning branches of trees. The device decreases risk of accidents as pruning can be done from distance.

No. of Pages : 11 No. of Claims : 3

(12) PATENT APPLICATION PUBLICATION

(21) Application
No.201911049490 A

(19) INDIA

(22) Date of filing of Application :02/12/2019

(43) Publication Date :
20/12/2019

(54) Title of the invention : GAS LEAKAGE DETECTION AND RESOLVE SYSTEM

(51)
International :F23N0005240000,G01N0021170000,F23N0005180000,G08B0021160000,F01N0013180000
classification
(31) Priority
Document :NA
No
(32) Priority :NA
Date
(33) Name
of priority :NA
country
(86)
International
Application :NA
No :NA
Filing
Date
(87)
International : NA
Publication
No
(61) Patent
of Addition
to
Application :NA
Number :NA
Filing
Date
(62)
Divisional to
Application :NA
Number :NA
Filing
Date

(71)**Name of Applicant :**
**1)Lovely Professional
University**
Address of Applicant
:Lovely Professional
University, Delhi
Jalandhar GT road
Phagwara- 144411.
Punjab India
(72)**Name of Inventor :**
**1)CHOUDHURY,
Ruhul Amin**
2)SINGH, Mandeep
3)JANGRA, Ashish

(57) Abstract :

Disclosed is a system which consists of a gas detector, a controller, a gas valve, a mobile phone and an exhaust fan. The present invention uses the gas detector to detect the gas in the area where gas detector is installed and when the gas detector detects the gas leakage, the controller controls the valve fitted in the gas pipe and immediately turns off the gas supply by closing the gas valve and switch on the exhaust fan to spread leakage gas out of the kitchen. The present invention sends a notification to the user about detection of gas leakage and after resolving this problem. The present invention provides a cost-effective solution.

No. of Pages : 10 No. of Claims : 6

(12) PATENT APPLICATION PUBLICATION

(21) Application
No.201911049491 A

(19) INDIA

(22) Date of filing of Application :02/12/2019

(43) Publication Date :
20/12/2019

(54) Title of the invention : RAPID GAS GEYSER HAZARD PREVENTION SYSTEM

(51)
International :G01N0033000000,G08B0021140000,F23N0005240000,G06Q0010100000,G08B0017117000
classification
(31) Priority
Document :NA
No
(32) Priority :NA
Date
(33) Name
of priority :NA
country
(86)
International
Application :NA
No :NA
Filing
Date
(87)
International : NA
Publication
No
(61) Patent
of Addition
to
Application :NA
Number :NA
Filing
Date
(62)
Divisional to
Application :NA
Number :NA
Filing
Date

(71)**Name of Applicant**
:
**1)Lovely Professional
University**
Address of
Applicant :Lovely
Professional University,
Delhi Jalandhar GT road
Phagwara- 144411.
Punjab India
(72)**Name of Inventor :**
1)MANDAL, Danvir
2)DHARMANI,
Bhavesh Kumar C.
3)SINGH, Rajesh
4)GEHLOT, Anita

(57) Abstract :

Disclosed is a system to continuously monitor the level of carbon monoxide generates by a gas geyser using a carbon monoxide sensor and when the level of carbon monoxide exceeds the dangerous/threshold level, the system generates an alarm using a buzzer outside the bathroom and sends a message to concerned person through a GSM module. The present invention shut down the gas geyser using a relay when the carbon monoxide level exceeds above the threshold level.

No. of Pages : 10 No. of Claims : 6

(12) PATENT APPLICATION PUBLICATION

(21) Application
No.201911049523 A

(19) INDIA

(22) Date of filing of Application :02/12/2019

(43) Publication Date :
20/12/2019

(54) Title of the invention : HIGH SPEED CUTTING PRESSURIZED COOLANT FLOW INTERNAL COOLING DRILL BIT

<p>(51) International :B23Q0011100000,B23Q0011120000,B23B0051060000,B28D0001040000,B23B0051000000 classification (31) Priority Document :NA No (32) Priority Date :NA (33) Name of priority :NA country (86) International Application :NA No :NA Filing Date (87) International Publication : NA No (61) Patent of Addition to Application :NA Number :NA Filing Date (62) Divisional to Application :NA Number :NA Filing Date</p>	<p>(71)Name of Applicant : 1)Nomendra Tomar Address of Applicant :Department of Mechanical Engineering, Meerut Institute of Engineering & Technology, NH-58 Near Baghat Crossing, Delhi-Roorkee Highway, Meerut Uttar Pradesh India 250005 Uttar Pradesh India 2)Meerut Institute of Engineering & Technology 3)Dr. Awani Bhushan 4)Dr. Swapan Suman 5)Dr. Bhupendra Singh Chauhan (72)Name of Inventor : 1)Nomendra Tomar 2)Dr. Awani Bhushan 3)Dr. Swapan Suman</p>
--	---

(57) Abstract :

The present subject matter relates to high speed cutting pressurized coolant flow internal cooling drill bit including a drill bit housing (1) provided over a drill bit shank (1) which is designed with four holes (3, 4) oriented at two perpendicular locations such that the housing (1) is guarded by a rubber shield ball bearing (7) to maintain drill speed without interruption. Further, the design modification in the shank (2) by which the flow of coolant is pressurizes inside the drill bit without any external power source. The extent of cooling depends on the drill bit rotational speed due to modified design of the shank (2), thereby enhancing the cutting speed with appropriate cooling effect without any power source.

No. of Pages : 20 No. of Claims : 7

(12) PATENT APPLICATION PUBLICATION

(21) Application
No.201911049530 A

(19) INDIA

(22) Date of filing of Application :02/12/2019

(43) Publication Date :
20/12/2019

(54) Title of the invention : A COMPATIBLE CHARGING DEVICE FOR MOBILE PHONE

(51)
International :G06Q0020320000,H04M0001725000,G06F0009451000,H04M0019040000,H04W0092020000
classification

(31) Priority
Document :NA
No

(32) Priority
Date :NA

(33) Name
of priority :NA
country

(86)
International
Application :NA
No :NA

Filing
Date

(87)
International
Publication : NA
No

(61) Patent
of Addition
to
Application :NA
Number :NA

Filing
Date

(62)
Divisional to
Application :NA
Number :NA

Filing
Date

(71)Name of
Applicant :
**1)Lovely
Professional
University**
Address of
Applicant :Lovely
Professional
University Jalandhar-
Delhi G.T. Road,
Phagwara, Punjab-144
411, India Punjab
India

(72)Name of Inventor
:
1)SINGH, Mandeep
**2)CHOUDHURY,
Ruhul Amin**
**3)KUMAR, Juluri
Bharath**

(57) Abstract :

A device which is used to charge the mobile for a specific time period , when the phone is turned off automatically due to lack of charge in the mobile phone by using various aspects of power generation. The device is small, lightweight and compatible with any mobile phone.

No. of Pages : 10 No. of Claims : 6

(12) PATENT APPLICATION PUBLICATION

(21) Application
No.201911049531 A

(19) INDIA

(22) Date of filing of Application :02/12/2019

(43) Publication Date :
20/12/2019

(54) Title of the invention : AN INTELLIGENT MONITORING SYSTEM FOR GROCERY CONSUMPTION

(51)
International :H04W0004700000,G08B0021040000,G08B0021180000,G08B0021020000,B62B0003140000
classification

(31) Priority
Document :NA
No

(32) Priority
Date :NA

(33) Name
of priority :NA
country

(86)
International
Application :NA
No :NA

Filing
Date

(87)
International
Publication : NA
No

(61) Patent
of Addition
to
Application :NA
Number :NA

Filing
Date

(62)
Divisional to
Application :NA
Number :NA

Filing
Date

(71)Name of Applicant
:

**1)Lovely
Professional
University**
Address of
Applicant :Lovely
Professional University
Jalandhar-Delhi G.T.
Road, Phagwara,
Punjab-144 411, India
Punjab India

(72)Name of Inventor :

**1)CHOUDHRY,
Ruhul Amin
2)SINGH,Mandeep**

(57) Abstract :

Disclosed is a system for an intelligent monitoring for grocery consumption for a kitchen cabinet . This system alerts the user when the monthly grocery is required. The system is IoT enabled and Wi-Fi module is used for communication to the user end mobile application to alert or provide an indication for the grocery requirement.

No. of Pages : 10 No. of Claims : 7

(12) PATENT APPLICATION PUBLICATION

(21) Application
No.201911049532 A

(19) INDIA

(22) Date of filing of Application :02/12/2019

(43) Publication Date :
20/12/2019

(54) Title of the invention : AN ADJUSTABLE GLASS CAP

(51)
International :A47G0019220000,C03B0005235000,A61N0005060000,B65D0055020000,A45F0005000000
classification
(31) Priority
Document :NA
No
(32) Priority :NA
Date
(33) Name
of priority :NA
country
(86)
International
Application :NA
No :NA
Filing
Date
(87)
International
Publication : NA
No
(61) Patent
of Addition
to
Application :NA
Number :NA
Filing
Date
(62)
Divisional to
Application :NA
Number :NA
Filing
Date

(71)**Name of Applicant**
:
**1)Lovely Professional
University**
Address of Applicant
:Lovely Professional
University Jalandhar-
Delhi G.T. Road,
Phagwara, Punjab-144
411, India Punjab India
(72)**Name of Inventor :**
1)SINGH, Manpreet
2)GULATI, Piyush
**3)SINGH, Jaiinder
Preet**
4)SINGH, Rajesh
5)SINGH, Satnam
6)SINGH, Sandeep

(57) Abstract :

Disclosed is an adjustable class cap which consists of a top sealed locking; a sealed rings inside cap; an adjustable cap; a cap bottom; a glass; a cap top and a finger clip. The present invention uses an adjustable glass cap to solve the problem of spilling liquid from the glass as well as the top sealed locking is provided at the top of the cap for drinking liquid inside the glass. This provides a cost-effective solution and easy to carry and use.

No. of Pages : 10 No. of Claims : 5

(12) PATENT APPLICATION PUBLICATION

(21) Application
No.201911049533 A

(19) INDIA

(22) Date of filing of Application :02/12/2019

(43) Publication Date :
20/12/2019

(54) Title of the invention : INTELLIGENT DEVICE FOR WRITING

(51)
International :H05B0033080000,G06K0007100000,F21V0023040000,H04M0019040000,G01D0005340000
classification
(31) Priority
Document :NA
No
(32) Priority :NA
Date
(33) Name
of priority :NA
country
(86)
International
Application :NA
No :NA
Filing
Date
(87)
International
Publication : NA
No
(61) Patent
of Addition
to
Application :NA
Number :NA
Filing
Date
(62)
Divisional to
Application :NA
Number :NA
Filing
Date

(71)**Name of Applicant**
:
**1)Lovely
Professional
University**
Address of
Applicant :Lovely
Professional University
Jalandhar-Delhi G.T.
Road, Phagwara,
Punjab-144 411, India
Punjab India
(72)**Name of Inventor :**
**1)SINGH, Mandeep
2)CHOUDHURY,
Amin Ruhul
3)RAJPUT, Anant**

(57) Abstract :

A device is composed of LED's, Light sensor, Intensity control module, Battery cell based and Intensity control unit. The attachment is disposed with plurality of sensors to receive the data and trigger the light. The LED light strip can be bent at different angles on the shaft member, thereby adjusting the illumination angle. The light bar is connected by a ball and socket joint. The intensity of the illuminating embodiment can be adjusted as per the input receives from the plurality of sensors

No. of Pages : 10 No. of Claims : 6

(12) PATENT APPLICATION PUBLICATION

(21) Application
No.201911049546 A

(19) INDIA

(22) Date of filing of Application :02/12/2019

(43) Publication Date :
20/12/2019

(54) Title of the invention : DIAGNOSTIC THERAPEUTIC MACHINE (DTM)

(51)
International :A61B0005000000,G16H0010600000,A61B0005103000,G07F0005180000,G07F0011000000
classification
(31) Priority
Document :NA
No
(32) Priority
Date :NA
(33) Name
of priority :NA
country
(86)
International
Application :NA
No :NA
Filing
Date
(87)
International
Publication : NA
No
(61) Patent
of Addition
to
Application :NA
Number :NA
Filing
Date
(62)
Divisional to
Application :NA
Number :NA
Filing
Date

(71)**Name of Applicant**
:
**1)DR. ARVIND
AGARWAL S/O.
LATE. SH. T.K.
AGARWAL**
Address of Applicant
:C-25, BHAGAT
SINGH MARG, TILAK
NAGAR, JAIPUR-
302004 (RAJ.) Rajasthan
India
(72)**Name of Inventor :**
**1)DR. ARVIND
AGARWAL S/O.
LATE. SH. T.K.
AGARWAL**

(57) Abstract :

The present invention provides a Health Medical Kiosk system for communicating video, voice and medical data between a central monitoring station and a patient monitoring station which is remotely-located with respect to the central monitoring station. The KIOSK obtains digital video, voice and medical measurement data from a patient and encapsulates the data in packets and sends the packets over a network to the central monitoring station. The physician station includes means for capturing image data received from the patient station and storing the captured image data into a medical record. In the preferred embodiment the system is able to teleconference more than two stations at a time.

No. of Pages : 17 No. of Claims : 2

(12) PATENT APPLICATION PUBLICATION

(21) Application
No.201911049725 A

(19) INDIA

(22) Date of filing of Application :03/12/2019

(43) Publication Date :
20/12/2019

(54) Title of the invention : DEVICE FOR LOCATING VEHICLE AND METHOD THEREOF

(51)
International :A61B0008000000,H04L0029080000,G05D0001000000,H04W0008000000,B64C0039020000
classification

(31) Priority
Document :NA
No

(32) Priority
Date :NA

(33) Name
of priority :NA
country

(86)
International
Application :NA
No :NA

Filing
Date

(87)
International
Publication : NA
No

(61) Patent
of Addition
to
Application :NA
Number :NA

Filing
Date

(62)
Divisional to
Application :NA
Number :NA

Filing
Date

(71)Name of Applicant
:

**1)Chitkara
Innovation Incubator
Foundation**

Address of
Applicant :SCO: 160-
161, Sector -9c,
Madhya Marg,
Chandigarh- 160009,
India. Chandigarh India

(72)Name of Inventor :

**1)SHARMA,
Sanjeev Kumar
2)JAIN, Arpit
3)SAXENA, Abhay
4)KHURANA,
Meenu
5)SHARMA, Sanjay
6)SINGH, Arun
Pratap**

(57) Abstract :

According an embodiment, the present disclosure provides a vehicle locating device. The device includes a relay configured with ignition system of the vehicle; a transceiver to receive a communication signal from a computing device associated with a user; a control unit operatively coupled with the transceiver and the relay to: extract a set of features from the received communication signal, wherein a first set of features is selected from the extracted set of features pertaining to a unique identifier associated with the user; and authenticate the user by matching the unique identifier with a dataset comprising a set of prestored identifiers, wherein based on positive authentication of the user, the control unit is configured to generate an output signal, and wherein on receipt of the output signal the relay configured to turn ON the ignition system of the vehicle if the ignition system is turned OFF, and wherein transmit the output signal to the computing device indicating position of the turned ON vehicle.

No. of Pages : 15 No. of Claims : 8

(12) PATENT APPLICATION PUBLICATION

(21) Application
No.201911049732 A

(19) INDIA

(22) Date of filing of Application :03/12/2019

(43) Publication Date :
20/12/2019

(54) Title of the invention : A PROCESS FOR SYNTHESIS OF NANO PARTICLES OF $\text{LiNi}_0.5\text{Co}_0.5\text{PO}_4$ (LNCP) AND USE THEREOF

(51)
International :H01M0004505000,H01M0004525000,H01M0010052500,H04L0029060000,H01M0004020000
classification

(31) Priority
Document :NA
No

(32) Priority :NA
Date

(33) Name
of priority :NA
country

(86)
International
Application :NA
No :NA

Filing
Date

(87)
International : NA
Publication
No

(61) Patent
of Addition
to
Application :NA
Number :NA

Filing
Date

(62)
Divisional to
Application :NA
Number :NA

Filing
Date

(71)Name of
Applicant :
**1)Indian Institute
of Technology
Kanpur**
Address of
Applicant :Dean,
Research &
Development, Room
Number 151, Faculty
Building, Post Office:
IIT Kanpur, Kanpur,
Uttar Pradesh -
208016, India Uttar
Pradesh India

(72)Name of
Inventor :
**1)Kamal Krishna
Kar**
**2)Janakarajan
Ramkumar**
**3)Kiran Kumar
Surthi**

(57) Abstract :

The present disclosure provides for a process for synthesis of nano particles of $\text{LiNi}_0.5\text{Co}_0.5\text{PO}_4$ (LNCP). The process includes mixing one or more compounds selected from a group in a predefined molar ratio to obtain a first mixture acting as a precursor for the nano particles of $\text{LiNi}_0.5\text{Co}_0.5\text{PO}_4$. The group consists of $(\text{NH}_2)_2\text{CO}$, H_3PO_4 , NaOH , NH_4F , SDS , NaOH , C_2O_4 , NiSO_4 , ethylene glycol and deionized water. The nano particles comprise one of nano spheres of $\text{LiNi}_0.5\text{Co}_0.5\text{PO}_4$, nano sheets of $\text{LiNi}_0.5\text{Co}_0.5\text{PO}_4$, and nano plates of $\text{LiNi}_0.5\text{Co}_0.5\text{PO}_4$. Further, purifying the mixture and carrying out solvothermal lithiation of the purified nano-particles of $\text{NH}_4(\text{Ni}_0.5\text{Co}_0.5\text{PO}_4)_2\text{H}_2\text{O}$ to obtain the nano-particles of the $\text{LiNi}_0.5\text{Co}_0.5\text{PO}_4$. The present disclosure also provides for a lithium ion secondary battery having an active cathode material comprising nano-particles of $\text{LiNi}_0.5\text{Co}_0.5\text{PO}_4$. The high capacity cathodes of nano-particles of $\text{LiNi}_0.5\text{Co}_0.5\text{PO}_4$ are highly suitable for Li-ion HEVs and EVs battery applications.

No. of Pages : 55 No. of Claims : 16

(12) PATENT APPLICATION PUBLICATION

(21) Application
No.201911049733 A

(19) INDIA

(22) Date of filing of Application :03/12/2019

(43) Publication Date :
20/12/2019

(54) Title of the invention : ANTI CHAIR FALLING MECHANISM ASSEMBLY

(51)
International :A47D0001000000,A47D0015000000,H01L0021780000,A61F0002950000,A47D0001100000
classification

(31) Priority
Document :NA
No

(32) Priority
Date :NA

(33) Name
of priority :NA
country

(86)
International
Application :NA
No :NA

Filing
Date

(87)
International
Publication : NA
No

(61) Patent
of Addition
to
Application :NA
Number :NA

Filing
Date

(62)
Divisional to
Application :NA
Number :NA

Filing
Date

(71)**Name of Applicant**
:
**1)Lovely Professional
University**

Address of
Applicant :Lovely
Professional University
Jalandhar-Delhi G.T.
Road, Phagwara,
Punjab-144 411, India
Punjab India

(72)**Name of Inventor :**
1)Mandeep Singh
2)Pankaj Singh
**3)Juluri Bharath
Kumar**

(57) Abstract :

A device for protecting kids from falling from chair which consists of a stretchable hooks and screw mechanism for fastening the leg of the child with the chair so that the child doesn't fall off.

No. of Pages : 10 No. of Claims : 5

(12) PATENT APPLICATION PUBLICATION

(21) Application
No.201911049734 A

(19) INDIA

(22) Date of filing of Application :03/12/2019

(43) Publication Date :
20/12/2019

(54) Title of the invention : AN INTELLIGENT WATER PURIFIER

(51)
International :C02F0001280000,C02F0001000000,C02F0009000000,H04L0001000000,C02F0001020000
classification

(31) Priority
Document :NA
No

(32) Priority
Date :NA

(33) Name
of priority :NA
country

(86)
International
Application :NA
No :NA

Filing
Date

(87)
International
Publication : NA
No

(61) Patent
of Addition
to
Application :NA
Number :NA

Filing
Date

(62)
Divisional to
Application :NA
Number :NA

Filing
Date

(71)**Name of Applicant :**
**1)Lovely Professional
University**

Address of Applicant
:Lovely Professional
University Jalandhar-
Delhi G.T. Road,
Phagwara, Punjab-144
411, India Punjab India

(72)**Name of Inventor :**
1)GUPTA, Lovi Raj
2)GEHLOT, Anita
3)SINGH, Rajesh
**4)PRAJAPAT, Mahesh
Kumar**
5)SINGH, Onkar

(57) Abstract :

Disclosed is an intelligent water purifier which consists of a TDS to represent total concentration of dissolved substances in water; a PH value; a microcontroller board to process the data and give output; a power supply to provide power to attached components, a GPRS (General Packet Radio Services) for wireless communication, a red LED, a green LED, a cloud server and an application. The present invention shows output on water purifier by glowing LED's; the red LED represents the water quality and filter quality is bad, and the green LED represents the water quality and filter quality is good. The present invention provides percentage of purified water and working condition of filters of water purifiers with respect to the flow of water on individual app. The present invention is easy to use and maintain as well as involves low cost.

No. of Pages : 10 No. of Claims : 5

(12) PATENT APPLICATION PUBLICATION

(21) Application
No.201911049735 A

(19) INDIA

(22) Date of filing of Application :03/12/2019

(43) Publication Date :
20/12/2019

(54) Title of the invention : WRITING ASSISTANT

(51)
International :F16C0011040000,F16L0037092000,H01L0023000000,B24B0013005000,B29C0049060000
classification

(31) Priority
Document :NA
No

(32) Priority
Date :NA

(33) Name
of priority :NA
country

(86)
International
Application :NA
No :NA

Filing
Date

(87)
International
Publication : NA
No

(61) Patent
of Addition
to
Application :NA
Number :NA

Filing
Date

(62)
Divisional to
Application :NA
Number :NA

Filing
Date

(71)**Name of Applicant :**
**1)Lovely Professional
University**

Address of Applicant
:Lovely Professional
University Jalandhar-
Delhi G.T. Road,
Phagwara, Punjab-144
411, India Punjab India

(72)**Name of Inventor :**

1)RAJPUT, Anant
2)SINGH, Mandeep
3)CHOUDHURY,
Amin Ruhul
4)Ravi Kumar

(57) Abstract :

A writing assistant extension rod, which contains a rod body, a movable collet, a casing, a back blocking ring, an annular front blocking bump and an eraser, wherein the movable collet is arranged at one end of the rod body; the casing is arranged on the movable collet, and is used for fixedly clamping the movable collet of a pencil; the back blocking ring is arranged at the joint between the movable collet and the rod body.

No. of Pages : 9 No. of Claims : 2

(12) PATENT APPLICATION PUBLICATION

(21) Application
No.201911049736 A

(19) INDIA

(22) Date of filing of Application :03/12/2019

(43) Publication Date :
20/12/2019

(54) Title of the invention : A METHOD TO ENHANCE SOLUBILITY OF SIMVASTATIN

(51)
International :C07D0309300000,C08F0283120000,A61K0031366000,C08F0226000000,H04W0012060000
classification
(31) Priority
Document :NA
No
(32) Priority :NA
Date
(33) Name
of priority :NA
country
(86)
International
Application :NA
No :NA
Filing
Date
(87)
International : NA
Publication
No
(61) Patent
of Addition
to
Application :NA
Number :NA
Filing
Date
(62)
Divisional to
Application :NA
Number :NA
Filing
Date

(71)**Name of Applicant**
:
**1)Lovely Professional
University**
Address of
Applicant :Lovely
Professional University
Jalandhar-Delhi G.T.
Road, Phagwara,
Punjab-144 411, India
Punjab India
(72)**Name of Inventor :**
1)KUMAR, Pankaj
2)PANDEY,
Narendra Kumar
3)SINGH, Sachin
Kumar
4)KUMAR, Bimlesh
5)GULATI, Monica

(57) Abstract :

The present invention discloses a method to enhance solubility of simvastatin. The method consists of making co-crystals using various ratios of co-formers to enhance solubility of simvastatin. The co-crystals of simvastatin are stable and method of preparation of co-crystals is simple.

No. of Pages : 10 No. of Claims : 3

(12) PATENT APPLICATION PUBLICATION

(21) Application
No.201911049737 A

(19) INDIA

(22) Date of filing of Application :03/12/2019

(43) Publication Date :
20/12/2019

(54) Title of the invention : SPEECH BASED EMOTIONAL HEALTH GUIDE

(51)
International :A61B0005000000,A61B0005010000,G06F0017270000,H04M0001725000,A63B0024000000
classification
(31) Priority
Document :NA
No
(32) Priority :NA
Date
(33) Name
of priority :NA
country
(86)
International
Application :NA
No :NA
Filing
Date
(87)
International : NA
Publication
No
(61) Patent
of Addition
to
Application :NA
Number :NA
Filing
Date
(62)
Divisional to
Application :NA
Number :NA
Filing
Date

(71)**Name of Applicant**
:
**1)Lovely
Professional University**
Address of
Applicant :Lovely
Professional University
Jalandhar-Delhi G.T.
Road, Phagwara,
Punjab-144 411, India
Punjab India
(72)**Name of Inventor :**
**1)DHARMANI,
Choithram
Bhaveshkumar**
2)SINGH, Rajesh
3)GEHLOT, Anita
**4)RATHOUR,
Navjot**

(57) Abstract :

A novel system for emotional intelligence which consists of plurality of sensors, speech analysis, controlling unit and a display unit. The system works on verbal text analysis along with other parameters like body temperature, heart beat sensor or many more to identify emotional health status of individual.

No. of Pages : 13 No. of Claims : 7

(12) PATENT APPLICATION PUBLICATION

(21) Application
No.201911049738 A

(19) INDIA

(22) Date of filing of Application :03/12/2019

(43) Publication Date :
20/12/2019

(54) Title of the invention : A CHAPATI ROLLER WITH VARIABLE DIAMETER

(51)
International :E05B0019000000,E05B0027000000,B01L0009060000,A63H0033100000,B29B0017020000
classification
(31) Priority
Document :NA
No
(32) Priority :NA
Date
(33) Name
of priority :NA
country
(86)
International
Application :NA
No :NA
Filing
Date
(87)
International : NA
Publication
No
(61) Patent
of Addition
to
Application :NA
Number :NA
Filing
Date
(62)
Divisional to
Application :NA
Number :NA
Filing
Date

(71)**Name of Applicant :**
**1)Lovely Professional
University**
Address of Applicant
:Lovely Professional
University Jalandhar-
Delhi G.T. Road,
Phagwara, Punjab-144
411, India Punjab India
(72)**Name of Inventor :**
1)SINGH, Mandeep
2)CHOUDHURY,
Ruhul Amin
3)GUPTA, Lovi Raj

(57) Abstract :

The present invention consists of a basic chapati roller with attachable cylindrical rollers which can be mounted on to the basic size and the diameter can be adjusted accordingly as per requirements. The present disclosure consist of a base roller of standard size i.e. 4 cm diameter, a cylindrical hollow assembly which can be mounted on base size, a locking pins to lock the assemblies.

No. of Pages : 17 No. of Claims : 5

(12) PATENT APPLICATION PUBLICATION

(21) Application
No.201911049739 A

(19) INDIA

(22) Date of filing of Application :03/12/2019

(43) Publication Date :
20/12/2019

(54) Title of the invention : A SYSTEM TO GENERATE KEY FOR HARDWARE AUTHENTICATION

(51)
International :H04L0009000000,H04L0009080000,H04L0009320000,G06F0021750000,G09C000100000
classification

(31) Priority
Document :NA
No

(32) Priority
Date :NA

(33) Name
of priority :NA
country

(86)
International
Application :NA
No :NA

Filing
Date

(87)
International
Publication : NA
No

(61) Patent
of Addition
to
Application :NA
Number :NA

Filing
Date

(62)
Divisional to
Application :NA
Number :NA

Filing
Date

(71)Name of Applicant :
**1)Lovely Professional
University**

Address of Applicant
:Lovely Professional
University Jalandhar-
Delhi G.T. Road,
Phagwara, Punjab-144
411, India Punjab India

(72)Name of Inventor :
**1)KUMAR, Abhishek
2)PATHAK, Jyotirmo**

**3)TRIPATHI, Suman
Lata**

(57) Abstract :

A system to generate key for hardware architecture with PUF circuit generator, where the response is generated as a function of input challenge and measurable physical characteristics of the chip that end up with stable state. The selection of physical characteristics from chips makes the response unpredictable to others. This system prevents side-channel attack on the hardware unit.

No. of Pages : 24 No. of Claims : 9

(12) PATENT APPLICATION PUBLICATION

(21) Application
No.201911049740 A

(19) INDIA

(22) Date of filing of Application :03/12/2019

(43) Publication Date :
20/12/2019

(54) Title of the invention : AN IOT BASED ALERT SYSTEM TO PROTECT INFANTS FROM HAZARDOUS OBJECTS

(51)
International :H04R0029000000,H04R0003000000,A63F0009180000,B29C0065000000,A63F0013400000
classification
(31) Priority
Document :NA
No
(32) Priority :NA
Date
(33) Name
of priority :NA
country
(86)
International
Application :NA
No :NA
Filing
Date
(87)
International
Publication : NA
No
(61) Patent
of Addition
to
Application :NA
Number :NA
Filing
Date
(62)
Divisional to
Application :NA
Number :NA
Filing
Date

(71)**Name of Applicant :**
**1)Lovely Professional
University**
Address of Applicant
:Lovely Professional
University Jalandhar-
Delhi G.T. Road,
Phagwara, Punjab-144
411, India Punjab India
(72)**Name of Inventor :**
1)GUPTA, Lovi Raj
2)ANEJA, Sakshi
3)GEHLOT, Anita
4)RATHOUR, Navjot
5)S, Arjun
**6)DAS, Prabin
Kumar**

(57) Abstract :

An IoT based alert system that prevents casualties by detecting hazardous objects present in the vicinity or in contact with an infant. The system consists of two servo motors, Raspberry Pi, camera, neural compute stick, microphone, and a speaker. The system is capable to function like a chatbot which can be used by the child as well as the family members to ask various fun questions, play some quiz games.

No. of Pages : 12 No. of Claims : 5

(12) PATENT APPLICATION PUBLICATION

(21) Application
No.201911049742 A

(19) INDIA

(22) Date of filing of Application :03/12/2019

(43) Publication Date :
20/12/2019

(54) Title of the invention : AN ANTI-DIABETIC FORMULATION OF OPERCULINA TURPETHUM

(51)
International :A61K0009000000,A61K0008970000,A61K0031350000,A61K0009160000,A01N0063020000
classification
(31) Priority
Document :NA
No
(32) Priority :NA
Date
(33) Name
of priority :NA
country
(86)
International
Application :NA
No :NA
Filing
Date
(87)
International
Publication : NA
No
(61) Patent
of Addition
to
Application :NA
Number :NA
Filing
Date
(62)
Divisional to
Application :NA
Number :NA
Filing
Date

(71)**Name of Applicant**
:
**1)Lovely
Professional
University**
Address of
Applicant :Lovely
Professional University
Jalandhar-Delhi G.T.
Road, Phagwara,
Punjab-144 411, India
Punjab India
(72)**Name of Inventor**
:
**1)SUTTEE, Ashish
2)CHOUDHARY,
Neeraj**

(57) Abstract :

The present invention discloses a novel anti-diabetic formulation of Operculina turpethum. The formulation consists of flavanoid rich fraction of extract of Operculina turpethum (roots/rhizome) and pharmaceutically acceptable excipients. The formulation of present invention can be loaded and delivered in novel drug delivery systems. The formulation showed alpha-amylase inhibitory activity in in-vitro assays.

No. of Pages : 10 No. of Claims : 5

(12) PATENT APPLICATION PUBLICATION

(21) Application
No.201911049744 A

(19) INDIA

(22) Date of filing of Application :03/12/2019

(43) Publication Date :
20/12/2019

(54) Title of the invention : PROJECTOR LAMP LIFE SAVER CUT OFF CIRCUIT

(51)
International :H04N0009310000,H04N0005740000,G06F0001300000,H04B0001160000,H01M0008043200
classification

(31) Priority
Document :NA
No

(32) Priority
Date :NA

(33) Name
of priority :NA
country

(86)
International
Application :NA
No :NA

Filing
Date

(87)
International
Publication : NA
No

(61) Patent
of Addition
to
Application :NA
Number :NA

Filing
Date

(62)
Divisional to
Application :NA
Number :NA

Filing
Date

(71)Name of Applicant
:

**1)Lovely
Professional
University**
Address of
Applicant :Lovely
Professional University
Jalandhar-Delhi G.T.
Road, Phagwara,
Punjab-144 411, India
Punjab India

(72)Name of Inventor :

**1)SINGH, Mandeep
2)KOTNI, Manish
3)CHOUDHURY,
Amin Ruhul**

(57) Abstract :

A detachable system which can be installed in any projector circuit. The system consists of a microcontroller, a capacitor and a power unit. The system is cost effective and works when the power supply is cut from the projector.

No. of Pages : 10 No. of Claims : 4

(12) PATENT APPLICATION PUBLICATION

(21) Application
No.201911049745 A

(19) INDIA

(22) Date of filing of Application :03/12/2019

(43) Publication Date :
20/12/2019

(54) Title of the invention : A METHOD TO REMOVE ANTIBIOTICS FROM WATER USING BIOCOMPOSITE MEMBRANE

(51)
International :C02F0001280000,A61L0027360000,C12N0011080000,A61L0031120000,A61B0017040000
classification
(31) Priority
Document :NA
No
(32) Priority :NA
Date
(33) Name
of priority :NA
country
(86)
International
Application :NA
No :NA
Filing
Date
(87)
International :NA
Publication
No
(61) Patent
of Addition
to
Application :NA
Number :NA
Filing
Date
(62)
Divisional to
Application :NA
Number :NA
Filing
Date

(71)**Name of Applicant :**
**1)Lovely Professional
University**
Address of Applicant
:Lovely Professional
University Jalandhar-
Delhi G.T. Road,
Phagwara, Punjab-144
411, India Punjab India
(72)**Name of Inventor :**
1)KAUR, Amarjeet
2)MAITY, Chandan

(57) Abstract :

The present invention discloses a method to remove antibiotics from water using biocomposite membrane. The method to remove antibiotics from water consists of diffusion of the wastewater through biocomposite membrane and irradiation with light. The membrane can be used several times after washing.

No. of Pages : 11 No. of Claims : 5

(12) PATENT APPLICATION PUBLICATION

(21) Application
No.201911049746 A

(19) INDIA

(22) Date of filing of Application :03/12/2019

(43) Publication Date :
20/12/2019

(54) Title of the invention : AN ANTI-DIABETIC FORMULATION OF CHENOPODIUM ALBUM

(51)
International :A61K0008970000,A61K0036185000,A61K0009000000,A61K0036899800,A23L0033105000
classification

(31) Priority
Document :NA
No

(32) Priority
Date :NA

(33) Name
of priority :NA
country

(86)
International
Application :NA
No :NA

Filing
Date

(87)
International
Publication : NA
No

(61) Patent
of Addition
to
Application :NA
Number :NA

Filing
Date

(62)
Divisional to
Application :NA
Number :NA

Filing
Date

(71)Name of Applicant

:
**1)Lovely
Professional
University**

Address of
Applicant :Lovely
Professional University
Jalandhar-Delhi G.T.
Road, Phagwara,
Punjab-144 411, India
Punjab India

(72)Name of Inventor :

**1)SUTTEE, Ashish
2)CHOUDHARY,
Neeraj**

(57) Abstract :

The present invention discloses a novel anti-diabetic formulation of Chenopodium album. The formulation consists of flavanoid rich fraction of extract of Chenopodium album (aerial parts) and pharmaceutically acceptable excipients. The formulation showed alpha-amylase inhibitory activity in in-vitro assays.

No. of Pages : 10 No. of Claims : 5

(12) PATENT APPLICATION PUBLICATION

(21) Application
No.201911049747 A

(19) INDIA

(22) Date of filing of Application :03/12/2019

(43) Publication Date :
20/12/2019

(54) Title of the invention : PUBLIC FIR ASSISTANCE SYSTEM

(51)
International :H04N0007180000,G08B0013196000,G06Q0050100000,G06Q0050180000,H04N0005225000
classification

(31) Priority
Document :NA
No

(32) Priority
Date :NA

(33) Name
of priority :NA
country

(86)
International
Application :NA
No :NA

Filing
Date

(87)
International
Publication : NA

No
(61) Patent
of Addition

to
Application :NA
Number :NA

Filing
Date

(62)
Divisional to

Application :NA
Number :NA

Filing
Date

(71)Name of Applicant
:

**1)Lovely
Professional
University**
Address of
Applicant :Lovely
Professional University
Jalandhar-Delhi G.T.
Road, Phagwara,
Punjab-144 411, India
Punjab India

(72)Name of Inventor :

**1)SINGH, Manpreet
2)SINGH, Sandeep
3)YADAV, Varsha
4)GULATI, Piyush
5)SINGH, Jaiinder
Preet
6)SINGH, Satnam**

(57) Abstract :

The public FIR assistance system is disclosed using which a common man can assess and file the FIR after authenticating his identity. The present invention consists of a cloud server, a FIR assistance system, a display, a Raspberry Pi 3 Model B+, a Fingerprint Module, a keypad, a camera module and a power Supply. This can help a common man to overcome the tedious process of filing FIR in the local police station. This assistance system is connected to all the registered police stations through cloud server. When a person lodges the complaint then this complaint is forwarded to the relevant police station on the basis of address verification. The timeline is also provided to the station head officer through algorithm on the basis of intensity of complaint. This assistance system is also provided with a two-way security and a camera module to keep away the miscreants for making false complaints.

No. of Pages : 14 No. of Claims : 6

(12) PATENT APPLICATION PUBLICATION

(21) Application
No.201911049748 A

(19) INDIA

(22) Date of filing of Application :03/12/2019

(43) Publication Date :
20/12/2019

(54) Title of the invention : WATER QUALITY MEASURING MOBILE CASE

(51)
International :G01N0033180000,C02F0001000000,G06F0003034600,B60R0011000000,H04M0001020000
classification
(31) Priority
Document :NA
No
(32) Priority :NA
Date
(33) Name
of priority :NA
country
(86)
International
Application :NA
No :NA
Filing
Date
(87)
International
Publication : NA
No
(61) Patent
of Addition
to
Application :NA
Number :NA
Filing
Date
(62)
Divisional to
Application :NA
Number :NA
Filing
Date

(71)**Name of Applicant**
:
**1)Lovely Professional
University**
Address of Applicant
:Lovely Professional
University Jalandhar-
Delhi G.T. Road,
Phagwara, Punjab-144
411, India Punjab India
(72)**Name of Inventor :**
1)SINGH, Mandeep
2)KUMAR, Juluri
bharath
3)CHOUDHURY,
Ruhul Amin

(57) Abstract :

Disclosed is a system for water quality measuring mobile case. The present invention consists of a display screen; a sensor; a slider; a control unit integrated on the back of a mobile case for measuring the water quality parameters. The slider is used for opening and closing of the sensor and the measured results displays on the display screen mounted on the back of the mobile case. The control unit controls the operation of integrated components, and a cell is used to provide the power to the components. This invention provides a portable system to find the TDS and PH of the water.

No. of Pages : 12 No. of Claims : 5

(12) PATENT APPLICATION PUBLICATION

(21) Application
No.201911049749 A

(19) INDIA

(22) Date of filing of Application :03/12/2019

(43) Publication Date :
20/12/2019

(54) Title of the invention : A NOVEL MOTOR VEHICLE WINDOW PANE CLOSURE DETECTOR

(51)
International :F02M0037000000,B60R0025100000,F02D0033000000,B60R0025040000,B60N0002420000
classification
(31) Priority
Document :NA
No
(32) Priority :NA
Date
(33) Name
of priority :NA
country
(86)
International
Application :NA
No :NA
Filing
Date
(87)
International : NA
Publication
No
(61) Patent
of Addition
to
Application :NA
Number :NA
Filing
Date
(62)
Divisional to
Application :NA
Number :NA
Filing
Date

(71)**Name of Applicant**
:
**1)Lovely Professional
University**
Address of Applicant
:Lovely Professional
University Jalandhar-
Delhi G.T. Road,
Phagwara, Punjab-144
411, India Punjab India
(72)**Name of Inventor :**
1)SARMA, Rajkumar
2)BHARGAVA,
Cherry
3)KUMAR, Ahishek
4)PATHAK,
Jyotirmoy
5)SHARMA, Pardeep
6)SACHDEVA, Amit

(57) Abstract :

A system to detect an open window pane , when the engine is turned off in a four-wheel motor vehicle. This system prevents locking of the vehicle remotely if any window pane remains open. This system provides safety by preventing vehicle theft.

No. of Pages : 13 No. of Claims : 7

(12) PATENT APPLICATION PUBLICATION

(21) Application
No.201911049750 A

(19) INDIA

(22) Date of filing of Application :03/12/2019

(43) Publication Date :
20/12/2019

(54) Title of the invention : A KIT TO COLLECT AND ANALYZE BITE MARKS

(51)
International :A61B0005040400,A61B0005145000,G06F0016245500,A01K0097120000,A45F0003160000
classification
(31) Priority
Document :NA
No
(32) Priority :NA
Date
(33) Name
of priority :NA
country
(86)
International
Application :NA
No :NA
Filing
Date
(87)
International
Publication : NA
No
(61) Patent
of Addition
to
Application :NA
Number :NA
Filing
Date
(62)
Divisional to
Application :NA
Number :NA
Filing
Date

(71)**Name of Applicant**
:
**1)Lovely Professional
University**
Address of Applicant
:Lovely Professional
University Jalandhar-
Delhi G.T. Road,
Phagwara, Punjab-144
411, India Punjab India
(72)**Name of Inventor :**
1)SINGH, Jaskaran
2)PRAJAPAT,
Mahesh Kumar
3)SHARMA, Neeta
Raj
4)SINGH, Rajesh
5)GEHLOT, Anita
6)MIR, Tahir Ul Gani

(57) Abstract :

The present invention discloses a portable kit to collect and analyze bite marks in forensic cases. The kit to collect and analyze bite marks in forensic cases consists of a bite mark scanner (100), a mean to take imprint (104) of suspect's bite mark and a computer or mobile software. Images captured by the bite mark scanner (100) are transferred to a smartphone or computer based software to compare and give analysis report. The artificial intelligence assisted approach in bite mark analysis encompasses better, accurate and reliable result.

No. of Pages : 16 No. of Claims : 6

(12) PATENT APPLICATION PUBLICATION

(21) Application
No.201911049751 A

(19) INDIA

(22) Date of filing of Application :03/12/2019

(43) Publication Date :
20/12/2019

(54) Title of the invention : INSTANT WATER HEATING BOTTLE

(51)
International :B65D0051240000,H02J0050100000,H02J0007020000,H01L0035300000,C08G0018480000
classification
(31) Priority
Document :NA
No
(32) Priority
Date :NA
(33) Name
of priority :NA
country
(86)
International
Application :NA
No :NA
Filing
Date
(87)
International
Publication : NA
No
(61) Patent
of Addition
to
Application :NA
Number :NA
Filing
Date
(62)
Divisional to
Application :NA
Number :NA
Filing
Date

(71)**Name of Applicant :**
**1)Lovely Professional
University**
Address of Applicant
:Lovely Professional
University Jalandhar-
Delhi G.T. Road,
Phagwara, Punjab-144
411, India Punjab India
(72)**Name of Inventor :**
**1)SINGH, Preet Inder
Jai**
2)UMESH, Syave
3)GULATI, Piyush
4)SINGH, Manpreet
5)SINGH, Harpinder
6)SINGH, Satnam

(57) Abstract :

A water bottle that can heat the water instantly at the time of consumption with the help of thermo electric coils and chargeable power supply.

No. of Pages : 22 No. of Claims : 4

(12) PATENT APPLICATION PUBLICATION

(21) Application
No.201911049786 A

(19) INDIA

(22) Date of filing of Application :03/12/2019

(43) Publication Date :
20/12/2019

(54) Title of the invention : A BIODEGRADABLE DISPOSAL PLATE FROM STUBBLE

(51)
International :G06Q0030060000,G02F0001134300,C08K0005134000,C07D0231560000,C09J0133100000
classification
(31) Priority
Document :NA
No
(32) Priority :NA
Date
(33) Name
of priority :NA
country
(86)
International
Application :NA
No :NA
Filing
Date
(87)
International :NA
Publication
No
(61) Patent
of Addition
to
Application :NA
Number :NA
Filing
Date
(62)
Divisional to
Application :NA
Number :NA
Filing
Date

(71)**Name of Applicant :**
**1)Lovely Professional
University**
Address of Applicant
:Lovely Professional
University Jalandhar-
Delhi G.T. Road,
Phagwara, Punjab-144
411, India Punjab India
(72)**Name of Inventor :**
1)SINGH, Harpreet
2)KHOSLA, Atul
3)WADHAWAN,
Hamaiou
4)KUMAR, Aditya
5)OJHA, Harshit Raj
6)TYAGI, Sumit
7)SHRESHTHA,
Saurav

(57) Abstract :

A disposal plate made from stubble which consists of designing the plate in CREO software, shredding, pulping and molding. The present invention is more effective in making use of the stubble i.e remains after grains, like paddy, wheat are harvested and on the same time a big percentage of air pollution can be dealt with. The present invention is a great alternative which is capable of replacing all the other available products.

No. of Pages : 11 No. of Claims : 6

(12) PATENT APPLICATION PUBLICATION

(21) Application
No.201911049787 A

(19) INDIA

(22) Date of filing of Application :03/12/2019

(43) Publication Date :
20/12/2019

(54) Title of the invention : A METHOD TO ENHANCE SOLUBILITY OF GLIMEPIRIDE

(51)
International :A61K0031640000,A61K0031519000,C07D0487040000,C08F0283120000,H04W0012060000
classification
(31) Priority
Document :NA
No
(32) Priority :NA
Date
(33) Name
of priority :NA
country
(86)
International
Application :NA
No :NA
Filing
Date
(87)
International
Publication : NA
No
(61) Patent
of Addition
to
Application :NA
Number :NA
Filing
Date
(62)
Divisional to
Application :NA
Number :NA
Filing
Date

(71)Name of Applicant
:

**1)Lovely
Professional
University**
Address of
Applicant :Lovely
Professional University
Jalandhar-Delhi G.T.
Road, Phagwara,
Punjab-144 411, India
Punjab India

(72)Name of Inventor :

**1)GULATI, Monica
2)KUMAR, Bimlesh
3)PANDEY,
Narendra Kumar
4)SINGH, Sachin
Kumar
5)HAWARI, Sattar**

(57) Abstract :

The present invention discloses a method to enhance solubility of glimepiride. The method consists of making co-crystals using various ratios of co-formers to enhance solubility of glimepiride particularly 6:4 ratio of salicylic acid and 3-nitrobenzoic acid is used as a co-former. The co-crystals of glimepiride are stable and method of preparation of co-crystals is simple.

No. of Pages : 10 No. of Claims : 3

(12) PATENT APPLICATION PUBLICATION

(21) Application
No.201911049788 A

(19) INDIA

(22) Date of filing of Application :03/12/2019

(43) Publication Date :
20/12/2019

(54) Title of the invention : A NOVEL FORMULATION FOR DIABETES MANAGEMENT

(51)
International :A61K0036220000,G16H0040630000,A61K0009510000,A61K0031703400,A61B0005000000
classification

(31) Priority
Document :NA
No

(32) Priority
Date :NA

(33) Name
of priority :NA
country

(86)
International
Application :NA
No :NA

Filing
Date

(87)
International
Publication : NA
No

(61) Patent
of Addition
to

Application :NA
Number :NA

Filing
Date

(62)
Divisional to
Application :NA

Number :NA
Filing
Date

(71)Name of Applicant
:

**1)Lovely
Professional
University**
Address of
Applicant :Lovely
Professional University
Jalandhar-Delhi G.T.
Road, Phagwara,
Punjab-144 411, India
Punjab India

(72)Name of Inventor :

**1)KAUR, Manpreet
2)BAGHEL, Dileep
Singh
3)MITTAL, Amit
4)SINGH, Saurabh**

(57) Abstract :

The present invention discloses a novel formulation for diabetes management. The novel formulation for management of diabetes mellitus consisting of extracts ofMangifera indica (leaves) (25% to 75%), Brassica juncea (seed) (25% to 75%) and pharmaceutically acceptable additives. The formulation has anti-oxidant and a-amylase inhibitory activity.

No. of Pages : 9 No. of Claims : 4

(12) PATENT APPLICATION PUBLICATION

(21) Application
No.201911049790 A

(19) INDIA

(22) Date of filing of Application :03/12/2019

(43) Publication Date :
20/12/2019

(54) Title of the invention : ROBBERY PREVENTION SYSTEM FOR AUTOMATED TELLER MACHINE

(51)
International :G07F0019000000,G07G0003000000,G06F0021550000,G06T0007000000,E05G0005000000
classification
(31) Priority
Document :NA
No
(32) Priority :NA
Date
(33) Name
of priority :NA
country
(86)
International
Application :NA
No :NA
Filing
Date
(87)
International
Publication : NA
No
(61) Patent
of Addition
to
Application :NA
Number :NA
Filing
Date
(62)
Divisional to
Application :NA
Number :NA
Filing
Date

(71)**Name of Applicant :**
**1)Lovely Professional
University**
Address of Applicant
:Lovely Professional
University Jalandhar-
Delhi G.T. Road,
Phagwara, Punjab-144
411, India Punjab India
(72)**Name of Inventor :**
**1)VERMA,
Bhupinder**
**2)SINGH, Dushyant
Kumar**
3)THAKUR, Bharti

(57) Abstract :

Disclosed is a robbery prevention system for Automated Teller Machine which consists of a Raspberry Pi for an image processing; a camera to capture image in ATM cabin; an alert system to inform bank security or police regarding suspicious activity; and an actuator for locking ATM cabin; an IoT for wireless connectivity. The present invention sends notification and alert to the bank security officers as well as police if any suspicious activity is observed. The system further facilitates to lock the ATM cabin door automatically when observes any suspicious activity.

No. of Pages : 8 No. of Claims : 5

(12) PATENT APPLICATION PUBLICATION

(21) Application
No.201911049791 A

(19) INDIA

(22) Date of filing of Application :03/12/2019

(43) Publication Date :
20/12/2019

(54) Title of the invention : IOT ENABLED SMART WATER HEATING BUCKET

(51)
International :A47J0031560000,F24D0019100000,A47J0027210000,F24H0009200000,G06F0003048200
classification
(31) Priority
Document :NA
No
(32) Priority :NA
Date
(33) Name
of priority :NA
country
(86)
International
Application :NA
No :NA
Filing
Date
(87)
International
Publication : NA
No
(61) Patent
of Addition
to
Application :NA
Number :NA
Filing
Date
(62)
Divisional to
Application :NA
Number :NA
Filing
Date

(71)**Name of Applicant :**
**1)Lovely Professional
University**
Address of Applicant
:Lovely Professional
University Jalandhar-Delhi
G.T. Road, Phagwara,
Punjab-144 411, India
Punjab India
(72)**Name of Inventor :**
1)SINGH,Mandeep
2)CHOUDHURY,
Ruhul Amin
3)KAMALGURU,
Rakesh
4)SINGH , Harpinder

(57) Abstract :

An IoT enabled smart water heating bucket, in which the water temperature will be controlled remotely through an IoT enabled mobile controller as per the user requirement and a display unit, displays the temperature of the water. The device consists of automatic cut-off, when the water is heated to the required temperature.

No. of Pages : 12 No. of Claims : 9

(12) PATENT APPLICATION PUBLICATION

(21) Application
No.201911049792 A

(19) INDIA

(22) Date of filing of Application :03/12/2019

(43) Publication Date :
20/12/2019

(54) Title of the invention : EXTENDED REALITY FOR MEDICAL PRACTITIONERS

(51)
International :G06F0003010000,G02B0027010000,G02B0027040000,G06T0019000000,A61B0005055000
classification
(31) Priority
Document :NA
No
(32) Priority :NA
Date
(33) Name
of priority :NA
country
(86)
International
Application :NA
No :NA
Filing
Date
(87)
International : NA
Publication
No
(61) Patent
of Addition
to
Application :NA
Number :NA
Filing
Date
(62)
Divisional to
Application :NA
Number :NA
Filing
Date

(71)**Name of Applicant**
:
**1)Lovely professional
University**
Address of Applicant
:Lovely Professional
University, Jalandhar-
Delhi GT road
Phagwara- 144411.
Punjab India
(72)**Name of Inventor :**
**1)Sandeep Kumar
Arora**

(57) Abstract :

A system which converts the medical reports to virtual reality for analysis. The system can be used for studying and planning before complicated surgeries.

No. of Pages : 11 No. of Claims : 5

(12) PATENT APPLICATION PUBLICATION

(21) Application
No.201911049793 A

(19) INDIA

(22) Date of filing of Application :03/12/2019

(43) Publication Date :
20/12/2019

(54) Title of the invention : A ROTATABLE MOTORBIKE SEAT

(51)
International :G06Q0040020000,B62J0001140000,A61K0031505000,E05B0019000000,B62J0001000000
classification
(31) Priority
Document :NA
No
(32) Priority :NA
Date
(33) Name
of priority :NA
country
(86)
International
Application :NA
No :NA
Filing
Date
(87)
International
Publication : NA
No
(61) Patent
of Addition
to
Application :NA
Number :NA
Filing
Date
(62)
Divisional to
Application :NA
Number :NA
Filing
Date

(71)**Name of Applicant :**
**1)Lovely Professional
University**
Address of Applicant
:Lovely Professional
University Jalandhar-
Delhi G.T. Road,
Phagwara, Punjab-144
411, India Punjab India
(72)**Name of Inventor :**
**1)SHARMA, Pardeep
Kumar**
**2)BHARGAVA,
Cherry**
3)SARMA, Rajkumar
**4)PATHAK,
Jyotirmoy**
5)KUMAR, Abhishek
6)SACHDEVA, Amit
7)KHAN, Salman

(57) Abstract :

A rotatable motorbike seat is disclosed, which is capable to protect the rider and pillion from the adverse climatic conditions. The present invention consists of a seat joint, a dual color seat and a two-way lock. This rotatable seat is ready to use for sitting purpose by just rotating it upside down in case of rain, scorching heat. The seat is designed in two colors so that versatility and durability of the seat is enhanced.

No. of Pages : 10 No. of Claims : 6

(12) PATENT APPLICATION PUBLICATION

(21) Application
No.201911049964 A

(19) INDIA

(22) Date of filing of Application :04/12/2019

(43) Publication Date :
20/12/2019

(54) Title of the invention : AN INTEGRATED NAVIGATIONAL SYSTEM FOR DEFINED ENVIRONMENT

<p>(51) International :G01C0021360000,G01C0021200000,A61B0034200000,A61H0003060000,G11B0027300000 classification (31) Priority Document :NA No (32) Priority Date :NA (33) Name of priority :NA country (86) International Application :NA No :NA Filing Date (87) International Publication : NA No (61) Patent of Addition to Application :NA Number :NA Filing Date (62) Divisional to Application :NA Number :NA Filing Date</p>	<p>(71)Name of Applicant : 1)Lovely Professional University Address of Applicant :Lovely Professional University Jalandhar-Delhi G.T. Road, Phagwara, Punjab-144 411, India Punjab India (72)Name of Inventor : 1)JAIN, Paras 2)KUMAR, Suraj 3)SHUSHMA, Karnataka 4)SHARMA, Vikas Munna 5)KUMAR, Nitin 6)JAIN, Anuj 7)SINGH, Rajesh</p>
--	---

(57) Abstract :

Disclosed is an integrated navigational system for defined environment. The system consists of a speech recorder/Mic; a Raspberry Pi; a touch display; a battery; a keyboard; and a mouse. The system provides navigation information for a user when the user enters the source and destination data for a fixed route map and guides the user with searching, routing and navigation. There are four to five system installed at number of places and helps the user to relocate and navigate the user from each of those particular system. This invention needs minimum hardware to implement and involves low cost, and gives fast response with or without internet connectivity.

No. of Pages : 15 No. of Claims : 5

(12) PATENT APPLICATION PUBLICATION

(21) Application
No.201911049965 A

(19) INDIA

(22) Date of filing of Application :04/12/2019

(43) Publication Date :
20/12/2019

(54) Title of the invention : AN IOT BASED HOME AUTOMATION SYSTEM

(51)
International :H04L0012280000,G05B0015020000,H04N0007180000,F21V0023040000,A61L0002180000
classification
(31) Priority
Document :NA
No
(32) Priority :NA
Date
(33) Name
of priority :NA
country
(86)
International
Application :NA
No :NA
Filing
Date
(87)
International
Publication : NA
No
(61) Patent
of Addition
to
Application :NA
Number :NA
Filing
Date
(62)
Divisional to
Application :NA
Number :NA
Filing
Date

(71)**Name of Applicant**
:
**1)Lovely Professional
University**
Address of Applicant
:Lovely Professional
University Jalandhar-
Delhi G.T. Road,
Phagwara, Punjab-144
411, India Punjab India
(72)**Name of Inventor :**
**1)PATHAK,
Jyotirmoy**
2)KUMAR ,Pradumn
**3)RAJ, Harsh
Vardhan**
**4)PATEL, Tushar
Singh**

(57) Abstract :

An IoT based home automation system which activates automatically by detecting the environmental characteristics and provides automatic door lock system. This system works on detecting the environmental conditions both indoor and outdoor of the home and works accordingly with no user enabled preferences or characteristics.

No. of Pages : 25 No. of Claims : 8

(12) PATENT APPLICATION PUBLICATION

(21) Application
No.201911049966 A

(19) INDIA

(22) Date of filing of Application :04/12/2019

(43) Publication Date :
20/12/2019

(54) Title of the invention : FATALITY REDUCTION SYSTEM

(51)
International :C09D0007630000,H01L0021311000,G06T0007000000,G06Q0040020000,G06Q0040000000
classification

(31) Priority
Document :NA
No

(32) Priority
Date :NA

(33) Name
of priority :NA
country

(86)
International
Application :NA
No :NA

Filing
Date

(87)
International
Publication : NA
No

(61) Patent
of Addition
to
Application :NA
Number :NA

Filing
Date

(62)
Divisional to
Application :NA
Number :NA

Filing
Date

(71)**Name of Applicant**
:
**1)Lovely Professional
University**

Address of
Applicant :Lovely
Professional University
Jalandhar-Delhi G.T.
Road, Phagwara,
Punjab-144 411, India
Punjab India

(72)**Name of Inventor :**
**1)SHARMA,
Ashutosh**
2)ANEJA, Sakshi
**3)SHARMA, Raj
Neeta**
**4)CHOUDARY,
Sesha Yeluri**

(57) Abstract :

A novel system for fatality reduction which consists of a visualization module, control module, sensory module and an alert module. The system is well advanced to be used in universities and colleges and helps in monitoring of the hostel rooms with ease.

No. of Pages : 10 No. of Claims : 5

(12) PATENT APPLICATION PUBLICATION

(21) Application
No.201911049967 A

(19) INDIA

(22) Date of filing of Application :04/12/2019

(43) Publication Date :
20/12/2019

(54) Title of the invention : FULLY AUTOMATIC MAIN DOOR OPENING SYSTEM

(51)
International :E05F0001000000,E05F0001100000,E05F0003220000,F25D0023020000,G01S0015880000
classification
(31) Priority
Document :NA
No
(32) Priority :NA
Date
(33) Name
of priority :NA
country
(86)
International
Application :NA
No :NA
Filing
Date
(87)
International
Publication : NA
No
(61) Patent
of Addition
to
Application :NA
Number :NA
Filing
Date
(62)
Divisional to
Application :NA
Number :NA
Filing
Date

(71)**Name of Applicant :**
**1)Lovely Professional
University**
Address of Applicant
:Lovely Professional
University Jalandhar-Delhi
G.T. Road, Phagwara,
Punjab-144 411, India
Punjab India
(72)**Name of Inventor :**
**1)SINGH, Dushyant
Kumar**
**2)SINGH , Ashish
Kumar**
3)PARMAR, Deepak

(57) Abstract :

A fully automatic main door opening system, where the signal received from the smart-phone within the coverage area of the WiFi , the door will open automatically for a pre-set time interval . The door will close automatically once the signal goes out of the coverage area of the WiFi module . The door will open and close automatically for the preset time interval.

No. of Pages : 11 No. of Claims : 5

(12) PATENT APPLICATION PUBLICATION

(21) Application
No.201911049968 A

(19) INDIA

(22) Date of filing of Application :04/12/2019

(43) Publication Date :
20/12/2019

(54) Title of the invention : IOT BASED EXTRACTION OF RESEARCH DATA USING DEEP LEARNING NLP

(51)
International :G06K0009620000,G06N0003080000,G06N0003040000,G06K0009660000,G06F0017270000
classification
(31) Priority
Document :NA
No
(32) Priority :NA
Date
(33) Name
of priority :NA
country
(86)
International
Application :NA
No :NA
Filing
Date
(87)
International : NA
Publication
No
(61) Patent
of Addition
to
Application :NA
Number :NA
Filing
Date
(62)
Divisional to
Application :NA
Number :NA
Filing
Date

(71)Name of Applicant
:
**1)Lovely
Professional University**
Address of
Applicant :Lovely
Professional University
Jalandhar-Delhi G.T.
Road, Phagwara,
Punjab-144 411, India
Punjab India
(72)Name of Inventor :
**1)ARORA, Sandeep
Kumar**

(57) Abstract :

A novel system for structured and unstructured data analysis using natural language processing. The system is more advanced as it extracts features and data from images also. The system shares and stores the information in the cloud server and extracts features from the same.

No. of Pages : 12 No. of Claims : 7

(12) PATENT APPLICATION PUBLICATION

(21) Application
No.201911049969 A

(19) INDIA

(22) Date of filing of Application :04/12/2019

(43) Publication Date :
20/12/2019

(54) Title of the invention : A NOVEL SYSTEM FOR DISEASE DETECTION

(51)
International :G06T0007000000,G06T0007110000,G06K0009620000,G06K0009460000,G06K0009340000
classification

(31) Priority
Document :NA
No

(32) Priority
Date :NA

(33) Name
of priority :NA
country

(86)
International
Application :NA
No :NA

Filing
Date

(87)
International
Publication : NA
No

(61) Patent
of Addition
to
Application :NA
Number :NA

Filing
Date

(62)
Divisional to
Application :NA
Number :NA

Filing
Date

(71)Name of Applicant
:
**1)Lovely Professional
University**

Address of
Applicant :Lovely
Professional University
Jalandhar-Delhi G.T.
Road, Phagwara,
Punjab-144 411, India
Punjab India

(72)Name of Inventor :
**1)Dr. Kirti Rawal
2)Dr. Gaurav Sethi**

(57) Abstract :

A novel system for abdomen disease detection is proposed which is more advanced and accurate. The key features include image segmentation, feature extraction, feature selection and disease detection.

No. of Pages : 12 No. of Claims : 4

(12) PATENT APPLICATION PUBLICATION

(21) Application
No.201911049970 A

(19) INDIA

(22) Date of filing of Application :04/12/2019

(43) Publication Date :
20/12/2019

(54) Title of the invention : WEIGHT DEPENDED VEHICLE CRUISE CONTROL SYSTEM

(51)
International :B60K0031040000,B60W0030140000,B60W0040105000,B60W0050120000,F16H0061210000
classification
(31) Priority
Document :NA
No
(32) Priority :NA
Date
(33) Name
of priority :NA
country
(86)
International
Application :NA
No :NA
Filing
Date
(87)
International : NA
Publication
No
(61) Patent
of Addition
to
Application :NA
Number :NA
Filing
Date
(62)
Divisional to
Application :NA
Number :NA
Filing
Date

(71)**Name of Applicant :**
1)Lovely Professional University
Address of Applicant :Lovely Professional University
Jalandhar-Delhi G.T. Road, Phagwara, Punjab-144 411, India
Punjab India
(72)**Name of Inventor :**
1)DUTTA, Adityam

(57) Abstract :

Disclosed is a weight depended vehicle cruise control system. The present invention reduces the speed of vehicle when speed exceeds the prescribed limit. This invention consists of a microcontroller wherein different slabs of weight are predefined by the manufacturer; and plurality of weight sensors measure the overall weight of the vehicle. As the vehicle exceeds its weight limit, consecutive slashing of the speed is initiated by the microcontroller, and even by pressing accelerator pedal again and again by the driver, the speed of the vehicle not increases.

No. of Pages : 10 No. of Claims : 5

(12) PATENT APPLICATION PUBLICATION

(21) Application
No.201911049972 A

(19) INDIA

(22) Date of filing of Application :04/12/2019

(43) Publication Date :
20/12/2019

(54) Title of the invention : A SYSTEM FOR SUSTAINABLE GLAZING

(51)
International :E06B0003670000,E06B0003540000,E06B0003660000,B32B0017100000,E06B0003580000
classification

(31) Priority
Document :NA
No

(32) Priority
Date :NA

(33) Name
of priority :NA
country

(86)
International
Application :NA
No :NA

Filing
Date

(87)
International
Publication : NA
No

(61) Patent
of Addition
to
Application :NA
Number :NA

Filing
Date

(62)
Divisional to

Application :NA
Number :NA

Filing
Date

(71)Name of Applicant :
**1)Lovely Professional
University**

Address of Applicant
:Lovely Professional
University Jalandhar-
Delhi G.T. Road,
Phagwara, Punjab-144
411, India Punjab India

(72)Name of Inventor :
**1)SHARMA,
Pushendra Kumar
2)DHIR, Amit Kumar**

(57) Abstract :

Disclosed is a system for sustainable glazing and controls the heat from sun rays in the summer and heat up the space from the windows in the winter. The present invention consists of a Double Glazing Unit frame; a Double Glazing Unit; plurality of pins for rotation; and plurality of clamps. The Double Glazing Unit is fitted into Double Glazing Unit window frame by using the pins and the clamps. The Double Glazing Unit consists of a glass 1, a glass 2 and a desiccant filled with argon gas. The glass 1 is made of toughened sun control glass pane and glass 2 is made of toughened clear glass; and the glass 1 is having thickness 5 mm and the glass 2 is having thickness 5 mm. This invention involves low cost and provides an energy efficient solution as it reduces the electrical consumption.

No. of Pages : 13 No. of Claims : 6

(12) PATENT APPLICATION PUBLICATION

(21) Application
No.201911049973 A

(19) INDIA

(22) Date of filing of Application :04/12/2019

(43) Publication Date :
20/12/2019

(54) Title of the invention : AI BASED CALORIE METER IN INTERGRATION TO FOOD SUPPLY BLOCKCHAIN

(51)
International :G01N0033020000,A61B0005000000,A63F0013400000,G06Q0040000000,G16H0040630000
classification
(31) Priority
Document :NA
No
(32) Priority :NA
Date
(33) Name
of priority :NA
country
(86)
International
Application :NA
No :NA
Filing
Date
(87)
International : NA
Publication
No
(61) Patent
of Addition
to
Application :NA
Number :NA
Filing
Date
(62)
Divisional to
Application :NA
Number :NA
Filing
Date

(71)**Name of Applicant**
:
**1)Lovely professional
University**
Address of
Applicant :Lovely
Professional University,
Jalandhar-Delhi GT
road Phagwara- 144411
Punjab India
(72)**Name of Inventor :**
**1)Sandeep Kumar
Arora**

(57) Abstract :

A system designed to measure the calorie content in the food using artificial intelligence calorie measuring technique, which is integrated to food supply block chain. The system displays the calorie content of the food along with the image on the LCD screen. The system is used to track the information about date of the food being processed and storage duration to the user.

No. of Pages : 10 No. of Claims : 8

(12) PATENT APPLICATION PUBLICATION

(21) Application
No.201911049974 A

(19) INDIA

(22) Date of filing of Application :04/12/2019

(43) Publication Date :
20/12/2019

(54) Title of the invention : GLUTEN FREE FERMENTED INFANT FOOD/BABY FOOD USING NUTRICEREALS

<p>(51) International :A23L0033000000,A21D0013040000,A23L0007152000,G06T0007593000,H01L0029788000 classification (31) Priority Document :NA No (32) Priority Date :NA (33) Name of priority :NA country (86) International Application :NA No :NA Filing Date (87) International Publication : NA No (61) Patent of Addition to Application :NA Number :NA Filing Date (62) Divisional to Application :NA Number :NA Filing Date</p>	<p>(71)Name of Applicant : 1)Lovely Professional University Address of Applicant :Lovely Professional University Jalandhar- Delhi G.T. Road, Phagwara, Punjab-144 411, India Punjab India (72)Name of Inventor : 1)RASANE, Prasad 2)MEHTA, Mohan Chandra 3)SINGH, Jyoti 4)KAUR, Sawinder</p>
--	---

(57) Abstract :

Utilization of nutriceal/coarse cereals like, oats, various millets, maize, etc. for formulation of a fermented nutriceal based infant/baby food. Using common germination and fermentation process for reducing the antinutrient factors responsible for rejection of nutriceals. Making a viable product to counter nutrient deficiency using local, low-cost produce.

No. of Pages : 11 No. of Claims : 6

(12) PATENT APPLICATION PUBLICATION

(21) Application
No.201911049976 A

(19) INDIA

(22) Date of filing of Application :04/12/2019

(43) Publication Date :
20/12/2019

(54) Title of the invention : A DEVICE TO REGROOVE THE SLIPPER SOLE

(51)
International :G06Q0030060000,A43B0003100000,H04L0029080000,F01N0003100000,G06Q0010000000
classification
(31) Priority
Document :NA
No
(32) Priority
Date :NA
(33) Name
of priority :NA
country
(86)
International
Application :NA
No :NA
Filing
Date
(87)
International
Publication : NA
No
(61) Patent
of Addition
to
Application :NA
Number :NA
Filing
Date
(62)
Divisional to
Application :NA
Number :NA
Filing
Date

(71)**Name of Applicant**
:
**1)Lovely professional
University**
Address of Applicant
:Lovely Professional
University, Jalandhar-
Delhi GT road
Phagwara- 144411
Punjab India
(72)**Name of Inventor :**
1)Cherry Bhargav
**2)Pradeep Kumar
Sharma**
3)Rajkumar Sarma
4)Jyotirmoy Pathak
5)Abhishek Kumar
6)Amit Sachdeva
7)Salman Khan

(57) Abstract :

A device to revive the grooves on the rubber sole of a pre-owned flip-flop/slipper, make them wearable again, by regenerating the gripping potential. The device is applicable for both types of rubber sole; hard sole and soft sole. This device provides a cost-effective solution to prevent the slippery accidents.

No. of Pages : 21 No. of Claims : 9

(12) PATENT APPLICATION PUBLICATION

(21) Application
No.201911050032 A

(19) INDIA

(22) Date of filing of Application :04/12/2019

(43) Publication Date :
20/12/2019

(54) Title of the invention : A NOVEL TRANS-DERMAL PATCH

(51)
International :A61K0009700000,A61K0009127000,A61K0009000000,A61M0005140000,A61M0039160000
classification

(31) Priority
Document :NA
No

(32) Priority
Date :NA

(33) Name
of priority :NA
country

(86)
International
Application :NA
No :NA

Filing
Date

(87)
International
Publication : NA
No

(61) Patent
of Addition
to
Application :NA
Number :NA

Filing
Date

(62)
Divisional to
Application :NA
Number :NA

Filing
Date

(71)Name of
Applicant :
**1)Lovely
Professional
University**
Address of
Applicant :Lovely
Professional University
Jalandhar-Delhi G.T.
Road, Phagwara,
Punjab-144 411, India
Punjab India

(72)Name of Inventor
:
**1)SUDHAKAR,
Kalvatala**
2)MISHRA, Vijay
**3)STANEKZAI,
Azimullah**

(57) Abstract :

The present invention discloses a novel trans-dermal patch containing niosome lipid vesicles embedded with bile salt for permeation of drug. The novel trans-dermal patch for sustain release of lornoxicam with enhanced permeation ability consists of niosomal suspension (2% v/v), propylene glycol (1% v/v), hydroxypropylmethyl cellulose (5% w/v), and distilled water (qs). The trans-dermal patch has higher entrapment capability as compared to conventional trans-dermal patch.

No. of Pages : 13 No. of Claims : 6

(12) PATENT APPLICATION PUBLICATION

(21) Application
No.201911050033 A

(19) INDIA

(22) Date of filing of Application :04/12/2019

(43) Publication Date :
20/12/2019

(54) Title of the invention : A NOVEL FORMULATION FOR THE MANAGEMENT OF UROLITHIASIS

(51)
International :A61K0045060000,A61K0009140000,A61K0009480000,A61K0031355000,A61K0047260000
classification
(31) Priority
Document :NA
No
(32) Priority :NA
Date
(33) Name
of priority :NA
country
(86)
International
Application :NA
No :NA
Filing
Date
(87)
International
Publication : NA
No
(61) Patent
of Addition
to
Application :NA
Number :NA
Filing
Date
(62)
Divisional to
Application :NA
Number :NA
Filing
Date

(71)**Name of Applicant**
:
**1)Lovely
Professional
University**
Address of
Applicant :Lovely
Professional University
Jalandhar-Delhi G.T.
Road, Phagwara,
Punjab-144 411, India
Punjab India
(72)**Name of Inventor**
:
**1)BAGHEL, Dileep
Singh**
2)SINGH, Saurabh
3)MITTAL, Amit

(57) Abstract :

The present invention discloses a novel formulation for the management of urolithiasis. The formulation consists of sphatika, surya kshar, apamarg kshar, gokshur extract, punarnava extract, acacia powder, and talc. The formulation reduces recurrence of stone episodes in urolithiasis and it can be formulated in various dosage forms.

No. of Pages : 12 No. of Claims : 3

(12) PATENT APPLICATION PUBLICATION

(21) Application
No.201911050034 A

(19) INDIA

(22) Date of filing of Application :04/12/2019

(43) Publication Date :
20/12/2019

(54) Title of the invention : A ROBOTIC SYSTEM FOR DOMESTIC USE

(51)
International :H04W0004800000,H04W0084180000,G06Q0020160000,G06N0003000000,G06Q0020320000
classification

(31) Priority
Document :NA
No

(32) Priority
Date :NA

(33) Name
of priority :NA
country

(86)
International
Application :NA
No :NA

Filing
Date

(87)
International
Publication : NA
No

(61) Patent
of Addition
to
Application :NA
Number :NA

Filing
Date

(62)
Divisional to
Application :NA
Number :NA

Filing
Date

(71)**Name of Applicant :**
1)Lovely Professional University
Address of Applicant :Lovely Professional University Jalandhar-Delhi G.T. Road, Phagwara, Punjab-144 411, India Punjab India

(72)**Name of Inventor :**
1)CAMBOW, Rameshwar
2)KHOSLA, Atul

(57) Abstract :

The present invention discloses an autonomous robotic system that is used for domestic purposes such as carrying heavy weights by controlling it with a bluetooth device with the help of a mobile application used in any android phone. The present invention consists of numerous hardware components, fabrication components and software components. In the present system, the coordinates of the rooms are stored and fed into the controller as per the requirement or the motors are controlled using any smartphone via the bluetooth interface. The present system is easy to operate once installed and is capable of carrying load up to 40kgs with convenience.

No. of Pages : 13 No. of Claims : 5

(12) PATENT APPLICATION PUBLICATION

(21) Application
No.201911050036 A

(19) INDIA

(22) Date of filing of Application :04/12/2019

(43) Publication Date :
20/12/2019

(54) Title of the invention : A METHOD T ENHANCE SOLUBILITY OF TELMISARTAN

(51)
International :A61K0031418400,A61K0009160000,C07D0235200000,A61K0049000000,A61K0038170000
classification

(31) Priority
Document :NA
No

(32) Priority
Date :NA

(33) Name
of priority :NA
country

(86)
International
Application :NA
No :NA

Filing
Date

(87)
International
Publication : NA
No

(61) Patent
of Addition
to

Application :NA
Number :NA

Filing
Date

(62)
Divisional to
Application :NA
Number :NA

Filing
Date

(71)Name of Applicant
:

**1)Lovely
Professional
University**
Address of
Applicant :Lovely
Professional University
Jalandhar-Delhi G.T.
Road, Phagwara,
Punjab-144 411, India
Punjab India

(72)Name of Inventor :

**1)BOSE, Sujit
2)MISHRA, Vijay
3)PATIAL, Swati**

(57) Abstract :

The present invention discloses a method to enhance solubility of telmisartan more particularly enhancement of solubility by making nanocrystals of telmisartan. The method consists of the steps of weighing an accurate amount of telmisartan, dissolving the telmisartan in an antisolvent, injecting the solution in to a second solution at 4 °C with rapid stirring at 1200 rpm followed by intense sonication and spray drying of the above mixture. The release from telmisartan nanocrystals is 70.07%.

No. of Pages : 17 No. of Claims : 4

(12) PATENT APPLICATION PUBLICATION

(21) Application
No.201911050037 A

(19) INDIA

(22) Date of filing of Application :04/12/2019

(43) Publication Date :
20/12/2019

(54) Title of the invention : A NOVEL PROCESS FOR WASTE WATER PURIFICATION

(51)
International :B82Y0030000000,H01M0004360000,A61K0008110000,H01M0004620000,C09D0005320000
classification

(31) Priority
Document :NA
No

(32) Priority
Date :NA

(33) Name
of priority :NA
country

(86)
International
Application :NA
No :NA

Filing
Date

(87)
International
Publication : NA
No

(61) Patent
of Addition
to
Application :NA
Number :NA

Filing
Date

(62)
Divisional to
Application :NA
Number :NA

Filing
Date

(71)**Name of Applicant :**
1)Lovely Professional University
Address of Applicant :Lovely Professional University Jalandhar-Delhi G.T. Road, Phagwara, Punjab-144 411, India Punjab India

(72)**Name of Inventor :**
1)ADHIKARI, Chandan

(57) Abstract :

A novel process for the degradation of dyes using photocatalysis. The process of making bismuth oxychloride coated iron oxide core shell nanoparticles. The process is cost effective and ecofriendly.

No. of Pages : 11 No. of Claims : 5

(12) PATENT APPLICATION PUBLICATION

(21) Application
No.201911050038 A

(19) INDIA

(22) Date of filing of Application :04/12/2019

(43) Publication Date :
20/12/2019

(54) Title of the invention : AUTOMATIC SYSTEM FOR MONITORING OF ELECTRIC POWER SUPPLY LINE AND FAULT LOCATION REPORTING

(51)
International :G01R0031080000,G08B0021180000,H04Q0009000000,G08G0001096700,H02H0007260000
classification

(31) Priority
Document :NA
No

(32) Priority :NA
Date

(33) Name
of priority :NA
country

(86)
International
Application :NA
No :NA

Filing
Date

(87)
International :NA
Publication
No

(61) Patent
of Addition
to
Application :NA
Number :NA

Filing
Date

(62)
Divisional to
Application :NA
Number :NA

Filing
Date

(71)Name of Applicant
:

**1)Lovely
professional University**
Address of
Applicant :Lovely
Professional University,
Jalandhar-Delhi GT
road Phagwara- 144411
Punjab India

(72)Name of Inventor :

**1)Dushyant Kumar
Singh
2)Kawaljeet Singh
3)Ashish Kumar
Singh**

(57) Abstract :

A system designed to detect the presence of electricity in the insulators of the electric poles and communicate to the base feeder, where an alert is generated when there is any fault in the line to the power station through IoT. This system provides no lag in the detection of problem in electric poles.

No. of Pages : 13 No. of Claims : 7

(12) PATENT APPLICATION PUBLICATION

(21) Application
No.201911050040 A

(19) INDIA

(22) Date of filing of Application :04/12/2019

(43) Publication Date :
20/12/2019

(54) Title of the invention : SMART WINDOW PANE CLEANING SYSTEM FOR HIGH RISE BUILDING

(51)
International :B67C0003000000,E06B0007280000,B05B0013040000,E06B0009240000,B05B0012000000
classification
(31) Priority
Document :NA
No
(32) Priority :NA
Date
(33) Name
of priority :NA
country
(86)
International
Application :NA
No :NA
Filing
Date
(87)
International
Publication : NA
No
(61) Patent
of Addition
to
Application :NA
Number :NA
Filing
Date
(62)
Divisional to
Application :NA
Number :NA
Filing
Date

(71)**Name of Applicant :**
**1)Lovely Professional
University**
Address of Applicant
:Lovely Professional
University Jalandhar-
Delhi G.T. Road,
Phagwara, Punjab-144
411, India Punjab India
(72)**Name of Inventor :**
1)SINGH, Rajesh
2)GEHLOT, Anita
3)GUPTA,
KmVaishnavi
4)DAS, Prabin Kumar
5)AKRAM, Shaik
Vaseem

(57) Abstract :

The smart window pane cleaning system is related to cleaning of the exterior wall windows. In the present system, the blowing control unit (100) unit consists of a microcontroller (104) which takes the input from the relay and operates the blowing unit associated with each window of the housing based on the algorithm defined. The RF (Radio frequency) modem (103) transfers the information to the server connected with the mobile application (102). The system is easily operated by just logging in to the application and setting the timer as per requirement.

No. of Pages : 15 No. of Claims : 5

(12) PATENT APPLICATION PUBLICATION

(21) Application
No.201911050066 A

(19) INDIA

(22) Date of filing of Application :05/12/2019

(43) Publication Date :
20/12/2019

(54) Title of the invention : AI and IoT based Monitoring System for Public Transport

(51)
International :H04L0029080000,G07B0015020000,G07C0011000000,G06N0005020000,G08B0021040000
classification
(31) Priority
Document :NA
No
(32) Priority :NA
Date
(33) Name
of priority :NA
country
(86)
International
Application :PCT//
No :01/01/1900
Filing
Date
(87)
International
Publication : NA
No
(61) Patent
of Addition
to
Application :NA
Number :NA
Filing
Date
(62)
Divisional to
Application :NA
Number :NA
Filing
Date

(71)**Name of Applicant**
:
**1)Dr Vijaypal Singh
Dhaka**
Address of
Applicant :Manipal
University Jaipur,
Dehmi Kalan, Near
GVK Toll Plaza, Jaipur
Rajasthan India
**2)Dr Manoj Sharma
3)Dr Geeta Rani**
(72)**Name of Inventor :**
**1)Dr Manoj Kumar
Sharma**
2)Geeta Rani
**3)Dr VijayPal Singh
Dhaka**

(57) Abstract :

The present disclosure relates to an Artificial Intelligence and Internet of Things (IoT) based Monitoring System for Public Transport (100), interchangeably will be called AI and IoT based Monitoring System (100), designed for (a) automating the ticketing system in public transport, (b) monitoring of passengers, (c) monitoring of activities of drivers and conductors, (d) resolving the problem of financial loss in public transport, (e) continuous monitoring for crime detection in a public transport system, and (f) Generating and sending notification. The AI and IoT based Monitoring System (100) can include at least one Face Capturing Unit (101), one Ticket Generating Unit (102), one Location Tracking Unit (103), one Ticket Scanning Unit (104), one Storage (105), one Data Processing Unit (106), one Monitoring Unit (107), and one Notification Generating Unit (108). Preferred Figure to accompany the abstract when published, see rule 13(7)(d): Figure 1.

No. of Pages : 24 No. of Claims : 25

(12) PATENT APPLICATION PUBLICATION

(21) Application
No.201911050246 A

(19) INDIA

(22) Date of filing of Application :05/12/2019

(43) Publication Date :
20/12/2019

(54) Title of the invention : A SYSTEM FOR MONITORING THE LECTURE QUALITY

(51)
International :G06F0003010000,A61B0005110000,G06K0009000000,A61B0005000000,A01K0029000000
classification

(31) Priority
Document :NA
No

(32) Priority
Date :NA

(33) Name
of priority :NA
country

(86)
International
Application :NA
No :NA

Filing
Date

(87)
International
Publication : NA
No

(61) Patent
of Addition
to
Application :NA
Number :NA

Filing
Date

(62)
Divisional to
Application :NA
Number :NA

Filing
Date

(71)**Name of Applicant**
:
**1)Lovely Professional
University**

Address of
Applicant :Lovely
Professional University
Jalandhar-Delhi G.T.
Road, Phagwara,
Punjab-144 411, India
Punjab India

(72)**Name of Inventor :**
**1)SINGH,
Ramandeep**

(57) Abstract :

Disclosed is a system for monitoring the lecture quality. This invention assesses the quality of the presentation of a lecture delivered by a presenter or teacher in front of an audience based on the analysis of the physical body language through video captured by camera and the voice analysis, and after data storage and video processing, the data is stored to the cloud. This invention uses artificial intelligence-based video analytics-based system which analyses the physical movements, postures, and gestures of the presenter or the teacher to quantify the delivery against predefined model for the movements. This invention provides the information whether the presenter is confident or not by monitoring the physical poses in terms of standing, hand movements, posture; and whether the presenter is confident or not by measuring the pitch, pace, consistency of the sound.

No. of Pages : 18 No. of Claims : 7

(12) PATENT APPLICATION PUBLICATION

(21) Application
No.201911050247 A

(19) INDIA

(22) Date of filing of Application :05/12/2019

(43) Publication Date :
20/12/2019

(54) Title of the invention : A POLY-HERBAL FORMULATION FOR TREATMENT OF UROLITHIASIS

(51)
International :A61K0009500000,A61K0047100000,A61K0031000000,A61K0009480000,A61K0009160000
classification
(31) Priority
Document :NA
No
(32) Priority :NA
Date
(33) Name
of priority :NA
country
(86)
International
Application :NA
No :NA
Filing
Date
(87)
International
Publication : NA
No
(61) Patent
of Addition
to
Application :NA
Number :NA
Filing
Date
(62)
Divisional to
Application :NA
Number :NA
Filing
Date

(71)**Name of Applicant**
:
**1)Lovely
Professional
University**
Address of
Applicant :Lovely
Professional University,
Jalandhar-Delhi GT
road Phagwara-
144411. Punjab India
(72)**Name of Inventor**
:
**1)Swati Sharma
2)Dileep Singh
Baghel
3)Saurabh Singh
4)Amit Mittal**

(57) Abstract :

The present invention discloses a polyherbal formulation for the treatment of urolithiasis. The formulation is made up of Trikantakadi kwath which has been incorporated in to various dosage forms. The formulation has increased shelf life.

No. of Pages : 18 No. of Claims : 2

(12) PATENT APPLICATION PUBLICATION

(21) Application
No.201911050248 A

(19) INDIA

(22) Date of filing of Application :05/12/2019

(43) Publication Date :
20/12/2019

(54) Title of the invention : A NOVEL FORMULATION OF SOLANUM XANTHOCARPUM FOR MYOCARDIAL INFRACTION

(51)
International :A61K0036810000,A61K0031551000,C08K0005130000,G11B0027320000,A61K0008970000
classification
(31) Priority
Document :NA
No
(32) Priority :NA
Date
(33) Name
of priority :NA
country
(86)
International
Application :NA
No :NA
Filing
Date
(87)
International
Publication : NA
No
(61) Patent
of Addition
to
Application :NA
Number :NA
Filing
Date
(62)
Divisional to
Application :NA
Number :NA
Filing
Date

(71)Name of Applicant
:
**1)Lovely
Professional
University**
Address of
Applicant :Lovely
Professional University
Jalandhar-Delhi G.T.
Road, Phagwara,
Punjab-144 411, India
Punjab India
(72)Name of Inventor :
**1)SAHU, Sanjeev
Kumar
2)SINGH, Ranjan
Kumar
3)WADHWA,
Pankaj**

(57) Abstract :

A novel process of making formulation of Solanum Xanthocarpum wherein the formulation includes extraction from solvent and conversion of extract to formulation.

No. of Pages : 8 No. of Claims : 5

(12) PATENT APPLICATION PUBLICATION

(21) Application
No.201911050249 A

(19) INDIA

(22) Date of filing of Application :05/12/2019

(43) Publication Date :
20/12/2019

(54) Title of the invention : NOVEL POLYHERBAL LOZENGES FOR MANAGEMENT OF STRESS

(51)
International :A61K0036810000,A61K0009000000,A61K0036480000,A61K0047260000,A61K0036280000
classification
(31) Priority
Document :NA
No
(32) Priority :NA
Date
(33) Name
of priority :NA
country
(86)
International
Application :NA
No :NA
Filing
Date
(87)
International
Publication : NA
No
(61) Patent
of Addition
to
Application :NA
Number :NA
Filing
Date
(62)
Divisional to
Application :NA
Number :NA
Filing
Date

(71)**Name of Applicant**
:
**1)Lovely
Professional
University**
Address of
Applicant :Lovely
Professional University,
Jalandhar-Delhi GT
road Phagwara-
144411. Punjab India
(72)**Name of Inventor**
:
**1)Amarjot Kaur
2)Saurabh Singh
3)Dileep Singh
Baghel**

(57) Abstract :

The present invention discloses a novel polyherbal lozenges for management of stress. The polyherbal formulation consists of dried aqueous extract of Ashwagandha, dried aqueous extract of Brahmi, dried aqueous extract of Shankpushpi, binders selected from the group consisting of starch, acacia and gelatin, magnesium stearate, talc, microcrystalline cellulose, sugar, and liquid glucose. The formulation is stable at normal storage condition.

No. of Pages : 28 No. of Claims : 3

(12) PATENT APPLICATION PUBLICATION

(21) Application
No.201911050250 A

(19) INDIA

(22) Date of filing of Application :05/12/2019

(43) Publication Date :
20/12/2019

(54) Title of the invention : A SMART DEVICE FOR COOKING

(51)
International :H01H0071100000,G06F0009445000,B29B0017000000,C12M0003000000,G06F0001160000
classification
(31) Priority
Document :NA
No
(32) Priority
Date :NA
(33) Name
of priority :NA
country
(86)
International
Application :NA
No :NA
Filing
Date
(87)
International
Publication : NA
No
(61) Patent
of Addition
to
Application :NA
Number :NA
Filing
Date
(62)
Divisional to
Application :NA
Number :NA
Filing
Date

(71)**Name of Applicant**
:
**1)Lovely Professional
University**
Address of Applicant
:Lovely Professional
University Jalandhar-
Delhi G.T. Road,
Phagwara, Punjab-144
411, India Punjab India
(72)**Name of Inventor :**
1)SHARMA,
Pushpendra Kumar
2)SHUKLA, Bishnu
Kant
3)SINGH, Vishaldeep
4)PANDEY,
Prashant Kumar

(57) Abstract :

A multipurpose device for cooking which consists of plurality of circular disc connected to each other guarded with a frame. The said device is detachable and can be used anywhere. The said device can be used both with and without lid.

No. of Pages : 10 No. of Claims : 5

(12) PATENT APPLICATION PUBLICATION

(21) Application
No.201911050252 A

(19) INDIA

(22) Date of filing of Application :05/12/2019

(43) Publication Date :
20/12/2019

(54) Title of the invention : A HERBAL FORMULATION FOR ANALGESIC AND WOUND HEALING ACTIVITY

(51)
International :A61K0036284000,A61K0047260000,C12N0015640000,A61K0031232000,G11C0029120000
classification

(31) Priority
Document :NA
No

(32) Priority
Date :NA

(33) Name
of priority :NA
country

(86)
International
Application :NA
No :NA

Filing
Date

(87)
International
Publication : NA

No
(61) Patent
of Addition
to

Application :NA
Number :NA

Filing
Date

(62)
Divisional to

Application :NA
Number :NA

Filing
Date

(71)Name of Applicant

:
**1)Lovely
Professional
University**

Address of
Applicant :Lovely
Professional University
Jalandhar-Delhi G.T.
Road, Phagwara,
Punjab-144 411, India
Punjab India

(72)Name of Inventor :

**1)KUMARI, Sweta
2)BAGHEL, Dileep
Singh
3)SINGH, Saurabh
4)MITTAL, Amit**

(57) Abstract :

The present invention discloses a novel herbal formulation for analgesic and wound healing activity. The present invention incorporates panchguna taila in various dosage form to overcome some of the limitations associated with the use of said taila. The formulation is stable and lack stickiness and don't stain clothes.

No. of Pages : 16 No. of Claims : 8

(12) PATENT APPLICATION PUBLICATION

(21) Application
No.201911050253 A

(19) INDIA

(22) Date of filing of Application :05/12/2019

(43) Publication Date :
20/12/2019

(54) Title of the invention : A NOVEL PROCESS OF MAKING PHYTOSOMAL GEL FROM PONGAMIA PINNATA

(51)
International :A61Q0019000000,A61K0008040000,A61K0045060000,A61K0009000000,D21H0021100000
classification
(31) Priority
Document :NA
No
(32) Priority :NA
Date
(33) Name
of priority :NA
country
(86)
International
Application :NA
No :NA
Filing
Date
(87)
International : NA
Publication
No
(61) Patent
of Addition
to
Application :NA
Number :NA
Filing
Date
(62)
Divisional to
Application :NA
Number :NA
Filing
Date

(71)**Name of Applicant**
:
**1)Lovely
Professional
University**
Address of
Applicant :Lovely
Professional University,
Jalandhar-Delhi GT
road Phagwara-
144411. Punjab India
(72)**Name of Inventor**
:
**1)Manpreet Kaur
2)Saurabh Singh
3)Dileep Singh
Baghel**

(57) Abstract :

A novel process of making phytosomal gel formulation wherein the process includes, extraction, phytosomal preparation, addition of additives and storing at lower temperature. The process is cost effective and advantageous.

No. of Pages : 10 No. of Claims : 5

(12) PATENT APPLICATION PUBLICATION

(21) Application
No.201911050254 A

(19) INDIA

(22) Date of filing of Application :05/12/2019

(43) Publication Date :
20/12/2019

(54) Title of the invention : NOVEL FORMULATION BASED ON COLON TARGETED DELIVERY SYSTEM

(51)
International :A61K0031635000,A61K0009160000,A61K0009000000,A61K0009500000,A61K0009200000
classification
(31) Priority
Document :NA
No
(32) Priority :NA
Date
(33) Name
of priority :NA
country
(86)
International
Application :NA
No :NA
Filing
Date
(87)
International : NA
Publication
No
(61) Patent
of Addition
to
Application :NA
Number :NA
Filing
Date
(62)
Divisional to
Application :NA
Number :NA
Filing
Date

(71)**Name of Applicant**
:
**1)Lovely
Professional
University**
Address of
Applicant :Lovely
Professional University,
Jalandhar-Delhi GT
road Phagwara-
144411. Punjab India
(72)**Name of Inventor**
:
**1)Adil Hussain
Malik
2)Bimlesh Kumar
3)Sachin Kumar
Singh
4)Monica Gulati
5)Narendra Kumar
Pandey**

(57) Abstract :

The present invention discloses a novel formulation based on colon targeted drug delivery system. The novel formulation for colon targeted delivery consists of sulfasalazine (40%> by weight), guar gum (40%> by weight), microcrystalline cellulose PH 101 (18%> by weight) and talc (2% by weight). The formulation is stable and effective in the treatment of ulcerative colitis.

No. of Pages : 25 No. of Claims : 4

(12) PATENT APPLICATION PUBLICATION

(21) Application
No.201911050259 A

(19) INDIA

(22) Date of filing of Application :05/12/2019

(43) Publication Date :
20/12/2019

(54) Title of the invention : CLIP-BASED WELL CREATOR FOR AGAROSE GELS

(51)
International :G01N0027447000,A61B0017064000,B43M0099000000,A61B0017300000,A61L0027520000
classification
(31) Priority
Document :NA
No
(32) Priority :NA
Date
(33) Name
of priority :NA
country
(86)
International
Application :NA
No :NA
Filing
Date
(87)
International
Publication : NA
No
(61) Patent
of Addition
to
Application :NA
Number :NA
Filing
Date
(62)
Divisional to
Application :NA
Number :NA
Filing
Date

(71)**Name of Applicant**
:
**1)Lovely
Professional
University**
Address of
Applicant :Lovely
Professional University
Jalandhar-Delhi G.T.
Road, Phagwara,
Punjab-144 411, India
Punjab India
(72)**Name of Inventor :**
**1)CHOPRA, Chirag
2)SINGH, Reena
3)DHANJAL,
Daljeet Singh**

(57) Abstract :

The present invention describes a clip-based well creator for agarose gels that creates wells in an already solidified agarose gel. The present invention consists of a cutter head (101), a spring system for core (102), a central core (103), a clip holder (104) and a cover (105). The present invention has sharp blade-like clips, which are sized to the correct dimension and are used for creating wells in a pre-solidified agarose gel.

No. of Pages : 14 No. of Claims : 8

(12) PATENT APPLICATION PUBLICATION

(21) Application
No.201911050262 A

(19) INDIA

(22) Date of filing of Application :05/12/2019

(43) Publication Date :
20/12/2019

(54) Title of the invention : CHEMICAL FREE BIODEGRADABLE SANITARY NAPKIN

(51)
International :A61F0013472000,A61F0013150000,D04H0013000000,A61F0013840000,A61F0013514000
classification

(31) Priority
Document :NA
No

(32) Priority
Date :NA

(33) Name
of priority :NA
country

(86)
International
Application :NA
No :NA

Filing
Date

(87)
International
Publication : NA
No

(61) Patent
of Addition
to
Application :NA
Number :NA

Filing
Date

(62)
Divisional to
Application :NA
Number :NA

Filing
Date

(71)**Name of Applicant :**
**1)Lovely Professional
University**

Address of Applicant
:Lovely Professional
University, Jalandhar-
Delhi GT road Phagwara-
144411. Punjab India

(72)**Name of Inventor :**
1)Monica Gulati
**2)Sachin Kumar
Singh**
3)Renuka
4)Rubiya Khursheed

(57) Abstract :

The present invention discloses a chemical free biodegradable sanitary napkin. The sanitary napkin consists of a first layer which is used for giving soft contact to skin, a second layer which contain probiotic as absorbent material, a third layer which forms gel after absorbing liquid and a fourth layer which is made of absorbent material previously soaked and dried in solution of a peptide. The sanitary napkin is biodegradable and can be flushed easily without any blockage problem.

No. of Pages : 12 No. of Claims : 3

(12) PATENT APPLICATION PUBLICATION

(21) Application
No.201911050263 A

(19) INDIA

(22) Date of filing of Application :05/12/2019

(43) Publication Date :
20/12/2019

(54) Title of the invention : TEMPERATURE CONTROLLED SMART CEILING FAN SYNCHRONIZED WITH HUMIDIFIER AND DE-HUMIDIFIER

(51)
International :F04D0025080000,F24F0011300000,F24F0011560000,F24F0006000000,F24F0011000000
classification
(31) Priority
Document :NA
No
(32) Priority :NA
Date
(33) Name
of priority :NA
country
(86)
International
Application :NA
No :NA
Filing
Date
(87)
International : NA
Publication
No
(61) Patent
of Addition
to
Application :NA
Number :NA
Filing
Date
(62)
Divisional to
Application :NA
Number :NA
Filing
Date

(71)**Name of Applicant :**
**1)Lovely Professional
University**
Address of Applicant
:Lovely Professional
University, Delhi Jalandhar
GT road Phagwara-
144411. Punjab India
(72)**Name of Inventor :**
**1)Dushyant Kumar
Singh**
2)P. Raja
3)Himani Jerath

(57) Abstract :

Disclosed is a temperature controlled smart ceiling fan synchronized with humidifier and de-humidifier. The present invention consists of a master unit installed with ceiling fan; a slave unit in humidifier; a slave unit in de-humidifier; a temperature and humidity sensor in the master unit; a wireless connecting media. This invention uses the temperature and humidity sensor in master unit installed in the ceiling fan to measure the temperature and humidity of the room and if temperature is not equal to threshold level then controls the fan speed. If humidity is less than the threshold then signal is wirelessly transmitted to humidifier to activate otherwise de-humidifier activates to make the room environment pleasant. This invention is easy to install and easy to operate as no human intervention is involved to control the fan speed.

No. of Pages : 13 No. of Claims : 6

(12) PATENT APPLICATION PUBLICATION

(21) Application
No.201911050265 A

(19) INDIA

(22) Date of filing of Application :05/12/2019

(43) Publication Date :
20/12/2019

(54) Title of the invention : A REMOTE CONTROLLED SUNLIGHT PROTECTION SYSTEM FOR CARS

<p>(51) International :A47H0007020000,E06B0009680000,A47H0005060000,A47H0001102000,A47H0005020000 classification (31) Priority Document :NA No (32) Priority :NA Date (33) Name of priority :NA country (86) International Application :NA No :NA Filing Date (87) International Publication : NA No (61) Patent of Addition to Application :NA Number :NA Filing Date (62) Divisional to Application :NA Number :NA Filing Date</p>	<p>(71)Name of Applicant : 1)Lovely Professional University Address of Applicant :Lovely Professional University, Delhi Jalandhar GT road Phagwara- 144411. Punjab India (72)Name of Inventor : 1)Rameshwar Cambow 2)Atul Khosla 3)Arafath Baig</p>
--	---

(57) Abstract :

The present invention discloses a remote controlled system which is mounted on the inside of the car to protect against sunlight. The system consists of bearings to support the curtain rod (1), a curtain rod 1 (2), a motor (3), a motor controller with RF receiver (4), a battery (5), a curtain frame (pelmet) (6), a curtain cloth (7), a curtain rod 2 (reciprocating rod attached to other end of curtain) (8), limits of stroke (9). In the present invention, the motor (3) is connected to two of the relays to operate in two way directions and rotates the pulley like mechanism for which the cloth is attached and thus the opening and closing of the cloth works by the motor (3) rotating in forward and backward direction.

No. of Pages : 14 No. of Claims : 6

(12) PATENT APPLICATION PUBLICATION

(21) Application
No.201911050266 A

(19) INDIA

(22) Date of filing of Application :05/12/2019

(43) Publication Date :
20/12/2019

(54) Title of the invention : AN ANALYSIS ON TECHNICAL EFFICIENCY OF PUBLIC HOSPITAL IN ASSOCIATION AS MODERATOR TO CUSTOMER SATISFACTION

(51)
International :A23L0033000000,G16H0040200000,G06Q0030020000,G06Q0010060000,A61B0006000000
classification

(31) Priority
Document :NA
No

(32) Priority :NA
Date

(33) Name
of priority :NA
country

(86)
International
Application :NA
No :NA

Filing

Date
(87)

International :NA
Publication

No
(61) Patent
of Addition

to :NA
Application :NA
Number

Filing

Date
(62)

Divisional to
Application :NA

Number :NA
Filing

Date

(71)Name of Applicant :

**1)Lovely
Professional University**

Address of
Applicant :Lovely
Professional University,
Delhi Jalandhar GT road
Phagwara- 144411.

Punjab India

(72)Name of Inventor :

**1)Pritpal Singh
2)Mohd. Farhan**

(57) Abstract :

A method to analysis of the efficiency in the hospital and provide an insight to the hospital management, also set benchmark for input required in hospitals by resolving operational problem by using Data Envelopment Analysis(DEA) technique in association with improved customer satisfaction.

No. of Pages : 14 No. of Claims : 8

(12) PATENT APPLICATION PUBLICATION

(21) Application
No.201911050267 A

(19) INDIA

(22) Date of filing of Application :05/12/2019

(43) Publication Date :
20/12/2019

(54) Title of the invention : A PORTABLE GROOMING PEN

(51)
International :A45C0011000000,A01K0013000000,A45C0013020000,A61Q0011000000,A45D0044180000
classification
(31) Priority
Document :NA
No
(32) Priority :NA
Date
(33) Name
of priority :NA
country
(86)
International
Application :NA
No :NA
Filing
Date
(87)
International : NA
Publication
No
(61) Patent
of Addition
to
Application :NA
Number :NA
Filing
Date
(62)
Divisional to
Application :NA
Number :NA
Filing
Date

(71)**Name of Applicant**
:
**1)Lovely
Professional
University**
Address of
Applicant :Lovely
Professional University
Jalandhar-Delhi G.T.
Road, Phagwara,
Punjab-144 411, India
Punjab India
(72)**Name of Inventor :**
**1)SINGH,Mandeep
2)CHOUDHURY,
Ruhul Amin
3)KAMALGURU,
Rakesh
4)SINGH ,
Harpinder**

(57) Abstract :

A modular portable grooming pen, a regular grooming kit with a utility embodied with a toothbrush, a tooth paste dispenser and a sanitizing kit. The portable grooming pen kit provides a compact solution for carrying grooming kit with utility pen.

No. of Pages : 10 No. of Claims : 6

(12) PATENT APPLICATION PUBLICATION

(21) Application
No.201911050289 A

(19) INDIA

(22) Date of filing of Application :05/12/2019

(43) Publication Date :
20/12/2019

(54) Title of the invention : A NOVEL PROCESS OF MAKING QUINOLINE BASED CYANOHYDRAZONE DERIVATIVES

(51)
International :C07D0215260000,A01N0043420000,C07D0215540000,C07D0215420000,C07D0401060000
classification
(31) Priority
Document :NA
No
(32) Priority :NA
Date
(33) Name
of priority :NA
country
(86)
International
Application :NA
No :NA
Filing
Date
(87)
International : NA
Publication
No
(61) Patent
of Addition
to :NA
Application :NA
Number :NA
Filing
Date
(62)
Divisional to
Application :NA
Number :NA
Filing
Date

(71)Name of Applicant
:
**1)Lovely Professional
University**
Address of
Applicant :Lovely
Professional University
Jalandhar-Delhi G.T.
Road, Phagwara,
Punjab-144 411, India
Punjab India
(72)Name of Inventor :
**1)GOVINDAIAH,
Pilli**

(57) Abstract :

A novel process of making Quinoline based Cyanohydrazone Derivatives wherein the process includes reaction of 4-hydroxyquinoline (1) and phosphorus oxychloride which yields acylated quinoline (2), Then the acylated quinoline reacts with cyanoacetohydrazide, that is stirred for 3hrs at 60°C in presence of ethanol and acetic acid the mixture which yields hydrazide substituted product (3). Further the hydrazide substituted quinoline compound reacts with different aromatic aldehydes in presence of piperidine base, the reaction undergo reflux for 3hrs which yields final compound (4).

No. of Pages : 9 No. of Claims : 1

(12) PATENT APPLICATION PUBLICATION

(21) Application
No.201911050290 A

(19) INDIA

(22) Date of filing of Application :05/12/2019

(43) Publication Date :
20/12/2019

(54) Title of the invention : A SYSTEM TO TRACK THE CUSTOMER INTEREST IN RETAIL CLOTHING

(51)
International :G06Q0030060000,G06F0016953700,G06Q0030020000,C07D0309120000,C07F0009240000
classification
(31) Priority
Document :NA
No
(32) Priority :NA
Date
(33) Name
of priority :NA
country
(86)
International
Application :NA
No :NA
Filing
Date
(87)
International
Publication : NA
No
(61) Patent
of Addition
to
Application :NA
Number :NA
Filing
Date
(62)
Divisional to
Application :NA
Number :NA
Filing
Date

(71)**Name of Applicant**
:
**1)Lovely Professional
University**
Address of Applicant
:Lovely Professional
University Jalandhar-
Delhi G.T. Road,
Phagwara, Punjab-144
411, India Punjab India
(72)**Name of Inventor :**
**1)SINGH,
Ramandeep**

(57) Abstract :

A system to track the customers clothing interest in the retail shopping and collect the database entries based upon the clothing items picked by the customer in the shop. This system helps to analyze the customer choice trends in the clothing items and give insight to the shopkeeper to rearrange the items at the prime location in the store. The stored data in the database management related to the clothing hanger removals are analyzed through the graphs and charts to make business.

No. of Pages : 19 No. of Claims : 10

(12) PATENT APPLICATION PUBLICATION

(21) Application
No.201911050291 A

(19) INDIA

(22) Date of filing of Application :05/12/2019

(43) Publication Date :
20/12/2019

(54) Title of the invention : A NOVEL PROCESS OF MAKING BIGUANIDINE DERIVATIVES

(51)
International :C12J0001040000,C07C0201120000,C12P0007100000,C07C0279260000,C07C0041260000
classification
(31) Priority
Document :NA
No
(32) Priority :NA
Date
(33) Name
of priority :NA
country
(86)
International
Application :NA
No :NA
Filing
Date
(87)
International
Publication : NA
No
(61) Patent
of Addition
to
Application :NA
Number :NA
Filing
Date
(62)
Divisional to
Application :NA
Number :NA
Filing
Date

(71)**Name of Applicant :**
**1)Lovely Professional
University**
Address of Applicant
:Lovely Professional
University Jalandhar-
Delhi G.T. Road,
Phagwara, Punjab-144
411, India Punjab India
(72)**Name of Inventor :**
1)MOHD, Sharfuddin

(57) Abstract :

A novel process of making biguanide Derivatives wherein the process includes in first step when phloroglucinol (1) undergoes reflux presence of acetic acid and phosphorus oxychloride which yields acylated phloroglucinol (2), the process is known as acylation. Then the acylated phloroglucinol reacts with biguanide, that is stirred for 3hrs at 60°C in presence of ethanol and acetic acid the mixture which yields biguanide substituted phloroglucinol product is formed (4). Further the biguanide substituted phloroglucinol compound reacts with different aromatic aldehydes in presence of ethanol and trifluoroacetic acid, the reaction undergo reflux for 3hrs. which yields final compound (5a-c).

No. of Pages : 10 No. of Claims : 1

(12) PATENT APPLICATION PUBLICATION

(21) Application
No.201911050380 A

(19) INDIA

(22) Date of filing of Application :06/12/2019

(43) Publication Date :
20/12/2019

(54) Title of the invention : PROTECTIVE LAYER FOR MICROWAVE METAMATERIAL ABSORBERS AND METHOD THEREOF

(51)
International :H01Q0015000000,B32B0027080000,G02B0001000000,C09D0175040000,C08G0018610000
classification

(31) Priority
Document :NA
No

(32) Priority :NA
Date

(33) Name
of priority :NA
country

(86)
International
Application :NA
No :NA

Filing
Date

(87)
International : NA
Publication
No

(61) Patent
of Addition
to
Application :NA
Number :NA
Filing

Date

(62)
Divisional to
Application :NA
Number :NA

Filing
Date

(71)Name of Applicant :

**1)Indian Institute of
Technology Kanpur**

Address of
Applicant :Dean,
Research &
Development, Room
Number 151, Faculty
Building, Post Office:
IIT Kanpur, Kanpur-
208016, Uttar Pradesh,
India Uttar Pradesh
India

(72)Name of Inventor :

1)Kajal Chaudhary

2)Janakarajan

Ramkumar

3)S. Anantha

Ramakrishna

4)Kumar Vaibhav

Srivastava

5)Praveen C.

Ramamurthy

(57) Abstract :

The present invention relates to the field of protective coatings. The Invention in particular provides transparent protective coatings for ITO-PET based microwave metamaterial and its method of preparation.

No. of Pages : 18 No. of Claims : 10

(12) PATENT APPLICATION PUBLICATION

(21) Application
No.201911050416 A

(19) INDIA

(22) Date of filing of Application :06/12/2019

(43) Publication Date :
20/12/2019

(54) Title of the invention : A SMART TUBE LIGHT FLAPPER

(51)
International :H04W0004160000,G06F0009460000,G06F0011360000,A01K0001035000,G21C0013067000
classification

(31) Priority
Document :NA
No

(32) Priority
Date :NA

(33) Name
of priority :NA
country

(86)
International
Application :NA
No :NA

Filing
Date

(87)
International
Publication : NA
No

(61) Patent
of Addition
to
Application :NA
Number :NA

Filing
Date

(62)
Divisional to
Application :NA
Number :NA

Filing
Date

(71)Name of Applicant
:

**1)Lovely
Professional University**

Address of
Applicant :Lovely
Professional University,
Jalandhar-Delhi G.T.
Road, Phagwara
144411, Punjab, India
Punjab India

(72)Name of Inventor :

**1)Mandeep Singh
2)Sorabh Lakhnarpal
3)Manish Kotni
4)Ruhul Amin
Choudhury**

(57) Abstract :

A device with an external plug attached to the tube light which controls the glare of the light reflected, which is easily adjusted remotely through mobile application as per the user requirement. The flapper is laminated with reflection strip to divert the light reflection as the user requirement.

No. of Pages : 13 No. of Claims : 6

(12) PATENT APPLICATION PUBLICATION

(21) Application
No.201911050417 A

(19) INDIA

(22) Date of filing of Application :06/12/2019

(43) Publication Date :
20/12/2019

(54) Title of the invention : A SYSTEM FOR SMART AND SECURE FOOD DELIVERY

(51)
International :G07C0009000000,H04W0004140000,A47G0029140000,H04L0029060000,H04L0009320000
classification

(31) Priority
Document :NA
No

(32) Priority
Date :NA

(33) Name
of priority :NA
country

(86)
International
Application :NA
No :NA

Filing
Date

(87)
International
Publication : NA
No

(61) Patent
of Addition
to
Application :NA
Number :NA

Filing
Date

(62)
Divisional to

Application :NA
Number :NA

Filing
Date

(71)Name of Applicant
:

**1)Lovely
Professional
University**
Address of
Applicant :Lovely
Professional University,
Delhi Jalandhar GT
road Phagwara- 144411.
Punjab India

(72)Name of Inventor :
1)Ramandeep Singh

(57) Abstract :

Disclosed is a system for smart and secure food delivery. The present invention consists of a power source; a digital lock controller with OTP (One Time Password) validation service; a microcontroller; a weighing sensor service; a location service; and an internet and SMS service. This invention is equipped with multiple compartments having either a single access door or individual access doors secure with an electronic lock that is opened by input of predefined locking/unlocking code in order to open the locked compartment. The present invention provides to track the movement of the food delivery box throughout the journey using the customer mobile application installed on the customer smart phone. The present invention provides a solution which ensure that the food items are delivered without any tempering.

No. of Pages : 20 No. of Claims : 10

(12) PATENT APPLICATION PUBLICATION

(21) Application
No.201911050418 A

(19) INDIA

(22) Date of filing of Application :06/12/2019

(43) Publication Date :
20/12/2019

(54) Title of the invention : A SYSTEM FOR TRACKING THE ON SEAT PRESENCE OF EMPLOYEES

(51)
International :B60N0002000000,G08B0029180000,G01G0019414000,H05B0033080000,H05B0037020000
classification
(31) Priority
Document :NA
No
(32) Priority :NA
Date
(33) Name
of priority :NA
country
(86)
International
Application :NA
No :NA
Filing
Date
(87)
International : NA
Publication
No
(61) Patent
of Addition
to
Application :NA
Number :NA
Filing
Date
(62)
Divisional to
Application :NA
Number :NA
Filing
Date

(71)**Name of Applicant**
:
**1)Lovely Professional
University**
Address of
Applicant :Lovely
Professional University,
Delhi Jalandhar GT road
Phagwara- 144411.
Punjab India
(72)**Name of Inventor :**
1)Ramandeep Singh

(57) Abstract :

The present invention discloses a system for tracking the on seat presence of the person. The present system consists of a microcontroller, a weight sensor, an ultrasonic sensor, a pressure sensor, a wireless communication interface, mobile application and a power source. In the present system, the weight measurement sensor or the ultrasonic sensor is triggered when chair detects a person on it and the microcontroller transfers the data to the central system to update the database status for that particular chair.

No. of Pages : 8 No. of Claims : 6

(12) PATENT APPLICATION PUBLICATION

(21) Application
No.201911050420 A

(19) INDIA

(22) Date of filing of Application :06/12/2019

(43) Publication Date :
20/12/2019

(54) Title of the invention : PHYTOSOMAL FORMULATION OF PHYLLANTHUS NIRURI FOR MANAGEMENT OF DIABETES

(51)
International :A61K0009000000,A61K0047240000,A61K0031568500,A23L0002390000,A61K0009480000
classification

(31) Priority
Document :NA
No

(32) Priority :NA
Date

(33) Name
of priority :NA
country

(86)
International
Application :NA
No :NA

Filing
Date

(87)
International : NA
Publication
No

(61) Patent
of Addition
to
Application :NA
Number :NA

Filing
Date

(62)
Divisional to
Application :NA
Number :NA

Filing
Date

(71)Name of Applicant
:

**1)Lovely
Professional
University**
Address of
Applicant :Lovely
Professional University,
Jalandhar-Delhi GT
road Phagwara- 144411.
Punjab India

(72)Name of Inventor :

**1)Manish Vyas
2)Gopal Lal Khatik
3)Harpreet Kaur
4)Saurabh Satija
5)Vijay Mishra
6)Navneet Khurana**

(57) Abstract :

The present invention discloses a phytosomal formulation for management of diabetes. The phytosomal formulation is prepared using soya lecithin and cholesterol. The formulation has enhances efficacy and bioavailability.

No. of Pages : 9 No. of Claims : 6

(12) PATENT APPLICATION PUBLICATION

(21) Application
No.201911050421 A

(19) INDIA

(22) Date of filing of Application :06/12/2019

(43) Publication Date :
20/12/2019

(54) Title of the invention : A SMART BELT FOR CHILDREN TO PROVIDE SECURITY

(51)
International :G06F0021620000,G08B0025010000,G06Q0020100000,G08G0001000000,H04M0011040000
classification

(31) Priority
Document :NA
No

(32) Priority
Date :NA

(33) Name
of priority :NA
country

(86)
International
Application :NA
No :NA

Filing
Date

(87)
International
Publication : NA
No

(61) Patent
of Addition
to

Application :NA
Number :NA

Filing
Date

(62)
Divisional to
Application :NA

Number :NA

Filing
Date

(71)Name of Applicant
:

**1)Lovely
Professional
University**
Address of
Applicant :Lovely
Professional University,
Delhi Jalandhar GT
road Phagwara- 144411.
Punjab India

(72)Name of Inventor :

**1)Girish Kumar
2)Jasmine Kaur
3)Himani Jerath
4)Ajay Kumar
Shriram Kushwaha
5)Balraj Kumar**

(57) Abstract :

Disclosed is a smart belt for children to provide security. The present invention consists of a sensor; a push button; a processor board; a GPS (Global Positioning Signal); a GSM (Global System for Mobile Communication); and the GSM and the GPS transfer information regarding location of the children to parents/police in case of emergency, this invention uses sensor integrated with the smart belt senses the reading and if value is greater than threshold value then message regarding location is transmitted to the parents/police; and if push button is pressed by the child then information regarding location of the child is forwarded to the parents/police. This invention provides a cost-effective solution and is having light weight.

No. of Pages : 12 No. of Claims : 5

(12) PATENT APPLICATION PUBLICATION

(21) Application
No.201911050422 A

(19) INDIA

(22) Date of filing of Application :06/12/2019

(43) Publication Date :
20/12/2019

(54) Title of the invention : A SYSTEM OF IMAGE PROCESSING BASED CONTROLLER FOR E-VEHICLE FOR SPEED CONTROL

(51)
International :G06K0009000000,B60W0030140000,G05D0001020000,B60W0010040000,B60K0031000000
classification
(31) Priority
Document :NA
No
(32) Priority :NA
Date
(33) Name
of priority :NA
country
(86)
International
Application :NA
No :NA
Filing
Date
(87)
International : NA
Publication
No
(61) Patent
of Addition
to
Application :NA
Number :NA
Filing
Date
(62)
Divisional to
Application :NA
Number :NA
Filing
Date

(71)**Name of Applicant :**
1)Lovely Professional University
Address of Applicant :Lovely Professional University, Delhi Jalandhar GT road Phagwara- 144411. Punjab India
(72)**Name of Inventor :**
1)SINGH, Rajesh
2)Gehlot, Anita
3)Rathour, Navjot
4)Prajapat, Mahesh Kumar
5)Verma, Yogesh Kumar
6)Tripathi, Suman Lata
7)Prakash, Kavuri Bhanu

(57) Abstract :

The present invention provides smart Controller for E-Vehicle which can help to control the speed of e-vehicles. This device will have a camera which will detect the objects and speed sign boards which will be processed using image processing and later it will identify the speed on the signal board and triggers the speed controller which will accelerate and deaccelerate the speed of e-vehicle and object detection will help to run the vehicle in control while controlling the speed of vehicle while functioning.

No. of Pages : 11 No. of Claims : 4

(12) PATENT APPLICATION PUBLICATION

(21) Application
No.201911050423 A

(19) INDIA

(22) Date of filing of Application :06/12/2019

(43) Publication Date :
20/12/2019

(54) Title of the invention : A SYSTEM FOR ANTI-DROWNING SYSTEM IN PUBLIC SWIMMING POOLS

<p>(51) International :G08B0021080000,E04H0004140000,G06F0021620000,H04W0012100000,H04W0004160000 classification (31) Priority Document :NA No (32) Priority :NA Date (33) Name of priority :NA country (86) International Application :NA No :NA Filing Date (87) International Publication : NA No (61) Patent of Addition to Application :NA Number :NA Filing Date (62) Divisional to Application :NA Number :NA Filing Date</p>	<p>(71)Name of Applicant : 1)Lovely Professional University Address of Applicant :Lovely Professional University, Delhi Jalandhar GT road Phagwara- 144411. Punjab India (72)Name of Inventor : 1)Ramandeep Singh</p>
--	---

(57) Abstract :

A system to prevent the user from drowning in a public swimming , through a bracelet in which, the heart variation and GPS location is used to track the user who needs help to be rescued from the swimming pool.

No. of Pages : 11 No. of Claims : 8

(12) PATENT APPLICATION PUBLICATION

(21) Application
No.201911050424 A

(19) INDIA

(22) Date of filing of Application :06/12/2019

(43) Publication Date :
20/12/2019

(54) Title of the invention : A LONG RANGE OPERATION COMMUNICATION NETWORK SYSTEM FOR COAL MINE WORKER SAFETY

(51)
International :C02F0011040000,G06N0003080000,E21F0017180000,G01S0005020000,G08B0025100000
classification

(31) Priority
Document :NA
No

(32) Priority :NA
Date

(33) Name
of priority :NA
country

(86)
International
Application :NA
No :NA

Filing
Date

(87)
International : NA
Publication
No

(61) Patent
of Addition
to
Application :NA
Number :NA
Filing

Date

(62)
Divisional to
Application :NA
Number :NA
Filing

Date

(71)Name of Applicant :
**1)Lovely Professional
University**

Address of Applicant
:Lovely Professional
University, Delhi
Jalandhar GT road
Phagwara- 144411.
Punjab India

(72)Name of Inventor :

**1)SINGH, Rajesh
2)Gehlot, Anita
3)Akram, Shaik
Vaseem
4)Gupta, Lovi Raj**

(57) Abstract :

The present invention relates to a Long Range OperationCommunication network system for coal mine worker safety. Monitoring ofthe workers safety in the coal miners is challenging one. Because it is hard topredict the evolution of dangerous gas inside the coal mines. Lack of efficientsystem in the coal miners is affecting the lives of the workers in terms ofdeath. Coal miners are located near to the forest and outskirts of the urban/rural areas. And here communication network plays a crucial role formonitoring the coal mines. The present system is integration of RF basedbeacons, local control unit, vision gateway and data collector and visionnode.~NE™ numbers of beacons are deployed in the coal miners at differentposition for sensing the dangerous gas that evolve inside the mines.

No. of Pages : 15 No. of Claims : 10

(12) PATENT APPLICATION PUBLICATION

(21) Application
No.201911050425 A

(19) INDIA

(22) Date of filing of Application :06/12/2019

(43) Publication Date :
20/12/2019

(54) Title of the invention : A SYSTEM OF FEATURE EXTRACTION FOR LEUCAENA (BAMBOO) TREE AND USES THEREOF

(51)
International :G06K0009620000,G06Q0010060000,G08G0001140000,G06F0016901000,G16H0050200000
classification
(31) Priority
Document :NA
No
(32) Priority :NA
Date
(33) Name
of priority :NA
country
(86)
International
Application :NA
No :NA
Filing
Date
(87)
International : NA
Publication
No
(61) Patent
of Addition
to
Application :NA
Number :NA
Filing
Date
(62)
Divisional to
Application :NA
Number :NA
Filing
Date

(71)Name of Applicant
:
**1)Lovely
Professional University**
Address of
Applicant :Lovely
Professional University,
Delhi Jalandhar GT road
Phagwara- 144411.
Punjab India
(72)Name of Inventor :
**1)Anita Gehlot
2)Rajesh Singh
3)Navjot Rathour**

(57) Abstract :

The present invention relates to a system of feature extraction for Leucaena (bamboo) tree and uses thereof. The main aim of this patent is to determine the quality of Leucaena tree (Subabul in southern part of India mainly and bamboo in northern part of India) based on diameter and strongness of the tree determines its quality, life span, strongness and agility of the crop. Disclosed herein a System of feature extraction for Leucaena (Bamboo) tree comprises Sensory node (101), field aggregator (104), cloud server (105); wherein the communication establishes between N fields with N number of Aggregators; and all said Aggregators are capable to communicate with Central Cloud Server.

No. of Pages : 13 No. of Claims : 7

(12) PATENT APPLICATION PUBLICATION

(21) Application
No.201911050426 A

(19) INDIA

(22) Date of filing of Application :06/12/2019

(43) Publication Date :
20/12/2019

(54) Title of the invention : A SYSTEM OF FLOOD WARNING WITH LONG RANGE (LORA) COMMUNICATION NETWORK & IOT

(51)
International :H04L0029060000,H04W0004800000,G08B0021100000,H02J0013000000,G08G0001096700
classification

(31) Priority
Document :NA
No

(32) Priority :NA
Date

(33) Name
of priority :NA
country

(86)
International
Application :NA
No :NA

Filing
Date

(87)
International : NA
Publication
No

(61) Patent
of Addition
to
Application :NA
Number :NA
Filing

Date

(62)
Divisional to
Application :NA
Number :NA
Filing

Date

(71)**Name of Applicant**
:
**1)Lovely Professional
University**

Address of
Applicant :Lovely
Professional University,
Delhi Jalandhar GT road
Phagwara- 144411.
Punjab India

(72)**Name of Inventor :**
1)SINGH, Rajesh
2)Gehlot, Anita
3)Akram, Shaik
Vaseem
**4)Sharma , Kamal
Kumar**

(57) Abstract :

The present invention relates to a system of Flood warning with long range (LoRa) communication network & IoT. Herein a system is proposed for enhancing the flood warning system especially in localized areas using LoRa (Long Range) and RF communication. The proposed system comprises of smart water level communication with Short range RF communication. 'N' number of smart water level communication devices will be positioned at the corner of river bank for acquiring the real time water level data. The smart water level communication unit communicates the water level of the river to the local information collector via RF communication. A vision device is embedded near to the smart communication device for capturing the live visuals of flood situation in that location.

No. of Pages : 18 No. of Claims : 9

(12) PATENT APPLICATION PUBLICATION

(21) Application
No.201911050427 A

(19) INDIA

(22) Date of filing of Application :06/12/2019

(43) Publication Date :
20/12/2019

(54) Title of the invention : A SYSTEM FOR BAR CODE AUTOMATIC LOGIN AND ATTENDANCE MARKING

(51)
International :G07C0009000000,H05B0033080000,G01N0001400000,A61B0090900000,B60R0025250000
classification
(31) Priority
Document :NA
No
(32) Priority :NA
Date
(33) Name
of priority :NA
country
(86)
International
Application :NA
No :NA
Filing
Date
(87)
International : NA
Publication
No
(61) Patent
of Addition
to
Application :NA
Number :NA
Filing
Date
(62)
Divisional to
Application :NA
Number :NA
Filing
Date

(71)**Name of Applicant**
:
**1)Lovely Professional
University**
Address of
Applicant :Lovely
Professional University,
Delhi Jalandhar GT road
Phagwara- 144411.
Punjab India
(72)**Name of Inventor :**
**1)Dushyant Kumar
Singh**
2)Kanwaljeet Singh
**3)Sarvesh Dhar
Dwivedi**
**4)Kumari Neha
Singh**

(57) Abstract :

The present invention is an automated system that is use to marking attendance using bar-code on ID card. The input obtained by bar-code send to centralize server and attendance will be marked. The system will be controlled using a microcontroller-based board and relay module. The input obtained by the microcontroller will be from the bar-code scanner and camera module. Also, the proposed system provides the automatic control on electrical devices in class rooms or in offices. Also, the proposed system provides Authorized person login for authentication and provide bio-metric scan to prevent from frogging and getting wrong access.

No. of Pages : 12 No. of Claims : 6

(12) PATENT APPLICATION PUBLICATION

(21) Application
No.201911050428 A

(19) INDIA

(22) Date of filing of Application :06/12/2019

(43) Publication Date :
20/12/2019

(54) Title of the invention : A DEVICE FOR LOCATION DETECTION FOR SOLDIERS STRUCK IN CRITICAL AREAS

(51)
International :G01S0005020000,H04W0004020000,H04W0056000000,H01L0027020000,H04W0048040000
classification
(31) Priority
Document :NA
No
(32) Priority :NA
Date
(33) Name
of priority :NA
country
(86)
International
Application :NA
No :NA
Filing
Date
(87)
International : NA
Publication
No
(61) Patent
of Addition
to
Application :NA
Number :NA
Filing
Date
(62)
Divisional to
Application :NA
Number :NA
Filing
Date

(71)**Name of Applicant :**
1)Lovely Professional University
Address of Applicant :Lovely Professional University, Delhi Jalandhar GT road Phagwara- 144411. Punjab India
(72)**Name of Inventor :**
1)SINGH, Rajesh
2)Gehlot, Anita
3)Akram, Shaik Vaseem
4)Gupta, Lovi Raj

(57) Abstract :

The present invention is a device for location detection for soldiers struck in critical areas. Generally, in the wars or during performing the secret operation by soldiers, in some cases the connectivity will be lost from the injured soldier or the soldier may get struck down in the place where the connectivity is unavailable. To overcome this challenge, a novel system is proposed for detecting the location of soldier through long range communication. Disclosed herein a device for location detection for soldiers struck in critical areas comprises Location mapping node (98...90, 80 70) having microcontroller units (108,112), and a RF modem to communicate the location of the soldier to a local repeater unit. FIGURE 1 NOVEL ARCHITECTURE FOR LOCATION DETECTION OF SOLDIERS

No. of Pages : 13 No. of Claims : 7

(12) PATENT APPLICATION PUBLICATION

(21) Application
No.201911050429 A

(19) INDIA

(22) Date of filing of Application :06/12/2019

(43) Publication Date :
20/12/2019

(54) Title of the invention : A MULTI-PURPOSE SMART OFFICE/STUDY TABLE WITH RECORDING ASSISTANCE

(51)
International :A61J0009060000,G06K0009200000,F01L0001340000,B23K0026030000,A63B0057000000
classification
(31) Priority
Document :NA
No
(32) Priority :NA
Date
(33) Name
of priority :NA
country
(86)
International
Application :NA
No :NA
Filing
Date
(87)
International : NA
Publication
No
(61) Patent
of Addition
to
Application :NA
Number :NA
Filing
Date
(62)
Divisional to
Application :NA
Number :NA
Filing
Date

(71)**Name of Applicant :**
1)Lovely Professional University
Address of Applicant
:Lovely Professional University, Jalandhar-Delhi G.T. Road, Phagwara, Punjab-144 411, India Punjab India
(72)**Name of Inventor :**
1)Dr. Piyush Gulati
2)Dasari Narasimha
3)Mohammad Feroz Ahmad Qureshi
4)Mulagala Siva Shankar
5)Boga Srikanth
6)Dr. Manpreet Singh
7)Jai Inder Preet Singh
8)Dr. Satnam Singh
9)Rajeev Kumar

(57) Abstract :

The present invention having a multi-functional plank consisting of alamp, an adjustable mechanism to set the angle, a bottle holder, foldablelegs, extendable pad, and a camera to record the sitting time has beendesigned. The plank is adjustable at any angle with the help of adjustablemechanism. The real time problems of using plank in darkness and stationarybuild of plank has been taken into consideration.

No. of Pages : 10 No. of Claims : 6

(12) PATENT APPLICATION PUBLICATION

(21) Application
No.201911050430 A

(19) INDIA

(22) Date of filing of Application :06/12/2019

(43) Publication Date :
20/12/2019

(54) Title of the invention : A SYSTEM FOR EMOTION RECOGNITION BASED AUDIENCE INVOLVEMENT ANALYSIS

(51)
International :G11B0027110000,H04N0021442000,G10L0025510000,G10L0017260000,H04N0007100000
classification
(31) Priority
Document :NA
No
(32) Priority
Date :NA
(33) Name
of priority :NA
country
(86)
International
Application :NA
No :NA
Filing
Date
(87)
International
Publication : NA
No
(61) Patent
of Addition
to
Application :NA
Number :NA
Filing
Date
(62)
Divisional to
Application :NA
Number :NA
Filing
Date

(71)**Name of Applicant**
:
**1)Lovely Professional
University**
Address of
Applicant :Lovely
Professional University,
Delhi Jalandhar GT road
Phagwara- 144411.
Punjab India
(72)**Name of Inventor :**
1)Dr. Rajesh Singh
2)Dr. Anita Gehlot
3)Navjot Rathour
4)Prabin Kumar Das
**5)Km Vaishnavi
Gupta**
6)Bishwajyoti Roy
**7)MD Mazharul
Islam Miraz**

(57) Abstract :

The present invention is a system for Emotion recognition based audience involvement analysis comprising; a speaker end node, an audience end node and a central node. wherein the speaker end node further comprising; a speaker, an inbuilt mic with a computing unit along with the time stamp and a local storage device. The Speaker's End Node records the real-time speech of the speaker using an inbuilt mic with a computing unit along with the timestamp and then converts the speech into text and sends these data to the central node using RF communication and saves it into the connected local storage device. The audience end node further comprising, a camera, a computing unit and a local storage device. Audience's End Node deploy near the audience which uses a camera connected to a computing unit to perform emotion and sentimental analysis of each individual audience considering their age and gender as the factors and plot them into a time vs sentiment graph in real time, then sends these data to the central node using RF communication and saves it into the connected local storage device. Central Node receives the data from end node's in real time using RF communication and sends these data to the dedicated IoT server using GSM or Wi-Fi and saves the data into the connected local storage device.

No. of Pages : 13 No. of Claims : 7

(12) PATENT APPLICATION PUBLICATION

(21) Application
No.201911050447 A

(19) INDIA

(22) Date of filing of Application :06/12/2019

(43) Publication Date :
20/12/2019

(54) Title of the invention : A SYSTEM FOR INSTA CAPACITOR-BASED CAR JUMP STARTER

(51)
International :H02J0007000000,H02J0007340000,F02N0011080000,H02J0001000000,B60R0016030000
classification
(31) Priority
Document :NA
No
(32) Priority :NA
Date
(33) Name
of priority :NA
country
(86)
International
Application :NA
No :NA
Filing
Date
(87)
International
Publication : NA
No
(61) Patent
of Addition
to
Application :NA
Number :NA
Filing
Date
(62)
Divisional to
Application :NA
Number :NA
Filing
Date

(71)**Name of Applicant :**
**1)Lovely Professional
University**
Address of Applicant
:Lovely Professional
University, Jalandhar-
Delhi G.T. Road,
Phagwara 144411, Punjab,
India Punjab India
(72)**Name of Inventor :**
1)Mandeep Singh
2)Sorabh Lakhnupal
3)Ruhul Amin
Choudhury

(57) Abstract :

Disclosed is a system for instacapacitor-basedcar jump starterforstarting car. The present invention uses plurality ofcapacitor; a connection and distribution board; a control board; a voltage regulator; a cut-off system for one-waycharging; a body; a jump starter terminal; a connectorfor making it portable; a connectionwires; and a car battery.This system uses the capacitors-basedjump starter andis connected to the car power source and when car engine is stopped, the battery not get discharged and cut it automatically from the car power source. The present inventionworks even if jump starter gets drained outas it isinstantly charged from another car power source to reuse again.

No. of Pages : 10 No. of Claims : 6

(12) PATENT APPLICATION PUBLICATION

(21) Application
No.201911050534 A

(19) INDIA

(22) Date of filing of Application :06/12/2019

(43) Publication Date :
20/12/2019

(54) Title of the invention : Road-transport for Daily Essential Services (RoDES)

(51)
International :C08L0067040000,B60R0025040000,B09B0001000000,A01N0065000000,G01J0001020000
classification
(31) Priority
Document :NA
No
(32) Priority :NA
Date
(33) Name
of priority :NA
country
(86)
International
Application :PCT//
No :01/01/1900
Filing
Date
(87)
International
Publication : NA
No
(61) Patent
of Addition
to
Application :NA
Number :NA
Filing
Date
(62)
Divisional to
Application :NA
Number :NA
Filing
Date

(71)Name of Applicant :
1)Dr. Sandeep Saxena
Address of Applicant
:Department of IT,
Galgotias College of
Engineering and
Technology, Plot No.1,
Knowledge Park-II,
Greater Noida (U.P),
INDIA PIN ; 201306
Uttar Pradesh India
2)Mr. Raghav Garg
3)Mr. Pundreek
Saurabh Srivastava
4)Mr. Rahul Dwivedi
5)Dr. Subhash Kumar
Verma
6)Dr. Sunil Kumar
Bharti
(72)Name of Inventor :
1)Dr. Sandeep Saxena
2)Mr. Raghav Garg
3)Mr. Pundreek
Saurabh Srivastava
4)Mr. Rahul Dwivedi
5)Dr. Subhash Kumar
Verma
6)Dr. Sunil Kumar
Bharti

(57) Abstract :

No. of Pages : 0 No. of Claims : 0

(12) PATENT APPLICATION PUBLICATION

(21) Application
No.201911050565 A

(19) INDIA

(22) Date of filing of Application :07/12/2019

(43) Publication Date :
20/12/2019

(54) Title of the invention : ORTHOGRAPHIC IMAGE GENERATOR

(51)
International :H04N0005232000,G06M0009000000,G06M0001100000,G01C0011020000,G06T0007380000
classification
(31) Priority
Document :NA
No
(32) Priority :NA
Date
(33) Name
of priority :NA
country
(86)
International
Application :NA
No :NA
Filing
Date
(87)
International
Publication : NA
No
(61) Patent
of Addition
to
Application :NA
Number :NA
Filing
Date
(62)
Divisional to
Application :NA
Number :NA
Filing
Date

(71)Name of
Applicant :
**1)INDIAN
INSTITUTE OF
TECHNOLOGY
KANPUR**
Address of
Applicant :Dean,
Research &
Development, Room
Number 151, Faculty
Building, Post Office:
IIT Kanpur, Kanpur
208016, Uttar Pradesh,
India Uttar Pradesh
India
(72)Name of Inventor
:
**1)SINGH,
Siddharth J.
2)SUBRAMANIAN,
Venkatesh K
3)MOHAN, Vidya**

(57) Abstract :

A system and an orthographic image capturing method thereof for counting stacked objects, characterized in that, the method comprising: taking a series of images, by an orthographic image capturing system, said system being operably placed perpendicular to at least one axis of symmetry of the stacked objects, said orthographic image capturing system being operably controlled to move in a rectangular grid fashion to cover the entire dimensions of the stacked objects; stitching, the series of images taken by an orthographic image capturing system, to provide an orthographic image of the scene for counting stacked objects or dimensional measurement, wherein the stitching of the series of images further comprises: sampling of a subset of an image taken, ray bundles, to reconstruct an orthographic image and providing information overlap between the ray bundles to construct a registered image, and processing the stitched images to count the objects or measure dimensions. Figures 1 and 7

No. of Pages : 28 No. of Claims : 7

(12) PATENT APPLICATION PUBLICATION

(21) Application
No.201911050566 A

(19) INDIA

(22) Date of filing of Application :07/12/2019

(43) Publication Date :
20/12/2019

(54) Title of the invention : AN EMBEDDED TRAIN COMMUNICATION SYSTEM FOR TRAIN COLLISION AVOIDANCE

(51)
International :B61L0015000000,H04N0007180000,B61L0027000000,G08B0021060000,H04L0009320000
classification
(31) Priority
Document :NA
No
(32) Priority
Date :NA
(33) Name
of priority :NA
country
(86)
International
Application :NA
No :NA
Filing
Date
(87)
International
Publication : NA
No
(61) Patent
of Addition
to
Application :NA
Number :NA
Filing
Date
(62)
Divisional to
Application :NA
Number :NA
Filing
Date

(71)**Name of Applicant**
:
**1)Lovely Professional
University**
Address of Applicant
:Lovely Professional
University, Delhi
Jalandhar GT road
Phagwara- 144411.
Punjab India
(72)**Name of Inventor :**
1)Rajesh Singh
2)Anita Gehlot
**3)Akram, Shaik
Vaseem**
4)Sharma, Neeta Raj

(57) Abstract :

The present invention comprising, a train communication unit, having; a LoRa modem(104), a controller (101), raspberry pi(103), camera and LED display(107), battery(100), storage (106), wherein, LoRa communication modem use for communication between two trains within the range of 10 kms. The claimed communication system having a train communication unit of one train can transfer its information like train number, track detail to other train info communication unit which is within the coverage 10 kms. The LED display use for the information of other train to be displayed. The communication having a camera with raspberry pi is used for drowsiness detection of train driver. The individual train info communication unit having facility to connect with internet where it get connected signal for internet otherwise it store communication information inside storage.

No. of Pages : 11 No. of Claims : 6

(12) PATENT APPLICATION PUBLICATION

(21) Application
No.201911050567 A

(19) INDIA

(22) Date of filing of Application :07/12/2019

(43) Publication Date :
20/12/2019

(54) Title of the invention : A WIRELESS CONTROLLED HOOTER SYSTEM FOR FIRE ALARM

(51)
International :H04L0029080000,G08B0017113000,G08B0017000000,G08B0017100000,H04W0004020000
classification

(31) Priority
Document :NA
No

(32) Priority
Date :NA

(33) Name
of priority :NA
country

(86)
International
Application :NA
No :NA

Filing
Date

(87)
International
Publication : NA
No

(61) Patent
of Addition
to
Application :NA
Number :NA

Filing
Date

(62)
Divisional to
Application :NA
Number :NA

Filing
Date

(71)Name of Applicant
:

**1)Lovely
Professional
University**
Address of
Applicant :Lovely
Professional University,
Delhi Jalandhar GT
road Phagwara- 144411.
Punjab India

(72)Name of Inventor :

**1)Dr. Rajesh Singh
2)Dr. Anita Gehlot
3)Shaik Vaseem
Akram
4)Dr. Neeta Raj**

(57) Abstract :

The present invention is to strength the hooter control system with internet of things. An innovative intelligent hooter control system is proposed for mock drill and fire alarm system with internet of things. Intelligent hooter system is integrated with the smoke detector and fire detector for alerting the fire incident in any location through RF communication. The information related to the fire incident is uploaded to thecloud server for further surveillance. With the assistance of mobile app, the hooters can be triggered when fire incident is detected.

No. of Pages : 11 No. of Claims : 6

(12) PATENT APPLICATION PUBLICATION

(21) Application
No.201911050568 A

(19) INDIA

(22) Date of filing of Application :07/12/2019

(43) Publication Date :
20/12/2019

(54) Title of the invention : A ROBOTIC SYSTEM FOR TOUR IN THE PRE-DEFINED PREMISES

(51)
International :H04L0029080000,B25J0009160000,A61B0034300000,G09B0005060000,G01C0021340000
classification
(31) Priority
Document :NA
No
(32) Priority :NA
Date
(33) Name
of priority :NA
country
(86)
International
Application :NA
No :NA
Filing
Date
(87)
International
Publication : NA
No
(61) Patent
of Addition
to
Application :NA
Number :NA
Filing
Date
(62)
Divisional to
Application :NA
Number :NA
Filing
Date

(71)**Name of Applicant :**
**1)Lovely Professional
University**
Address of Applicant
:Lovely Professional
University, Jalandhar-
Delhi G.T. Road,
Phagwara 144411,
Punjab, India Punjab
India
(72)**Name of Inventor :**
1)Dr. Rajesh Singh
2)Dr. Anita Gehlot
3)Vinay
4)Dr. Lovi Raj Gupta
5)Manikant Roy

(57) Abstract :

The present invention is related to the IoT based Robotic system for tour in the pre-defined premises. The architecture of the guide robot is shown in figure.1. The architecture comprises of Xbee RF node, master unit, slave unit and RF modem. A tour guide robot is designed for specific premises. It follows a predefined route. Robot follows a path where it comes in the range of nodes placed at different locations. These nodes are connected with XBee protocol. When robot comes into the range of node, it start displaying the information about that area and plays audio for it.

No. of Pages : 13 No. of Claims : 7

(12) PATENT APPLICATION PUBLICATION

(21) Application
No.201911050569 A

(19) INDIA

(22) Date of filing of Application :07/12/2019

(43) Publication Date :
20/12/2019

(54) Title of the invention : A DEVICE FOR PLANT IDENTIFICATION

(51)
International :G06T0001200000,G03B0017020000,G05B0023020000,G06N0003080000,G05B0013020000
classification

(31) Priority
Document :NA
No

(32) Priority
Date :NA

(33) Name
of priority :NA
country

(86)
International
Application :NA
No :NA

Filing
Date

(87)
International
Publication : NA
No

(61) Patent
of Addition
to
Application :NA
Number :NA

Filing
Date

(62)
Divisional to
Application :NA
Number :NA

Filing
Date

(71)**Name of Applicant**
:
**1)Lovely Professional
University**

Address of
Applicant :Lovely
Professional University,
Delhi Jalandhar GT road
Phagwara- 144411.
Punjab India

(72)**Name of Inventor :**
1)Dev Jain

2)Akash Upadhyay
3)Dr. Rajesh Singh
4)Dr. Anita Gehlot
**5)Dr. Kamal Kumar
Sharma**

(57) Abstract :

Disclosed herein, a Device for Plant Identification, comprising, a Camera unit (100) & an ECU unit; wherein ECU (Electronics Control Unit) unit further comprising, keyboard and mouse (104), raspberry PI module (101) and GPU (Graphics Processing Unit) (102), Power supply Unit (103) and artificial neural network (ANN). Camera unit & ECU (Electronics Control Unit) are placed on the front end of the stick, so the user has to point the camera in front of the plant and let system feed and process image. If the system already know the plant species it will show the plant label, otherwise it will ask to provide the labels for learning from the data thus it can be used for future use.

No. of Pages : 13 No. of Claims : 7

(12) PATENT APPLICATION PUBLICATION

(21) Application
No.201911050570 A

(19) INDIA

(22) Date of filing of Application :07/12/2019

(43) Publication Date :
20/12/2019

(54) Title of the invention : A SYSTEM TO READ TEXT FROM POSTERS AND SIGN-BOARDS FOR BLIND

(51)
International :H04N0007180000,G06K0009000000,H04N0005225000,G06Q0050100000,H04N0005760000
classification
(31) Priority
Document :NA
No
(32) Priority :NA
Date
(33) Name
of priority :NA
country
(86)
International
Application :NA
No :NA
Filing
Date
(87)
International : NA
Publication
No
(61) Patent
of Addition
to
Application :NA
Number :NA
Filing
Date
(62)
Divisional to
Application :NA
Number :NA
Filing
Date

(71)**Name of Applicant**
:
**1)Lovely
Professional
University**
Address of
Applicant :Lovely
Professional University,
Delhi Jalandhar GT
road Phagwara-
144411. Punjab India
(72)**Name of Inventor**
:
**1)Dharmani ,
Bhavesh Kumar
Choithram**
2)Ghai, Deepika
3)SINGH, Rajesh
4)Gehlot, Anita
5)Rathour, Navjot

(57) Abstract :

The present invention relates to IoT based sign board reader system or blind and Poster. The present invention having Camera and image/video acquisition system and mobile app. The camera and image/ video acquisition system is a head mount device with Bluetooth enabled camera, ability of rotation by 180 degree and facility to transfer the acquired images and video to mobile phone with the blind individual. The mobile app will be able to receive and then process the image and video captured by the acquisition system.

No. of Pages : 11 No. of Claims : 4

(12) PATENT APPLICATION PUBLICATION

(21) Application
No.201911050571 A

(19) INDIA

(22) Date of filing of Application :07/12/2019

(43) Publication Date :
20/12/2019

(54) Title of the invention : A LORA & CLOUD SERVER BASED SYSTEM FOR HEALTH MONITORING OF THE RAILWAY CROSSING LINE

(51)
International :B61L0029300000,B29C0045760000,H04W0004700000,G07C0009020000,B61L0023040000
classification
(31) Priority
Document :NA
No
(32) Priority :NA
Date
(33) Name
of priority :NA
country
(86)
International
Application :NA
No :NA
Filing
Date
(87)
International : NA
Publication
No
(61) Patent
of Addition
to
Application :NA
Number :NA
Filing
Date
(62)
Divisional to
Application :NA
Number :NA
Filing
Date

(71)**Name of Applicant**
:
1)Lovely Professional University
Address of
Applicant :Lovely
Professional University,
Delhi Jalandhar GT road
Phagwara- 144411.
Punjab India
(72)**Name of Inventor :**
1)Dr. Rajesh Singh
2)Dr. Anita Gehlot
3)Shaik Vaseem Akram
4)Dr. Dharam Buddhi

(57) Abstract :

The present invention is a system, proposed for controlling and monitoring the railway cross line gates with LoRa (Long Range) communication and cloud server. Traditional system lacks a reliable communication between the cross level gate and control system. A system is proposed for real time monitoring of railway crossing level using internet of things. The proposed system is integration of two different units, namely train arrival information device and gate controller device. The train arrival information device is positioned 4 km far away from the gate controller device for signaling the arrival of train. The train arrival information device which senses the arrival of time through vibration sensor and also the arrival of train is logged into cloud server via internet. Gate controller device is embedded to cross line gate for automatic controlling of gate according to the data received from the information device via LoRa modem.

No. of Pages : 11 No. of Claims : 7

(12) PATENT APPLICATION PUBLICATION

(21) Application
No.201911050572 A

(19) INDIA

(22) Date of filing of Application :07/12/2019

(43) Publication Date :
20/12/2019

(54) Title of the invention : A DEVICE TO CONTROL VEHICLE HEAD LIGHT AND METHOD THEREOF

(51)
International :B60Q0001140000,B60R0025102000,B60R0016030000,B60R0021010000,H04M0001600000
classification
(31) Priority
Document :NA
No
(32) Priority :NA
Date
(33) Name
of priority :NA
country
(86)
International
Application :NA
No :NA
Filing
Date
(87)
International : NA
Publication
No
(61) Patent
of Addition
to :NA
Application :NA
Number :NA
Filing
Date
(62)
Divisional to
Application :NA
Number :NA
Filing
Date

(71)Name of Applicant
:
**1)Lovely Professional
University**
Address of
Applicant :Lovely
Professional University,
Delhi Jalandhar GT road
Phagwara- 144411.
Punjab India
(72)Name of Inventor :
**1)Anita Gehlot
2)Rajesh Singh
3)Mahesh Kumar
Prajapat
4)Navjot Rathour
5)Dr. Lovi Raj Gupta**

(57) Abstract :

The present invention relates to a device to control vehicle head light and method thereof. In present invention, device can be easily installed inside the vehicle lights which can detect the Vehicle lights either ON/OFF and can send a notification either on a Mobile app or by text and email regarding the status of lights on vehicle. From that SMS and email or information from an app vehicle owner can trigger a signal to the device which can automatically turn off the car lights. Disclosed herein a device to control vehicle head light comprises LDR (101); a Nutty Fi/Node MCU (102), a Power Supply (103), Relay Module (104), a Car Battery (105), Car Headlight (106), Vibration Sensor Array (107), and Mobile Application (108).

No. of Pages : 9 No. of Claims : 6

(12) PATENT APPLICATION PUBLICATION

(21) Application
No.201911050580 A

(19) INDIA

(22) Date of filing of Application :07/12/2019

(43) Publication Date :
20/12/2019

(54) Title of the invention : A SYSTEM OF VISION BASED COUNTING OF CEMENT BAGS IN LOADED TRUCK

(51)
International :G06K0009000000,G06K0009660000,G06T0007136000,A61J0007020000,G06T0007200000
classification
(31) Priority
Document :NA
No
(32) Priority :NA
Date
(33) Name
of priority :NA
country
(86)
International
Application :NA
No :NA
Filing
Date
(87)
International
Publication : NA
No
(61) Patent
of Addition
to
Application :NA
Number :NA
Filing
Date
(62)
Divisional to
Application :NA
Number :NA
Filing
Date

(71)**Name of Applicant :**
**1)Lovely Professional
University**
Address of Applicant
:Lovely Professional
University, Delhi
Jalandhar GT road
Phagwara- 144411.
Punjab India
(72)**Name of Inventor :**
1)SINGH, Rajesh
2)Rathour, Navjot
3)Gehlot, Anita

(57) Abstract :

The present invention relates to a system of vision based counting of cement bags in loaded truck. The present invention also resolves the manual calculation problem of cement bags inside a loaded truck. The present system provided TPU and system is already pretrained to detect the objects in real time so it will automatically detect the Cement bags inside the truck while loading and unloading the counter will automatically count and updated after detecting the cement bags via pi-camera in real time. Figure 3 shows the flow chart of the system that explains the basic steps to followed by this device for detecting the object in Real-time.

No. of Pages : 11 No. of Claims : 4

(12) PATENT APPLICATION PUBLICATION

(21) Application
No.201911050581 A

(19) INDIA

(22) Date of filing of Application :07/12/2019

(43) Publication Date :
20/12/2019

(54) Title of the invention : AN AUDIO GUIDANCE SYSTEM FOR DOCTOR PRESCRIPTION

(51)
International :G10L0013000000,G10L0017000000,G07F0017000000,H04M0003510000,G10L0013027000
classification

(31) Priority
Document :NA
No

(32) Priority
Date :NA

(33) Name
of priority :NA
country

(86)
International
Application :NA
No :NA

Filing
Date

(87)
International
Publication : NA
No

(61) Patent
of Addition
to
Application :NA
Number :NA

Filing
Date

(62)
Divisional to
Application :NA
Number :NA

Filing
Date

(71)Name of Applicant
:
**1)Lovely Professional
University**

Address of Applicant
:Lovely Professional
University, Jalandhar-
Delhi G.T. Road,
Phagwara 144411,
Punjab, India Punjab
India

(72)Name of Inventor :
**1)Rajesh Singh
2)Anita Gehlot
3)Lovi Raj Gupta**

(57) Abstract :

The present invention provides an Audio guidance system for Doctor Prescription, comprising, audio guide unit connected to cloud server. The audio guidance system consists an audio guide unit further comprises, Raspberry Pi, controller, convertor, battery, camera and speaker. The audio guidance system is having a camera, which captures and processes the image of the prescription. The audio guidance system comprises a convertor, which converts text of the prescription to speech. Speaker of the audio guidance system is used as an output device.

No. of Pages : 7 No. of Claims : 6

(12) PATENT APPLICATION PUBLICATION

(21) Application
No.201911050633 A

(19) INDIA

(22) Date of filing of Application :07/12/2019

(43) Publication Date :
20/12/2019

(54) Title of the invention : TRANSPARENT PACKAGING LAMINATE WITH IMPROVED WATER VAPOUR BARRIER PROPERTIES

(51)
International :B32B0027320000,C08J0005180000,B32B0038000000,C08K0005098000,D21H0027100000
classification

(31) Priority
Document :NA
No

(32) Priority :NA
Date

(33) Name
of priority :NA
country

(86)
International
Application :NA
No :NA

Filing
Date

(87)
International : NA
Publication
No

(61) Patent
of Addition
to
Application :NA
Number :NA

Filing
Date

(62)
Divisional to
Application :NA
Number :NA

Filing
Date

(71)**Name of Applicant :**
**1)GLS FILMS
INDUSTRIES PVT.
LTD.**

Address of Applicant
:Opp. Brahma Kumari
Ashram, Pataudi Road,
Bhora Kalan, Bilaspur,
Dist. Gurugram,
Haryana-122413, India
Haryana India

(72)**Name of Inventor :**
**1)MUTHUSAMY
CHOCKALINGAM
2)SHIBAN LAL
KAUL
3)SANDEEP GOYAL**

(57) Abstract :

The present invention provides a water vapour barrier coated laminate with improved barrier properties, wherein the laminate is made of biaxially oriented polypropylene (BOPP) substrate and another transparent lamination film. The laminate shows excellent water vapour barrier properties, and excellent light transmittance. Specifically, the water vapour barrier coated laminate includes a BOPP substrate, on which water vapour barrier coating is applied, and a printing ink layer is applied on the top of the water vapour barrier coating layer; in turn a layer of adhesive is applied on the printing ink layer, and then the transparent film such as a cast polypropylene (CPP) film, a polyethylene (PE) film, or a second BOPP film is laminated to the adhesive applied side of the BOPP substrate.

No. of Pages : 17 No. of Claims : 10

(12) PATENT APPLICATION PUBLICATION

(21) Application
No.201911050635 A

(19) INDIA

(22) Date of filing of Application :08/12/2019

(43) Publication Date :
20/12/2019

(54) Title of the invention : A CATALYST FOR PYROLYSIS OF MIXED PLASTIC WASTE AND A METHOD OF PYROLYSIS THEREOF

(51)
International :C10G0001100000,C10B0053070000,B01J0029870000,B01J0037030000,C10G0001080000
classification

(31) Priority
Document :NA
No

(32) Priority :NA
Date

(33) Name
of priority :NA
country

(86)
International
Application :NA
No :NA

Filing
Date
(87)

International : NA
Publication
No

(61) Patent
of Addition
to
Application :NA
Number :NA

Filing
Date
(62)

Divisional to
Application :NA
Number :NA

Filing
Date

(71)**Name of Applicant :**
**1)University of
Petroleum and Energy
Studies**

Address of Applicant
:Energy Acres, Bidholi,
Premnagar, Dehradun,
Uttarakhand, India-
248007 Uttarakhand India

(72)**Name of Inventor :**
**1)Praveen Kumar
Ghodke**

2)Krishna Moorthy

3)Surajit Mondal

**4)Jitendra Kumar
Pandey**

**5)Venkateswarlu
Chintala**

(57) Abstract :

Present invention provides a catalyst capable for in-situ pyrolysis in a pyrolysis reactor. More particularly, the invention relates to the catalyst for in-situ pyrolysis of plastic waste for producing gasoline range fuel, efficiently. The invention also relates to a process for pyrolysis of plastic waste for producing gasoline range fuel. A catalyst for in-situ pyrolysis, said catalyst comprises of inorganic hydroxyl group OH, 50 % w/w of oxides of aluminum and 30 % w/w of oxide of silica; characterized in that pKa range of strongest sites of catalyst is < - 8.1 and total acidity to pKa 4.0 is 0.05 meq amines/g catalyst.

No. of Pages : 46 No. of Claims : 7

(54) Title of the invention : ITDM-SYSTEM: INTELLIGENT TRAFFIC CONTROL AND TRAFFIC DUTY MANAGEMENT SYSTEM.

(51)
International :G08G0001080000,G08G0001095000,G08G0001010000,G08G0001081000,G08G0001082000
classification
(31) Priority
Document :NA
No
(32) Priority :NA
Date
(33) Name
of priority :NA
country
(86)
International
Application :NA
No :NA
Filing
Date
(87)
International
Publication : NA
No
(61) Patent
of Addition
to :NA
Application :NA
Number :NA
Filing
Date
(62)
Divisional to
Application :NA
Number :NA
Filing
Date

(71)Name of Applicant :
1)DR. KAMALI GUPTA
Address of Applicant :ASSOCIATE
PROFESSOR,DEPARTMENT OF COMPUTER
SCIENCE & ENGINEERING CHITKARA
UNIVERSITY INSTITUTE OF ENGINEERING &
TECHNOLOGY,CHITKARA UNIVERSITY,
RAJPURA, INDIA kamali.singla@chitkara.edu.in,
ADHAAR NO:- 365677673329 Punjab India
2)DR. DEEPALI GUPTA
3)DR. VIDHU BAGGAN
4)PROF. ABHAY SAXENA
5)DR. NAVEEN KUMAR PANDEY
6)DR. SANJAY KUMAR TIWARI
7)DR. VARINDER SINGH
8)DR. VIPIN JAIN
9)DR.ARPIT JAIN
(72)Name of Inventor :
1)DR. KAMALI GUPTA
2)DR. DEEPALI GUPTA
3)DR. VIDHU BAGGAN
4)PROF. ABHAY SAXENA
5)DR. NAVEEN KUMAR PANDEY
6)DR. SANJAY KUMAR TIWARI
7)DR. VARINDER SINGH
8)DR. VIPIN JAIN
9)DR.ARPIT JAIN

(57) Abstract :

My Invention ITDM-System is a intelligent traffic control system includes a micro controller ,an data processing unit ,a data bus to taking status from a traffic light system and some obstacle bars - side bars. This invention ITDM-System also take carefully like data processing unit, controls unit, behavior and other display based on the information of data bars. The controller device controls the activation of red, orange and green lights the whole traffic control system or traffic signal system. In our invention ITDM-System there are some obstacle bars and side bars mounted on it. At the end of orange light activate then obstacle bars comes up vertically. They remain in standing position until the red light turns in green. The main motto of the system is to avoid accidents and to maintain disciplinary actions. This invention ITDM-System take auto decision if any special vehicle needed to move then also allow according to current situation. My Invention ITDM-System also an intelligent traffic management system based on an inter-vehicle network comprises a wireless communication module, a computation module, a control module, a traffic light signal display module, a storage module and a fault detection module, is in communication with an inter-vehicle network communication management device on a vehicle through the wireless communication module, and computes traffic flow and density at road junctions by combining internal algorithm of the computation module. By the aid of the ITDM-System in the technical scheme, technical problems that road traffic ability is low, consequentially energy sources and time are wasted and the like due to the fact that traffic signal control systems in the prior art cannot acquire traffic flow and vehicle running speed accurately are solved. The ITDM-System based on the inter-vehicle network has the advantages that accurate traffic information of vehicles at the road junctions can be acquired in time, time setting of traffic lights can be adjusted in time, traffic efficiency of roads is improved, running speed of special vehicles such as firefighting vehicles, ambulances and the like is guaranteed, an automatic fault detection function can be realized, the time setting of the traffic lights at the road junctions can be optimized, and accordingly vehicle traffic ability can be increased.

No. of Pages : 20 No. of Claims : 6

(12) PATENT APPLICATION PUBLICATION

(21) Application
No.201911050683 A

(19) INDIA

(22) Date of filing of Application :09/12/2019

(43) Publication Date :
20/12/2019

(54) Title of the invention : BIODIESEL COMPOSITION AND A METHOD OF PREPARATION THEREOF

(51)
International :C11C0003000000,C12P0007640000,C10L0001020000,C08K0005000000,C11C0001080000
classification
(31) Priority
Document :NA
No
(32) Priority :NA
Date
(33) Name
of priority :NA
country
(86)
International
Application :NA
No :NA
Filing
Date
(87)
International : NA
Publication
No
(61) Patent
of Addition
to
Application :NA
Number :NA
Filing
Date
(62)
Divisional to
Application :NA
Number :NA
Filing
Date

(71)**Name of Applicant :**
1)Dr. Siddharth Jain
Address of Applicant
:Associate Professor,
Department of
Mechanical Engineering,
College of Engineering
Roorkee, 7th Km,
Roorkee-Haridwar Road,
Vardhman Puram,
Roorkee-247667,
Uttarakhand, India.
Uttarakhand India
2)Akshay Garg
(72)**Name of Inventor :**
1)Akshay Garg
2)Dr. Siddharth Jain

(57) Abstract :

The present invention relates to a biodiesel composition comprising (i) a Jatropha curcas powder and spirogyra powder in a ratio of 1:1 (w/w), (ii) Sodium hydroxide in the range of 0-5% w/w and (iii) methanol in the range of 8%-20% v/v. The method for preparing biodiesel composition comprising the following steps: (i) mixing dry powder of Jatropha curcas seeds and spirogyra to obtain a mixture with low free fatty acid content and reduced degree of unsaturation of said Jatropha curcas, (ii) adding sodium hydroxide, n-hexane and methanol in said mixture to catalyze free fatty acid content mixture, and (iii) subjecting said mixture to in-situ transesterification reaction at 50 °C at a time varying from 60 minutes to 180 minutes to obtain a biodiesel composition

No. of Pages : 20 No. of Claims : 8

(12) PATENT APPLICATION PUBLICATION

(21) Application
No.201911050696 A

(19) INDIA

(22) Date of filing of Application :09/12/2019

(43) Publication Date :
20/12/2019

(54) Title of the invention : Early detection of breast cancer with dynamically scrapped prescription on mobile device.

<p>(51) International :G06T0007000000,G06N0003040000,G06N0003080000,G06K0009000000,G06K0009620000 classification (31) Priority Document :NA No (32) Priority :NA Date (33) Name of priority :NA country (86) International Application :PCT// No :01/01/1900 Filing Date (87) International Publication : NA No (61) Patent of Addition to Application :NA Number :NA Filing Date (62) Divisional to Application :NA Number :NA Filing Date</p>	<p>(71)Name of Applicant : 1)Ashok Kumar Address of Applicant :House 214, Mahadevi 2nd, Banasthali Vidyapith Campus, Banasthali, Tonk, Raj Rajasthan India 2)Prof.Saurabh Mukherjee (72)Name of Inventor : 1)Ashok Kumar 2)Prof.Saurabh Mukherjee</p>
---	---

(57) Abstract :

Growth of a cell in life is controlled by its nucleus or centroid but when this centroid behaves abnormally then results in abnormal growth of cell. This fitful growth of a cell is exponential and invades as a cancerous part of the body. Objective of this work is to deliver a classification system that can that can predict class of multi class malignancy with prescription as per class predicted and mining dynamic content from web using web scrapping library of Android. This work also prescribes details like time taken, degree of seriousness, probability of curing by opted treatment because treatment of a breast cancer depends on type and stage of malignancy with early detection of malignancy with Android interface to end users. This is a concrete effort using advances of soft computing like deep learning and deep neural networks, image processing and web mining to abate breast cancer mortality by achieving higher or clinical usage accuracy in an early stage breast cancer detection.

No. of Pages : 0 No. of Claims : 0

(12) PATENT APPLICATION PUBLICATION

(21) Application
No.201911050729 A

(19) INDIA

(22) Date of filing of Application :09/12/2019

(43) Publication Date :
20/12/2019

(54) Title of the invention : AN IOT BASED SMART DEVICE FOR ANIMAL TRACKING

(51)
International :A01K0015020000,G06K0009000000,A01K0027000000,H04W0004900000,G01S0019350000
classification
(31) Priority
Document :NA
No
(32) Priority :NA
Date
(33) Name
of priority :NA
country
(86)
International
Application :NA
No :NA
Filing
Date
(87)
International
Publication : NA
No
(61) Patent
of Addition
to
Application :NA
Number :NA
Filing
Date
(62)
Divisional to
Application :NA
Number :NA
Filing
Date

(71)**Name of Applicant :**
1)Lovely Profesional University
Address of Applicant :Lovely Profesional University, Delhi Jalandhar GT road Phagwara-144411. Punjab India
(72)**Name of Inventor :**
1)Rajesh Singh
2)Anita Gehlot
3)Danvir Mandal
4)Arbinda Kumar Prasad

(57) Abstract :

The present invention is related to IoT based smart device for Animal Tracking so as to help various organizations and agencies to track the animals so as they can find the animals which goes out of range (specified by the user). The device is fitted with GPS module (104), magnetometer (101), Temperature and humidity sensor, all connected to the microcontroller (102) and a battery (99).

No. of Pages : 10 No. of Claims : 7

(12) PATENT APPLICATION PUBLICATION

(21) Application
No.201911050730 A

(19) INDIA

(22) Date of filing of Application :09/12/2019

(43) Publication Date :
20/12/2019

(54) Title of the invention : A DEVICE OF SMART GUIDE SYSTEM FOR INDOOR NAVIGATION

(51)
International :G01S0005020000,G01C0021200000,A61H0003060000,H04W0064000000,G01S0001680000
classification
(31) Priority
Document :NA
No
(32) Priority :NA
Date
(33) Name
of priority :NA
country
(86)
International
Application :NA
No :NA
Filing
Date
(87)
International : NA
Publication
No
(61) Patent
of Addition
to
Application :NA
Number :NA
Filing
Date
(62)
Divisional to
Application :NA
Number :NA
Filing
Date

(71)Name of Applicant
:
**1)Lovely Profesional
University**
Address of
Applicant :Lovely
Profesional University,
Delhi Jalandhar GT road
Phagwara- 144411.
Punjab India
(72)Name of Inventor :
**1)Dr. Anita Gehlot
2)Dr Rajesh Singh
3)Manoj Singh
Adhikari
4)Chinelli Hruthik
5)Dr. Govind Singh**

(57) Abstract :

Disclosed herein a hand held small device which is given to a visitor or a new person(unfamiliar with the surrounding) in a indoor space will provide the clear details of every important location inside the space, if a new person walks in, this device can guide the person with the route and places of certain rooms and other details. This device is like a GPS for indoor local spaces, a person with this device can easily navigate in the defined indoor space. The guided navigation of terrain and outside locations is easily achieved by the use of GPS. The localized guidance of internal spaces is not achieved by any system as standardized such as a GPS system. The localization can be easily achieved by the proposed system will address the localization of internal spaces like inside of a buildings and manmade structures.

No. of Pages : 16 No. of Claims : 5

(12) PATENT APPLICATION PUBLICATION

(21) Application
No.201911050731 A

(19) INDIA

(22) Date of filing of Application :09/12/2019

(43) Publication Date :
20/12/2019

(54) Title of the invention : HEALTH MONITORING SYSTEM OF SOLAR PANELS

(51)
International :H04L0029080000,H02S0050100000,H02S0050000000,H01L0031020000,H04W0084180000
classification
(31) Priority
Document :NA
No
(32) Priority
Date :NA
(33) Name
of priority :NA
country
(86)
International
Application :NA
No :NA
Filing
Date
(87)
International
Publication : NA
No
(61) Patent
of Addition
to
Application :NA
Number :NA
Filing
Date
(62)
Divisional to
Application :NA
Number :NA
Filing
Date

(71)Name of Applicant
:
**1)Lovely Professional
University**
Address of Applicant
:Lovely Professional
University, Delhi
Jalandhar GT road
Phagwara- 144411.
Punjab India
(72)Name of Inventor :
**1)Dr Rajesh Singh
2)Dr. Anita Gehlot
3)Shaikh Vaseem
Akram**

(57) Abstract :

The invention relates to the health monitoring of individual solar panel. In this, the solar panels are embedded with the acquisition node for identifying the fault detection in solar panels. For identifying the fault, the acquisition node comprises of voltage sensor, current sensor, humidity sensor, temperatures sensor, solar radiation intensity sensor. This sensor values are transmitted to nearby gateway node with the assistance of LoRa communication. The received sensed data will be uploaded to the cloud server with the assistance of Wi-Fi. Through cloud server, the industries can access the sensor data of the solar panel without visiting the location of solar panel frequently.

No. of Pages : 13 No. of Claims : 6

(12) PATENT APPLICATION PUBLICATION

(21) Application
No.201911050732 A

(19) INDIA

(22) Date of filing of Application :09/12/2019

(43) Publication Date :
20/12/2019

(54) Title of the invention : AN IOT BASED SOUND CONTROLLED SMART DEVICE FOR WATER SPRINKLING

(51)
International :A01G0025160000,B05B0001300000,A62C0035680000,B05B0003040000,A01G0025090000
classification
(31) Priority
Document :NA
No
(32) Priority :NA
Date
(33) Name
of priority :NA
country
(86)
International
Application :NA
No :NA
Filing
Date
(87)
International
Publication : NA
No
(61) Patent
of Addition
to
Application :NA
Number :NA
Filing
Date
(62)
Divisional to
Application :NA
Number :NA
Filing
Date

(71)**Name of Applicant**
:
**1)Lovely Profesional
University**
Address of
Applicant :Lovely
Professional University,
Delhi Jalandhar GT road
Phagwara- 144411.
Punjab India
(72)**Name of Inventor :**
1)Mahendra Swain
2)Rajesh Singh
3)Anita Gehlot
4)Rakesh Kumar

(57) Abstract :

The present invention related to an IoT based Sound controlled smart device for water sprinkling. The present invention aims at design an IoT enabled sprinkler for precise irrigation at field. Sprinkler is equipped with advance controller and control valve. Sprinkler can be switch on and off from by sending message. Further scheduling timer helps the sprinkler to decide time of operation.

No. of Pages : 10 No. of Claims : 4

(12) PATENT APPLICATION PUBLICATION

(21) Application
No.201911050733 A

(19) INDIA

(22) Date of filing of Application :09/12/2019

(43) Publication Date :
20/12/2019

(54) Title of the invention : CLOUD BASED SMART MONITORING SYSTEM AND CONTROLLING OF STREET LIGHT

(51)
International :H05B0037020000,H04N0001000000,H04L0012660000,H04W0004020000,F21S0008080000
classification

(31) Priority
Document :NA
No

(32) Priority
Date :NA

(33) Name
of priority :NA
country

(86)
International
Application :NA
No :NA

Filing
Date

(87)
International
Publication : NA
No

(61) Patent
of Addition
to
Application :NA
Number :NA

Filing
Date

(62)
Divisional to
Application :NA
Number :NA

Filing
Date

(71)**Name of Applicant**
:
**1)Lovely Profesional
University**

Address of
Applicant :Lovely
Profesional University,
Delhi Jalandhar GT road
Phagwara- 144411.
Punjab India

(72)**Name of Inventor :**

1)Dr Rajesh Singh
2)Dr. Anita Gehlot
**3)Shaikh Vaseem
Akram**
4)Harpreet Singh
5)Dr. Lovi Raj Gupta

(57) Abstract :

A system is designed for real time health monitoring of the street light using RF and LoRa communication. The proposed system is integration of wireless street light controller, nearby controller unit, RF communication, LoRa communication, street light gateway, and cloud server. RF communication based controller unit is embedded to the lamp so that the controller unit monitoring the different parameters of the light. The data related to the lamp is communicated to the nearby controller unit via RF communication. Now controller unit transmits the data to the gateway node through LoRa (Long Range) communication for avoiding the problem of long range connectivity issues. The gateway node verifies the data and upload the data to the cloud server with the assistance.

No. of Pages : 7 No. of Claims : 10

(12) PATENT APPLICATION PUBLICATION

(21) Application
No.201911050735 A

(19) INDIA

(22) Date of filing of Application :09/12/2019

(43) Publication Date :
20/12/2019

(54) Title of the invention : INTERNET OF THINGS (IOT) AND LORA NETWORK BASED NOISE MONITORING AND CONTROL SYSTEM

(51)
International :H04L0029080000,G08B0021180000,G05B0019048000,H04W0024020000,A01M0031000000
classification
(31) Priority
Document :NA
No
(32) Priority :NA
Date
(33) Name
of priority :NA
country
(86)
International
Application :NA
No :NA
Filing
Date
(87)
International : NA
Publication
No
(61) Patent
of Addition
to
Application :NA
Number :NA
Filing
Date
(62)
Divisional to
Application :NA
Number :NA
Filing
Date

(71)**Name of Applicant :**
1)Lovely Profesional University
Address of Applicant :Lovely Profesional University, Delhi Jalandhar GT road Phagwara- 144411. Punjab India
(72)**Name of Inventor :**
1)Dr Rajesh Singh
2)Dr. Anita Gehlot
3)Shaikh Vaseem Akram

(57) Abstract :

The present invention is related to the monitoring of noise level of any field with geo location. LoRa (Long Range) based wireless communication is integrated in our system for communicating to long range. Proposed system comprises of noise level monitoring mote, local data collector, and gateway and cloud server. Noise level monitoring mote collects the sound level of any location with geo mapping. The collected data is sent to local data collector via RF modem. The local data collector aggregate the data received from the mote and communicate it to the gateway through LoRa (Long Range) modem. The received data is uploaded to cloud server via Wi-Fi modem for analyzing and monitoring of sound level of field. A cloud server based mobile app is developed and through the graphical user interface, the noise level of any location is monitored.

No. of Pages : 14 No. of Claims : 10

(12) PATENT APPLICATION PUBLICATION

(21) Application
No.201911050737 A

(19) INDIA

(22) Date of filing of Application :09/12/2019

(43) Publication Date :
20/12/2019

(54) Title of the invention : A SYSTEM FOR HOME AUTOMATION BASE ON HYBRID GSM-GPRS AND PLCC

(51)
International :H04L0012280000,H04B0003540000,G05B0015020000,H02J0013000000,H04W0004700000
classification
(31) Priority
Document :NA
No
(32) Priority :NA
Date
(33) Name
of priority :NA
country
(86)
International
Application :NA
No :NA
Filing
Date
(87)
International
Publication : NA
No
(61) Patent
of Addition
to
Application :NA
Number :NA
Filing
Date
(62)
Divisional to
Application :NA
Number :NA
Filing
Date

(71)**Name of Applicant**
:
**1)Lovely Professional
University**
Address of Applicant
:Lovely Professional
University, Delhi
Jalandhar GT road
Phagwara- 144411.
Punjab India
(72)**Name of Inventor :**
1)Dr Rajesh Singh
2)Dr. Anita Gehlot
**3)Shaikh Vaseem
Akram**

(57) Abstract :

The present invention is related to a system for home automation base on Hybrid GSM-GPRS and PLCC. In present invention a home automation system is proposed for controlling the appliance of home through Power Line Carrier Communication and it is shown in figure 1. The system comprises of transmitter end and receiver end. A mobile app is used for controlling the appliance via internet. This system is useful where the internet connectivity is available.

No. of Pages : 11 No. of Claims : 5

(12) PATENT APPLICATION PUBLICATION

(21) Application
No.201911050738 A

(19) INDIA

(22) Date of filing of Application :09/12/2019

(43) Publication Date :
20/12/2019

(54) Title of the invention : AN IOT ENABLED SYSTEM FOR PLANT HEALTH MONITORING SYSTEM AND IMAGE PROCESSING

(51)
International :G06T0007000000,B67D0001080000,H04N0007180000,H04L0029080000,A01N0063000000
classification
(31) Priority
Document :NA
No
(32) Priority :NA
Date
(33) Name
of priority :NA
country
(86)
International
Application :NA
No :NA
Filing
Date
(87)
International : NA
Publication
No
(61) Patent
of Addition
to
Application :NA
Number :NA
Filing
Date
(62)
Divisional to
Application :NA
Number :NA
Filing
Date

(71)**Name of Applicant**
:
1)Lovely Professional University
Address of
Applicant :Lovely
Professional University,
Delhi Jalandhar GT road
Phagwara- 144411.
Punjab India
(72)**Name of Inventor :**
1)Dr Rajesh Singh
2)Dr. Anita Gehlot
3)Navjot Rathore
4)Prabin Kumar Das
5)Bishwajyoti Roy
6)Vaishnavi Gupta

(57) Abstract :

The present invention is related to IoT enabled system for plant health monitoring and Image Processing. The present invention also helps farmers who are unable to identify the problems regarding plants in day to day life. The aim of this project is to interface the camera with raspberry and raspberry pi is coded with the python to capture images and calculating NDVI and then through VNC viewer software the results are sent to the user which helps them to differentiate between healthy and non-healthy plants by applying machine learning on dataset. Plant Health monitoring is one of the most important tasks in any agriculture-based environment. India is one of the nations where agriculture and allied sectors are major employment sources. Thus, an efficient monitoring system is required for continuous and long-term plant health monitoring.

No. of Pages : 12 No. of Claims : 7

(12) PATENT APPLICATION PUBLICATION

(21) Application
No.201911050739 A

(19) INDIA

(22) Date of filing of Application :09/12/2019

(43) Publication Date :
20/12/2019

(54) Title of the invention : AN IOT BASED SYSTEM FOR FOREST FIRE DETECTION AND SURVEILLANCE

(51)
International :G08B0017000000,G08B0017120000,H04N0007180000,A62C0003020000,G06F0011200000
classification
(31) Priority
Document :NA
No
(32) Priority :NA
Date
(33) Name
of priority :NA
country
(86)
International
Application :NA
No :NA
Filing
Date
(87)
International
Publication : NA
No
(61) Patent
of Addition
to
Application :NA
Number :NA
Filing
Date
(62)
Divisional to
Application :NA
Number :NA
Filing
Date

(71)**Name of Applicant**
:
**1)Lovely Professional
University**
Address of Applicant
:Lovely Professional
University, Delhi
Jalandhar GT road
Phagwara- 144411.
Punjab India
(72)**Name of Inventor :**
1)Dr. Rajesh Singh
**2)Dr. Amit Kumar
Thakur**
3)Dr. Anita Gehlot
4)Prabin Kumar Das
5)Vaishnavi Gupta
**6)Shaikh Vaseem
Akram**

(57) Abstract :

The present invention describes a forest surveillance and monitoring system for the early detection of falling of trees, poaching, trading of trees, landslides and reporting of forest fires in a forest area. The system of the present invention composed of a main server, head and node. All the nodes are connected to the head in a range of 2km (approximation) which is then connected to the main server. If there is any situation of fire, landslide, illegal poaching/cutting of tree, in this case the node will sense the frequent changes and will be transmitted to the head. Then head will transmit those signals to the main server in control room, which can be used to take necessary steps & to mitigate the disaster from happening.

No. of Pages : 16 No. of Claims : 7

(12) PATENT APPLICATION PUBLICATION

(21) Application
No.201911050823 A

(19) INDIA

(22) Date of filing of Application :09/12/2019

(43) Publication Date :
20/12/2019

(54) Title of the invention : AN ESPRESSO EMULSIFICATION METHOD FOR SYNTHESIS OF UNIFORM HOLLOW POLYMER NANOPARTICLES

(51)
International :B82Y0030000000,A61K0041000000,A61K0009510000,B01J0013140000,A61K0031704000
classification

(31) Priority
Document :NA
No

(32) Priority :NA
Date

(33) Name
of priority :NA
country

(86)
International
Application :NA
No :NA

Filing
Date

(87)
International : NA
Publication
No

(61) Patent
of Addition
to
Application :NA
Number :NA
Filing

Date

(62)
Divisional to
Application :NA
Number :NA
Filing

Date

(71)**Name of Applicant**
:
**1)Indian Institute of
Technology Kanpur**

Address of Applicant
:Dean, Research &
Development, Room
Number 151, Faculty
Building, Post Office:
IIT Kanpur, Kanpur,
Uttar Pradesh - 208016,
India Uttar Pradesh India

(72)**Name of Inventor :**
1)Pranav Joshi
2)Archana Raichur

(57) Abstract :

The present disclosure provides for a process for synthesis of drug-encapsulated in hollow polymer nanoparticles. The process includes preparation and mixing of a first phase solution and second phase solution to form espresso emulsion. The espresso emulsion being added to the lukewarm distilled water and stirred to obtain a resultant emulsion. The process further includes centrifugation of an aliquot collected from the resultant emulsion and separation of the bottom phase to obtain the drug-encapsulated in hollow polymer nanoparticles. The hollow polymer nanoparticle comprises average size of 25nm. The process provides the nanoparticles that can secure the drug, control the release without losing the drug activity, circulate in blood for long period of time, increase the efficiency of drug and reduce the problems with patient compliances. The process provides the polymer nanoparticles which do not affect the pharmacokinetics of drug when encapsulated and release the drug at particular target cell.

No. of Pages : 13 No. of Claims : 6

(12) PATENT APPLICATION PUBLICATION

(21) Application
No.201911050872 A

(19) INDIA

(22) Date of filing of Application :09/12/2019

(43) Publication Date :
20/12/2019

(54) Title of the invention : INTERNET OF THINGS BASED LOW COST DIGITAL SIGNAL OSCILLOSCOPE SYSTEM

(51)
International :H01M0004587000,G06K0009000000,G01R0013020000,G06Q0050180000,A61K0047600000
classification

(31) Priority
Document :NA
No

(32) Priority :NA
Date

(33) Name
of priority :NA
country

(86)
International
Application :NA
No :NA

Filing
Date

(87)
International : NA
Publication
No

(61) Patent
of Addition
to
Application :NA
Number :NA
Filing

Date

(62)
Divisional to
Application :NA
Number :NA
Filing

Date

(71)Name of
Applicant :
**1)Sandeep Singh
Jagdev**
Address of
Applicant :Ellen
Technology Pvt. Ltd.,
India Punjab India
2)Vikram Puri
**3)Raghvendra
Kumar**
**4)Ishaani
Priyadarshini**
5)Rohit Sharma
**6)Brojo Kishore
Mishra**
**7)Chandrakanta
Mahanty**
8)Souvik Pal
9)Chung Van Le
(72)Name of Inventor
:
**1)Sandeep Singh
Jagdev**
2)Vikram Puri
**3)Raghvendra
Kumar**
**4)Ishaani
Priyadarshini**
5)Rohit Sharma
**6)Brojo Kishore
Mishra**
**7)Chandrakanta
Mahanty**
8)Souvik Pal
9)Chung Van Le

(57) Abstract :

The present invention disclosure is related to the internet of things based low cost digital signal oscilloscope system. The objective of the present invention to overcome the inadequacies of the prior art in digital signal oscilloscope.

No. of Pages : 22 No. of Claims : 6

(54) Title of the invention : MP-DETECTION: MEDICAL PROBLEMS DETECTION USING MACHINE LEARNING TECHNIQUES

(51) International :G16H0030400000,G16H0050200000,G06K0009460000,G06K0009620000,G06T0007000000 classification
 (31) Priority Document :NA
 No
 (32) Priority Date :NA
 (33) Name of priority :NA
 country
 (86) International Application :NA
 No :NA
 Filing Date
 (87) International Publication :NA
 No
 (61) Patent of Addition to Application :NA
 Number :NA
 Filing Date
 (62) Divisional to Application :NA
 Number :NA
 Filing Date

(71)Name of Applicant :
1)DR. HARI OM SHARAN
 Address of Applicant :RAMA UNIVERSITY RAMA CITY, MANDHANA, KANPUR (UTTAR PRADESH) - 209 217, INDIA Uttar Pradesh India
2)PRABU S
3)C GOWDHAM
4)DR. PUTTI SRINIVASARAO
5)DR. B. INDIRA
6)DR. ABHIJIT NARAYANRAO BANUBAKODE
7)SUSHAMA RANI DUTTA
8)GILLALA REKHA
 (72)Name of Inventor :
1)DR. HARI OM SHARAN
2)PRABU S
3)C GOWDHAM
4)DR. PUTTI SRINIVASARAO
5)DR. B. INDIRA
6)DR. ABHIJIT NARAYANRAO BANUBAKODE
7)SUSHAMA RANI DUTTA
8)GILLALA REKHA

(57) Abstract :
 My invention MP-Detection Systems and methods for processing electronic imaging, normal image data obtained from medical imaging procedures are disclosed herein. Some embodiments relate to data processing mechanisms for medical imaging and diagnostic workflows involving the use of machine learning techniques such as deep learning, artificial neural networks, and related algorithms that perform machine recognition of specific advanced features and conditions in imaging data. In an invention, a deep learning model is selected for automated image recognition of a particular medical condition on image data, and applied to the image data to recognize characteristics of the particular medical condition. Based on the characteristics recognized by the automated image recognition on the image data, an electronic workflow for performing a diagnostic evaluation of the medical imaging study may be modified, updated, or prioritized.

No. of Pages : 25 No. of Claims : 6

(12) PATENT APPLICATION PUBLICATION

(21) Application
No.201911051145 A

(19) INDIA

(22) Date of filing of Application :11/12/2019

(43) Publication Date :
20/12/2019

(54) Title of the invention : AN IOT BASED INTELLIGENT SYSTEM FOR GARBAGE COLLECTION

(51)
International :G06F0012020000,G09B0019000000,G06F0008610000,G02F0001133500,H04N0009040000
classification
(31) Priority
Document :NA
No
(32) Priority :NA
Date
(33) Name
of priority :NA
country
(86)
International
Application :NA
No :NA
Filing
Date
(87)
International
Publication : NA
No
(61) Patent
of Addition
to
Application :NA
Number :NA
Filing
Date
(62)
Divisional to
Application :NA
Number :NA
Filing
Date

(71)**Name of Applicant :**
**1)Lovely Profesional
University**
Address of Applicant
:Lovely Profesional
University, Delhi
Jalandhar GT road
Phagwara- 144411.
Punjab India
(72)**Name of Inventor :**
**1)Dr. Ashutosh
Sharma**
2)Dr. Sakshi Aneja
**3)Dr. Neeta Raj
Sharma**
**4)Mr. Yeluri Sessa
Choudary**

(57) Abstract :

The present invention is related to an IoT based intelligent system for Garbage Collection. The present invention includes a series of ultrasonic motion sensors, a high-resolution camera, biosensors, a microprocessor unit and three multi-colored bins. The three colors of the bins are Green (for organic), Red (for inorganic) and yellow (for Plastic). The color coding and the no. of bins will depend upon the location as well as the diverse form of garbage produced. During the time of installation, a data base of diversified garbage produced.

No. of Pages : 10 No. of Claims : 2

(12) PATENT APPLICATION PUBLICATION

(21) Application
No.201911051146 A

(19) INDIA

(22) Date of filing of Application :11/12/2019

(43) Publication Date :
20/12/2019

(54) Title of the invention : PIPE BLOCKADE DETECTION SYSTEM

(51)
International :G01N003500000,G06F0009540000,B82Y0010000000,B62M0006450000,G01M0003040000
classification
(31) Priority
Document :NA
No
(32) Priority :NA
Date
(33) Name
of priority :NA
country
(86)
International
Application :NA
No :NA
Filing
Date
(87)
International : NA
Publication
No
(61) Patent
of Addition
to
Application :NA
Number :NA
Filing
Date
(62)
Divisional to
Application :NA
Number :NA
Filing
Date

(71)**Name of Applicant :**
1)Lovely Professional University
Address of Applicant :Lovely Professional University, Delhi Jalandhar GT road Phagwara-144411. Punjab India
(72)**Name of Inventor :**
1)Dr. Ashutosh Sharma
2)Dr. Sakshi Aneja
3)Dr. Neeta Raj Sharma
4)Yeluri Sessa Choudary

(57) Abstract :

Disclosed herein a pipe Blockade Detection System comprises a microcontroller (101), LCD Monitor with keypad (102), Battery (103), V-unit (104), I unit (105), and a sensor strip (106). The present invention is related to a Pipe Blockade Detection System. The pipes which are used for liquid transportation has been faced the problem of blockade. To detect the location of blockade lot of time and effort which leads to delay of work, this choke detector is designed to minimize the time and effort.

No. of Pages : 10 No. of Claims : 7

(12) PATENT APPLICATION PUBLICATION

(21) Application
No.201911051147 A

(19) INDIA

(22) Date of filing of Application :11/12/2019

(43) Publication Date :
20/12/2019

(54) Title of the invention : SMART WARDROBE WITH DRESS SUGGESTION

(51)
International :B60S0001080000,A47B0061000000,G08B0021040000,A45C0013020000,E05F0015710000
classification

(31) Priority
Document :NA
No

(32) Priority
Date :NA

(33) Name
of priority :NA
country

(86)
International
Application :NA
No :NA

Filing
Date

(87)
International
Publication : NA
No

(61) Patent
of Addition
to
Application :NA
Number :NA

Filing
Date

(62)
Divisional to

Application :NA
Number :NA

Filing
Date

(71)Name of Applicant :
**1)Lovely Profesional
University**

Address of Applicant
:Lovely Profesional
University, Delhi
Jalandhar GT road
Phagwara- 144411.
Punjab India

(72)Name of Inventor :

- 1)Rajesh Singh**
- 2)Swapnil Bagwari**
- 3)Anita Gehlot**
- 4)Saurabh Gain**
- 5)Lovi Raj Gupta**

(57) Abstract :

A smart wardrobe system with dress suggestion comprises of two units, first unit called Outside weather monitoring system (100), consists of Microcontroller (101), various sensors like rain sensor (106), light sensor (102), DHT11 sensor (105) and altitude sensor (107) and RF module (108). The wardrobe mostly serves as storage for clothes; these clothes may be dirty or clean. It also serves as a storage area for various other articles such as jewellery, shoes, etc. Owners interact with the wardrobe as often as they would like in order to find something appropriate to wear for instance to go to work, dinner party, etc.

No. of Pages : 11 No. of Claims : 5

(12) PATENT APPLICATION PUBLICATION

(21) Application
No.201911051149 A

(19) INDIA

(22) Date of filing of Application :11/12/2019

(43) Publication Date :
20/12/2019

(54) Title of the invention : A SYSTEM OF IOT TRIGGERED NOTIFICATION AND LAMP CONTROL OF VEHICLES

(51)
International :B60Q0001140000,B60Q0001000000,H04W0004700000,B60Q0001340000,B23K0026060000
classification
(31) Priority
Document :NA
No
(32) Priority :NA
Date
(33) Name
of priority :NA
country
(86)
International
Application :NA
No :NA
Filing
Date
(87)
International
Publication : NA
No
(61) Patent
of Addition
to
Application :NA
Number :NA
Filing
Date
(62)
Divisional to
Application :NA
Number :NA
Filing
Date

(71)**Name of Applicant**
:
**1)Lovely Profesional
University**
Address of
Applicant :Lovely
Profesional University,
Delhi Jalandhar GT
road Phagwara-
144411. Punjab India
(72)**Name of Inventor**
:
**1)Dushyant Kumar
Singh**
2)P Raja
3)Himani Jerath
4)Kanwaljeet Singh

(57) Abstract :

The present invention discloses a system of IoT triggered notification and lamp control of vehicle. People forget to switch OFF the headlight and parking light when they are leaving their vehicle in the daytime (mostly in winters). A system of IoT triggered notification and lamp control of vehicle comprises Head light sensor, Car engine ON/OFF status signal, Actuator to control ON/OFF status of head light, and IoT Notification module. This drains the battery badly and kills the battery. The vehicle can't be started after it. And it even reduces the life of the battery. This is the major problem faced by people in the fast-growing world. A report says, around 40 percentage of the battery replacement in vehicles is due to the wastage of charges from the battery.

No. of Pages : 11 No. of Claims : 3

(12) PATENT APPLICATION PUBLICATION

(21) Application
No.201911051150 A

(19) INDIA

(22) Date of filing of Application :11/12/2019

(43) Publication Date :
20/12/2019

(54) Title of the invention : A SENSOR BASED SECURITY SYSTEM FOR BUILDINGS

(51)
International :E04G0021320000,H04L0029060000,A62B0001200000,G08B0013120000,A63G0031000000
classification
(31) Priority
Document :NA
No
(32) Priority
Date :NA
(33) Name
of priority :NA
country
(86)
International
Application :NA
No :NA
Filing
Date
(87)
International
Publication : NA
No
(61) Patent
of Addition
to
Application :NA
Number :NA
Filing
Date
(62)
Divisional to
Application :NA
Number :NA
Filing
Date

(71)**Name of Applicant**
:
**1)Lovely Professional
University**
Address of Applicant
:Lovely Professional
University, Delhi
Jalandhar GT road
Phagwara- 144411.
Punjab India
(72)**Name of Inventor :**
1)Mandeep Singh

(57) Abstract :

The present invention is related to a sensor based security system for buildings. A Safety System is invented to save people falling from height from balconies accidentally and even intentionally done by others. The system will consist of long iron string based , which will be installed at 2nd, 3rd floor of the building. These String sensors will be connected directly to the control and trigger unit, and if any continuity is there due to sensor wire striking, it will immediately opens the flap of 15 feet installed at 1st floor consists of bungee jumping material and net. The person who falls will get save by this sensor.

No. of Pages : 11 No. of Claims : 4

(12) PATENT APPLICATION PUBLICATION

(21) Application
No.201911051151 A

(19) INDIA

(22) Date of filing of Application :11/12/2019

(43) Publication Date :
20/12/2019

(54) Title of the invention : FINGERPRINT BASED TEMPLE DONATION BOX

(51)
International :G06F0021440000,H04L0009320000,E05B0015160000,E05B0017000000,E05B0047000000
classification

(31) Priority
Document :NA
No

(32) Priority
Date :NA

(33) Name
of priority :NA
country

(86)
International
Application :NA
No :NA

Filing
Date

(87)
International
Publication : NA
No

(61) Patent
of Addition
to
Application :NA
Number :NA

Filing
Date

(62)
Divisional to

Application :NA
Number :NA

Filing
Date

(71)Name of Applicant :
**1)Lovely Professional
University**

Address of Applicant
:Lovely Professional
University, Delhi
Jalandhar GT road
Phagwara- 144411.
Punjab India

(72)Name of Inventor :
**1)Mandeep Singh
2)Ruhul Amin
Choudhury
3)Manish Kotni**

(57) Abstract :

The proposed invention is smart locking and security assembly for temple donation box, which consists of setup for temple donation box. The donation box is made up of metal which consists of desired number of solenoids these are used for the locking of the container these are secure that no external agency can be destroy it. This proposed model has high end security unit that which is 100% efficient that no one can open it without the authentication. The box is designed in such a way that theft cannot be done as no outer lock is there which can be broken or whose duplicate key can be produced.

No. of Pages : 12 No. of Claims : 6

(12) PATENT APPLICATION PUBLICATION

(21) Application
No.201911051152 A

(19) INDIA

(22) Date of filing of Application :11/12/2019

(43) Publication Date
: 20/12/2019

(54) Title of the invention : A DEVICE OF SPECTACLES FOR BLINKING EYES

(51)
International :H04W0080040000,H04W0084180000,H04W0088060000,A61B0005110000,H04M0019040000
classification

(31) Priority
Document :NA
No

(32) Priority
Date :NA

(33) Name
of priority :NA
country

(86)
International
Application :NA
No :NA

Filing
Date

(87)
International
Publication : NA
No

(61) Patent
of Addition
to
Application :NA
Number :NA

Filing
Date

(62)
Divisional to
Application :NA
Number :NA

Filing
Date

(71)**Name of
Applicant :**
**1)Lovely
Professional
University**

Address of
Applicant :Lovely
Professional
University, Delhi
Jalandhar GT road
Phagwara- 144411.
Punjab India

(72)**Name of
Inventor :**
**1)Mandeep Singh
2)Ruhul Amin
Choudhury
3)Manish Kotni**

(57) Abstract :

The present invention is a smart spectacle which can sense the frequency of the eye blinking based on the threshold value. If the threshold value is exceeded, the device gives the notification to the vibrator which is embedded on the spectacles. The same notification is also sent by the Bluetooth protocol to the mobile, then mobile produces vibration to gain the attention of the person.

No. of Pages : 9 No. of Claims : 4

(12) PATENT APPLICATION PUBLICATION

(21) Application
No.201911051153 A

(19) INDIA

(22) Date of filing of Application :11/12/2019

(43) Publication Date :
20/12/2019

(54) Title of the invention : A DEVICE OF IR KEYBOARD WITH CHARACTER GENERATED VOICE

(51)
International :G06F0003023000,G06K0017000000,A63F0009060000,H03K0017969000,G09B0019020000
classification
(31) Priority
Document :NA
No
(32) Priority
Date :NA
(33) Name
of priority :NA
country
(86)
International
Application :NA
No :NA
Filing
Date
(87)
International
Publication : NA
No
(61) Patent
of Addition
to
Application :NA
Number :NA
Filing
Date
(62)
Divisional to
Application :NA
Number :NA
Filing
Date

(71)**Name of Applicant**
:
**1)Lovely Professional
University**
Address of Applicant
:Lovely Professional
University, Delhi
Jalandhar GT road
Phagwara- 144411.
Punjab India
(72)**Name of Inventor :**
**1)Dushyant Kumar
Singh**
2)Himani Jerath
3)P Raja
4)Kanwaljeet Singh

(57) Abstract :

The present invention is related to a IR Keyboard with character generated voice. The present invention further relates to a device having matrix infrared based keyboard for kids learning. The keyboard will not be having any of the mechanical part thus increasing the overall life of the system. A device of IR Keyboard with character generated voice comprises IR sensors arranged in the matrix form; Processing board to scan respective rows and columns; Speaker system to announce that particular character. The sensors present in the proposed device are arranged in the form of rows and columns.

No. of Pages : 9 No. of Claims : 4

(12) PATENT APPLICATION PUBLICATION

(21) Application
No.201911051154 A

(19) INDIA

(22) Date of filing of Application :11/12/2019

(43) Publication Date :
20/12/2019

(54) Title of the invention : A LORA AND IOT BASED DEVICE TO MONITOR THE DAM

(51)
International :G05D0009120000,H04Q0011040000,H04W0024000000,A01G0025160000,G01F0001000000
classification
(31) Priority
Document :NA
No
(32) Priority :NA
Date
(33) Name
of priority :NA
country
(86)
International
Application :NA
No :NA
Filing
Date
(87)
International : NA
Publication
No
(61) Patent
of Addition
to
Application :NA
Number :NA
Filing
Date
(62)
Divisional to
Application :NA
Number :NA
Filing
Date

(71)**Name of Applicant :**
1)Lovely Profesional University
Address of Applicant :Lovely Profesional University, Delhi Jalandhar GT road Phagwara-144411. Punjab India
(72)**Name of Inventor :**
1)Dr Rajesh Singh
2)Dr. Anita Gehlot
3)Shaikh Vaseem Akram
4)Lovi Raj Gupta
5)Amit Kumar Thakur

(57) Abstract :

The present invention provides a novel architecture constantly monitors the water level in the dam. Whenever water level rises drastically in any river/lake, the system decides when to open the dam and for how much duration. This decision is taken based on the information collected by the sensors placed in reservoirs.

No. of Pages : 15 No. of Claims : 4

(12) PATENT APPLICATION PUBLICATION

(21) Application
No.201911051155 A

(19) INDIA

(22) Date of filing of Application :11/12/2019

(43) Publication Date :
20/12/2019

(54) Title of the invention : A DEVICE OF SMART ELECTRIC EXTENSION BOARD

(51)
International :G06F0003023000,A63F0009060000,H03K0017969000,G06K0017000000,G09B0019020000
classification
(31) Priority
Document :NA
No
(32) Priority :NA
Date
(33) Name
of priority :NA
country
(86)
International
Application :NA
No :NA
Filing
Date
(87)
International : NA
Publication
No
(61) Patent
of Addition
to
Application :NA
Number :NA
Filing
Date
(62)
Divisional to
Application :NA
Number :NA
Filing
Date

(71)**Name of Applicant**
:
**1)Lovely Professional
University**
Address of Applicant
:Lovely Professional
University, Delhi
Jalandhar GT road
Phagwara- 144411.
Punjab India
(72)**Name of Inventor :**
**1)Dushyant Kumar
Singh**
2)Himani Jerath
3)Kanwaljeet Singh
4)P Raja

(57) Abstract :

The present invention is related to a IR Keyboard with character generated voice. The present invention further relates A device is invented having matrix infrared based keyboard for kids learning. The keyboard will not be having any of the mechanical part thus increasing the overall life of the system. A device of IR Keyboard with character generated voice comprises IR sensors arranged in the matrix form; Processing board to scan respective rows and columns; Speaker system to announce that particular character. The sensors present in the proposed device are arranged in the form of rows and columns.

No. of Pages : 11 No. of Claims : 4

(12) PATENT APPLICATION PUBLICATION

(21) Application
No.201911051156 A

(19) INDIA

(22) Date of filing of Application :11/12/2019

(43) Publication Date :
20/12/2019

(54) Title of the invention : SMART GESTURE GENERATION SYSTEM FOR DEAF PEOPLE

(51)
International :G06N0020000000,G06K0009000000,H04N0021414000,G06Q0020060000,G09B0021040000
classification

(31) Priority
Document :NA
No

(32) Priority
Date :NA

(33) Name
of priority :NA
country

(86)
International
Application :NA
No :NA

Filing
Date

(87)
International
Publication : NA
No

(61) Patent
of Addition
to
Application :NA
Number :NA

Filing
Date

(62)
Divisional to

Application :NA
Number :NA

Filing
Date

(71)Name of Applicant
:

**1)Lovely Profesional
University**
Address of
Applicant :Lovely
Profesional University,
Delhi Jalandhar GT
road Phagwara- 144411.
Punjab India

(72)Name of Inventor :

**1)Rydhm Beri
2)Anita Gehlot
3)Mithilesh Kr
Dubey
4)Rajesh Singh**

(57) Abstract :

There are various issues faced by deaf person to live in the society. The major and common issues include the difficulty in understanding of language. The present invention is related to a smart gesture generation system (101) for deaf people comprises various components viz. (104,105,106,107,108); wherein (104) is the processing element where the machine learning algorithm performs the required tasks.

No. of Pages : 11 No. of Claims : 4

(12) PATENT APPLICATION PUBLICATION

(21) Application
No.201911051157 A

(19) INDIA

(22) Date of filing of Application :11/12/2019

(43) Publication Date :
20/12/2019

(54) Title of the invention : SMART CONTROLLER FOR PIPELINE MONITORING ROBOT

(51)
International :G06Q0010060000,G06T0015000000,G01N0027820000,G01N0017000000,G01M0003000000
classification
(31) Priority
Document :NA
No
(32) Priority :NA
Date
(33) Name
of priority :NA
country
(86)
International
Application :NA
No :NA
Filing
Date
(87)
International
Publication : NA
No
(61) Patent
of Addition
to
Application :NA
Number :NA
Filing
Date
(62)
Divisional to
Application :NA
Number :NA
Filing
Date

(71)**Name of Applicant :**
1)Lovely Profesional University
Address of Applicant :Lovely Profesional University, Delhi Jalandhar GT road Phagwara-144411. Punjab India
(72)**Name of Inventor :**
1)Chavala Lakshmi Narayana
2)Rajesh Singh
3)Anita Gehlot
4)Lovi Raj Gupta

(57) Abstract :

Corrosion is a major problem throughout oil and gas industry. It is not only the petrochemical, power and manufacturing industries which is affected, but can occur wherever pipelines are fitted with thermal insulation. In this system an IoT based Smart robot for the pipeline inspection. It will acquires the damage occurred by the artificial or natural damage conditions during construction and clashes. The acquired data is sent to an server using LoRa communication protocol.

No. of Pages : 14 No. of Claims : 7

(12) PATENT APPLICATION PUBLICATION

(21) Application
No.201911051159 A

(19) INDIA

(22) Date of filing of Application :11/12/2019

(43) Publication Date :
20/12/2019

(54) Title of the invention : ARTIFICIAL INTELLIGENCE ENABLED PIT HOLE DETECTION AND FILLING SYSTEM FOR ROAD

(51)
International :G08C0023040000,G08G0001140000,H01M0002360000,G06K0009440000,H04N0007180000
classification
(31) Priority
Document :NA
No
(32) Priority :NA
Date
(33) Name
of priority :NA
country
(86)
International
Application :NA
No :NA
Filing
Date
(87)
International : NA
Publication
No
(61) Patent
of Addition
to
Application :NA
Number :NA
Filing
Date
(62)
Divisional to
Application :NA
Number :NA
Filing
Date

(71)**Name of Applicant :**
1)Lovely Profesional University
Address of Applicant :Lovely Profesional University, Delhi Jalandhar GT road Phagwara- 144411. Punjab India
(72)**Name of Inventor :**
1)Rajesh Singh
2)Anita Gehlot
3)Prabin Kumar Das
4)Sheik Vaseem Akram
5)Vaishnavi Gupta

(57) Abstract :

The present invention discloses A system of Artificial Intelligence enabled pit hole detection and filling system for road comprises Vehicle with robotic probe (101), analyzing unit (102), image processing unit (103), a cloud server (104), and a display unit (105). The present invention is related to a system of Artificial Intelligence enabled pit hole detection and filling system for road. This system is able to measure the approximate dimension of the pit hole using image processing which processes the image of the pithole and then send this data to the dedicated server and fill the pithole with accurate amount of concrete.

No. of Pages : 13 No. of Claims : 6

(12) PATENT APPLICATION PUBLICATION

(21) Application
No.201911051160 A

(19) INDIA

(22) Date of filing of Application :11/12/2019

(43) Publication Date :
20/12/2019

(54) Title of the invention : A SYSTEM OF NEURO ANALYTICAL SIGNAL BASED RESCUE INDICATOR

(51)
International :G08B0021020000,G08B0027000000,H04W0004000000,A44C0005000000,G08B0005000000
classification
(31) Priority
Document :NA
No
(32) Priority :NA
Date
(33) Name
of priority :NA
country
(86)
International
Application :NA
No :NA
Filing
Date
(87)
International
Publication : NA
No
(61) Patent
of Addition
to
Application :NA
Number :NA
Filing
Date
(62)
Divisional to
Application :NA
Number :NA
Filing
Date

(71)**Name of Applicant**
:
**1)Lovely Profesional
University**
Address of
Applicant :Lovely
Profesional University,
Delhi Jalandhar GT
road Phagwara-
144411. Punjab India
(72)**Name of Inventor**
:
**1)Dr. Anita Gehlot
2)Dr Rajesh Singh
3)Dr. Lovi Raj
Gupta**

(57) Abstract :

The present invention is related to a system of neuro analytical signal based rescue indicator. This device is very much helpful for any woman. Because when a woman is in danger position then it alerts the predefined numbers. By simply wearing a wrist band it sends alert and the message with the location. This device is helpful in any problem arises in travelling or any kind of danger situations.

No. of Pages : 12 No. of Claims : 7

(12) PATENT APPLICATION PUBLICATION

(21) Application
No.201911051161 A

(19) INDIA

(22) Date of filing of Application :11/12/2019

(43) Publication Date :
20/12/2019

(54) Title of the invention : AN INTELLIGENT MEDICINE BOTTLE DEVICE

(51)
International :A61J0007040000,A61J0001200000,A61J0001160000,G01N0033530000,A61J0001060000
classification
(31) Priority
Document :NA
No
(32) Priority
Date :NA
(33) Name
of priority :NA
country
(86)
International
Application :NA
No :NA
Filing
Date
(87)
International
Publication : NA
No
(61) Patent
of Addition
to
Application :NA
Number :NA
Filing
Date
(62)
Divisional to
Application :NA
Number :NA
Filing
Date

(71)Name of Applicant :
**1)Lovely Profesional
University**
Address of Applicant
:Lovely Professional
University, Delhi Jalandhar
GT road Phagwara-
144411. Punjab India
(72)Name of Inventor :
**1)Piyush Gulati
2)Rajesh Singh
3)Jai Inder Preet Singh
4)Satnam Singh**

(57) Abstract :

The present invention is related to IoT based Intelligent Medicine bottle device. The present invention is a device which is invented for measuring the atmospheric temperature and humidity to be maintained for a medicine bottle, especially liquid medicine. The need is to identify the temperature and humidity levels of the medicine stored in the bottle. The device includes a DHT11 sensor for measuring temperature and humidity and provide signal to the controller that provides signal to the LED display. Further the signal is provided on mobile app through WiFi.

No. of Pages : 10 No. of Claims : 6

(12) PATENT APPLICATION PUBLICATION

(21) Application
No.201911051162 A

(19) INDIA

(22) Date of filing of Application :11/12/2019

(43) Publication Date :
20/12/2019

(54) Title of the invention : AN INTEGRATED SYSTEM FOR HEALTH MONITORING AND BIOMETRIC ATTENDANCE

(51)
International :G06Q0010100000,G07C0001100000,A61B0005000000,G09B0007000000,G07C0001140000
classification
(31) Priority
Document :NA
No
(32) Priority
Date :NA
(33) Name
of priority :NA
country
(86)
International
Application :NA
No :NA
Filing
Date
(87)
International
Publication : NA
No
(61) Patent
of Addition
to
Application :NA
Number :NA
Filing
Date
(62)
Divisional to
Application :NA
Number :NA
Filing
Date

(71)**Name of Applicant**
:
**1)Lovely Professional
University**
Address of
Applicant :Lovely
Professional University,
Delhi Jalandhar GT road
Phagwara- 144411.
Punjab India
(72)**Name of Inventor :**
**1)Dr. Manpreet
Singh**
2)Piyush Gulati
**3)Jai Inder Preet
Singh**
4)Dr Rajesh Singh
5)Dr. Satnam Singh
6)Sandeep Singh

(57) Abstract :

The present invention is related to an IoT based Integrated System for Health monitoring and biometric attendance. Many organizations are using biometric data logger (BDL) for recording the attendance (date and time) of their employees. This device in addition will record the weight of their employees by weight measuring unit (WMU) and through radio frequency communication module (RFCM) it will pass the information to BDL. The BDL will display the data on the display unit and will record it on to the cloud server. This will keep the record of weight of every employee along with date for the purpose of monitoring health condition.

No. of Pages : 12 No. of Claims : 6

(12) PATENT APPLICATION PUBLICATION

(21) Application
No.201911051163 A

(19) INDIA

(22) Date of filing of Application :11/12/2019

(43) Publication Date :
20/12/2019

(54) Title of the invention : AN INTELLIGENT RAILWAY CROSSING SYSTEM TO AVOID ACCIDENTS

(51)
International :B61L0029040000,H04W0004700000,B61L0029240000,B61L0029160000,B61L0029020000
classification
(31) Priority
Document :NA
No
(32) Priority :NA
Date
(33) Name
of priority :NA
country
(86)
International
Application :NA
No :NA
Filing
Date
(87)
International
Publication : NA
No
(61) Patent
of Addition
to
Application :NA
Number :NA
Filing
Date
(62)
Divisional to
Application :NA
Number :NA
Filing
Date

(71)**Name of Applicant**
:
**1)Lovely Profesional
University**
Address of Applicant
:Lovely Profesional
University, Delhi
Jalandhar GT road
Phagwara- 144411.
Punjab India
(72)**Name of Inventor :**
**1)Dushyant Kumar
Singh**
2)P Raja
3)Kanwaljeet Singh
4)Himani Jerath

(57) Abstract :

The proposed system is to monitor the arrival of train on railway crossing at least 1 to 2 Km before. The railway line will be installed with a proximity sensor and IoT enabled processing board to monitor and report the status. Apart from reporting the status the system will send the control signal module nearby the crossing gate for its closure. Sensing and notifying the arrival of train before 1 -2 KM or more will ensure that the crossing gate in closed on time. This also reduces the wait time of the daily commutations also.

No. of Pages : 13 No. of Claims : 6

(12) PATENT APPLICATION PUBLICATION

(21) Application
No.201911051164 A

(19) INDIA

(22) Date of filing of Application :11/12/2019

(43) Publication Date :
20/12/2019

(54) Title of the invention : AN IOT ENABLED SYSTEM FOR MONITORING OF DANDRUFF€™S LEVEL

(51)
International :A61Q0005000000,G06T0007110000,A61B0090000000,G06Q0020380000,G06F0003000000
classification
(31) Priority
Document :NA
No
(32) Priority :NA
Date
(33) Name
of priority :NA
country
(86)
International
Application :NA
No :NA
Filing
Date
(87)
International : NA
Publication
No
(61) Patent
of Addition
to
Application :NA
Number :NA
Filing
Date
(62)
Divisional to
Application :NA
Number :NA
Filing
Date

(71)**Name of Applicant**
:
**1)Lovely Professional
University**
Address of Applicant
:Lovely Professional
University, Delhi
Jalandhar GT road
Phagwara- 144411.
Punjab India
(72)**Name of Inventor :**
**1)Mr. Prashant
Kumar**
**2)Mahesh Kumar
Prajapat**
3)Dr Rajesh Singh
4)Dr. Anita Gehlot
5)Dr. Lovi Raj Gupta
6)Suverna Sengar

(57) Abstract :

The present invention is related to an IOT enabled System for monitoring of dandruffs level. The present invention monitors the level of dandruff in the hair on our scalp. The device capture the image of the affected area by using the camera and send the data for further processing to tensor processing unit, where its statistical analysis and classification is done and the processed data is send to the cloud serve which further can be collected and displayed on the user mobile phone app.

No. of Pages : 11 No. of Claims : 4

(12) PATENT APPLICATION PUBLICATION

(21) Application
No.201911051165 A

(19) INDIA

(22) Date of filing of Application :11/12/2019

(43) Publication Date :
20/12/2019

(54) Title of the invention : A SMART COLLAPSIBLE STICK DEVICE TO PREVENT STRAY AND WILD ANIMALS USING ULTRASOUND

(51)
International :A01M0029180000,A61H0003060000,B01F0011020000,A01M0001080000,A45B0009000000
classification
(31) Priority
Document :NA
No
(32) Priority :NA
Date
(33) Name
of priority :NA
country
(86)
International
Application :NA
No :NA
Filing
Date
(87)
International : NA
Publication
No
(61) Patent
of Addition
to
Application :NA
Number :NA
Filing
Date
(62)
Divisional to
Application :NA
Number :NA
Filing
Date

(71)**Name of Applicant :**
1)Lovely Profesional University
Address of Applicant :Lovely Profesional University, Delhi Jalandhar GT road Phagwara-144411. Punjab India
(72)**Name of Inventor :**
1)Dr. Lovi Raj Gupta
2)Mahesh Kumar Prajapat
3)Prashant Kumar
4)Dr Rajesh Singh
5)Dr. Anita Gehlot

(57) Abstract :

The present invention is a Smart Collapsible Stick (SCS) device which helps to negate the all type of attacks from stray dogs, snakes and from insects likes honey bees etc., SCS equipped with ultrasonic sound wave generators which produces burst of ultrasonic waves which are distasteful to snakes, dogs and other harmful insects like honeybees. SCS is totally user-friendly, easily maintainable and it provide safer path for any trackers or elderly person on the move during morning walk or stroll.

No. of Pages : 10 No. of Claims : 8

(12) PATENT APPLICATION PUBLICATION

(21) Application
No.201911051419 A

(19) INDIA

(22) Date of filing of Application :12/12/2019

(43) Publication Date :
20/12/2019

(54) Title of the invention : PEST DETECTION AND CONTROL SYSTEM IN SMART FARMING USING IOT

(51)
International :A01M0001100000,A01M0031000000,A01M0023000000,A01M0007000000,A01M0025000000
classification
n
(31) Priority
Document :NA
No
(32) Priority :NA
Date
(33) Name
of priority :NA
country
(86)
International
Application :PCT//
No :01/01/1900
Filing
Date
(87)
International : NA
Publication
No
(61) Patent
of Addition
to
Application :NA
Number :NA
Filing
Date
(62)
Divisional to
Application :NA
Number :NA
Filing
Date

(71)Name of
Applicant :
1)Dr. Shivani Joshi
Address of
Applicant
:Department of
Computer Science &
Engineering,GLBITM
, Greater Noida Uttar
Pradesh India
**2)Dr. Avinash
Dwivedi**
**3)Dr. Vikas
Chaudhary**
4)Dr. Pankaj Singh
(72)Name of
Inventor :
1)Dr. Shivani Joshi
**2)Dr. Avinash
Dwivedi**
**3)Dr. Vikas
Chaudhary**
4)Dr. Pankaj Singh

(57) Abstract :

The disclosure relates to an agricultural system, which comprises a plurality of IoT based crop monitoring and pest control system for growing plants in large fields, wherein, the invention discloses a modern agricultural automatic insect and pest monitoring and early warning system based on IoT, sensor devices and cloud computing. The method combines a cloud server, a smart interactive device/phone, and a plurality of sensors and LED trap lamps. The trap lamps consist of rainproof covers, LED lamp bodies, insect and pest receiving devices, and dual-layer dense high-voltage wire network fences; the rainproof covers are arranged above the LED lamp bodies; the insect and rodent capturing devices are arranged below the LED lamp bodies; and the dual-layer dense high-voltage fences are arranged at peripheries of the LED lamp bodies. Furthermore, the monitoring and control of the whole farmland can be processed monitored precisely through devices such as personal computer and smart phones.

No. of Pages : 16 No. of Claims : 6

(12) PATENT APPLICATION PUBLICATION

(21) Application
No.201911051585 A

(19) INDIA

(22) Date of filing of Application :12/12/2019

(43) Publication Date :
20/12/2019

(54) Title of the invention : AUTOMATIC UNIVERSAL LPG STOVE CONTROL DEVICE FOR BOILING OF LIQUIDS

(51)
International :F24C0015100000,F24C0003120000,A47J0027560000,F28F0013180000,A47J0027000000
classification
(31) Priority
Document :NA
No
(32) Priority :NA
Date
(33) Name
of priority :NA
country
(86)
International
Application :PCT//
No :01/01/1900
Filing
Date
(87)
International
Publication : NA
No
(61) Patent
of Addition
to
Application :NA
Number :NA
Filing
Date
(62)
Divisional to
Application :NA
Number :NA
Filing
Date

(71)Name of Applicant :
1)DR.SATNAM SINGH
Address of Applicant
:THE NORTHCAP
UNIVERSITY,
GURUGRAM-122017,
INDIA e-mail:
satnamsingh@ncuindia.edu
Haryana India
2)MR. RITIK BHATIA
3)DR. ESHA JAIN
4)MS. TARANDEEP
KAUR BHATIA
5)DR. PARDEEP
KUMAR
(72)Name of Inventor :
1)DR.SATNAM SINGH
2)MR. RITIK BHATIA
3)DR. ESHA JAIN
4)MS. TARANDEEP
KAUR BHATIA
5)DR. PARDEEP
KUMAR

(57) Abstract :

AUTOMATIC UNIVERSAL LPG STOVE CONTROL DEVICE FOR BOILING OF LIQUIDS ABSTRACT As per The Economic Times survey, 89% of Indian population still uses conventional LPG gas stoves for cooking purposes and other required purpose. The problem of boiling of liquids such as milk, tea etc. is a very common process in every house. This boiling of liquids over the utensils leads to the wastage of materials as well as wastage of energy resources (LPG) and sometimes can lead to severe accidents in case of liquid spillage over the burner. Still there are no smart burners available which can automatically stop the LPG supply when liquid gets boiled. This invented device will help in overcoming this problem; where the sensor at a particular height in the utensil will trigger the gas knob to off position.

No. of Pages : 18 No. of Claims : 9

(12) PATENT APPLICATION PUBLICATION

(21) Application
No.201911052242 A

(19) INDIA

(22) Date of filing of Application :17/12/2019

(43) Publication Date :
20/12/2019

(54) Title of the invention : A METHOD OF TOUGHENING OF CARBON-JUTE HYBRID COMPOSITES WITH FISHBONE POWDER AND USES THEREOF

(51)
International :B32B0015010000,C08J0005000000,B32B0005260000,G01N0003440000,B29C0070500000
classification

(31) Priority
Document :NA
No

(32) Priority :NA
Date

(33) Name
of priority :NA
country

(86)
International
Application :PCT//
No :01/01/1900

Filing
Date
(87)
International : NA
Publication
No

(61) Patent
of Addition
to
Application :NA
Number :NA

Filing
Date
(62)
Divisional to
Application :NA
Number :NA
Filing
Date

(71)Name of Applicant :
1)Dr. N.K. BATRA
Address of Applicant

:Maharishi
Markandeshwar
Engineering College,
Maharishi
Markandeshwar (Deemed
to be University),
MullanaAmbala, Haryana
Haryana India

2)Ms. ITI DIKSHIT
**3)Mr. HARSIMRAN
SINGH**

(72)Name of Inventor :
1)Dr. N.K. BATRA
2)Ms. ITI DIKSHIT
**3)Mr. HARSIMRAN
SINGH**

(57) Abstract :

This invention provides the details regarding the fabrication and testing of hybrid jute/carbon polymer composite with addition of fishbone as nano filler material which has been explored the first time. The mechanical properties were compared with carbon/jute hybrid polymer composite with and without filler material i.e., fishbone. The hybrid reinforced composites with fishbone powder show better mechanical properties as compared to composites fabricated without filler. Tensile strength varies from 34.91 MPa to 140.82 MPa, flexural strength varies from 66.43 MPa to 166.09 MPa, and Rockwell Hardness of the composites varies from 2.9 HRC to 35 HRC, as a function of fiber volume fraction. Adding the filler in hybrid reinforced composites shows improvement in tensile strength by a maximum of 7.06%. The tensile test, flexural test, and Rockwell Hardness is carried using ASTM D638, ASTM D790, and ASTM D785 respectively.

No. of Pages : 15 No. of Claims : 9

(12) PATENT APPLICATION PUBLICATION

(21) Application
No.201911052243 A

(19) INDIA

(22) Date of filing of Application :17/12/2019

(43) Publication Date :
20/12/2019

(54) Title of the invention : A DYNAMIC ELBOW GONIOMETER DEVICE

<p>(51) International :A61B0005110000,A61B0005000000,A61F0005010000,A41D0013080000,A63B0069000000 classification (31) Priority Document :NA No (32) Priority :NA Date (33) Name of priority :NA country (86) International Application :PCT// No :01/01/1900 Filing Date (87) International Publication : NA No (61) Patent of Addition to Application :NA Number :NA Filing Date (62) Divisional to Application :NA Number :NA Filing Date</p>	<p>(71)Name of Applicant : 1)SHIKSHA Address of Applicant :Maharishi Markandeshwar Institute of Physiotherapy and Rehabilitation, Maharishi Markandeshwar (Deemed to be University), MullanaAmbala, Haryana Haryana India 2)MUSKAN RATHEE 3)NEHA PANJA 4)Dr. MANU GOYAL 5)Dr. N.K. BATRA (72)Name of Inventor : 1)NEHA PANJA 2)SHIKSHA 3)MUSKAN RATHEE 4)Dr. N.K. BATRA 5)Dr. MANU GOYAL</p>
---	--

(57) Abstract :

The invention relates to a dynamic elbow goniometer it is used for measuring the range of motion occurred at elbow joint during performing various activities of daily living. It comprises of cuffs used to fit over the arm of the wearer with one end and the forearm on the other end with two adjoining Goniometer. Two cuffs (arm and forearm) are fixed with the help of Velcro straps. These two goniometer are placed at inner side and outer side of the elbow joint. Outer goniometer asses the functional range and provide visual feedback to subject and inner goniometer is used to assess the functional range by the examiner.

No. of Pages : 14 No. of Claims : 7

(12) PATENT APPLICATION PUBLICATION

(21) Application
No.201911052265 A

(19) INDIA

(22) Date of filing of Application :17/12/2019

(43) Publication Date :
20/12/2019

(54) Title of the invention : SOLAR POWERED COST EFFECTIVE AIR PURIFIER SYSTEM WITH NATURAL FILTERS

(51)
International :G01N0015060000,B01D0046240000,G01N0001220000,A62B0018000000,F21S0009030000
classification
(31) Priority
Document :NA
No
(32) Priority :NA
Date
(33) Name
of priority :NA
country
(86)
International
Application :PCT//
No :01/01/1900
Filing
Date
(87)
International
Publication : NA
No
(61) Patent
of Addition
to
Application :NA
Number :NA
Filing
Date
(62)
Divisional to
Application :NA
Number :NA
Filing
Date

(71)**Name of Applicant**
:
**1)Lovely Profesional
University**
Address of Applicant
:Lovely Profesional
University, Delhi
Jalandhar GT road
Phagwara- 144411.
Punjab India
(72)**Name of Inventor :**
**1)Dushyant Kumar
Singh**
2)Himani Jerath
3)P Raja
**4)Narenthira Prasath
D**

(57) Abstract :

The present invention discloses herein the solar powered air filter that measures the PPM content of the air and based on the air quality, the air passes through a set of filters and the air is purified. The present invention consists of a microcontroller, Wi-Fi modem, sensors, motors, solar panel, LED and LCD display and utilizes natural filters made up with Chrysopogon zizanioides, basically known as vetiver to filters all the micro and macro particles from the atmosphere.

No. of Pages : 8 No. of Claims : 6

(12) PATENT APPLICATION PUBLICATION

(21) Application
No.201911052266 A

(19) INDIA

(22) Date of filing of Application :17/12/2019

(43) Publication Date :
20/12/2019

(54) Title of the invention : A PORTABLE WATER PURIFIER

(51)
International :C02F0001000000,C02F0009000000,C02F0001440000,C02F0001320000,C02F0001760000
classification
(31) Priority
Document :NA
No
(32) Priority :NA
Date
(33) Name
of priority :NA
country
(86)
International
Application :PCT//
No :01/01/1900
Filing
Date
(87)
International
Publication : NA
No
(61) Patent
of Addition
to
Application :NA
Number :NA
Filing
Date
(62)
Divisional to
Application :NA
Number :NA
Filing
Date

(71)**Name of Applicant :**
**1)Lovely Professional
University**
Address of Applicant
:Lovely Professional
University, Jalandhar-
Delhi GT road Phagwara-
144411. Punjab India
(72)**Name of Inventor :**
1)PIYUSH GULATI
**2)Dr. MANPREET
SINGH**
**3)Dr. SATNAM
SINGH**
**4)JAIINDER PREET
SINGH**
5)Dr. RAJESH SINGH
6)SANDEEP SINGH

(57) Abstract :

A novel portable water purifier which consists of plurality of compartments, a filtration unit and a battery with motor for uniform operations. The purifier is detachable and reassembled anywhere.

No. of Pages : 12 No. of Claims : 5

(12) PATENT APPLICATION PUBLICATION

(21) Application
No.201911052267 A

(19) INDIA

(22) Date of filing of Application :17/12/2019

(43) Publication Date :
20/12/2019

(54) Title of the invention : A HERBAL CIGARETTE FOR CURING EPILEPTIC SEIZURES

(51)
International :A61K0036530000,A61K0036670000,A61K0036220000,A61K0036580000,A61K0036185000
classification
(31) Priority
Document :NA
No
(32) Priority :NA
Date
(33) Name
of priority :NA
country
(86)
International
Application :PCT//
No :01/01/1900
Filing
Date
(87)
International
Publication : NA
No
(61) Patent
of Addition
to
Application :NA
Number :NA
Filing
Date
(62)
Divisional to
Application :NA
Number :NA
Filing
Date

(71)**Name of Applicant**
:
**1)Lovely Profesional
University**
Address of
Applicant :Lovely
Profesional University,
Delhi Jalandhar GT
road Phagwara-
144411. Punjab India
(72)**Name of Inventor**
:
**1)Pushendra
Kumar Sharma**
2)Vishaldeep Singh
**3)Prashant Kumar
Pandey**
**4)Bishnu Kant
Shukla**

(57) Abstract :

A special herbal cigarette containing various herbs that cure the Epileptic seizures and head ache through smoking. The herbal cigarette is filled with dark colored vegetables leaves such as Piper betle, Ocimum tenuiflorum, Mangifera indica dried in shade, powered and mixed with Cow desi ghee, Ammonia and Calcium Oxide. In the present invention, the smoke when inhaled reaches the blood and provides instant relief from headache, and epilepsy.

No. of Pages : 5 No. of Claims : 5

(12) PATENT APPLICATION PUBLICATION

(21) Application
No.201911052268 A

(19) INDIA

(22) Date of filing of Application :17/12/2019

(43) Publication Date :
20/12/2019

(54) Title of the invention : AN APPARATUS TO PREVENT UPLIFTING OF TRACTORS FROM FRONT SIDE

(51)
International :H04N0005225000,G11B0015675000,B62D0005040000,H01Q0001520000,H01L0023373000
classification
(31) Priority
Document :NA
No
(32) Priority :NA
Date
(33) Name
of priority :NA
country
(86)
International
Application :PCT//
No :01/01/1900
Filing
Date
(87)
International
Publication : NA
No
(61) Patent
of Addition
to
Application :NA
Number :NA
Filing
Date
(62)
Divisional to
Application :NA
Number :NA
Filing
Date

(71)Name of Applicant
:
**1)Lovely Profesional
University**
Address of
Applicant :Lovely
Profesional University,
Jalandhar-Delhi GT
road Phagwara- 144411.
Punjab India
(72)Name of Inventor :
**1)Mandeep Singh
2)Ruhul Amin
Choudhury
3)Harpinder Singh**

(57) Abstract :

The present invention discloses an apparatus to prevent uplifting of tractors from front side whenever heavily loaded. The apparatus consists of a stepper motor (4) with rack and pinion gears (5), a power module (1), metal plate (1) connected through plurality of hinge (6) to tractor and a control unit (3). The metal plate (1) moves horizontally or vertically to apply load on front tyres of the tractor which in-turn neutralize the tilt-angle. The apparatus is simple, cheap and cost-effective.

No. of Pages : 8 No. of Claims : 2

(12) PATENT APPLICATION PUBLICATION

(21) Application
No.201911052269 A

(19) INDIA

(22) Date of filing of Application :17/12/2019

(43) Publication Date :
20/12/2019

(54) Title of the invention : A SMART MULTILEVEL PARKING SYSTEM USING RFID

(51)
International :G07F0009020000,G08G0001140000,G07F0011620000,G07B0015040000,G07F0011000000
classification
(31) Priority
Document :NA
No
(32) Priority :NA
Date
(33) Name
of priority :NA
country
(86)
International
Application :PCT//
No :01/01/1900
Filing
Date
(87)
International
Publication : NA
No
(61) Patent
of Addition
to
Application :NA
Number :NA
Filing
Date
(62)
Divisional to
Application :NA
Number :NA
Filing
Date

(71)**Name of Applicant :**
**1)Lovely Profesional
University**
Address of Applicant
:Lovely Profesional
University, Delhi
Jalandhar GT road
Phagwara- 144411.
Punjab India
(72)**Name of Inventor :**
**1)Dushyant Kumar
Singh**
2)Kanwaljeet Singh
3)P Raja
4)Himani Jerath
5)Bodhraj

(57) Abstract :

The present invention discloses herein a smart parking system which consists of a RFID vending machine, a RFID scanner, a processing unit, a power unit, buzzer and display unit. Here, the RFID tag vending machine control the whole process of the invention. In the present system, after the RFID tag is issued by the vending machine, the information related to level of the parking and the slot is displayed on the display unit. At the exit, the RFID tag is collected by the machine, which will help to know the vacant spaces all over the parking area.

No. of Pages : 8 No. of Claims : 6

(12) PATENT APPLICATION PUBLICATION

(21) Application
No.201911052270 A

(19) INDIA

(22) Date of filing of Application :17/12/2019

(43) Publication Date :
20/12/2019

(54) Title of the invention : INTELLIGENT TRAFFIC CONTROL AND MAINTENANCE SYSTEM USING HYBRID COMMUNICATION

(51)
International :H04W0028020000,G02B0006420000,H04B0005000000,B60W0030140000,G08G0005000000
classification

(31) Priority
Document :NA
No

(32) Priority :NA
Date

(33) Name
of priority :NA
country

(86)
International
Application :PCT//
No :01/01/1900

Filing
Date
(87)
International : NA
Publication
No

(61) Patent
of Addition
to
Application :NA
Number :NA
Filing

Date
(62)
Divisional to
Application :NA
Number :NA
Filing
Date

(71)**Name of Applicant :**
1)Lovely Professional University
Address of Applicant :Lovely Professional University, Delhi Jalandhar GT road Phagwara- 144411. Punjab India
(72)**Name of Inventor :**
1)Rajan Miglani

(57) Abstract :

A novel system for traffic control wherein the system works on communication module using RFID , transmission module for transferring information and mapping module for real time monitoring.

No. of Pages : 9 No. of Claims : 5

(12) PATENT APPLICATION PUBLICATION

(21) Application
No.201911052271 A

(19) INDIA

(22) Date of filing of Application :17/12/2019

(43) Publication Date :
20/12/2019

(54) Title of the invention : A NOVEL SYSTEM FOR TOLL PLAZAS

(51)
International :H04W0024000000,G08G0001017000,H04N0005247000,H01M0008043800,H05B0003000000
classification
(31) Priority
Document :NA
No
(32) Priority :NA
Date
(33) Name
of priority :NA
country
(86)
International
Application :PCT//
No :01/01/1900
Filing
Date
(87)
International : NA
Publication
No
(61) Patent
of Addition
to
Application :NA
Number :NA
Filing
Date
(62)
Divisional to
Application :NA
Number :NA
Filing
Date

(71)**Name of Applicant :**
1)Lovely Professional University
Address of Applicant :Lovely Professional University, Jalandhar-Delhi GT road Phagwara- 144411. Punjab India
(72)**Name of Inventor :**
1)Dr. SAKSHI ANEJA
2)Dr. NEETA RAJ SHARMA
3)YELURI SESA CHAUDARY
4)Dr.ASHUTOSH SHARMA

(57) Abstract :

A novel artificial intelligence based system which consists of real time monitoring of traffic and control using multiple cameras in synchronization. This system makes the travelling on high ways more easy and convenient.

No. of Pages : 10 No. of Claims : 6

(12) PATENT APPLICATION PUBLICATION

(21) Application
No.201911052491 A

(19) INDIA

(22) Date of filing of Application :18/12/2019

(43) Publication Date :
20/12/2019

(54) Title of the invention : DEEP LEARNING BASED MEDICINAL PLANT DISEASE IDENTIFICATION

(51)
International :G06T0007000000,G06K0009620000,G16H0050700000,G06K0009000000,A61B0001000000
classification
(31) Priority
Document :NA
No
(32) Priority :NA
Date
(33) Name
of priority :NA
country
(86)
International
Application :PCT//
No :01/01/1900
Filing
Date
(87)
International : NA
Publication
No
(61) Patent
of Addition
to
Application :NA
Number :NA
Filing
Date
(62)
Divisional to
Application :NA
Number :NA
Filing
Date

(71)Name of Applicant
:
**1)Lovely
Professional University**
Address of
Applicant :Lovely
Professional University,
Jalandhar-Delhi GT
road Phagwara- 144411.
Punjab India
(72)Name of Inventor :
**1)Dr.ANITA
GEHLOT
2)BHAVESH
KUMAR
CHOITHRAM
DHARMANI
3)GITTALAY
DHINGRA
4)Rajesh Singh**

(57) Abstract :

A system for deep learning based medicinal plant disease detection wherein the system consists of image processing, data acquisition, preprocessing, feature extraction and classification. The features are analyzed based on data acquired from images taken from plant.

No. of Pages : 13 No. of Claims : 5

(12) PATENT APPLICATION PUBLICATION

(21) Application
No.201911052493 A

(19) INDIA

(22) Date of filing of Application :18/12/2019

(43) Publication Date :
20/12/2019

(54) Title of the invention : NON-CONTACT FETAL HEART MONITORING DEVICE USING IMAGE PROCESSING

(51)
International :A61B0005000000,B60R0001000000,G06K0009000000,A61B0008080000,G03B0017560000
classification
(31) Priority
Document :NA
No
(32) Priority :NA
Date
(33) Name
of priority :NA
country
(86)
International
Application :PCT//
No :01/01/1900
Filing
Date
(87)
International
Publication : NA
No
(61) Patent
of Addition
to
Application :NA
Number :NA
Filing
Date
(62)
Divisional to
Application :NA
Number :NA
Filing
Date

(71)**Name of Applicant**
:
**1)Lovely Profesional
University**
Address of
Applicant :Lovely
Professional University,
Delhi Jalandhar GT road
Phagwara- 144411.
Punjab India
(72)**Name of Inventor :**
**1)Bhaveshkumar
Choithram Dharmani**
2)Rajesh Singh
3)Navjot Rathore
4)Anita Gehlot
5)Deepika Ghai

(57) Abstract :

The present invention discloses a device for monitoring fetal heart rate. The present invention consists of a camera and mounting assembly, a controller unit and a display unit. In the present invention, the camera is interfaced with a Raspberry Pi board, which facilitates camera image acquisition and processing for implementing a deep learning algorithm. Raspberry pi is having in-built Wi-Fi unit, which is interfaced with the cloud using IoT and is displayed in the operation theatre or elsewhere through mobile or computer screen

No. of Pages : 10 No. of Claims : 8

(12) PATENT APPLICATION PUBLICATION

(21) Application
No.201911052494 A

(19) INDIA

(22) Date of filing of Application :18/12/2019

(43) Publication Date :
20/12/2019

(54) Title of the invention : A SMART SYSTEM FOR FILE MANAGEMENT

(51)
International :G06K0007100000,G06K0019040000,H04W0004350000,G06F0001180000,B07C0005340000
classification
(31) Priority
Document :NA
No
(32) Priority :NA
Date
(33) Name
of priority :NA
country
(86)
International
Application :PCT//
No :01/01/1900
Filing
Date
(87)
International
Publication : NA
No
(61) Patent
of Addition
to
Application :NA
Number :NA
Filing
Date
(62)
Divisional to
Application :NA
Number :NA
Filing
Date

(71)Name of Applicant
:
**1)Lovely Profesional
University**
Address of
Applicant :Lovely
Profesional University,
Jalandhar-Delhi GT
road Phagwara- 144411.
Punjab India
(72)Name of Inventor :
**1)Prashant Kumar
2)Rajesh Singh
3)Anita Gehlot
4)Mahesh Kumar
Prajapat
5)Suverna Sengar
6)Lovi Raj Gupta**

(57) Abstract :

The present invention discloses a smart system for management and monitoring of files kept in an almirah. The system consists of plurality of file (10), an almirah (9), a cloud server (5), a fog node (2), a camera (1), a bar code scanner, plurality of RFID tag (11), RFID scanner (3), a computing device (6), a power supply unit (8), a data storage unit (4), and IP router (7). The system is based on image capturing and RFID tag.

No. of Pages : 8 No. of Claims : 3

(12) PATENT APPLICATION PUBLICATION

(21) Application
No.201911052495 A

(19) INDIA

(22) Date of filing of Application :18/12/2019

(43) Publication Date :
20/12/2019

(54) Title of the invention : A SYSTEM OF INTEGRATING MOBILE DEVICES FOR WASTE WATER MANAGEMENT

(51)
International :C02F0001000000,G01N0033180000,H04L0029080000,G01N0021770000,A61B0008000000
classification
(31) Priority
Document :NA
No
(32) Priority :NA
Date
(33) Name
of priority :NA
country
(86)
International
Application :PCT//
No :01/01/1900
Filing
Date
(87)
International : NA
Publication
No
(61) Patent
of Addition
to
Application :NA
Number :NA
Filing
Date
(62)
Divisional to
Application :NA
Number :NA
Filing
Date

(71)**Name of Applicant**
:
**1)Lovely Professional
University**
Address of Applicant
:Lovely Professional
University, Delhi
Jalandhar GT road
Phagwara- 144411.
Punjab India
(72)**Name of Inventor :**
1)Neeta Raj Sharma
**2)Yeluri Sesha
Choudary**
3)Rajesh Singh
4)Anita Gehlot
5)Sakshi Aneja
6)Ashutosh Sharma
**7)Shaikh Vaseem
Akram**

(57) Abstract :

The present invention is designed and developed for monitoring and filtering the water quality through cloud server. The system comprises of a microcontroller module, a GPRS (Global Packet for Radio Service) module, an application server and cloud server. Microcontroller unit is embedded with the three different sensor probes like pH sensor, TDS sensor and DO (Dissolved Oxygen) probe. In the present invention, the sensors sense the quality of water and sent it to the cloud server through GPRS communication module.

No. of Pages : 8 No. of Claims : 5

(12) PATENT APPLICATION PUBLICATION

(21) Application
No.201911052496 A

(19) INDIA

(22) Date of filing of Application :18/12/2019

(43) Publication Date :
20/12/2019

(54) Title of the invention : E-WASTE MANAGEMENT BY COMPONENT REMOVAL AND SEGREGATION MACHINE

(51)
International :G06N002000000,G06T0007110000,A61B0005010000,G01N0033000000,A61M0025000000
classification
(31) Priority
Document :NA
No
(32) Priority :NA
Date
(33) Name
of priority :NA
country
(86)
International
Application :PCT//
No :01/01/1900
Filing
Date
(87)
International : NA
Publication
No
(61) Patent
of Addition
to
Application :NA
Number :NA
Filing
Date
(62)
Divisional to
Application :NA
Number :NA
Filing
Date

(71)**Name of Applicant**
:
**1)Lovely
Professional
University**
Address of
Applicant :Lovely
Professional University,
Jalandhar-Delhi GT
road Phagwara-
144411. Punjab India
(72)**Name of Inventor**
:
**1)Dr. SHOBHIT
SAXENA
2)KUNDAN
JADHAO
3)DEEPTI
SHARMA
4)SWAPNIL MORE
5)HARLEEN KAUR
6)Dr. Anita Gehlot
7)HARSHA DEV
SINGH
8)SUMAN LATA
TRIPATHI
9)Rajesh Singh**

(57) Abstract :

A novel system for e-waste segregation wherein the system includes a plurality of sensors, a heating unit, a segregation unit and a collecting unit. The segregation of components is done with the help of camera and machine learning algorithm. The system is trained to segregate the components with the help of pre defined database. The system is more easy to use and can be used by small and local vendors.

No. of Pages : 11 No. of Claims : 5

(12) PATENT APPLICATION PUBLICATION

(21) Application
No.201911052497 A

(19) INDIA

(22) Date of filing of Application :18/12/2019

(43) Publication Date :
20/12/2019

(54) Title of the invention : EMERGENCY TRAFFIC CONTROL AND MANAGEMENT SYSTEM

(51)
International :G08G0001087000,G08G0001096700,A61G0003000000,G08G0001000000,G08G0001080000
classification

(31) Priority
Document :NA
No

(32) Priority
Date :NA

(33) Name
of priority :NA
country

(86)
International
Application :PCT//
No :01/01/1900

Filing
Date
(87)
International
Publication : NA
No

(61) Patent
of Addition
to
Application :NA
Number :NA

Filing
Date
(62)

Divisional to
Application :NA
Number :NA

Filing
Date

(71)**Name of Applicant**
:

**1)Lovely Profesional
University**
Address of
Applicant :Lovely
Profesional University,
Delhi Jalandhar GT
road Phagwara-
144411. Punjab India

(72)**Name of Inventor**
:

**1)Himani Jerath
2)Dushyant Kumar
Singh
3)Saurabh Singh**

(57) Abstract :

The present invention discloses herein an emergency traffic management system using raspberry pi. The present system consists of a Raspberry Pi 3 B+, ESP32 microcontroller, I2C protocol, 162 LCD, blue and red Led and jumper wires. the present system allows the traffic lights to communicate with the ambulance and with each other and guide the ambulance by knowing the distance of the ambulance and the intersection and the traffic density.

No. of Pages : 8 No. of Claims : 6

(12) PATENT APPLICATION PUBLICATION

(21) Application
No.201911052498 A

(19) INDIA

(22) Date of filing of Application :18/12/2019

(43) Publication Date :
20/12/2019

(54) Title of the invention : A ROBOTIC SYSTEM FOR SANITIZING LAMINAR AIR FLOW CHAMBER

(51)
International :B01L0003000000,B01L0001040000,F24F0003160000,B65B0003000000,B08B0015020000
classification
(31) Priority
Document :NA
No
(32) Priority :NA
Date
(33) Name
of priority :NA
country
(86)
International
Application :PCT//
No :01/01/1900
Filing
Date
(87)
International
Publication : NA
No
(61) Patent
of Addition
to
Application :NA
Number :NA
Filing
Date
(62)
Divisional to
Application :NA
Number :NA
Filing
Date

(71)**Name of Applicant :**
**1)Lovely Profesional
University**
Address of Applicant
:Lovely Professional
University, Jalandhar-
Delhi GT road Phagwara-
144411. Punjab India
(72)**Name of Inventor :**
**1)Reena Singh
2)Chirag Chopra
3)Daljeet Singh
Dhanjal**

(57) Abstract :

The present invention discloses a robotic system for sanitizing laminar air flow chamber. The system consists of plurality of motor (106), a belt system (107), a cleaning reagent, a reservoir (105), plurality of pumps, plurality of connecting rod (108), plurality of hollow connecting rod (102), a telescopic channel (103), a spray assembly (101), and a collecting tray (109). The system saves time for cleaning and sterilizing the laminar air flow chamber. The invention the system can be used for biosafety cabinets, clean hoods and fume hoods.

No. of Pages : 9 No. of Claims : 4

(12) PATENT APPLICATION PUBLICATION

(21) Application
No.201911052499 A

(19) INDIA

(22) Date of filing of Application :18/12/2019

(43) Publication Date :
20/12/2019

(54) Title of the invention : A SYSTEM FOR OUTFIT TRIAL THROUGH LIVE USER INPUT

(51)
International :H04L0029080000,H04L0029060000,G06F0003010000,H04M0001725000,G06F0021620000
classification
(31) Priority
Document :NA
No
(32) Priority :NA
Date
(33) Name
of priority :NA
country
(86)
International
Application :PCT//
No :01/01/1900
Filing
Date
(87)
International : NA
Publication
No
(61) Patent
of Addition
to
Application :NA
Number :NA
Filing
Date
(62)
Divisional to
Application :NA
Number :NA
Filing
Date

(71)**Name of Applicant**
:
**1)Lovely Professional
University**
Address of Applicant
:Lovely Professional
University, Delhi
Jalandhar GT road
Phagwara- 144411.
Punjab India
(72)**Name of Inventor :**
1)Reena Singh
2)Lovi Raj Gupta
3)Chirag Chopra
4)Rajesh Singh
5)Putta Bharath
6)Adari Saikumar
7)Daljeet Singh
Dhanjal

(57) Abstract :

The present invention discloses herein an online system for generating a dummy replica by taking the measurement input from the user. The system disclosed consists of a VSB camera for input of user's image, a Raspberry Pi Module, a keyboard and a mouse, a power supply, and a display Screen. In the present invention, users get full access over their virtual image and privacy settings and can try out several outfits at a time with a single session of creating a dummy.

No. of Pages : 8 No. of Claims : 6

(12) PATENT APPLICATION PUBLICATION

(21) Application
No.201911052500 A

(19) INDIA

(22) Date of filing of Application :18/12/2019

(43) Publication Date :
20/12/2019

(54) Title of the invention : A SMART SAFETY JACKET FOR PET

(51)
International :A01K0015020000,G08B0021020000,A61B0005000000,G10L0017220000,A61B0005024000
classification

(31) Priority
Document :NA
No

(32) Priority
Date :NA

(33) Name
of priority :NA
country

(86)
International
Application :PCT//
No :01/01/1900

Filing
Date
(87)
International
Publication : NA
No

(61) Patent
of Addition
to
Application :NA
Number :NA

Filing
Date
(62)
Divisional to
Application :NA
Number :NA
Filing
Date

(71)**Name of Applicant**
:
**1)Lovely Profesional
University**
Address of
Applicant :Lovely
Professional University,
Jalandhar-Delhi GT road
Phagwara- 144411.
Punjab India
(72)**Name of Inventor :**
**1)Sandeep Kumar
Arora**
**2)Kamal Kumar
Sharma**

(57) Abstract :

The present invention discloses a smart safety jacket for pet. The jacket consists of a location tracking system, a heartbeat sensor, a shock sensor, and a first aid solution container. The jacket is easily wearable for pets. Whenever any pet wears the jacket and goes outside of house, the location of the pet is sent to the owner in realtime.

No. of Pages : 8 No. of Claims : 4

(12) PATENT APPLICATION PUBLICATION

(21) Application
No.201917042919 A

(19) INDIA

(22) Date of filing of Application :22/10/2019

(43) Publication Date :
20/12/2019

(54) Title of the invention : INFORMATION PROCESSING METHOD, PROGRAM, AND INFORMATION PROCESSING DEVICE

(51)
International :H04L0029080000,G06Q0050000000,G06Q0010100000,G06N0005020000,H04S0007000000
classification

(31) Priority
Document :2018-236233
No

(32) Priority :18/12/2018
Date

(33) Name
of priority :Japan
country

(86)
International
Application :PCT/JP2019/028620
No :22/07/2019

Filing
Date

(87)
International : NA
Publication
No

(61) Patent
of Addition
to
Application :NA
Number :NA

Filing
Date

(62)
Divisional to
Application :NA
Number :NA

Filing
Date

(71)**Name of Applicant**
:
**1)FINC
TECHNOLOGIES
INC.**

Address of
Applicant :12-1,
Yuraku-cho 1- chome,
Chiyoda-ku, Tokyo
1000006, Japan Japan

(72)**Name of Inventor :**
1)MIZOGUCHI, Yuji
2)KUBOTA, Takuma
Alexander
3)INUKAI,
Toshitaka

(57) Abstract :

The present disclosure relates to communications between users in a community service within a virtual space, and provides an information processing method, a program, and an information processing device which facilitate activating communities through the mediation of a virtual user. In this method, users including an administrator user and a plurality of general users are associated with a virtual user for supporting the users in a community. The method includes the steps, executed by a computer, of generating an event associated with the administrator user and a first general user,- and in response to the generated event, causing the virtual user to generate prompt content for prompting a second general user to communicate with the first general user, and supply the prompt content to the second general user in the community.

No. of Pages : 61 No. of Claims : 10

(12) PATENT APPLICATION PUBLICATION

(21) Application
No.201917045291 A

(19) INDIA

(22) Date of filing of Application :07/11/2019

(43) Publication Date :
20/12/2019

(54) Title of the invention : STRETCH SHEET FOR ABSORBENT ARTICLE AND METHOD FOR PRODUCING THE SAME

(51)
International :A61F0013150000,A61F0013490000,B29C0055180000,A61F0013511000,B32B0007020000
classification

(31) Priority
Document :2018-147827
No

(32) Priority
Date :06/08/2018

(33) Name
of priority :Japan
country

(86)
International
Application :PCT/JP2019/014417
No :01/04/2019

Filing
Date

(87)
International
Publication : NA
No

(61) Patent
of Addition
to
Application :NA
Number :NA

Filing
Date

(62)
Divisional to
Application :NA
Number :NA

Filing
Date

(71)Name of Applicant :
**1)KAO
CORPORATION**

Address of Applicant
:14-10, Nihonbashi
Kayabacho 1-chome,
Chuo-ku, Tokyo
1038210, Japan, Japan

(72)Name of Inventor :
**1)OONISHI, Reiko
2)URAYAMA,
Yusuke**

(57) Abstract :

No. of Pages : 50 No. of Claims : 38

(12) PATENT APPLICATION PUBLICATION

(21) Application No.201917049873 A

(19) INDIA

(22) Date of filing of Application :04/12/2019

(43) Publication Date : 20/12/2019

(54) Title of the invention : NON-WOVEN FABRIC

(51) International classification :D04H 1/54,A61F
13/511,D04H 1/74
(31) Priority Document No :2017-168003
(32) Priority Date :31/08/2017
(33) Name of priority country :Japan
(86) International Application No :PCT/JP2018/026731
Filing Date :17/07/2018
(87) International Publication No :WO 2019/044220
(61) Patent of Addition to Application
Number :NA
Filing Date :NA
(62) Divisional to Application Number :NA
Filing Date :NA

(71)Name of Applicant :

1)KAO CORPORATION

Address of Applicant :14-10, Nihonbashi Kayabacho 1-chome,
Chuo-ku, Tokyo 1038210 Japan

(72)Name of Inventor :

1)SETO, Yoshihiko

2)KINUGASA, Yoshihiko

3)TANIGUCHI, Masahiro

(57) Abstract :

A non-woven fabric 10 having a movable layer 4 comprising front and rear surfaces 10SA, 10SB. The movable layer 4 has a movable region in which one surface out of the front and rear surfaces can move at least 5 mm relative to the other surface, in a direction following said one surface.

No. of Pages : 61 No. of Claims : 30

(12) PATENT APPLICATION PUBLICATION

(21) Application No.201917049876 A

(19) INDIA

(22) Date of filing of Application :04/12/2019

(43) Publication Date : 20/12/2019

(54) Title of the invention : NONWOVEN FABRIC

(51) International classification	:D04H 1/76,D04H 1/74	(71)Name of Applicant :
(31) Priority Document No	:2017-168002	1)KAO CORPORATION
(32) Priority Date	:31/08/2017	Address of Applicant :14-10, Nihonbashi Kayabacho 1-chome, Chuo-ku, Tokyo 1038210 Japan
(33) Name of priority country	:Japan	(72)Name of Inventor :
(86) International Application No	:PCT/JP2018/026730	1)KINUGASA, Yoshihiko
Filing Date	:17/07/2018	2)SETO, Yoshihiko
(87) International Publication No	:WO 2019/044219	3)TANIGUCHI, Masahiro
(61) Patent of Addition to Application Number	:NA	
Filing Date	:NA	
(62) Divisional to Application Number	:NA	
Filing Date	:NA	

(57) Abstract :

Disposed on one side of this nonwoven fabric 10, longitudinal ridges 11 project towards said one side in the thickness direction of the nonwoven fabric, are arranged extending in one direction Y on one side in planar view and are arranged side-by-side, separated from each other in another direction X, different from the one direction Y, on the one surface in the planar view, and transverse ridges 21 extend in the other direction X on the aforementioned one side and are arranged connecting the longitudinal ridges 11. The alignment direction of the fibers constituting the longitudinal ridges 11 and the alignment direction of the fibers constituting the transverse ridges 21 are different.

No. of Pages : 63 No. of Claims : 31

(54) Title of the invention : DEVICE AND METHOD FOR COOLING STEEL MATERIAL

(51) International classification	:B21B 45/02,C21D 9/00	(71)Name of Applicant :
(31) Priority Document No	:2017-179352	1)NIPPON STEEL CORPORATION
(32) Priority Date	:19/09/2017	Address of Applicant :6-1, Marunouchi 2-chome, Chiyoda-ku, Tokyo 1008071 Japan
(33) Name of priority country	:Japan	(72)Name of Inventor :
(86) International Application No	:PCT/JP2018/034066	1)SAKAMOTO, Akihiro
Filing Date	:13/09/2018	2)YAMAGISHI, Shunsuke
(87) International Publication No	:WO 2019/059105	3)KAWAI, Masanori
(61) Patent of Addition to Application Number	:NA	
Filing Date	:NA	
(62) Divisional to Application Number	:NA	
Filing Date	:NA	

(57) Abstract :

This device for cooling a steel material after hot-finish rolling has: a transport mechanism which transports the steel material while accelerating the steel material; a water-cooling mechanism which cools the steel material transported by the transport mechanism; and a control unit which controls the transport mechanism and the water-cooling mechanism so that the steel material is cooled so as to satisfy equation (1) below, wherein the water-cooling time reduction rate in equation (1) is determined on the basis of: the length of a water-cooling zone in which the water-cooling mechanism is provided; and the time $tC(0)$ required to cool a tip portion of the steel material down to a target temperature. Equation (1): $tC(x)=tC(0)-x$, where x is the position along the steel material with respect to the tip portion of the steel material in the transport direction, and $tC(x)$ is the time required to cool the portion of the steel material at position x down to the target temperature.

No. of Pages : 32 No. of Claims : 9

(54) Title of the invention : WET DESULFURIZATION WASTEWATER RESOURCE PROCESSING SYSTEM AND PROCESSING METHOD THEREFOR

(51) International classification	:C02F 9/10
(31) Priority Document No	:201710379789.X
(32) Priority Date	:25/05/2017
(33) Name of priority country	:China
(86) International Application No	:PCT/CN2017/102654
Filing Date	:21/09/2017
(87) International Publication No	:WO/2018/214350
(61) Patent of Addition to Application Number	:NA
Filing Date	:NA
(62) Divisional to Application Number	:NA
Filing Date	:NA

(71)Name of Applicant :

1)BEIJING GUODIAN LONGYUAN ENVIRONMENTAL ENGINEERING CO., LTD

Address of Applicant :9F, Building 1, Yard 16, W. 4th Ring Rd, Haidian Dist Beijing 100039 China

(72)Name of Inventor :

1)TANG, Jian

2)CHEN, ZhenYu

3)CHEN, Ou

4)ZHONG, HongLing

5)LAO, Jun

6)YAO, Xuan

7)PENG, GuangJun

8)CHU, Yue

(57) Abstract :

A system for resource generating treatment of waste water by wet desulphurization and a treating method thereof. The system includes a waste-water-to-be-desulphurized pre-treating system, a first-stage quality regulating system, a deep modulating system and a calcium-chloride-solid generating system that are successively connected. The waste-water-to-be-desulphurized pre-treating system includes a concentrating tower and a pre-desulphurization flue and a waste-water-to-be-desulphurized storage tank that are connected to the concentrating tower. The first-stage quality regulating system includes a slurry discharge pump, a first-stage quality regulating tank and a first solid-liquid separation device that are connected successively in the stream direction. The deep modulating system includes a deep modulating tank, a clarifiocccuation pool and a second solid-liquid separation device that are connected successively in the stream direction. The deep modulating tank is connected to the first solid-liquid separation device and a second agent adding device. The clarifiocccuation pool and the second solid-liquid separation device are connected to a second collecting vessel. The calcium-chloride-solid generating system includes a dryer, a drying air fan and a third collecting vessel. The present disclosure is safe and easy to operate, has a good value for promotion and practicing, and will generate a good economic benefit after extensive promotion and application.

No. of Pages : 12 No. of Claims : 9

(12) PATENT APPLICATION PUBLICATION

(21) Application No.201917050638 A

(19) INDIA

(22) Date of filing of Application :08/12/2019

(43) Publication Date : 20/12/2019

(54) Title of the invention : AN OPTICAL WIRELESS COMMUNICATION SYSTEM AND ADAPTIVE OPTICAL WIRELESS COMMUNICATION NETWORK

(51) International classification :H04B 10/114
(31) Priority Document No :1709229.7
(32) Priority Date :09/06/2017
(33) Name of priority country :U.K.
(86) International Application No :PCT/EP2018/064947
Filing Date :07/06/2018
(87) International Publication No :WO/2018/224575
(61) Patent of Addition to Application Number :NA
Filing Date :NA
(62) Divisional to Application Number :NA
Filing Date :NA

(71)**Name of Applicant :**
1)VELMENNI OU
Address of Applicant :181A RIIA 51014 Tartu Estonia
(72)**Name of Inventor :**
1)SOLANKI, Deepak

(57) Abstract :

A communication system is provided, comprising a plurality of network members, each one comprising at least one first communication interface adapted to communicatively couple to any other one of the of said plurality of network members and a user device via optical wireless communication (OWC); at least one gateway member, comprising at least one second communication interface adapted to communicatively couple to any one of said plurality of network members via optical wireless communication (OWC), said at least one second communication interface is further adapted to communicatively couple to at least one external communication network; at least one portable access member, removably connectable to a user device and comprising at least one third communication interface adapted to communicatively couple said user device to any one of said plurality of network members via optical wireless communication (OWC), and wherein said communication system is adapted to form any one of a duplex ring network topology and a duplex mesh network topology, utilising said plurality of network members and said at least one gateway member.

No. of Pages : 12 No. of Claims : 13

(12) PATENT APPLICATION PUBLICATION

(21) Application No.201917051420 A

(19) INDIA

(22) Date of filing of Application :12/12/2019

(43) Publication Date : 20/12/2019

(54) Title of the invention : NONWOVEN FABRIC

(51) International classification :D04H 1/76,A61F
13/511,D04H 1/74
(31) Priority Document No :2017-168000
(32) Priority Date :31/08/2017
(33) Name of priority country :Japan
(86) International Application No :PCT/JP2018/026729
Filing Date :17/07/2018
(87) International Publication No :WO 2019/044218
(61) Patent of Addition to Application
Number :NA
Filing Date :NA
(62) Divisional to Application Number :NA
Filing Date :NA

(71)Name of Applicant :

1)KAO CORPORATION

Address of Applicant :14-10, Nihonbashi Kayabacho 1-chome,
Chuo-ku, Tokyo 1038210 Japan

(72)Name of Inventor :

1)KINUGASA, Yoshihiko

2)ITO, Hyuma

3)TANIGUCHI, Masahiro

4)SETO, Yoshihiko

5)TOMBE, Keiichiro

(57) Abstract :

This nonwoven fabric (10), which has a first side (Z1) and a second side (Z2) and comprises thermoplastic fibers, has outside fiber layers (1), (2) on the first side (Z1) and the second side (Z2) in which fibers are oriented in the planar direction, and multiple linking parts (3) which are arranged between the outside fiber layer 1 on the first side (Z1) and the outside fiber layer (2) on the second side (Z2) and which comprises fibers oriented in the thickness direction of the nonwoven fabric. A portion of fibers of the outside fiber layer (1) on the first side (Z1) and the outside fiber layer (2) on the second side (Z2) and a portion of the fibers of the linking units (3) are fused to each other.

No. of Pages : 66 No. of Claims : 38

(12) PATENT APPLICATION PUBLICATION

(21) Application
No.201821023690 A

(19) INDIA

(22) Date of filing of Application :26/09/2018

(43) Publication Date :
20/12/2019

(54) Title of the invention : AN AGRICULTURAL VEHICLE

(51)
International :A01B0051020000,A01C0023000000,A01C0015000000,B60G0009020000,B62D0061060000
classification
(31) Priority
Document :NA
No
(32) Priority :NA
Date
(33) Name
of priority :NA
country
(86)
International
Application :NA
No :NA
Filing
Date
(87)
International
Publication : NA
No
(61) Patent
of Addition
to
Application :NA
Number :NA
Filing
Date
(62)
Divisional to
Application :NA
Number :NA
Filing
Date

(71)**Name of Applicant**
:
**1)INDUSTILL
FARMTECH
PRIVATE LIMITED**
Address of
Applicant :Flat No.
2105, BLDG A,
Asawari, Nanded City,
Pune-410041,
Maharashtra, India.
Maharashtra India
(72)**Name of Inventor :**
**1)Mande Shrilesh
Rajendra
2)Borhade Ajinkya
Rajan
3)Mutake Nikhil
Manohar
4)Mande Jitendra
Ramdas**

(57) Abstract :

ABSTRACT AN AGRICULTURAL VEHICLE An agricultural vehicle is disclosed herein. The agricultural vehicle comprises a chassis having a bent configuration defined by a bent portion configured between a pair of substantially horizontal support portions; a first pair of wheels supported at an operative front section of the chassis; a second pair of wheels supported at an operative rear section of the chassis; at least one mounting link pivotally connected to the bent portion of the chassis, wherein one end of the at least one mounting link is pivotally connected to a support member configured on the bent portion of the chassis; an agricultural tool coupled to another end of the at least one mounting link; a displacement mechanism coupled to the agricultural tool for facilitating the displacement of the agricultural tool in an operatively vertical direction; a seating arrangement configured on the chassis substantially above the second pair of wheels; and a steering mechanism. [To be published with Fig. 1A]

No. of Pages : 21 No. of Claims : 10

(12) PATENT APPLICATION PUBLICATION

(21) Application
No.201821033330 A

(19) INDIA

(22) Date of filing of Application :05/09/2018

(43) Publication Date :
20/12/2019

(54) Title of the invention : A LEAK-PROOF PORTABLE FOOD AND BEVERAGE STORAGE CONTAINER

(51)
International :B65D0043020000,A45C0011200000,B65D0025100000,F25D0003080000,B65D0043160000
classification
(31) Priority
Document :NA
No
(32) Priority :NA
Date
(33) Name
of priority :NA
country
(86)
International
Application :NA
No :NA
Filing
Date
(87)
International
Publication : NA
No
(61) Patent
of Addition
to
Application :NA
Number :NA
Filing
Date
(62)
Divisional to
Application :NA
Number :NA
Filing
Date

(71)**Name of Applicant**
:
1)Vikram M. Nahar
Address of Applicant
:144/B, Chimli Phata,
Village Kuruli, Taluka
Khed, Near Chakan,
Pune, India (IN)
Maharashtra India
(72)**Name of Inventor** :
1)Vikram M. Nahar

(57) Abstract :

ABSTRACT A LEAK-PROOF PORTABLE FOOD AND BEVERAGE STORAGE CONTAINER The present invention provides a leak-proof portable food and beverage storage container (1000) comprising a box body (200) defining a storage cavity, a lid (400), a ring (600), and a locking mechanism (800). The lid (400) has a groove (410) arranged along edges (420) of the lid (400) and the ring (600) is disposed within the groove (410). The locking mechanism (800) is operationally coupled to the box body (200) and includes a plurality of flaps (810) and a band (820). The plurality of flaps (810) are hingedly connected to the edges (420) and the band (820) is arranged around a rim of the box body (200). Further, the plurality of flaps (810) snap-fits with the band (820) such that the lid (400) is securely fixed to the box body (200) and the ring (600) creates an air-tight seal between the lid (400) and the box body (200). FIG. 1

No. of Pages : 25 No. of Claims : 10

(12) PATENT APPLICATION PUBLICATION

(21) Application
No.201821046439 A

(19) INDIA

(22) Date of filing of Application :07/12/2018

(43) Publication Date :
20/12/2019

(54) Title of the invention : ROLLING SYSTEM FOR ROLLING OF FLAT BAR FOR COAMINGS

(51)
International :B21B0013120000,B21D0005140000,B65G0039200000,B01F0003180000,B21B0013080000
classification
(31) Priority
Document :NA
No
(32) Priority :NA
Date
(33) Name
of priority :NA
country
(86)
International
Application :NA
No :NA
Filing
Date
(87)
International
Publication : NA
No
(61) Patent
of Addition
to
Application :NA
Number :NA
Filing
Date
(62)
Divisional to
Application :NA
Number :NA
Filing
Date

(71)**Name of Applicant :**
**1)Mazagon Dock
Shipbuilders Limited**
Address of Applicant
:Dockyard Road,
Mazagon, Mumbai -
400010, Maharashtra,
India Maharashtra India
(72)**Name of Inventor :**
**1)THAKKAR,
Gaurav**
2)SARANG, Sandeep
S

(57) Abstract :

The present subject matter discloses a rolling system for rolling of flat bar for coaming. The rolling system 100 comprises at least two bottom rollers 304 arranged in a horizontal line, a top roller 302 arranged above the at least two bottom rollers 304, at least one motor 104 to drive a gear box, wherein the gear box provides rotational motion to at least two bottom rollers 304, a slant bar 118, at least one vertical linkage 106 attached with at least one a horizontal linkage 108 are rigidly connected to form an angled linkage; said angled linkage is pivotally connected to said slant bar 118 at pivot joint 114. The rolling system 100 comprises at least one hydraulic jack 110 to oscillate said angled linkage against the pivotal joint 114 to facilitate upward and downward motion to the top roller 302 and at least one vertical base platform 120.

No. of Pages : 18 No. of Claims : 13

(12) PATENT APPLICATION PUBLICATION

(21) Application
No.201821047479 A

(19) INDIA

(22) Date of filing of Application :14/12/2018

(43) Publication Date
: 20/12/2019

(54) Title of the invention : HYDROGEN FUEL CELL STACK

(51)
International :H01M0008025800,H01M0008241000,H01M0008026700,H01M0008245700,H01M0008022800
classification
(31) Priority
Document :NA
No
(32) Priority :NA
Date
(33) Name
of priority :NA
country
(86)
International
Application :NA
No :NA
Filing
Date
(87)
International
Publication : NA
No
(61) Patent
of Addition
to
Application :NA
Number :NA
Filing
Date
(62)
Divisional to
Application :NA
Number :NA
Filing
Date

(71)**Name of Applicant :**
1)KPIT TECHNOLOGIES LTD
Address of Applicant :Plot No: 45, Rajiv Gandhi Infotech Park, Phase 1, MIDC, Hinjewadi, Pune Maharashtra-411057, India. Maharashtra India
(72)**Name of Inventor :**
1)LICHADE, Pankaj Kumar

(57) Abstract :

The present invention discloses a hydrogen fuel cell stack (100) which comprises one or more hydrogen fuel cells with an anode cathode partition plate between each adjacent hydrogen fuel cells. Each hydrogen fuel cell comprises an anode bipolar plate (102), a cathode bipolar plate (106) and an MEA (108). The anode bipolar plate (102) with a first flow field (112) provides a path for hydrogen to pass underneath the anode bipolar plate (102). The cathode bipolar plate (106) with a second flow field of an array of dome shaped springs (114) with an eccentric hole (116) on top of every spring converts laminar flow (402) of air to turbulence flow (404) to effectively utilize the air. The MEA is positioned between the anode bipolar plate and the cathode bipolar plate. The hydrogen fuel cell stack further manages heat, pressure and water to achieve effective chemical reaction and generate electric current.

No. of Pages : 27 No. of Claims : 14

(12) PATENT APPLICATION PUBLICATION

(21) Application
No.201821047632 A

(19) INDIA

(22) Date of filing of Application :17/12/2018

(43) Publication Date :
20/12/2019

(54) Title of the invention : ENERGY EFFICIENT FUEL BURNING APPARATUS OR GAS STOVE.

(51)
International :H01M0010440000,G11B0017049000,G03G0015080000,A24D0003060000,B65D000622000
classification 0

(31) Priority
Document :NA
No

(32) Priority :NA
Date

(33) Name
of priority :NA
country

(86)
International
Application :NA
No :NA

Filing
Date

(87)
International :NA
Publication
No

(61) Patent
of Addition
to
Application :NA
Number :NA

Filing
Date

(62)
Divisional to
Application :NA
Number :NA

Filing
Date

(57) Abstract :
NA

No. of Pages : 12 No. of Claims : 12

(71)Name of Applicant
:

**1)NISHA N
VADALIA**
Address of
Applicant :801
PRABHAT COMPLEX
1, GOVERNMENT
PRESS ROAD,
RAJKOT 360 001,
GUJARAT,INDIA.
Gujarat India

(72)Name of Inventor :

**1)NISHA N
VADALIA**
**2)NAVINCHANDR
A VADALIA**

(12) PATENT APPLICATION PUBLICATION

(21) Application
No.201921001364 A

(19) INDIA

(22) Date of filing of Application :11/01/2019

(43) Publication Date :
20/12/2019

(54) Title of the invention : MANUFACTURING OF DOOR FRAMES BY PVC RESINS AND PVC SCRAP

(51)
International :C08K0005000000,G03G0009087000,C08K0005098000,E04F0015100000,C08J0011060000
classification
(31) Priority
Document :NA
No
(32) Priority :NA
Date
(33) Name
of priority :NA
country
(86)
International
Application :NA
No :NA
Filing
Date
(87)
International : NA
Publication
No
(61) Patent
of Addition
to
Application :NA
Number :NA
Filing
Date
(62)
Divisional to
Application :NA
Number :NA
Filing
Date

(71)Name of Applicant :
**1)Vivek Khetabhai
Patel**
Address of Applicant
:Hi Tech Industries
having address plot no 67
& 68, Sector F, Phase I,
Parwati Co-op Ind.
Estate, Ltd, Yadrav, Tal:
Shirol, Dist: Kolhapur,
Pin code 416145,
Maharashtra, India
Maharashtra India
**2)Dr. Suryakant
Babanrao Patil**
(72)Name of Inventor :
**1)Vivek Khetabhai
Patel**
**2)Dr. Suryakant
Babanrao Patil**

(57) Abstract :

The present disclosure provides processes and compositions for manufacturing door frames using poly vinyl chloride (PVC). The present disclosure provides processes for manufacturing doors using PVC resins or PVC recycled scrap. It is because of the fact that PVC is cheaper, lighter in weight, high durability, flexible in nature, high versatility. These door frames can be made by the waste products of PVC. Waste material can be resins, recycled scrap, and old PVC materials.

No. of Pages : 15 No. of Claims : 8

(12) PATENT APPLICATION PUBLICATION

(21) Application
No.201921002068 A

(19) INDIA

(22) Date of filing of Application :17/01/2019

(43) Publication Date :
20/12/2019

(54) Title of the invention : INDUSTRIAL THERMAL INSULATION BLANKETS

(51)
International :B64C0001400000,B32B0003080000,E04B0001780000,H05B0003340000,B32B0005260000
classification
(31) Priority
Document :NA
No
(32) Priority :NA
Date
(33) Name
of priority :NA
country
(86)
International
Application :NA
No :NA
Filing
Date
(87)
International : NA
Publication
No
(61) Patent
of Addition
to
Application :NA
Number :NA
Filing
Date
(62)
Divisional to
Application :NA
Number :NA
Filing
Date

(71)**Name of Applicant :**
**1)Prem Kumar
Sharma**
Address of Applicant
:Managing Director,
Renuka Auto
Components (I) Pvt Ltd.,
D-1 block, Plot no.
20/1,Chinchwad,Pune
411019. Maharashtra
India
(72)**Name of Inventor :**
**1)Prem Kumar
Sharma**

(57) Abstract :

The present invention provides thermal insulation blanket for reducing the heat ingress into the interior of the vehicle cabin. The thermal insulation blanket includes a first layer of an Aluminium coated high heated E Glass fabric; a second layer of an E glass needle punched fiber; and a third layer of an E glass heat treated fabric; wherein said blanket includes PTFE Coated glass thread for stitching the first layer, second layer and third layer, and wherein said second layer is sandwiched between the first layer and second layer respectively.

No. of Pages : 22 No. of Claims : 10

(12) PATENT APPLICATION PUBLICATION

(21) Application
No.201921003294 A

(19) INDIA

(22) Date of filing of Application :26/01/2019

(43) Publication Date :
20/12/2019

(54) Title of the invention : ENDODONTIC ACCESS ISOLATORS

(51)
International :A61C0005400000,A61K0006000000,A61C0005500000,C12Q0001688600,H04L0001180000
classification

(31) Priority
Document :NA
No

(32) Priority
Date :NA

(33) Name
of priority :NA
country

(86)
International
Application :NA
No :NA

Filing
Date

(87)
International
Publication : NA
No

(61) Patent
of Addition
to
Application :NA
Number :NA

Filing
Date

(62)
Divisional to
Application :NA
Number :NA

Filing
Date

(71)Name of Applicant
:

**1)Dr RAJDEEP
PAVASKAR**
Address of
Applicant :B7, Hill
View Cooperative
Housing Society, Opp
Govt Bungalow E6,
Near ITI, Altinho, Panaji
Goa India

(72)Name of Inventor :

**1)Dr RAJDEEP
PAVASKAR**
2)Dr. Kaveri Gandhi

(57) Abstract :

ABSTRACT ENDODONTIC ACCESS ISOLATORS Endodontic access isolators (EAI) are single use collapsible disposable or autoclavable rubber or plastic inserts with a flat occlusal platform on one side and a hollow cylindrical projection which serves as an instrumentation tunnel on the other side, separated by a groove. EAI are used in prosthetically restored teeth or grossly mutilated teeth with tissue growth which need endodontic treatment or retreatment due to various reasons. EAI enables use of apex locators in root canals that are carried out via access openings through the metal or metal ceramic restorations or crowns, wherein working length determination with apex locators isn't reliable. Patients benefit by reduced x-ray exposure and lowered costs.

No. of Pages : 5 No. of Claims : 5

(12) PATENT APPLICATION PUBLICATION

(21) Application
No.201921006217 A

(19) INDIA

(22) Date of filing of Application :17/02/2019

(43) Publication Date :
20/12/2019

(54) Title of the invention : HOSPITAL AND PATIENT CARE MANAGEMENT SYSTEM

(51)
International :G16H0050200000,A61B0005021000,G16H0040200000,A61G0012000000,F16M0013020000
classification

(31) Priority
Document :NA
No

(32) Priority :NA
Date

(33) Name
of priority :NA
country

(86)
International
Application :NA
No :NA

Filing
Date

(87)
International : NA
Publication
No

(61) Patent
of Addition
to
Application :NA
Number :NA

Filing
Date

(62)
Divisional to
Application :NA
Number :NA

Filing
Date

(71)Name of Applicant

:
**1)Prof. Jitendra
Prakash Patil**
Address of
Applicant :R C Patel
Institute of Technology
,Shirpur 425405
Maharashtra India

**2)Dr. Tushar
Hrshikesh Jaware**
**3)Dr. Hemprasad
Yashwant Patil**
**4)Prof. Ravindra
Daga Badgujar**

**5)Prof. Vinod kumar
Ramesh Patil**
**6)Dr. Dipak
Pandurang Patil**

**7)Dr. Suryakant
Babanrao Patil**

(72)Name of Inventor :

**1)Prof. Jitendra
Prakash Patil**
**2)Dr. Tushar
Hrshikesh Jaware**
**3)Dr. Hemprasad
Yashwant Patil**

**4)Prof. Ravindra
Daga Badgujar**
**5)Prof. Vinod kumar
Ramesh Patil**

**6)Dr. Dipak
Pandurang Patil**
**7)Dr. Suryakant
Babanrao Patil**

(57) Abstract :

The present disclosure relates generally to the healthcare industry and in particular relates to a hospital patient care and also relates to method and system of hospital management. A method and system for assisting patient care is provided. The method includes the steps of: receiving details of pre-existing diseases of a patient; calibrating one or more patient care equipment based on pre-existing diseases; monitoring health related parameters of said patient; determining if values corresponding to said health related parameters are within pre-defined threshold values; transmitting details to an electronic device held by a doctor assigned to said patient if values corresponding to said health related parameters are beyond pre-defined threshold values; and receiving a calibrating signal from the electronic device of the doctor to calibrate said one or more patient care equipment based on determined values corresponding to health related parameters.

No. of Pages : 24 No. of Claims : 7

(12) PATENT APPLICATION PUBLICATION

(21) Application
No.201921007692 A

(19) INDIA

(22) Date of filing of Application :27/02/2019

(43) Publication Date :
20/12/2019

(54) Title of the invention : A MODULAR ALL IN ONE CARTRIDGE FOR TESTING ELECTROLYTES IN A SAMPLE OF BODY FLUID

(51)
International :G01N0027333000,G01N0033040000,G01N0021800000,G01N0033120000,G01N0019000000
classification 0

(31) Priority
Document :NA
No

(32) Priority :NA
Date

(33) Name
of priority :NA
country

(86)
International
Application :NA
No :NA

Filing
Date

(87)
International
Publication : NA
No

(61) Patent
of Addition
to
Application :NA
Number :NA

Filing
Date

(62)
Divisional to
Application :NA
Number :NA

Filing
Date

(71)Name of Applicant
:
**1)DiaSys Diagnostics
India Pvt. Ltd.**

Address of Applicant
:Plot# A821, TTC -
Mahape MIDC Navi
Mumbai 400710,
Maharashtra, India.
Maharashtra India

(72)Name of Inventor :
**1)MATHUR,
Vijaywanth
2)MAMDAPURKAR
, Ramesh
3)SANE, Nikhil
4)SAINI, Amardeep
Singh
5)GORKA, Guenther**

(57) Abstract :

A device for testing one or more electrolytes and other parameters in a sample of body fluids is disclosed that is based on a disposable, modular and all in one cartridge. The modular cartridge 200 includes a sensor module 300 having sensors including one or more sensors sensitive to the electrolytes to be tested, and working based on ion-selective electrode technology; a set of bags 204 to store one or more reference reagents and waste. The cartridge 200 is inserted in an analyser on which it mechanically couples with the analyser. A silicone valve selectively couples a probe 210 to the bags 204 storing reference reagents and a sample port of the analyser. A RFID label is provided to store data related to the cartridge, and is wirelessly readable and editable by a RFID reader in the analyser.

No. of Pages : 21 No. of Claims : 15

(12) PATENT APPLICATION PUBLICATION

(21) Application
No.201921008242 A

(19) INDIA

(22) Date of filing of Application :02/03/2019

(43) Publication Date :
20/12/2019

(54) Title of the invention : AUTOMATIC TUBE LABELING SYSTEM AND METHOD THEREOF

(51)
International :B65C0009180000,G01N0035000000,G01N0035040000,A61F0005441000,G09F0003020000
classification
(31) Priority
Document :NA
No
(32) Priority :NA
Date
(33) Name
of priority :NA
country
(86)
International
Application :NA
No :NA
Filing
Date
(87)
International : NA
Publication
No
(61) Patent
of Addition
to
Application :NA
Number :NA
Filing
Date
(62)
Divisional to
Application :NA
Number :NA
Filing
Date

(71)**Name of Applicant**
:
**1)AGAPPE
DIAGNOSTICS
LIMITED**
Address of Applicant
:Office No. 401 & 402,
4th Floor, Jaisingh
Business Centre, 119,
Sahar Road, Parsiwada,
Andheri (East), Mumbai.
Maharashtra India
(72)**Name of Inventor** :
**1)THOMAS JOHN
2)VARGHESE
OUSEPH
3)ANEESH K N
4)ELDHO PAUL
5)JOSEPH J
PALLIPAT**

(57) Abstract :

The invention relates to an automatic labelling system (100). Particularly the invention relates to an automatic labelling device (101) for adhering an identification label to a surface of primary and secondary tubes. The system comprises of one or more network enabled devices communicating patient or user information from the laboratory information system to the automated labelling device (101). The device comprises of a rack (1) comprising of one or more rows (1a, 1b, 1c, 1d, 1e, 1f), one or more solenoids (2a, 2b, 2c, 2d, 2e, 2f, 9, 10), a tube vent (3) leading to the tube guide (4), to a labelling chamber (5), one or more sensors (6, 7), an idler assembly (11), a collection tray (13), a drawer assembly (16) mounting a printing apparatus (12, 14) a labelling apparatus and one or more ejection ports (20, 21). Figure 7.

No. of Pages : 29 No. of Claims : 10

(12) PATENT APPLICATION PUBLICATION

(21) Application
No.201921022471 A

(19) INDIA

(22) Date of filing of Application :06/06/2019

(43) Publication Date :
20/12/2019

(54) Title of the invention :Magnetic field-assisted micro-plasma transferred arc powder additive layer manufacturing process€ •

(51)
International :B22F0003105000,B33Y0010000000,B33Y0030000000,B23K0026342000,B33Y0080000000
classification
(31) Priority
Document :NA
No
(32) Priority :NA
Date
(33) Name
of priority :NA
country
(86)
International
Application :NA
No :NA
Filing
Date
(87)
International : NA
Publication
No
(61) Patent
of Addition
to
Application :NA
Number :NA
Filing
Date
(62)
Divisional to
Application :NA
Number :NA
Filing
Date

(71)**Name of Applicant**
:
**1)Indian Institute of
Technology Indore (IIT
Indore)**
Address of Applicant
:104, Titanium POD
Building, AMP Lab,
Indian Institute of
Technology Indore,
Simrol, Madhya Pradesh
453 552 Madhya Pradesh
India
(72)**Name of Inventor :**
**1)MAYUR
SUDHAKAR
SAWANT**
2)PANKAJ KUMAR
**3)NEELESH
KUMAR JAIN**

(57) Abstract :

ABSTRACTMagnetic field assisted micro-plasma transferred arc powder additive layer manufacturing process€ • Accordingly embodiments herein disclose a magnetic field assisted micro-plasma transferred arc powder additive layer manufacturing (MFA-μ-PTAPALM) process (100) includes generating a pilot arc between a negatively charged electrode and a positively charged nozzle, forming a micro-plasma arc between the positively charged nozzle and a substrate (170) by ionizing the pilot arc with an inert gas, applying the magnetic field below the micro-plasma arc at a top surface of the substrate (170), forming a melt pool on a surface of the substrate (170) by passing the micro-plasma arc through constricted nozzle towards the substrate (170), and creating a deposition layer on the substrate (170) by feeding powder into the melt pool. FIG. 1

No. of Pages : 6 No. of Claims : 14

(12) PATENT APPLICATION PUBLICATION

(21) Application No.201921023086 A

(19) INDIA

(22) Date of filing of Application :11/06/2019

(43) Publication Date : 20/12/2019

(54) Title of the invention : SYSTEMS AND METHODS FOR AUTOMATIC MEDICINE VENDING MACHINE

(51) International classification

:H04L51/36

(31) Priority Document No

:NA

(32) Priority Date

:NA

(33) Name of priority country

:NA

(86) International Application No

:NA

Filing Date

:NA

(87) International Publication No

: NA

(61) Patent of Addition to Application Number

:NA

Filing Date

:NA

(62) Divisional to Application Number

:NA

Filing Date

:NA

(71)Name of Applicant :

1)SHAH PAYAL

Address of Applicant :SARDAR PATEL INSTITUTE OF TECHNOLOGY, MUNSHI NAGAR, BHAVAN'S CAMPUS, ANDHERI (W), MUMBAI-400058, MAHARASHTRA, INDIA. Maharashtra India

2)SUTAR RAJENDRA

(72)Name of Inventor :

1)BANDIWADEKAR VARSHADA

2)SHAIKH SHAKILA

3)SHINDE SHROTI

4)SHAH PAYAL

5)SUTAR RAJENDRA

(57) Abstract :

ABSTRACT SYSTEMS AND METHODS TO AUTOMATIC MEDICINE VENDING MACHINE An automatic medicine vending machine design includes a currency acceptor unit,dispenser unit,display mechanism, wireless module,controller unit. The currency acceptor unit has sensor mechanism for detection of the inserted currency.Dispenser unit will dispense the medicine according to the user requirement.Display mechanism is used to give the information regarding steps to be followed while accessing the device.Wireless module is used for communication between controller and android application.This entire system includes the software which is programmed such as when the patient clicks/selects a particular option the patient will be served with that required option or service. The application comprises features such as ambulance facility,medicine facility, doctor calling facility and hospital location availability.

No. of Pages : 12 No. of Claims : 6

(12) PATENT APPLICATION PUBLICATION

(21) Application
No.201921037522 A

(19) INDIA

(22) Date of filing of Application :18/09/2019

(43) Publication Date :
20/12/2019

(54) Title of the invention : SUGARCANE PLANTER

(51)
International :A01G0009020000,A01C0005060000,A01C0007200000,A01C0011000000,B65G0067120000
classification

(31) Priority
Document :NA
No

(32) Priority
Date :NA

(33) Name
of priority :NA
country

(86)
International
Application :NA
No :NA

Filing
Date

(87)
International
Publication : NA
No

(61) Patent
of Addition
to
Application :NA
Number :NA

Filing
Date

(62)
Divisional to
Application :NA
Number :NA

Filing
Date

(71)Name of Applicant
:

**1)ATUL G
BHONGALE**
Address of
Applicant :A/P
SHETPHAL, HAVELI,
INDAPUR - 413103,
MAHARASHTRA,
INDIA Maharashtra
India

**2)SHRIDHAR
TAMBADE**
3)AJIT R PATIL
**4)PRAMOD G.
RAHATE**

(72)Name of Inventor :

**1)ATUL G
BHONGALE**
**2)SHRIDHAR
TAMBADE**
3)AJIT R PATIL
**4)PRAMOD G.
RAHATE**

(57) Abstract :

No. of Pages : 12 No. of Claims : 4

(54) Title of the invention : A NANO PARTICLE BASED COMPOSITION FOR ENHANCING THE PERFORMANCE AND EMISSION OF DIESEL ENGINE AND A PROCESS THEREOF

(51) International :C11C0003000000,C10L0001020000,C10M0177000000,F02B0003060000,C07C0067580000 classification
 (31) Priority Document :NA
 No
 (32) Priority Date :NA
 (33) Name of priority :NA
 country
 (86) International Application :NA
 No :NA
 Filing Date
 (87) International Publication :NA
 No
 (61) Patent of Addition to Application :NA
 Number :NA
 Filing Date
 (62) Divisional to Application :NA
 Number :NA
 Filing Date

(71)Name of Applicant :
1)Patil Darshan Prashant
 Address of Applicant :JSPMs Narhe Technical Campus,Narhe Pune-MH-INDIA Maharashtra India
2)Bajare Ganesh Tukaram
3)Kamble Diksha Jandao
4)Shah Yash Amol
5)Supriya Bobade
6)Bagul Vilas Padurang
7)G.Senthilkumar
8)Birajdar Suraj Suresh
9)Gondhale Upendra NISHCHAL
10)Pradeep Uttam Gaikwad
 (72)Name of Inventor :
1)Kamble Diksha Jandao
2)Supriya Bobade
3)Gondhale Upendra NISHCHAL
4)Shah Yash Amol
5)Bajare Ganesh Tukaram
6)Birajdar Suraj Suresh
7)Bagul Vilas Padurang
8)Patil Darshan Prashant
9)Pradeep Uttam Gaikwad
10)G.Senthilkumar

(57) Abstract :

The present invention provides is a biodiesel blend composition for enhancing performance and emission parameters of diesel engine and a process for their preparation thereof using nanoparticles such as AL₂O₃ and CNT. In an initial stage, free fatty acid content in oil are reduced by esterification with methanol and acid catalyst such as sulphuric acid at a temperature in the range of 55- 570c in a closed reactor vessel. The separated oil is to be produced for transesterification Wherein Meth oxide (methanol + sodium hydroxide) is added with the fatty ester obtained in earlier step and heated at a temperature in the range of 30-650c for a period of 0.5 to 2 hours, with continuous stirring followed by natural cooling for a period of 8 hours to obtain the biodiesel that is further purified by water wash and air bubble wash. FIG. 1 (for publication)

No. of Pages : 24 No. of Claims : 9

(12) PATENT APPLICATION PUBLICATION

(21) Application
No.201921039177 A

(19) INDIA

(22) Date of filing of Application :27/09/2019

(43) Publication Date :
20/12/2019

(54) Title of the invention : SORBITAN MONORICINOLEATE AND SYNTHESIS THEREOF

(51)
International :A61K0008490000,C09K0003320000,C01B0039480000,C01B0039120000,C07D0451040000
classification
(31) Priority
Document :NA
No
(32) Priority :NA
Date
(33) Name
of priority :NA
country
(86)
International
Application :NA
No :NA
Filing
Date
(87)
International
Publication : NA
No
(61) Patent
of Addition
to
Application :NA
Number :NA
Filing
Date
(62)
Divisional to
Application :NA
Number :NA
Filing
Date

(71)**Name of Applicant**
:
1)Dr. Pratap Amit P
Address of Applicant
:F-305, 2nd Floor,
Department of Oils,
Oleochemicals and
Surfactant Technology,
Institute of Chemical
Technology, Nathalal
Parekh Marg, Matunga
(East), Mumbai-400019,
Maharashtra, India
Maharashtra India
(72)**Name of Inventor :**
1)Dr. Pratap Amit P.
2)Bhimani Rutu Fenil

(57) Abstract :

ABSTRACT SORBITAN MONORICINOLEATE AND SYNTHESIS THEREOF The present invention relates to a sorbitan fatty acid ester, especially sorbitan monoricinoleate of formula (I), to the manufacture of sorbitan monoricinoleate, to the use of sorbitan monoricinoleate as a surfactant.

No. of Pages : 48 No. of Claims : 10

(12) PATENT APPLICATION PUBLICATION

(21) Application
No.201921041393 A

(19) INDIA

(22) Date of filing of Application :12/10/2019

(43) Publication Date :
20/12/2019

(54) Title of the invention : AN ADVANCED SECURED CAR KEY

(51)
International :G07C0009000000,B60R0025000000,B60R0025250000,F02N0011080000,B60R0025040000
classification
(31) Priority
Document :NA
No
(32) Priority :NA
Date
(33) Name
of priority :NA
country
(86)
International
Application :NA
No :NA
Filing
Date
(87)
International
Publication : NA
No
(61) Patent
of Addition
to
Application :NA
Number :NA
Filing
Date
(62)
Divisional to
Application :NA
Number :NA
Filing
Date

(71)**Name of Applicant :**
**1)Saurabh Umakant
Nandane**
Address of Applicant
:Smruti, Khadka Road,
Patil Narsari, Bhusawal,
Jalgoan 425201
Maharashtra India
(72)**Name of Inventor :**
**1)Saurabh Umakant
Nandane**

(57) Abstract :

The key which has in-build fingerprint and iris scanner along with the automatic door, gear and pedal lock. The fingerprint and iris scanner will be taken with the help of the software. When the user will place the finger or iris in front of the scanner, it will match with the samples and give a positive signal to the receiver. The receiver will receive the signal and will give another signal to the doors, pedal and gear lock. With the positive signal, the receiver will open the locks. The person won't be able to start the engine, and the engine starts only after completion of the Circuit of Battery Ignition System (BIS). Hence, the engine will start with the key. SPECIFICATIONS OF THE KEY : - AN ADVANCED SECURED CAR KEY contains fingerprint and iris scanner with one operating touch screen. - BIS Circuit which will work on the key 5 - Internal Gear Lock - Internal Pedal lock - Door locks which will be operated by the key. The key is invented keeping in mind technological development and requirement of enhancing the security of the asset i.e. Car

No. of Pages : 14 No. of Claims : 1

(12) PATENT APPLICATION PUBLICATION

(21) Application
No.201921041655 A

(19) INDIA

(22) Date of filing of Application :15/10/2019

(43) Publication Date :
20/12/2019

(54) Title of the invention : AN IMPROVED SCRUB FOR SKIN TREATMENT

(51)
International :A61B0018200000,G06F0011100000,A61B0018000000,A61Q0019100000,A61Q0019000000
classification
(31) Priority
Document :NA
No
(32) Priority :NA
Date
(33) Name
of priority :NA
country
(86)
International
Application :NA
No :NA
Filing
Date
(87)
International
Publication : NA
No
(61) Patent
of Addition
to
Application :NA
Number :NA
Filing
Date
(62)
Divisional to
Application :NA
Number :NA
Filing
Date

(71)**Name of Applicant**
:
**1)HORMAZD M.
MEHTA**
Address of
Applicant :BLDG.
NO.24, GROUND
FLOOR,
ZOROASTRIAN
COLONY, TARDEO,
MUMBAI-400 007,
MAHARASHTRA,
INDIA. Maharashtra
India
(72)**Name of Inventor :**
**1)HORMAZD M.
MEHTA**

(57) Abstract :

Abstract In one of the aspect of the invention it is provided with the scrub obtained from Luffa which is a genus of tropical and subtropical vines in the cucumber family (Cucurbitaceae), the xylems provides network of the plant veins as soft material for the scrubbing for the skin care, the scrub is infused with an essential oils or soap for skin cleaning purpose, further the use of the scrubb is restricted to single use,

No. of Pages : 10 No. of Claims : 6

(12) PATENT APPLICATION PUBLICATION

(21) Application
No.201921047841 A

(19) INDIA

(22) Date of filing of Application :22/11/2019

(43) Publication Date :
20/12/2019

(54) Title of the invention : A SYSTEM AND METHOD FOR ANALYSIS OF SMART METER DATA

(51)
International :H02J0003140000,G06Q0050060000,G01D0004000000,G01R0021133000,G01R0022060000
classification
(31) Priority
Document :NA
No
(32) Priority :NA
Date
(33) Name
of priority :NA
country
(86)
International
Application :NA
No :NA
Filing
Date
(87)
International : NA
Publication
No
(61) Patent
of Addition
to
Application :NA
Number :NA
Filing
Date
(62)
Divisional to
Application :NA
Number :NA
Filing
Date

(71)Name of Applicant
:
**1)Symbiosis
International (Deemed
University)**
Address of Applicant
:Gram: Lavale, Taluka
Mulshi, District Pune,
Maharashtra, India Pin:
412115 Maharashtra
India
(72)Name of Inventor :
**1)Ms. Archana
Atmaram Chaudhari
2)Dr. Preeti Milind
Mulay**

(57) Abstract :

The present invention discloses a method for improving energy management, enabling reduced energy consumption and load shedding based on analysis of smart electricity meter data. The method discloses an intelligent system, wherein it precisely estimates residential electricity demand by using dynamically generated smart meter data using incremental clustering algorithm. The disclosed invention redesigns and develops a parameter-free incremental clustering algorithm for mining the hidden patterns of electricity load shedding such as season-wise, time (day/night) specific patterns. [To be published with Figure 1]

No. of Pages : 25 No. of Claims : 10

(12) PATENT APPLICATION PUBLICATION

(21) Application
No.201921048230 A

(19) INDIA

(22) Date of filing of Application :25/11/2019

(43) Publication Date :
20/12/2019

(54) Title of the invention : A CASCADE CYCLONE SEPARATOR FOR SEPARATION OF SUBMICRON BIOLOGICAL MATERIAL

(51)
International :B01D0021260000,C12N0001020000,G01N0033543000,G01N0001400000,B07B0009020000
classification
(31) Priority
Document :NA
No
(32) Priority :NA
Date
(33) Name
of priority :NA
country
(86)
International
Application :NA
No :NA
Filing
Date
(87)
International : NA
Publication
No
(61) Patent
of Addition
to
Application :NA
Number :NA
Filing
Date
(62)
Divisional to
Application :NA
Number :NA
Filing
Date

(71)Name of Applicant
:
**1)Symbiosis
International (Deemed
University)**
Address of
Applicant :Gram:
Lavale, Taluka Mulshi,
District Pune,
Maharashtra, India Pin:
412115 Maharashtra
India
(72)Name of Inventor :
**1)Dr. Sonawane
Chandrakant Ramesh
Chandra
2)Dr. Atul Kulkarni**

(57) Abstract :

The present invention relates to a cascade cyclone separator (100) for separating a biological material from a biological sample comprising a first centrifugal cyclone (101) and a second centrifugal cyclone (102) connected with a connector conduit (103) in series. The first centrifugal cyclone (101) is configured to capture and separate micron sized particles from the bottom outlet (108-1). Further, the second centrifugal cyclone (102) is configured to capture and separate nano sized particles from the bottom outlet (108-2). The collection efficiency of the cascade cyclone separator (100) facilitating separation of the biological material from the biological sample is at least 90%. (To be published with Figure 1)

No. of Pages : 31 No. of Claims : 11

(12) PATENT APPLICATION PUBLICATION

(21) Application
No.201921048817 A

(19) INDIA

(22) Date of filing of Application :28/11/2019

(43) Publication Date :
20/12/2019

(54) Title of the invention : COMPUTER IMPLEMENTED METHOD FOR CASHLESS BANKING FOR UNEDUCATED RURAL PEOPLE

(51)
International :G06Q0020100000,A47G0029120000,G06Q0040020000,H01L0023310000,C12M0001107000
classification
(31) Priority
Document :NA
No
(32) Priority :NA
Date
(33) Name
of priority :NA
country
(86)
International
Application :NA
No :NA
Filing
Date
(87)
International : NA
Publication
No
(61) Patent
of Addition
to
Application :NA
Number :NA
Filing
Date
(62)
Divisional to
Application :NA
Number :NA
Filing
Date

(71)**Name of Applicant**
:
1)Dr. Nishikant Jha
Address of
Applicant :Assistant
Professor & HOD ,
Department of
Accounting & Finance ,
Thakur College of
Science & Commerce
[Autonomus]
(University of
Mumbai), Thakur
Village, Kandivali
(East); Mumbai-
400101, Maharashtra,
India Maharashtra India
(72)**Name of Inventor**
:
1)Dr. Nishikant Jha

(57) Abstract :

The present invention is related to a computer implemented method for cashless banking for uneducated rural people. The objective of the present invention is to solve the problems of the prior arts in solving issues of cashless banking for uneducated rural people. The trends and behavior of rural people in an online banking transaction is studied and developed a computer implemented method for effective and user friendly cashless banking platform.

No. of Pages : 26 No. of Claims : 5

(12) PATENT APPLICATION PUBLICATION

(21) Application
No.201921049435 A

(19) INDIA

(22) Date of filing of Application :02/12/2019

(43) Publication Date :
20/12/2019

(54) Title of the invention : MACHINE LEARNING CLASSIFICATION TO ANALYSE PROGNOSTIC VALUE FOR CURRENT IMAGING BIOMARKER IN EYE DISEASES

(51)
International :G06K0009620000,A61B0003120000,G06K0009460000,G06N0003080000,G06K0009000000
classification
(31) Priority
Document :NA
No
(32) Priority :NA
Date
(33) Name
of priority :NA
country
(86)
International
Application :NA
No :NA
Filing
Date
(87)
International : NA
Publication
No
(61) Patent
of Addition
to
Application :NA
Number :NA
Filing
Date
(62)
Divisional to
Application :NA
Number :NA
Filing
Date

(71)**Name of Applicant**
:
1)Gauri Borkhade
Address of
Applicant :Department
of Electronics &
Telecommunication,
Ramrao Adik Institute
of Technology, Dr.
D.Y.Patil Vidyannagar,
Sector-7,Nerul,Navi
Mumbai, Maharashtra
400706, India
Maharashtra India
2)Ranjana Raut
3)Shyam Akashe
(72)**Name of Inventor :**
1)Gauri Borkhade
2)Ranjana Raut
3)Shyam Akashe

(57) Abstract :

The disclosed invention provides an approach of eye disease interpretation and classification. This approach can help practitioners in their conclusion and to provide early detection of eye disease. The model uses the statistical and the vessel features from the segmented and the pre-processed image to construct the feature vector. From the results through the proposed SVM classifier, it is evident that the proposed AMD detection system has better performance than the existing works with the values of 96% and 92% for overall classification accuracy for image datasets with different resolutions. The performance of model evaluated using Linear, Fine Gaussian and Quadratic SVM strategies. Classification of three eye diseases is achieved by using convolution neural network on standard and collected database of retinal fundus images. Classification is achieved by using deep learning approach. Deep Learning has been done using Transfer Learning approach. For convolution neural network classifier Testing Accuracy of 92.23% achieved (Figure 2).

No. of Pages : 29 No. of Claims : 10

(12) PATENT APPLICATION PUBLICATION

(21) Application
No.201921049666 A

(19) INDIA

(22) Date of filing of Application :03/12/2019

(43) Publication Date :
20/12/2019

(54) Title of the invention : SYSTEM OF SMART HELMET FOR MONITORING HEALTH OF A TWO-WHEELER RIDER AND OCCURRENCE OF COLLISION

(51)
International :G06K0007100000,H04L0029120000,B62J0099000000,B60W0050140000,A42B0003040000
classification
(31) Priority
Document :NA
No
(32) Priority :NA
Date
(33) Name
of priority :NA
country
(86)
International
Application :NA
No :NA
Filing
Date
(87)
International :NA
Publication
No
(61) Patent
of Addition
to
Application :NA
Number :NA
Filing
Date
(62)
Divisional to
Application :NA
Number :NA
Filing
Date

(71)**Name of Applicant**
:
**1)Dr. Sanjeev
Sharma**
Address of Applicant
:Director. School of
Information Technology,
Rajiv Gandhi
Praudyogiki
Vishwavidyalaya,
Bhopal, Madhya
Pradesh, India Madhya
Pradesh India
2)Dr. Piyush Shukla
**3)Dr. Prashant
Kumar Shukla**
**4)Dr. Mahesh
Panwar**
**5)Dr. Poonam
Sharma**
**6)Dr. Yadunath
Pathak**
(72)**Name of Inventor :**
**1)Dr. Sanjeev
Sharma**
2)Dr. Piyush Shukla
**3)Dr. Prashant
Kumar Shukla**
**4)Dr. Mahesh
Panwar**
**5)Dr. Poonam
Sharma**
**6)Dr. Yadunath
Pathak**

(57) Abstract :

The present invention relates to system of the smart helmet for monitoring the health of a two-wheeler rider and occurrence of a collision. The objective of the present invention is to overcome the inadequacies of the prior art in monitoring the health of a two-wheeler rider and occurrence of a collision. The system comprises an accelerometer sensor, a sensor module, mobile computing device, mobile connecting module, vehicle control module and a processing unit.

No. of Pages : 21 No. of Claims : 5

(12) PATENT APPLICATION PUBLICATION

(21) Application
No.201921049688 A

(19) INDIA

(22) Date of filing of Application :03/12/2019

(43) Publication Date :
20/12/2019

(54) Title of the invention : SYSTEM AND METHOD FOR CONSTRUCTIVE EFFORT ESTIMATION

(51)
International :G06F0016290000,G06F0016245700,G06T0005000000,G06T0007500000,H04N0005930000
classification
(31) Priority
Document :NA
No
(32) Priority :NA
Date
(33) Name
of priority :NA
country
(86)
International
Application :NA
No :NA
Filing
Date
(87)
International
Publication : NA
No
(61) Patent
of Addition
to
Application :NA
Number :NA
Filing
Date
(62)
Divisional to
Application :NA
Number :NA
Filing
Date

(71)**Name of Applicant :**
**1)Rabindranath
Tagore University**
Address of Applicant
:Mendua, Post: Bhojpur,
Near Bangrasiya
chouraha, Bhopal-
Chiklod Road, District:
Raisen, (M.P.)-464993,
India. Madhya Pradesh
India
(72)**Name of Inventor :**
1)Yatin Chaturvedi
2)Dr. Sitesh K. Sinha
3)Nitesh Baghel
**4)Devendra Singh
Rathore**

(57) Abstract :

The present invention relates to a system for constructive effort estimation, comprising of a storage module for storing a dataset from a repository site, an optimizing module for ranking the data, a normalization module for organizing the dataset, a de-noise module for removing noise, a partitioning module for dividing the de-noised data, a feature selection module for selecting feature(s) from the training data and ranked data, a processing module for processing the feature(s) and a display module for displaying the estimated constructive effort and the method for constructive effort estimation comprising the step of storing a dataset, ranking the data, organizing the dataset to minimize data redundancy, removing unwanted data from the organized data, dividing the de-noised data into testing data and training data, selecting feature(s) from the training data and ranked data; processing the feature(s) to estimate constructive effort and displaying the estimated constructive effort.

No. of Pages : 15 No. of Claims : 8

(12) PATENT APPLICATION PUBLICATION

(21) Application
No.201921049690 A

(19) INDIA

(22) Date of filing of Application :03/12/2019

(43) Publication Date :
20/12/2019

(54) Title of the invention : SYSTEM AND METHOD FOR IDENTIFYING KNUCKLES OF USERS

(51)
International :G01R0031280000,A61B0005145500,G06F0016532000,G09G0005360000,G06F0016000000
classification
(31) Priority
Document :NA
No
(32) Priority :NA
Date
(33) Name
of priority :NA
country
(86)
International
Application :NA
No :NA
Filing
Date
(87)
International
Publication : NA
No
(61) Patent
of Addition
to
Application :NA
Number :NA
Filing
Date
(62)
Divisional to
Application :NA
Number :NA
Filing
Date

(71)**Name of Applicant**
:
**1)Rabindranath
Tagore University**
Address of Applicant
:Mendua, Post: Bhojpur,
Near Bangrasiya
chouraha, Bhopal-
Chiklod Road, District:
Raisen, (M.P.)-464993,
India. Madhya Pradesh
India
(72)**Name of Inventor :**
1)Ankit Pandit
2)Ravitesh Mishra
3)Amrish Kumar
Singh
4)Jitendra Ahir

(57) Abstract :

The present invention relates to a system and method for knuckle identification, wherein the system comprising a storage unit for storing pre-defined data, a sensor for capturing an image of a user's knuckle, a controlling unit for generating a result by comparing the captured image with the pre defined data, a display unit for displaying the result. The method for aforementioned system comprises the steps of registration of the user is done by acquiring initial set of knuckle image and storing it in the storage unit. The user is authenticated by capturing the knuckle image by the sensor. The captured image is converted into matrix form by the control unit by computing eigenvectors; wherein a result is generated by comparing the matrix with the initial set, the result is displayed on the display unit.

No. of Pages : 11 No. of Claims : 6

(12) PATENT APPLICATION PUBLICATION

(21) Application
No.201921049691 A

(19) INDIA

(22) Date of filing of Application :03/12/2019

(43) Publication Date :
20/12/2019

(54) Title of the invention : PREDICTION DEVICE FOR SURFACE ROUGHNESS

(51)
International :B23H0009000000,G05B0013020000,C25D0017120000,G05B0019416000,B23H0005020000
classification
(31) Priority
Document :NA
No
(32) Priority :NA
Date
(33) Name
of priority :NA
country
(86)
International
Application :NA
No :NA
Filing
Date
(87)
International : NA
Publication
No
(61) Patent
of Addition
to
Application :NA
Number :NA
Filing
Date
(62)
Divisional to
Application :NA
Number :NA
Filing
Date

(71)**Name of Applicant**
:
**1)Rabindranath
Tagore University**
Address of
Applicant :Mendua,
Post: Bhojpur, Near
Bangrasiya chouraha,
Bhopal-Chiklod Road,
District: Raisen, (M.P.)-
464993, India. Madhya
Pradesh India
(72)**Name of Inventor** :
1)Rohit Pathak
2)Anurag Bagri
3)Swapnil Kumar
Singh
4)Manish Singh
Bharti

(57) Abstract :

The present invention relates to a prediction device for surface roughness, comprising a machining unit 1 associated with the device for removing metal from a work piece 2 electrochemically, the work piece 2 is placed inside the machining unit for crafting the work piece 2 in accordance to a user defined shape, at least a tool 3 installed in the machining unit 1 for dissolution of the work piece 2, a container 4 installed in the machining unit 1 for containing an electrolytic solution inside the container 4 for assisting the dissolution of the work piece 2; a microcontroller in association with the device for controlling various parameters such as voltage, feed rate and concentration during the dissolution of the work piece 2, and a prediction unit associated with the microcontroller for predicting a surface roughness of the work piece 2 using a fuzzy logic protocol.

No. of Pages : 12 No. of Claims : 8

(12) PATENT APPLICATION PUBLICATION

(21) Application
No.201921049692 A

(19) INDIA

(22) Date of filing of Application :03/12/2019

(43) Publication Date :
20/12/2019

(54) Title of the invention : METHOD FOR PREPARING STONE MATRIX ASPHALT

(51)
International :B29C0067240000,C04B0040020000,B29C0039000000,B29C0070120000,C04B0026160000
classification
(31) Priority
Document :NA
No
(32) Priority :NA
Date
(33) Name
of priority :NA
country
(86)
International
Application :NA
No :NA
Filing
Date
(87)
International
Publication : NA
No
(61) Patent
of Addition
to
Application :NA
Number :NA
Filing
Date
(62)
Divisional to
Application :NA
Number :NA
Filing
Date

(71)**Name of Applicant :**
**1)Rabindranath
Tagore University**
Address of Applicant
:Mendua, Post: Bhojpur,
Near Bangrasiya
chouraha, Bhopal-
Chiklod Road, District:
Raisen, (M.P.)-464993,
India. Madhya Pradesh
India
(72)**Name of Inventor :**
**1)Pooja Bodkhe
2)Dr. Brajesh Singh
3)Vikrant Dubey
4)Amit Kumar
Ahirwar**

(57) Abstract :

The present invention relates to a method for preparing a stone matrix asphalt, comprising the steps of; initially sampling two aggregates, grading the aggregates, drying, weighing the same, heating the aggregates in an oven at specific temperature, weighing a binder and heating it separately, separating out the aggregates from the oven, adding the separated aggregates in a mixing bowl, heating the aggregates under specific conditions, poring the binder and a jute fibre, and mixing manually to obtain a mixture, washing a mould, and fixing a filter paper and pouring the mixture into the mould to obtain a specimen, placing whole assembly of the mould on a compaction pedestal and hammering with a hammer, subjecting same treatment on reverse side of the specimen, transferring the specimen to smooth flat surface and cooling to room temperature to obtain a stone matrix asphalt.

No. of Pages : 17 No. of Claims : 7

(12) PATENT APPLICATION PUBLICATION

(21) Application
No.201921049693 A

(19) INDIA

(22) Date of filing of Application :03/12/2019

(43) Publication Date :
20/12/2019

(54) Title of the invention : VIDEO SHOT TRANSITION DETECTION METHOD

(51)
International :H04N0019117000,H04N0005140000,G06K0009000000,G11B0027280000,G06T0005400000
classification
(31) Priority
Document :NA
No
(32) Priority :NA
Date
(33) Name
of priority :NA
country
(86)
International
Application :NA
No :NA
Filing
Date
(87)
International : NA
Publication
No
(61) Patent
of Addition
to
Application :NA
Number :NA
Filing
Date
(62)
Divisional to
Application :NA
Number :NA
Filing
Date

(71)Name of Applicant
:
**1)Rabindranath
Tagore University**
Address of
Applicant :Mendua,
Post: Bhojpur, Near
Bangrasiya chouraha,
Bhopal-Chiklod Road,
District: Raisen, (M.P.)-
464993, India. Madhya
Pradesh India
(72)Name of Inventor :
**1)Dr. Varsha
Jatwani**
2)Ayonija Pathre
3)Dr. Shailja Sharma
4)Prajeet Sharma

(57) Abstract :

The present invention relates to a method for video shot transition detection in order to organize a video data into more compact and compressed form for meaningful extraction of information comprises the steps of inserting a video input in a user platform, segmenting video input into various image frames, applying gray scale conversion on a RGB input image, decomposition of the images into various images with abrupt transition and gradual transition by using DTCWT, computing histogram difference between each abrupt transition image frames, calculating pixel difference between each of the image related to gradual transition, contrasting histogram and pixel difference with a threshold value for identifying the video shot, whether correct detected or misdetected.

No. of Pages : 12 No. of Claims : 6

(12) PATENT APPLICATION PUBLICATION

(21) Application
No.201921049827 A

(19) INDIA

(22) Date of filing of Application :04/12/2019

(43) Publication Date : 20/12/2019

(54) Title of the invention : ATTENTV

(51)
International :H04N0021442000,H04N0021810000,H04N0021466000,H04N0021258000,H04N0021482000
classification
(31) Priority
Document :NA
No
(32) Priority :NA
Date
(33) Name
of priority :NA
country
(86)
International
Application :NA
No :NA
Filing
Date
(87)
International : NA
Publication
No
(61) Patent
of Addition
to :NA
Application :NA
Number :NA
Filing
Date
(62)
Divisional to
Application :NA
Number :NA
Filing
Date

(71)**Name of Applicant :**
1)RELU AI SYSTEMS PRIVATE LIMITED
Address of Applicant :VERTICA
C-1104, PALAVA, DOMBIVLI,
KALYAN,
THANE,MAHARASHTRA,INDIA,
PIN CODE: 421204 Maharashtra India
(72)**Name of Inventor :**
1)MAGESH POONDI GOVINDAN
2)SUJATHA RAMA SAMPAT GOVINDARAJAN
3)NIVEDHAA MAGESH

(57) Abstract :

ABSTRACT OF THE INVENTION - ATTENTV [0001] The present invention comprises of a computer, camera, an internet connection and a TV Tuner that are assembled together to define one single unit [0002] The television signals are processed through the TV Tuner to capture screen shots of channels being watched. The screen shots are sent to the cloud, where a artificial intelligence model built using Convolution Neural Network scans through the screen shot and identifies the channel name through its logo and logs the same. [0003] The viewers are scanned using the camera attached to the computer. Another artificial model built exclusively for each household identifies the viewer correctly and also logs whether the viewer is watching television or not and if the viewer is watching television logs their emotional status. Emotional status provides two broad metrics - Happy or neutral [0004] The data gathered - television channel data and the viewer data along with the time stamp together provide all the required data to measure the television viewership, the attention span of the viewers and their emotional status while watching television,

No. of Pages : 33 No. of Claims : 3

(12) PATENT APPLICATION PUBLICATION

(21) Application
No.201921050117 A

(19) INDIA

(22) Date of filing of Application :05/12/2019

(43) Publication Date :
20/12/2019

(54) Title of the invention : DESIGN AND DEVELOPMENT OF SUSTAINED RELEASE GEL USING POLYMER-SURFACTANT MIXTURES

(51)
International :A61K0047540000,A61K0009060000,G01N0030000000,A23L0033170000,B01D0015380000
classification
(31) Priority
Document :NA
No
(32) Priority :NA
Date
(33) Name
of priority :NA
country
(86)
International
Application :NA
No :NA
Filing
Date
(87)
International : NA
Publication
No
(61) Patent
of Addition
to
Application :NA
Number :NA
Filing
Date
(62)
Divisional to
Application :NA
Number :NA
Filing
Date

(71)Name of Applicant
:
**1)Dr Rajesh Z.
Mujoriya**
Address of
Applicant :School of
Pharmaceutical Science
& Research, Sardar
Patel University,
Balaghat, (M.P.), India
Madhya Pradesh India
**2)Dr Tarak Jayraj
Mehta**
3)Mr Shirish Wasu
**4)Mrs Smita
Venugopal**
(72)Name of Inventor :
**1)Dr Rajesh Z.
Mujoriya**

(57) Abstract :

The present inventions provide Catanionic drug-surfactant mixtures which provide novel method of obtaining sustained drug release from In-situ gels. Present Invention show that various commonly used drug compounds are able to form catanionic mixture together with oppositely charged surfactants. These mixture exhibited interesting phase behavior, where, among other structures, vesicles and large worm-like or branched micelles were found. The size of these aggregates makes the a potential means of sustaining the drug releases from gels, as only monomer drugs in equilibrium with larger aggregates were readily able to diffuse through the gel. When the diffusion coefficient for drug release from the formulation based upon a catanionic mixture was compared to that obtained for the drug substance and gel alone, the coefficient was some 10 to 100 times smaller.

No. of Pages : 20 No. of Claims : 3

(54) Title of the invention : KAPHA VAATATMKKA VETTO PITTA STHAN SAMUDABHAVO.

(51)
International :A61N0001360000,A23G0001360000,A61K0031355000,A23G0001480000,A61K0031122000
classification
(31) Priority
Document :NA
No
(32) Priority :NA
Date
(33) Name
of priority :NA
country
(86)
International
Application :NA
No :NA
Filing
Date
(87)
International : NA
Publication
No
(61) Patent
of Addition
to
Application :NA
Number :NA
Filing
Date
(62)
Divisional to
Application :NA
Number :NA
Filing
Date

(71)Name of Applicant :
**1)VAIDYARAJ RAKESH
PRAKASH NIGAM**
Address of Applicant :7,
LOKMANYA NAGAR, INDORE,
MADHYA PRADESH, INDIA - 452
009. Madhya Pradesh India
(72)Name of Inventor :
**1)VAIDYARAJ RAKESH
PRAKASH NIGAM**

(57) Abstract :

Abstract: KARAN VEDHAN SANSKAR is very popular among Solah (16) Sanskaras but due to ignorance we have adopted it to wear ornaments only by piercing External Ear (PINNA) at Lobule or at Hilex in childhood. Scientifically these piercing points are not correct. KARAN VEDHAN Sanskar is of Great importance for prevention of sound Health and to develop Immunity as well as for successful treatment of BRONCHIAL ASTHMA. VAIDYARAJ RAKESH PRAKASH NIGAM proved it by inventing correct point of piercing external Ear which is CONCHA in PINNA at center from where External Auricular Nerve branch of VAGUS Xth Cranial Nerve passes which is Sensory & Motor nerve controls the functions of its supply organs such as Lungs, Heart, Liver, Stomach, Spleen, Pancreas, Small & Large Intestine, Kidneys. Due to irregular life style & wrong food habits functions of above organs diminishes and we develops so many Health problems in J future even BRONCHIAL ASTHMA. Hence If we can activate functions of these Vital Organs Health problems of future can be solved. After elaborate search of its basis VAIDYARAJ RAKESH PRAKASH NIGAM given attention in Xth Cranial Nerve VAGUS and its Branches to stimulate VAGUS to activate Functions of its supply organs in search he found Posterior Auricular Nerve is Branch of VAGUS which passes externally from CONCHA in PINNA of External Ear. Hence he found that correct point of piercing PINNA in KARAN VEDHAN SANSKAR i.e. CONCHA. Thus he started giving treatment to patients suffering from BRONCHIAL ASTHMA with their consent by piercing CONCHA got wonderful results without any medicine. (Even after treatment patients stopped use of inhalers) After this success inventor recommends to improve Health and Immunity so as to prevent Heart & Lungs /Diseases by piercing at correct point CONCHA among children during 3 to 5 years of age.

No. of Pages : 10 No. of Claims : 6

(54) Title of the invention : WATER LETTUCE CONVERTER: WATER LETTUCE CAN BE CONVERTED TO BIOFUELSS, BIO-MANNURE AND OTHER REQUIRED THINGS

(51) International :A01H0005120000,A01D0044000000,C11B0013000000,C12N0001000000,A23L0031100000 classification
 (31) Priority Document :NA
 No
 (32) Priority Date :NA
 (33) Name of priority :NA
 country
 (86) International Application :NA
 No :NA
 Filing Date
 (87) International Publication :NA
 No
 (61) Patent of Addition to Application :NA
 Number :NA
 Filing Date
 (62) Divisional to Application :NA
 Number :NA
 Filing Date

(71)Name of Applicant :
1)MS. BACHHAV SNEHAL RAJENDRA
 Address of Applicant :D. Y. PATIL COLLEGE OF ENGINEERING, AKURDI, PUNE-411044, MH, INDIA
 Maharashtra India
2)MR. SACHIN J MANE
3)DR. ASHOK B. MORE
4)DR. SASWATI DATTA
5)MRS PALI SAHU
6)MRS PRAGATI A. MORE
7)MR AVINASH KISHOR SHENDGE
8)MR. ANIL HANUMANTU KOLI
9)MR. THOMBARE DATTATRAY BABAN
10)MS. KINJAL SANJAY KHAIRE
11)MR. KALPESH NANDKUMAR PATIL
 (72)Name of Inventor :
1)MS. BACHHAV SNEHAL RAJENDRA
2)MR. SACHIN J MANE
3)DR. ASHOK B. MORE
4)DR. SASWATI DATTA
5)MRS PALI SAHU
6)MRS PRAGATI A. MORE
7)MR AVINASH KISHOR SHENDGE
8)MR. ANIL HANUMANTU KOLI
9)MR. THOMBARE DATTATRAY BABAN
10)MS. KINJAL SANJAY KHAIRE
11)MR. KALPESH NANDKUMAR PATIL

(57) Abstract :

WATER LETTUCE CONVERTER: WATER LETTUCE CAN BE CONVERTED TO BIOFUELSS, BIO-MANNURE AND OTHER REQUIRED THINGS
 ABSTRACT The inventionWATER LETTUCE CONVERTER€ • The attacking plant water lettuce (Pistiastratiots) spreading in an adequate scope of water frequent can be utilized as substrate. This tropical plant can cause overspread over huge regions of water resources and inevitably leads to chain of issues like depletion of biodiversity, obstruction to waterways, and drainage system. In the ancient times, efforts were taken for removal of water lettuce using chemical, biological, and mechanical approaches for unfurl of, or suppression of, water lettuce. On the other hand, much awareness has been concentrated on the possible and constrains of utilizing water lettuce for variety of implementation. In this Invention, water lettuce (Pistiastratiots) was collected from the pond. The biomass was examined to determine their potent in producing Biofuels. The diagnosis of sugar present in (leaves and radicles) of water lettuce was carried out using fermentation and refining process. The refining was done with substrate (leaves and radicles) of the aquatic plant (water lettuce) along with inclusion of dry yeast (1 to 2%) to serve as booster for the fermentation process. It was found that radicles are given more efficient results compared to the leaves. Thus, the experiment influences a profitable value to water lettuce that are see-through from blocked waterways and remaining water lettuce waste after extraction of juice used as making of bio-manure.

No. of Pages : 20 No. of Claims : 5

(12) PATENT APPLICATION PUBLICATION

(21) Application No.201921050639
A

(19) INDIA

(22) Date of filing of Application :08/12/2019

(43) Publication Date : 20/12/2019

(54) Title of the invention : PERFORMANCE EVALUATION OF FIXED AND SUSPENDED ANAEROBIC FILTER MEDIA OF COMPACTED SEWAGE TREATMENT PROCESS

(51)
International :C02F0003280000,C02F0003100000,C02F0003300000,C02F0011040000,C02F0001280000
classification
(31) Priority
Document :NA
No
(32) Priority :NA
Date
(33) Name
of priority :NA
country
(86)
International
Application :NA
No :NA
Filing
Date
(87)
International : NA
Publication
No
(61) Patent
of Addition
to
Application :NA
Number :NA
Filing
Date
(62)
Divisional to
Application :NA
Number :NA
Filing
Date

(71)Name of Applicant :
**1)MR. SHRIKANT
MALHARARAO BHOSALE**
Address of Applicant
:DEPARTMENT OF TECHNOLOGY,
SHIVAJI UNIVERSITY, KOLHAPUR-
416004, MH, INDIA. Maharashtra India
2)MS.RAVEENA SURESH PUJARI
3)MR. PRAJWAL KURLE
4)DR. ASHOK BALKRISHNA
MORE
(72)Name of Inventor :
1)MR. PRAJWAL KURLE
2)DR. ASHOK BALKRISHNA
MORE
3)MR. SHRIKANT
MALHARARAO BHOSALE
4)MS.RAVEENA SURESH PUJARI

(57) Abstract :

PERFORMANCE EVALUATION OF FIXED AND SUSPENDED ANAEROBIC FILTER MEDIA OF COMPACTED SEWAGE TREATMENT PROCESS ABSTRACT [120] A method for treating wastewater through the use of powdered natural lignocelluloses materials (PNLM) and/or powdered kenaf (PK) The method includes mixing particulate kenaf with microorganisms to form an effect or composition, mixing the effect or composition with influent wastewater, oxygenating the wastewater, reacting the wastewater and clarifying the wastewater, resulting in improvement in the microbial population effect or composition in the wastewater. The anaerobic waste treatment systems as means for recovery of non-conventional energy are increasingly being recognized worldwide. Anaerobic decomposition is a biologically mediated process, indigenous to nature, and capable of being simulated for treating wastes emanating from municipal, agricultural, and industrial activities. Anaerobic digestion as applied in treatment of sewage sludge and other organic wastes represents the controlled application of a process. Although, anaerobic digesters have traditionally been used for many decades in the stabilization of sewage sludge, their successful and economic employment for the treatment of liquid wastes is only a recent phenomenon, arising from the development of new reactor designs. These concepts have led to development of various reactors, which are capable of retaining a much higher biomass concentration than traditional digesters. Making the sludge retention independent of the influent retention time makes this possible. The technological approaches to allow this condition of independent sludge retention time can be divided in to the following: Attachment of biomass on the media (filters, fluidized systems, and RBC configurations); 1. Non-attached biomass concept as suspended growth process (sludge blanket reactors 2. Contact process with sludge recycling). It is difficult to evaluate the advantages and disad.

No. of Pages : 23 No. of Claims : 9

(54) Title of the invention : USE OF NATURAL COAGULANTS FOR PRIMARY TREATMENT OF DAIRY WASTEWATER

(51)

International :C02F0001520000,C02F0001560000,C02F0001660000,C02F0009000000,C02F0001000000
classification

(31) Priority

Document :NA

No

(32) Priority :NA

Date

(33) Name

of priority :NA

country

(86)

International

Application :NA

No :NA

Filing

Date

(87)

International

Publication : NA

No

(61) Patent

of Addition

to

Application :NA

Number :NA

Filing

Date

(62)

Divisional to

Application :NA

Number :NA

Filing

Date

(57) Abstract :

USE OF NATURAL COAGULANTS FOR PRIMARY TREATMENT OF DAIRY WASTEWATER ABSTRACT [144] My Invention is fully related to Waste water produced, Coagulation is a unit process, it is method of mixing coagulant to water neutralize the electrical charges to form an insoluble gelatinous flocculent precipitate for absorbing and entraining suspended and colloidal partials of impurities is called coagulation In waste water treatment, coagulation is a process that occurs when a coagulant is added to water to destabilize colloidal suspensions. Conversely, flocculation involves the addition of polymers that clump the small, destabilized particles together into larger aggregates so that they can be more easily separated from the water. Coagulation is a chemical process that involves neutralization of charge whereas flocculation is a physical process and does not involve neutralization of charge. The coagulation-flocculation process can be used as a preliminary or intermediary step between other water or wastewater treatment processes like filtration and sedimentation. In this natural coagulants are used instead of chemical coagulants. Many coagulants are widely used in conventional water treatment processes, based on their chemical characteristics. These coagulants are classified into inorganic, synthetic organic polymers and natural coagulants. The two most commonly used primary coagulants are aluminum and iron salts(Okuda ET AL., 1999). In recent years, there has-been considerable interest in the development of natural coagulants such as Moringa oleifera(MO) and, T.foenum-graecum. By using natural coagulants, considerable savings in chemicals and sludge handling cost may be achieved (Diaz ET AL., 1999). Waste water produced from different processes, different quality and quantity and different volume. Nature of waste water contribute high biological oxygen demand (1300-1600 mg/lit), chemical oxygen demand (2500-3000 mg/lit), total solid (8000-10000), pH (6.5-8), chlorides, sulphates, oil and grease much higher than the permissible limits. It depends large quantity of milk proceed and type of product manufacturing. Especially the dairy whey contents are much more than the combined waste. The COD value of cheese whey is (50000-70000mg/lit) also waste water of dairy contains large quantities of milk constituents such as casein, inorganic salts, besides detergents and sanitizers used for washing. It has high sodium content from the use of caustic soda for cleaning Typical by-products include such as buttermilk, whey and their derivatives. Especially the dairy whey contents are much more than the combined waste. Dairy whey effluents contain dissolved sugars proteins and fats and possibly residues of additives. The key parameters are biochemical oxygen demand (BOD), with an average ranging from 0.8 to 2.5 kilograms per metric ton (kg/t) of milk in the untreated effluent; chemical oxygen demand (COD), which is normally about 1.5 times the BOD level; total suspended solids, at 100€1,000 milligrams per liter (mg/l); total dissolved solids: phosphorus (10€100 mg/l), and nitrogen (about 6% of the BOD level). Cream, butter, cheese, cured and Paneer whey production are major sources of BOD in wastewater.

No. of Pages : 26 No. of Claims : 9

(71)Name of Applicant :

1)MR. SHRIKANT MALHARARAO BHOSALE

Address of Applicant :DEPARTMENT OF TECHNOLOGY, SHIVAJI UNIVERSITY,KOLHAPUR, MH, INDIA Maharashtra India

2)MR. PRAMOD DEEPAK SUTAR**3)MR. (DR.) MOHIT DHIMAN****4)DR. ASHOK BALKRISHNA MORE**

(72)Name of Inventor :

1)MR. SHRIKANT MALHARARAO BHOSALE**2)MR. PRAMOD DEEPAK SUTAR****3)MR. (DR.) MOHIT DHIMAN****4)DR. ASHOK BALKRISHNA MORE**

(12) PATENT APPLICATION PUBLICATION

(21) Application
No.201921050753 A

(19) INDIA

(22) Date of filing of Application :09/12/2019

(43) Publication Date :
20/12/2019

(54) Title of the invention : IMPROVED RAPID COMPOSTING PROCEDURE WITH HIGH NUTRIENT USING VARIOUS WASTE MATERIALS

(51)
International:C05F0017020000,C05F0017000000,C05F0009040000,C02F0011160000,C02F00111400
classification 00
n
(31) Priority
Document :NA
No
(32) Priority :NA
Date
(33) Name
of priority :NA
country
(86)
International
Application :NA
No :NA
Filing
Date
(87)
International
Publication : NA
No
(61) Patent
of Addition
to
Application :NA
Number :NA
Filing
Date
(62)
Divisional
to
Application :NA
Number :NA
Filing
Date

(71)Name of Applicant :
**1)MR. SHRIKANT
MALHARARAO
BHOSALE**
Address of Applicant
:DEPARTMENT OF
TECHNOLOGY, SHIVAJI
UNIVERSITY,KOLHAPUR
, MH, INDIA Maharashtra
India
**2)MR. DIPAK
DASHARATH KOKARE
3)PROF. (DR.)
PRAKASH D. RAUT
4)MRS. PRAGATI
ASHOK MORE**
(72)Name of Inventor :
**1)MR. SHRIKANT
MALHARARAO
BHOSALE
2)MR. DIPAK
DASHARATH KOKARE
3)PROF. (DR.)
PRAKASH D. RAUT
4)MRS. PRAGATI
ASHOK MORE**

(57) Abstract :

IMPROVED RAPID COMPOSTING PROCEDURE WITH HIGH NUTRIENT USING VARIOUS WASTE MATERIALS
ABSTRACT [310] My InventionImproved rapid composting procedure with high nutrient using various waste materials • analysis and comparative study of the compost prepared using different materials in two composting models. Two models were prepared by using steel of $\frac{3}{4}$ hollow square section which acts as frame structure of the model and tarpaulin materials. The hollow square section frame was fabricated by welding. The model 1 was added with vegetables, Sewage Sludge, Dry leaves, Cow dung and Saw dust having quantities 10kg, 3 kg, 2.5 kg, 0.5 kg, and 250 gm. respectively. Whereas the model 2 was added with same above materials and quantities except the sewage sludge we used dairy sludge of 3 kg. The turning operation of composting material in the composting model was carried out after every 3rd day. The Invention results were analyzed by conducting various tests. During the composting process the parameters like pH, temperature and moisture contents were tested for an interval of 7 days. The results were found of the standard compost.

No. of Pages : 24 No. of Claims : 8

(12) PATENT APPLICATION PUBLICATION

(21) Application
No.201921051068 A

(19) INDIA

(22) Date of filing of Application :10/12/2019

(43) Publication Date :
20/12/2019

(54) Title of the invention : A SYSTEM AND METHOD FOR SELF-ADAPTING VIRTUAL STRUCTURING OF UNSTRUCTURED PARKING IN REAL-TIME

(51)
International :G08G0001140000,G08G0001000000,G06Q0010060000,G06Q0010080000,A01B0079000000
classification
(31) Priority
Document :NA
No
(32) Priority :NA
Date
(33) Name
of priority :NA
country
(86)
International
Application :NA
No :NA
Filing
Date
(87)
International : NA
Publication
No
(61) Patent
of Addition
to
Application :NA
Number :NA
Filing
Date
(62)
Divisional to
Application :NA
Number :NA
Filing
Date

(71)Name of Applicant
:
**1)Rahul Yashwant
Barhate**
Address of
Applicant :Flat no. 23,
Prabhavi Glades, off
Pashan Sus Road,
Pashan, Pune - 411021
Maharashtra India
**2)Akanksha
Surendra Kale**
**3)Kunal Atul
Khadilkar**
(72)Name of Inventor :
**1)Rahul Yashwant
Barhate**
**2)Akanksha
Surendra Kale**
**3)Kunal Atul
Khadilkar**

(57) Abstract :

ABSTRACT A SYSTEM AND METHOD FOR SELF-ADAPTING VIRTUAL STRUCTURING OF UNSTRUCTURED PARKING IN REAL-TIME Disclosed is a system and method for self-adapting virtual structuring of unstructured parking in real-time comprising a processor 201 and a memory 203. The processor is configured to execute instructions stored in the memory. The processor 201 receives a geographical map interface and locates a vacant area adapted for vehicle parking. The processor determines vehicle type and capacity. The processor plots virtual boundary points 407, 408, 409, 410 on a parking space 406. The processor creates parking slots 401, 402, 403, 404, 405 by plotting virtual grids inside the boundary points. The processor receives information of the incoming vehicle. The processor assigns a vacant parking slot 401 to the vehicle and further displays a navigating path towards it. The processor extracts and maps the geolocation of the parked vehicle with geolocation of the assigned parking slot. The processor dynamically updates the virtual parking slots in real-time. [To be published with Figure 4]

No. of Pages : 51 No. of Claims : 18

(12) PATENT APPLICATION PUBLICATION

(21) Application
No.201921051588 A

(19) INDIA

(22) Date of filing of Application :12/12/2019

(43) Publication Date :
20/12/2019

(54) Title of the invention : AN IMPROVED PROCESS FOR PREPARATION OF PURE ALDOXIME

(51)
International :H01L0051000000,B01J0027200000,C08K0003080000,C07H0001000000,C07C0029159000
classification
(31) Priority
Document :NA
No
(32) Priority :NA
Date
(33) Name
of priority :NA
country
(86)
International
Application :NA
No :NA
Filing
Date
(87)
International
Publication : NA
No
(61) Patent
of Addition
to
Application :NA
Number :NA
Filing
Date
(62)
Divisional to
Application :NA
Number :NA
Filing
Date

(71)Name of Applicant :
**1)Dr. Silviu
Pharmachem Pvt. Ltd.**
Address of Applicant
:M-169, Pimpale
Soudagar; Aundh post;
Pune; Maharashtra; India;
411027 Maharashtra
India
(72)Name of Inventor :
**1)Bhise Abhinav Sunil
2)Bhise Anil
Dnyanoba
3)Kadam Rohit
Rajendra
4)Bhangre Nakul
Gorakh
5)Gadakh Santosh
Madhav
6)Pawar Sagar
Mahadev**

(57) Abstract :

The present invention relates to an improved process for preparing aldoximes with general formula (I) with high purity and high yield. The improved process for preparing aldoxime is fast, simple, highly efficient, and reproducible.

No. of Pages : 25 No. of Claims : 7

(12) PATENT APPLICATION PUBLICATION

(21) Application
No.201921051663 A

(19) INDIA

(22) Date of filing of Application :13/12/2019

(43) Publication Date :
20/12/2019

(54) Title of the invention : DISTILLED CASHEW NUT SHELL LIQUID BASED, WATER THINABLE PHENALKAMINE AS CURING AGENT FOR EPOXY PAINT COMPOSITIONS

(51)
International :C08G0059560000,C07C0039150000,C07C0037000000,G05D0007060000,C08G0059500000
classification
(31) Priority
Document :NA
No
(32) Priority :NA
Date
(33) Name
of priority :NA
country
(86)
International
Application :NA
No :NA
Filing
Date
(87)
International : NA
Publication
No
(61) Patent
of Addition
to
Application :NA
Number :NA
Filing
Date
(62)
Divisional to
Application :NA
Number :NA
Filing
Date

(71)**Name of Applicant**
:
**1)NADKARNI
JAYRAM MANGESH**
Address of Applicant
:MANGESH ASHRAM,
13, AJMAL ROAD,
VILE PARLE (EAST),
MUMBAI - 400057,
MAHARASHTRA,
INDIA. Maharashtra
India
**2)NADKARNI
PRASAD JAYRAM**
(72)**Name of Inventor :**
**1)NADKARNI
JAYRAM MANGESH**
**2)NADKARNI
PRASAD JAYRAM**

(57) Abstract :

ABSTRACT Distilled cashew nut shell liquid based, water thinable phenalkamine as curing agent for epoxy paint composition A water-thinable phenalkamine curing agent for epoxy resins is produced by (a) Diels adler reaction of distilled cashew nut shell liquid for modification on side chain unsaturation with an unsaturated dicarboxylic acid; and (b) Mannich reaction between the phenolic compound intermediate with water soluble polyamine and with an aldehyde, preferably formaldehyde. The water soluble Mannich base is a reaction product of a polyamine containing at least two amino groups with a phenolic compound, with aid of an aldehyde. The water thinable phenalkamine forms a storage stable water solution and not a dispersion. The present invention offers a clean composition for the curing of epoxy resins in a closed environment that requires no volatile organic solvents during production and application as well,

No. of Pages : 25 No. of Claims : 10

(12) PATENT APPLICATION PUBLICATION

(21) Application
No.201921051700 A

(19) INDIA

(22) Date of filing of Application :13/12/2019

(43) Publication Date :
20/12/2019

(54) Title of the invention : METHOD AND SYSTEM FOR ELECTION OF A COORDINATOR NODE IN A DISTRIBUTED NETWORK

(51)
International :H04L0029080000,H04W0040240000,H02J0013000000,H04W0084180000,G06F0016951000
classification
(31) Priority
Document :NA
No
(32) Priority :NA
Date
(33) Name
of priority :NA
country
(86)
International
Application :NA
No :NA
Filing
Date
(87)
International : NA
Publication
No
(61) Patent
of Addition
to
Application :NA
Number :NA
Filing
Date
(62)
Divisional to
Application :NA
Number :NA
Filing
Date

(71)Name of Applicant
:
**1)INGLE, Rajesh
Baliram**
Address of
Applicant :Professor,
Department of
Computer Engineering,
Pune Institute of
Computer Technology,
Dhankawadi, Pune - 43,
Maharashtra, India.
Maharashtra India
**2)SUPASE, Shital
Subhashchandra**
(72)Name of Inventor :
**1)SUPASE, Shital
Subhashchandra**
**2)INGLE, Rajesh
Baliram**

(57) Abstract :

The present disclosure provides a system and method for election of a coordinator node in a distributed network. The method for election of the coordinator node in the distributed network includes providing a distributed data service operative based on a plurality of nodes. A selection of a set of nodes is received from an entity of said plurality of nodes. The plurality of nodes is associated with one or more parameters having respective weights. Further, one of a node of said set of nodes is elected as a coordinator node in said distributed data service in view of said first node having the respective weights higher than the weights of each of one or more nodes of the set of nodes, wherein the each of the one or more nodes of the set of nodes are selected as candidate nodes.

No. of Pages : 29 No. of Claims : 10

(12) PATENT APPLICATION PUBLICATION

(21) Application
No.201921051839 A

(19) INDIA

(22) Date of filing of Application :13/12/2019

(43) Publication Date :
20/12/2019

(54) Title of the invention : EMBOLIZATION COIL ASSEMBLY AND METHOD OF PREPARATION THEREOF

(51)
International :A61B0017120000,A61B0017000000,A61B0017221000,A61F0002962000,H01F0038120000
classification
(31) Priority
Document :NA
No
(32) Priority :NA
Date
(33) Name
of priority :NA
country
(86)
International
Application :NA
No :NA
Filing
Date
(87)
International : NA
Publication
No
(61) Patent
of Addition
to
Application :NA
Number :NA
Filing
Date
(62)
Divisional to
Application :NA
Number :NA
Filing
Date

(71)**Name of Applicant**
:
**1)Meril Life Sciences
Pvt. Ltd**
Address of Applicant
:Survey No. 135/139
Bilakhia House,
Muktanand Marg, Chala,
Vapi- 396191, Gujarat
Gujarat India
(72)**Name of Inventor :**
1)MINOCHA, Dr.
Pramod Kumar
2)KOTHWALA,
Deveshkumar
Mahendralal
3)DURANI,
Mohamadovesh
Mohamadyasin

(57) Abstract :

An embolization coil assembly (100) having an embolization coil (10) and a delivery system (20) is disclosed. The embolization coil (10) has a delivery and a deployed configuration. The embolization coil further includes a secondary coil (10a) having a first section (10a1) and a second section (10a2). The first section (10a1) and the second section (10a2) are linearly disposed in the delivery configuration and attain a first predefined shape and a second predefined shape respectively in the deployed configuration. The secondary coil (10a) is formed by reshaping a primary coil made from a superelastic shape memory material. The delivery system (20) includes a delivery wire (20a) having a tapered profile. A holding member (20b) is attached to the secondary coil (10a). An introducer sheath (20c) of the delivery system (20) is used for carrying the embolization coil (10) and the delivery wire (20a) at the target site.
FIG. 1

No. of Pages : 31 No. of Claims : 18

(12) PATENT APPLICATION PUBLICATION

(21) Application
No.201921051937 A

(19) INDIA

(22) Date of filing of Application :14/12/2019

(43) Publication Date :
20/12/2019

(54) Title of the invention : NOVEL INDOLE COMPOUNDS

(51)
International :C07D0403120000,C07D0209120000,A61K0031404000,C07D0209180000,C07D0209220000
classification

(31) Priority
Document :NA
No

(32) Priority
Date :NA

(33) Name
of priority :NA
country

(86)
International
Application :NA
No :NA

Filing
Date

(87)
International
Publication : NA
No

(61) Patent
of Addition
to
Application :NA
Number :NA

Filing
Date

(62)
Divisional to
Application :NA
Number :NA

Filing
Date

(71)Name of Applicant
:

**1)Dr. Thomas Asha
Byju**

Address of
Applicant :Department
of Pharmaceutical
Chemistry, Dr. D. Y.
Patil Institute of
Pharmaceutical Sciences
& Research, Sant
Tukaram Nagar, Pimpri,
Pune-411018,
Maharashtra, India
Maharashtra India

**2)Dr. Chitlange
Sohan S**

**3)Dr. D.Y.Patil
Institute of
Pharmaceutical
Sciences & Research**

(72)Name of Inventor :

**1)Dr. Thomas Asha
Byju**

2)More Ghansham S.

(57) Abstract :

ABSTRACT NOVEL INDOLE COMPOUNDS The present invention relates to novel indole compounds and the salts thereof used for the treatment of cancer. The invention also relates to processes for preparing these compounds, intermediates, processes for preparing such intermediates, and to compositions comprising at least one compound of general formula (I). Wherein, R1, R2, R3, m and n are as defined in description.

No. of Pages : 48 No. of Claims : 10

(12) PATENT APPLICATION PUBLICATION

(21) Application
No.201921051964 A

(19) INDIA

(22) Date of filing of Application :14/12/2019

(43) Publication Date :
20/12/2019

(54) Title of the invention : DUAL COATING ON MEDICAL IMPLANTS

(51)
International :A61K0008340000,A61K0031573000,A61K0031351000,D06M0015263000,A61K0009120000
classification
(31) Priority
Document :NA
No
(32) Priority :NA
Date
(33) Name
of priority :NA
country
(86)
International
Application :NA
No :NA
Filing
Date
(87)
International : NA
Publication
No
(61) Patent
of Addition
to
Application :NA
Number :NA
Filing
Date
(62)
Divisional to
Application :NA
Number :NA
Filing
Date

(71)Name of
Applicant :
**1)Meril Healthcare
Pvt. Ltd**
Address of
Applicant :Bilakhia
House, Muktanand
Marg, Chala, Vapi-
Gujarat 396191, India.
Gujarat India
(72)Name of Inventor
:
**1)MINOCHA, Dr.
Pramod Kumar**
**2)KOTHWALA,
Deveshkumar**
Mahendralal
**3)BHAGAT,
Chintan**
Bipinchandra

(57) Abstract :

ABSA therapeutic coating on a medical implant is disclosed. The coating includes a bottom layer and top layer. The bottom layer and the top layer include a nano formulation having at least one polymer in a concentration of 5 weight% - 95 weight%, at least one surfactant in a concentration of 1weight% - 10weight%. Further, the bottom layer includes at least one anti-bacterial agent in a concentration of 1 weight% - 60 weight% and the top layer at least one anti-inflammatory agent in a concentration of 01 weight% - 60 weight% dissolved in at least one solvent. The 50% to 70% of the anti-bacterial agent is released in 45-55 days of implantation from the bottom layer and the 85%-95% of the anti-inflammatory agent is released in 1-4 days of implantation at the treatment site from the top layer.

No. of Pages : 27 No. of Claims : 12

(12) PATENT APPLICATION PUBLICATION

(21) Application
No.201921052090 A

(19) INDIA

(22) Date of filing of Application :16/12/2019

(43) Publication Date :
20/12/2019

(54) Title of the invention : A TRAILER WITH HORIZOTAL DISCHARGING ARRANGEMENT WITH HYDRAULIC TAILGATE WHICH OPERATES IN AUTO SEQUENCES WHILE DISCHARGING.

(51)
International :B60P0001260000,F04B0001120000,B60P0001440000,E02B0008060000,B61D0003180000
classification

(31) Priority
Document :NA
No

(32) Priority :NA
Date

(33) Name
of priority :NA
country

(86)
International
Application :NA
No :NA

Filing
Date

(87)
International : NA
Publication
No

(61) Patent
of Addition
to
Application :NA
Number :NA

Filing
Date

(62)
Divisional to
Application :NA
Number :NA

Filing
Date

(71)**Name of Applicant :**
**1)SRBH MOTORS
PRIVATE LIMITED**

Address of Applicant
:DELHA MODE, NEXT
TO INDIAN OIL
PETROL PUMP, PO
SARLA NAGAR,
MAIHAR, SATNA-
485772, MADHYA
PRADESH, INDIA.
Madhya Pradesh India

(72)**Name of Inventor :**
**1)LALIT
WAANKHEDE
2)RAM MANOHAR
SINGH**

(57) Abstract :

Abstract It is a Box type trailer which is open from the top for loading the material. Lower part of trailer is narrowed to bottom and in the bottom part throughout length unique conveyer is placed. This conveyer is placed. This conveyer is having driving sprocket towards end and driven sprockets in the front of the trailer. Two sets of Chains are mounted in the parallel loop and interconnected with specially shaped profiles with abrasive resistant material in each respective links of both the chains. This loop along with across flats is rotated by two drive motors towards end. To enhance the required torque between drive shaft and hydraulic drive the gear box is placed. Under these across specially shaped profiles and the bed of the trailer, dampening layer is used as solid bearing surface to bear the load while allowing smooth sliding with low friction and same time provides shock absorbing characteristics as well. The controls are kept inside the cabin of the tractor. This electrical pendant is controlling electrical coils of hydraulic valves and thus operation is controlled.

No. of Pages : 9 No. of Claims : 4

(12) PATENT APPLICATION PUBLICATION

(21) Application
No.201921052171 A

(19) INDIA

(22) Date of filing of Application :16/12/2019

(43) Publication Date :
20/12/2019

(54) Title of the invention : SOLAR STILL

(51)
International :C02F0001140000,B01D0005000000,C02F0001040000,B01D0001000000,C02F0001180000
classification
(31) Priority
Document :NA
No
(32) Priority :NA
Date
(33) Name
of priority :NA
country
(86)
International
Application :PCT//
No :01/01/1900
Filing
Date
(87)
International : NA
Publication
No
(61) Patent
of Addition
to :NA
Application :NA
Number :NA
Filing
Date
(62)
Divisional to
Application :NA
Number :NA
Filing
Date

(71)Name of Applicant :
1)Dr. Smita Joshi
Address of Applicant
:Faculty of GTU affiliated
College 10, Laxdweep
Bungalaws Near Parth
Bungalaws, Vallabh
Vidyanagar-Anand
Gujarat-388120 India
Gujarat India
2)Dr. A R Jani
(72)Name of Inventor :
1)Dr. Smita Joshi
2)Dr. A R Jani

(57) Abstract :

Present invention relates to a novel solar still which is used for desalination of Brine/Saline water collector (6) as well as distillation of impure water to overcome the problem of inadequate availability of potable water. Present novel solar still is compact in design in which Brine/Saline water collector (6) is filled into S.S pan, charcoal is placed into Brine/Saline water collector (6) which fasten the evaporation by capillary effect and black body radiation. And Polycarbonate cone (3) is placed on the S.S pan. On the surface of Polycarbonate cone (3) Solar cell (4) are placed. Solar cell (4) and Mini Windmill (12) are used to generate electricity as a renewable source of energy, which is stored in Battery (10). Heater (11) is placed into the middle of the S.S pan which turns Brine/Saline water collector (6) into vapor and at the inner surface of Polycarbonate cone (3) the vapor gets condensed and distilled water is generated. By using distilled water collector (7) the distilled water is collected from one side of the Polycarbonate cone (3) and distilled water is stored into Distilled water storage tank (8). The input and output of the fluid is maintained by venturimeter (2).

No. of Pages : 16 No. of Claims : 9

(12) PATENT APPLICATION PUBLICATION

(21) Application
No.201921052196 A

(19) INDIA

(22) Date of filing of Application :16/12/2019

(43) Publication Date :
20/12/2019

(54) Title of the invention : THE ENERGY EFFICIENT STIRRER FOR DOMESTIC WATER TREATMENT PROCESSES

(51)
International :B01F0015000000,B01F0013080000,G09F0013220000,B01F0005020000,B01F0005200000
classification

(31) Priority
Document :NA
No

(32) Priority
Date :NA

(33) Name
of priority :NA
country

(86)
International
Application :NA
No :NA

Filing
Date

(87)
International
Publication : NA
No

(61) Patent
of Addition
to
Application :NA
Number :NA

Filing
Date

(62)
Divisional to
Application :NA
Number :NA

Filing
Date

(71)Name of Applicant :
**1)Dr.Santosh
Vyankatrao Agarkar**

Address of Applicant
:Near Unic Computer
Gandhi Nagar,
Chikhli,Dist.Buldhana-
443201 Maharashtra India

**2)Dr.Narendra
Purushottam Shinkar
3)Shubham Gajanan
Fendar**

(72)Name of Inventor :
**1)Shubham Gajanan
Fendar**

**2)Dr.Narendra
Purushottam Shinkar
3)Dr.Santosh
Vyankatrao Agarkar**

(57) Abstract :

The stirrer has many applications like mixing of two liquids, adsorption process etc. The main function of the stirrer is to speed up the liquid reaction or to form homogenous liquid mixture. In water treatment plant heavy stirrers are used for mixing of bleaching powder or chlorine in water, proper aeration of water. In rural and hilly area it is difficult to construct water treatment plant. In such cases the water available is prone to contamination. To purify such water or to mix medicines or chemical uniformly in water stirrer is used. But the stirrers available in market are non-automatic and some are motorized stirrer. It takes lots of time and efforts in case of manual stirrers while motorized stirrers are costly and difficult to maintain. Hence there is requirement of automatic user friendly, ecofriendly, energy efficient, easy to install and affordable which will be useful in water treatment in rural area and water based laboratory experiments. Since this stirrer is powered by solar cells or wind, there is not requirement of any external power supply.

No. of Pages : 10 No. of Claims : 7

(12) PATENT APPLICATION PUBLICATION

(21) Application
No.201921052290 A

(19) INDIA

(22) Date of filing of Application :17/12/2019

(43) Publication Date :
20/12/2019

(54) Title of the invention : DESIGN AND DEVELOPMENT OF MODIFIED BRAKE PEDAL ASSEMBLY FOR EARLY DETECTION OF BRAKING PHENOMENON.

(51)
International :B60Q0001440000,B60T0007220000,B60T0007060000,B60W0010180000,B60T0017040000
classification
(31) Priority
Document :NA
No
(32) Priority :NA
Date
(33) Name
of priority :NA
country
(86)
International
Application :NA
No :NA
Filing
Date
(87)
International : NA
Publication
No
(61) Patent
of Addition
to
Application :NA
Number :NA
Filing
Date
(62)
Divisional to
Application :NA
Number :NA
Filing
Date

(71)Name of Applicant
:
**1)Mr.Vivekanand
Arun Naikwadi.**
Address of Applicant
:Flat No 705 GV7 Apt
Phase 3,Ambegaon
bk,Pune Maharashtra
India
**2)Mr.Chetan Kishor
Patil.**
**3)Mr.Abhijeet
Mukund Shirude.**
**4)Mr.Prashant
Mahadev Patane.**
**5)Mr.Gautam Jalba
Narwade.**
(72)Name of Inventor :
**1)Mr.Vivekanand
Arun Naikwadi.**
**2)Mr.Chetan Kishor
Patil.**
**3)Mr.Abhijeet
Mukund Shirude.**
**4)Mr.Prashant
Mahadev Patane.**
**5)Mr.Gautam Jalba
Narwade.**

(57) Abstract :

Abstract- A modified Brake pedal assembly consists of a Innovative early detection foot movement analyzing device which will detect when brake is going to apply thus early imitation signal will provided to rear brake lights so as possibility of narrow braking collision can be avoided. The braking distance is vital component in any braking systems, the current invention will help the vehicle in rear to identify the possible braking of front vehicle before the front vehicle driver actually hits the brake to slow down or stop the vehicle.

No. of Pages : 10 No. of Claims : 8

(54) Title of the invention : THE SAFETY BELT FOR INDUSTRIAL ROBOTS

(51) International :B25J0013080000,B25J0009160000,G06N0003000000,B25J0019060000,B25J0019000000 classification
 (31) Priority Document :NA
 No
 (32) Priority Date :NA
 (33) Name of priority country :NA
 (86) International Application No :PCT// :01/01/1900
 Filing Date
 (87) International Publication No :NA
 (61) Patent of Addition to Application Number :NA :NA
 Filing Date
 (62) Divisional to Application Number :NA :NA
 Filing Date

(71)Name of Applicant :
1)Balu Patil
 Address of Applicant :Mechanical Engineering Department, CMR Institute of Engineering, 132 AECS Layout, ITPL main road, Kundalhalli Bangalore 560037 Maharashtra India
2)Ashish Gaikwad
3)Akash Anil Walde
4)Kartik N. Argulwar
5)Ajinkya Ravindra Kottawar
6)Chaitanya Gajbhiye
 (72)Name of Inventor :
1)Balu Patil
2)Ashish Gaikwad
3)Akash Anil Walde
4)Kartik N. Argulwar
5)Ajinkya Ravindra Kottawar
6)Chaitanya Gajbhiye

(57) Abstract :

Industrial robots are generally used worldwide in the automation industries for faster, accurate and repeated operations in relatively static environments for over 30 years. So now days, proximity interaction between industrial robots and human operators is latest trends in research which encouraged many technological innovations to convert these robots for human robot platforms. This technique can be used to solve many industrial issues. One of them is accidents caused by Human- Robot interactions. In majority industries human and robots shares the same work environment which results chances of accidents between human and robots if robots are not equipped with proper protection. In this work, a new method is proposed to avoid collisions between human and robot in automation industries. Today many options are available in market which reduces human robot collisions but most of them are either costly or difficult to integrate with the system. In order to add safety feature in the industrial robots, either programming has to be changed or internal hardware. The widely used industrial robots don't accept such changes. So the present invention uses proximity IR sensors and microcontroller which are mounted on safety belt. The safety belt is applied on industrial robot. The proximity sensor is connected to the microcontroller in order to give the position of human in terms of electrical signals. The output signals from microcontroller are given to the robotic controller. According to the algorithm dumped in microcontroller and robotic controller, these controllers moves robotic arm in order to avoid human robot contact.

No. of Pages : 17 No. of Claims : 6

(12) PATENT APPLICATION PUBLICATION

(21) Application
No.201921052318 A

(19) INDIA

(22) Date of filing of Application :17/12/2019

(43) Publication Date :
20/12/2019

(54) Title of the invention : NOVEL METHOD OF GENERATION OF LYMPHO-MYELOID NICHES AND THEIR APPLICATIONS THEREOF

(51)
International :G01N0033500000,A61K0035150000,A61K0035280000,C07D0301120000,A23L0005000000
classification
(31) Priority
Document :NA
No
(32) Priority :NA
Date
(33) Name
of priority :NA
country
(86)
International
Application :NA
No :NA
Filing
Date
(87)
International : NA
Publication
No
(61) Patent
of Addition
to
Application :NA
Number :NA
Filing
Date
(62)
Divisional to
Application :NA
Number :NA
Filing
Date

(71)**Name of Applicant**
:
**1)NATESAN,
Senthilkumar**
Address of
Applicant :A303 Swagat
Blossom 3BHK, Near
Aashka Hospital,
Sargasan, Gandhinagar,
Gujarat- 382421, India
Gujarat India
(72)**Name of Inventor :**
**1)NATESAN,
Senthilkumar**

(57) Abstract :

NOVEL METHOD OF GENERATION OF LYMPHO-MYELOID NICHES AND THEIR APPLICATIONS THEREOF

ABSTRACT The present invention relates to novel method of generating Lympho-Myeloid Niches (LMN) from peripheral blood mononuclear cell (PBMC). The present invention relates to a method of generating macrophages, myeloid cells and T cell from Lympho-Myeloid Niches (LMN). The present invention also describes its application for developing novel cell based therapies, gene therapies, gene edited therapies for the treatment of various disease conditions using the Lympho-Myeloid Niches (LMN), and/or the cells generated from Lympho-Myeloid Niches (LMN) or their culture.

No. of Pages : 45 No. of Claims : 13

(12) PATENT APPLICATION PUBLICATION

(21) Application
No.201921052332 A

(19) INDIA

(22) Date of filing of Application :17/12/2019

(43) Publication Date :
20/12/2019

(54) Title of the invention : VULCANIZING FIXTURE MACHINE FOR TYRE AND DETECTION METHOD THEREOF

(51)
International :H01M0004587000,G11B0007000000,B29D0030060000,A61K0031575000,H01M0004020000
classification
(31) Priority
Document :NA
No
(32) Priority :NA
Date
(33) Name
of priority :NA
country
(86)
International
Application :NA
No :NA
Filing
Date
(87)
International : NA
Publication
No
(61) Patent
of Addition
to
Application :NA
Number :NA
Filing
Date
(62)
Divisional to
Application :NA
Number :NA
Filing
Date

(71)Name of
Applicant :
**1)Padmakar
Pachorkar**
Address of
Applicant :Assistant
Professor, Department
of Mechanical
Engineering, IES
College of Technology,
Bhopal, India Madhya
Pradesh India
**2)Dr. Premanand
Singh Chauhan**
**3)Dr. Avadesh
Kumar Sharma**
**4)Dr. Rupesh
Chalishaonkar**
**5)Yogendra Singh
Rajpoot**
(72)Name of Inventor
:
**1)Padmakar
Pachorkar**
**2)Dr. Premanand
Singh Chauhan**
**3)Dr. Avadesh
Kumar Sharma**
**4)Dr. Rupesh
Chalishaonkar**
**5)Yogendra Singh
Rajpoot**

(57) Abstract :

The present invention relates to vulcanizing fixture machine for tyre and detection method thereof. The objective of the present invention is to overcome the inadequacies of the prior arts in vulcanizing fixture machine.

No. of Pages : 24 No. of Claims : 1

(12) PATENT APPLICATION PUBLICATION

(21) Application
No.201924050151 A

(19) INDIA

(22) Date of filing of Application :05/12/2019

(43) Publication Date :
20/12/2019

(54) Title of the invention : SYNTHETIC FIBER TREATMENT AGENT AND SYNTHETIC FIBER

(51)
International :D06M0013224000,D06M0015530000,A61K0008600000,C08K0005100000,C08F0002500000
classification
(31) Priority
Document :2018-233078
No
(32) Priority
Date :13/12/2018
(33) Name
of priority :Japan
country
(86)
International
Application :NA
No :NA
Filing
Date
(87)
International
Publication : NA
No
(61) Patent
of Addition
to
Application :NA
Number :NA
Filing
Date
(62)
Divisional to
Application :NA
Number :NA
Filing
Date

(71)Name of
Applicant :
**1)TAKEMOTO
YUSHI KABUSHIKI
KAISHA**
Address of
Applicant :2-5, Minato-
machi, Gamagori-shi,
Aichi-ken 443-8611,
Japan. Japan
(72)Name of Inventor
:
**1)KATO, Gakuto
2)SUZUKI, Chihiro
3)FUKUOKA,
Takuya**

(57) Abstract :

Provided is a synthetic fiber treatment agent that contains a sulfur-containing ester compound which is an ester compound formed of a C6-22 Guerbet alcohol and at least one selected from the group consisting of an organic acid having elemental sulfur in a molecule thereof and an ester-forming derivative of an organic acid having elemental sulfur in a molecule thereof. The synthetic fiber treatment agent contains the sulfur-containing ester compound as a smoothing agent, a nonionic surfactant, and an anionic surfactant. The anionic surfactant contains an organic sulfonate. Where the total content of the smoothing agent, the nonionic surfactant, and the anionic surfactant is taken as 100% by mass, the proportion of the sulfur-containing ester compound is 0.01 to 50% by mass, and the proportion of the organic sulfonate is 0.5 to 5% by mass.

No. of Pages : 26 No. of Claims : 6

(54) Title of the invention : A MILD, NONTOXIC PROCESS FOR DEBITTERING ASTRINGENT PRODUCE TO MAKE IT PALATABLE

(51)
International :A23L0033105000,A61K0008970000,A23L0011300000,A23L0019000000,A23K0010370000
classification

(31) Priority
Document :62/776,701
No

(32) Priority :07/12/2018
Date

(33) Name
of priority :U.S.A.
country

(86)
International
Application :NA
No :NA
Filing
Date

(87)
International : NA
Publication
No

(61) Patent
of Addition
to
Application :NA
Number :NA
Filing
Date

(62)
Divisional to
Application :NA
Number :NA
Filing
Date

(71)Name of Applicant :
1)Jivaraj Sutaria
Address of Applicant :NISARG
PLOT NO. 28 RAJKOT ROAD
SHIHOR Gujarat India Gujarat India

(72)Name of Inventor :
1)Gordhanbhai Nathalal Patel
2)Julia Koleda
3)Jivaraj Sutaria

(57) Abstract :

We consume a wide variety of fruits in large quantities. However, we discard their non-palatable seeds and peels. Many of these non-palatable fruits, leaves, peels, seeds, roots, barks and kernels (referred herein as non-palatable produce), e.g., mango seed kernel (MSK) and avocado seed, are discarded due to their astringency or bitterness. However, many non-palatable produce are not only highly nutritious and therapeutic but they can be worth billions of dollars. If non-palatable produce are made palatable, they can provide highly nutritious food, disease preventing therapeutic chemicals worth billions of dollars and minimize pollution. We have developed a simple, non-hazardous, green, mild and almost universal process of debittering many non-palatable astringent produce. This process involves treating the non-palatable produce with baking soda (sodium bicarbonate) followed by a carboxylic acid, such as citric acid or lemon juice. The debittered solid food is not astringent or bitter and it is highly nutritious, mainly composed of protein, carbohydrate and fat while the extract is an excellent health drink, rich in vitamins, minerals and phytochemicals/therapeutic chemicals. This process uses household food additives and can be done by almost anybody at home. A variety of nutritious dishes, such as bread, curries and therapeutic drinks can be made from the debittered produce. The process of debittering astringent produce appears to be almost universal. The process can be used for making a large number of non-palatable produce palatable around the world.

No. of Pages : 39 No. of Claims : 7

(12) PATENT APPLICATION PUBLICATION

(21) Application No.201927015606 A

(19) INDIA

(22) Date of filing of Application :18/04/2019

(43) Publication Date : 20/12/2019

(54) Title of the invention : METHOD OF ESTIMATING STRENGTH OF BAKING-TREATED FORMING PART

(51) International classification	:G01N 3/00,G06F 17/50	(71) Name of Applicant : 1)JFE STEEL CORPORATION Address of Applicant :2-3, Uchisaiwai-cho 2-chome, Chiyoda-ku Tokyo 1000011 Japan
(31) Priority Document No	:2016-209313	
(32) Priority Date	:26/10/2016	
(33) Name of priority country	:Japan	(72) Name of Inventor :
(86) International Application No	:PCT/JP2017/027925	1)AGEBA Ryo
Filing Date	:01/08/2017	2)ISHIWATARI Akinobu
(87) International Publication No	:WO 2018/078996	
(61) Patent of Addition to Application Number	:NA	
Filing Date	:NA	
(62) Divisional to Application Number	:NA	
Filing Date	:NA	

(57) Abstract :

Provided is a baked-molded-product strength estimating method for estimating the strength of a baked molded product obtained by subjecting to a baking process a press-molded product of a steel sheet that hardens by being baked. This strength estimating method comprises: a step (S1) for obtaining a relationship between pre-strain and material characteristics of a steel sheet that hardens by being baked; a step (S3) for calculating a uniaxial-equivalent plastic strain in the course of press-molding a press-molded product (1); a step (S5) for obtaining the maximum value of the uniaxial-equivalent plastic strain in a strain path in the course of press-molding; a step (S7) for setting to the press-molded product (1) post-bake-hardening material characteristics by employing the obtained maximum value; and a step (S9) for estimating a strength of a baked molded product by performing strength analysis of the press-molded product (1) to which the post-bake-hardening material characteristics have been set.

No. of Pages : 20 No. of Claims : 2

(12) PATENT APPLICATION PUBLICATION

(21) Application
No.201841002956 A

(19) INDIA

(22) Date of filing of Application :25/01/2018

(43) Publication Date :
20/12/2019

(54) Title of the invention : SYSTEMS AND METHODS FOR DIAGNOSIS OF MULTI-CELL BATTERIES

<p>(51) International :G01R0031392000,H01M0004580000,G01R0031382000,G01R0031360000,H02J0007000000 classification (31) Priority Document :NA No (32) Priority :NA Date (33) Name of priority :NA country (86) International Application :PCT// No :01/01/1900 Filing Date (87) International Publication : NA No (61) Patent of Addition to Application :NA Number :NA Filing Date (62) Divisional to Application :NA Number :NA Filing Date</p>	<p>(71)Name of Applicant : 1)IVROOM POWER PRIVATE LIMITED Address of Applicant :#356, G-BLOCK, SONESTA MEADOWS, THUBARAHALLI EXTENSION ROAD, THUBARAHALLI, BANGALORE-560 066, KARNATAKA, INDIA Karnataka India (72)Name of Inventor : 1)PRABHAKAR SATHUJODA 2)KRISHNARAO DHURI 3)PARTHIBAN P</p>
---	--

(57) Abstract :

All multi-cell (Li-Ion, Li-Titanate, Lithium iron phosphate, etc.) batteries are equipped with Battery Management System (BMS), which helps for safer operation and improving longevity. Generally, the monitoring happens at module (a group of cells) level and predicts overall health of battery. In this disclosure, the systems and methods are proposed for monitoring health of each cell. This is very useful for very large capacity batteries, where individual cells can be replaced to save whole battery. For monitoring the health of the battery 101, traditional the rate of State of the Charge (SOC) drop approach is used. The sensor used in this system are Hall based current sensor 104, Infrared camera 105 and acoustic sensor 166. Current 104 and Infrared (IR) camera 105 sensors are mounted on the slides which move with the help of gantry 102. This helps for using few sensors for very large capacity battery. The current sensor measures the current without any power loss, IR camera measure the temperature distribution over complete battery surface and acoustic sensors detects occurrence of sparks, if any. The sensor data is sent to local electronic board 106 wirelessly. The data from the electronic board is send to sever 111 on the cloud. The diagnosis analysis is being done at two places at local electronic board and server. An indirect method for cell level SOC determination from line current data is given. The method is outlined for detailed diagnosis of the battery.

No. of Pages : 31 No. of Claims : 9

(12) PATENT APPLICATION PUBLICATION

(21) Application
No.201841032739 A

(19) INDIA

(22) Date of filing of Application :31/08/2018

(43) Publication Date :
20/12/2019

(54) Title of the invention : HYDRO TURBINE ELECTRIC GENERATOR WITH SPLIT CYLINDER, FREE PISTON INTERNAL COMBUSTION ENGINE, WITH

(51) International :F16F0009060000,F01L0009020000,C02F0003300000,F02B0071020000,C02F0001680000 classification

(31) Priority Document :NA
No

(32) Priority Date :NA

(33) Name of priority :NA
country

(86) International Application :NA
No :NA

Filing Date (87)

International Publication : NA
No

(61) Patent of Addition to Application :NA
Number :NA
Filing Date

(62) Divisional to Application :NA
Number :NA
Filing Date

(71)Name of Applicant :
**1)P L AHOBALA
NARASIMHAMURTHY**
Address of Applicant
:12,CANARA BANK
LAYOUT MAIN ROAD,
VIRUPAKASHAPURA,
VIDYARANYAPURA
(POST), KODIGEHALLI
,BANGALORE,
KARNATAKA INDIA Pin
code 560097 Karnataka
India

(72)Name of Inventor :
**1)P L AHOBALA
NARASIMHAMURTHY**

(57) Abstract :

The present invention provides an internal combustion engine with a split cylinder and free piston. The internal combustion engine (100) comprises a first chamber (200) having pumping means (202) disposed therein, wherein the first chamber (200) is configured to pump air or a charge, a second chamber (400) having second piston (402) disposed therein, the first chamber (200) is connected to and in fluid communication with the second chamber (400) and is configured to receive the air or charge from the first chamber (200), and a third chamber (600) having third piston (602) disposed therein, the third chamber (600) is configured to receive a fluid therein and the third piston (602) is operably coupled to the second piston (402), and a second locking mechanism (1000) and/or a first locking mechanism (800). FIG. 1

No. of Pages : 76 No. of Claims : 22

(12) PATENT APPLICATION PUBLICATION

(21) Application No.201941000316
A

(19) INDIA

(22) Date of filing of Application :03/01/2019

(43) Publication Date : 20/12/2019

(54) Title of the invention : AN ASSISTANCE SYSTEM FOR PERSONS WITH DISABILITIES

(51)

International :A61B0005000000,A61B0005160000,A61B0005047600,A61F0004000000,A61B0005047800
classification

(31) Priority

Document :NA
No

(32) Priority :NA
Date

(33) Name
of priority :NA
country

(86)

International
Application :NA
No :NA

Filing
Date

(87)

International : NA
Publication
No

(61) Patent
of Addition
to
Application :NA
Number :NA

Filing
Date

(62)

Divisional to
Application :NA
Number :NA

Filing
Date

(71)Name of Applicant :

**1)SRM INSTITUTE OF SCIENCE
AND TECHNOLOGY**

Address of Applicant

:Kattankulathur, Chennai Tamil Nadu
India

(72)Name of Inventor :

**1)MOHAN, Uma
2)THAVASI, Sheela
3)SETHURAMALINGAM, Prabhu**

(57) Abstract :

ABSTRACT AN ASSISTANCE SYSTEM FOR PERSONS WITH DISABILITIES The present invention relates to the field of intelligent assistive systems and the present disclosure envisages an assistance system for persons with disabilities. The system (100) comprises a personalized computing device (110), a single acquisition device (104) and a task detection module (108). The personalized computing device (110) is configured to display a plurality of items. The signal acquisition device (104) comprises a plurality of electrodes (105) to record electroencephalogram (EEG) activity of the subject's brain such as eye movement and blinking of eyes and is further configured to generate a control signal. The task detection module (108) is installed on the personalized computing device (110) and is communicatively coupled to the signal acquisition device (104). The task detection module (108) is configured to receive the control signals from the signal acquisition device (104) to identify the item selected by the subject based on the blinking of eyes

No. of Pages : 20 No. of Claims : 10

(12) PATENT APPLICATION PUBLICATION

(21) Application
No.201941025521 A

(19) INDIA

(22) Date of filing of Application :27/06/2019

(43) Publication Date :
20/12/2019

(54) Title of the invention : CONTINUOUS RECHARGEABLE SEAWATER BATTERY SYSTEM

(51)
International :H02J0007000000,C25B0001000000,H01M0008180000,C02F0001000000,H01M0010050000
classification
(31) Priority
Document :NA
No
(32) Priority :NA
Date
(33) Name
of priority :NA
country
(86)
International
Application :NA
No :NA
Filing
Date
(87)
International
Publication : NA
No
(61) Patent
of Addition
to
Application :NA
Number :NA
Filing
Date
(62)
Divisional to
Application :NA
Number :NA
Filing
Date

(71)Name of Applicant
:
**1)Vel Tech
Rangarajan Dr.
Sagunthala R&D
Institute of Science and
Technology**
Address of Applicant
:No.42, Avadi Vel Tech
Road, Avadi, Chennai -
600 062 Tamil Nadu,
India Tamil Nadu India
(72)Name of Inventor :
**1)Dr. Shankar
Raman Dhanushkodi
2)V.Veeran**

(57) Abstract :

CONTINUOUS RECHARGEABLE SEAWATER BATTERY SYSTEM The present invention describes a Continuous, Rechargeable Seawater Battery System. To desalinate seawater, an electrolytic (charging) and electrochemical (discharging) cell are connected symmetrically in the system. The cell configuration comprises a salt chamber, organic electrolyte chamber, membranes, electrode layers, and metal foils. A manifold with shutter is placed between two cells to enable the continuous operation. The salt chamber is sandwiched between an anion exchange and superionic membranes. Electrode layers are constructed on the surface of the metal foil and catalysts such as Ru/C, Pt/C, Pd/C, etc are used to promote the electrode processes. Both electrolytic and electrochemical modules are assembled adjacent to each other with gaskets. Operating CRSBS in charging mode produces hydrochloric acid and portable water. Desalinated portable water is collected at the outlet of the central chamber. Sodium hydroxide is produced only when the cell is discharged. Reversing the entire cell operation shall produce clean renewable electricity. Main illustrative figure is Fig.1(b)

No. of Pages : 34 No. of Claims : 8

(12) PATENT APPLICATION PUBLICATION

(21) Application No.201941031640
A

(19) INDIA

(22) Date of filing of Application :05/08/2019

(43) Publication Date : 20/12/2019

(54) Title of the invention : COMPUTERIZED POINT SYSTEM IDEOGRAPH BIBLIOPHILE WITH MARGINAL PATRONIZE

(51)

International :G09B0021000000,G06Q0030000000,E04G0021320000,G06Q0020200000,G06F0003010000
classification

(31) Priority

Document :NA
No

(32) Priority :NA
Date

(33) Name
of priority :NA
country

(86)

International
Application :NA
No :NA

Filing
Date

(87)

International : NA
Publication
No

(61) Patent
of Addition
to
Application :NA
Number :NA

Filing
Date

(62)

Divisional to
Application :NA
Number :NA

Filing
Date

(71)Name of Applicant :

1)Dr. G.N.KODANDA RAMAIAH

Address of Applicant :Chief
Coordinator, New Gen IEDC, Kuppam
Engineering College, K.E.S. Nagar,
P.B. Natham (Post, Kuppam (Mandal),
Chittoor (Dist) Andhra Pradesh India

2)S.NANDA KISHOR

3)Dr. Thangadurai N

(72)Name of Inventor :

1)Dr. G.N.KODANDA RAMAIAH

2)Dr. PRABHAKAR V

HUNAGUND

3)Dr. S.A.K. JILANI

4)S.NANDA KISHOR

5)D. SIVA KUMAR

6)Dr. K.T.DEEPAK

7)B.P YOGESHWARI

8)Y MADAN MOHAN REDDY

9)S CHARAN

10)E PAVITHRA

11)Dr. Thangadurai N

(57) Abstract :

Point system is a material composition framework utilized by a visually impaired and the outwardly debilitated. They can compose point system with the first slate and stylus or type it on a point system essayist. In this undertaking, we are building up another philosophy utilizing a Point system framework so as to peruse a message for visually impaired individuals. Computerized point system peruses are getting prominent overall step by step among the outwardly debilitated individuals. A servo engine based remote computerized point system was structured. Presently accessible servo engine based and piezoelectric based point system have a few issues with their mechanical highlights and cost separately. This is about the plan and development of a Wireless computerized point system device with settled mechanical usefulness, remote information move accessibility and much lower cost than accessible computerized point system of this sort. This proposed work guarantees right mechanical usefulness, exactness, security, quicker information move and lower cost. The learning begins at an extremely youthful age; subsequently we have focused on youngsters between the ages 3 to 6 and instill the fundamental ideas of point system in our local language Tamil/Telugu, to such an extent that they prosper later on. Also made a haptic interface with the assistance of arduino board and utilized laptops for automatic discourse acknowledgment that causes them in dynamic learning. This included learning in different trouble levels, for example, easy, intermediate, and hard which would spring.

No. of Pages : 9 No. of Claims : 2

(54) Title of the invention : COMPOSITION OF A HYDRAULIC CIRCUIT AND EMPANELMENT OF ENERGY CONSERVATION APPROACHES USING VOLATILE DENSITY DRIVE FOR CNC APPARATUS

(51)
International :F15B0021080000,F04D0015000000,B29C0045670000,B29C0045820000,F04D0027020000
classification
(31) Priority
Document :NA
No
(32) Priority :NA
Date
(33) Name
of priority :NA
country
(86)
International
Application :NA
No :NA
Filing
Date
(87)
International :NA
Publication :NA
No
(61) Patent
of Addition
to :NA
Application :NA
Number :NA
Filing
Date
(62)
Divisional to
Application :NA
Number :NA
Filing
Date

(71)Name of Applicant :
1)Dr. S. Denis Ashok
Address of Applicant :Professor, Department of Design
and Automation, School of Mechanical Engineering, VIT
University, Vellore, Tamil Nadu, India Tamil Nadu India
2)Ramesh S
(72)Name of Inventor :
1)Dr. S. Denis Ashok
2)Ramesh S
3)Dr. Shanmukha Nagaraj

(57) Abstract :

ABSTRACT At present, energy consumption is to such an extent that if the same trend goes on then in the future at some point of time, the energy sources will all be exploited. Most of the machines tools in use today utilize a complex hydraulic system to perform the necessary work required for the process. The demand of pressure and flow rate of a hydraulic system varies significantly throughout the cycle. Many older systems are greatly oversized so that they are able to meet the peak hydraulic demand at any point. These systems operate inefficiently because there is typically no way to limit the hydraulic capacity during periods of low demand. Electric motor driven hydraulic systems are commonly employed in Computer Numerically Control (CNC) machine tools for various applications like fixing workpieces on the machine table. The flow requirements for a typical hydraulic clamping system varies during machining of components, however, the existing electric motor drives operate at the constant speed and it leads to increased electrical power consumption. Energy conservation in a hydraulic power pack refers to the reduction in the energy consumed by the power pack. Many experiments have been conducted to reduce the energy consumption and various approaches such as a concept of regeneration and variable frequency drive have been introduced. The present work deals with an energy conservation strategy by retrofitting a Variable Frequency Drive (VFD) in the motor drive of the hydraulic system in a CNC machine for varying the speed of the motor at different load conditions. The prospective VFD based hydraulic pumping system was compared with the existing hydraulic pumping circuit. The comparison was based on the power consumed, rise in temperature, noise levels, and flow of oil through pressure relief valve, total oil flow during the loading cycle. By comparing both the circuits, it was found that for the prospective system, consumption of power reduces by 78.4%.

No. of Pages : 9 No. of Claims : 4

(54) Title of the invention : A NOVEL SMART THERMOELECTRIC PELTIER MODULE BASED GAS STOVE

(51) International :F25B0021020000,F24C0003120000,F24C0015100000,F23N0005240000,F24C0003140000 classification
(31) Priority Document :NA
No
(32) Priority Date :NA
(33) Name of priority country :NA
(86) International Application No :NA
Filing Date
(87) International Publication No :NA
(61) Patent of Addition to Application Number :NA
Filing Date
(62) Divisional to Application Number :NA
Filing Date

(71)Name of Applicant :
1)Adithya Ballaji
Address of Applicant :Adithya Ballaji, School of EEE, Rukmini knowledge park, REVA University Kattegenahalli Bangalore-560064 Karnataka India Karnataka India
2)Sujo Oommen
3)Rajashekar P Mandi
4)Sujan Ajay Hosahallimatha
5)Sanjoy Goldin Dsouza
(72)Name of Inventor :
1)Adithya Ballaji
2)Sujo Oommen
3)Rajashekar P Mandi
4)Sujan Ajay Hosahallimatha
5)Sanjoy Goldin Dsouza

(57) Abstract :

The heat from the flame of a burner in the gas stove is a source of energy. Here only the upper part comes in contact with the vessel while the rest of heat from the flame is left unused. As the technology progresses new and innovative cooking methods have been developed. But still there is much bigger void to fill in areas of safety and efficient use of LPG. Here a novel smart thermoelectric Peltier module based gas stove with a fuel leakage detector and control, along with self energy generation using thermoelectric Peltier module has been developed. A total of 8 thermoelectric Peltier module unit is installed on two burners with 4 modules each. As can be seen in the Fig. 1 below, Hot side of the module is attached to the aluminum heat absorbing plate just in case to control the temperature and the cold side to heat sink . The module generates the electricity when the burner is ON and flames heats the hot side with aluminum plate. Then the module is connected to a power converter and is used for charging the battery and can further be used to supply for loads like TV, Fan and Lighting. The other system takes care of safety and efficiency of LPG use, a smart technology is developed which helps in detecting the leakage in gas, there by switching off the regulator immediately and sending the notification to the user along with rising the alarm to notify the person absent as shown in Fig. 2 Whenever any vessel is removed the burner is automatically switched off thereby saving the fuel. In case of failure in switching off the regulator, a secondary control from the mobile can be initiated. Thus together this invention proposes a safe, efficient, smart and self sustainable cooking gas stove using thermoelectric Peltier and smart technology.

No. of Pages : 6 No. of Claims : 5

(12) PATENT APPLICATION PUBLICATION

(21) Application
No.201941042063 A

(19) INDIA

(22) Date of filing of Application :17/10/2019

(43) Publication Date :
20/12/2019

(54) Title of the invention : VIDEO PLAYBACK WITH AD STACK ACTION BAR FUNCTIONALITY

(51)
International :H04N0021472000,G06F0003048800,H04N0021410000,H04N0021810000,H04N0021658000
classification
(31) Priority
Document :NA
No
(32) Priority :NA
Date
(33) Name
of priority :NA
country
(86)
International
Application :NA
No :NA
Filing
Date
(87)
International : NA
Publication
No
(61) Patent
of Addition
to
Application :NA
Number :NA
Filing
Date
(62)
Divisional to
Application :NA
Number :NA
Filing
Date

(71)Name of Applicant
:
1)Mr. M. SELVAM
Address of
Applicant :38, Bhavai
Street, Annai Indira
Nagar, West
Thambaram, Chennai-
600 045, Tamil Nadu,
India Tamil Nadu India
2)Mr. A. RAMESH
(72)Name of Inventor :
1)Mr. M. SELVAM
2)Mr. A. RAMESH

(57) Abstract :

A method for video playback includes displaying a video on a screen, detecting a ad stack request, pausing the video and displaying a stack images including at least one active dose icon. In an example embodiment, In each section of ad stack includes an call to action providing actions such as playing a new video in a new window, hyperlinking to a website, interacting with social media, etc. In a further example embodiment, the display of the ad stack option provides the list of related videos ad content in a multi-screen option and the user can select the video from list. Adstack provide the control to the user to either choose a new video or to continue the existing advertisement.

No. of Pages : 13 No. of Claims : 5

(12) PATENT APPLICATION PUBLICATION

(21) Application
No.201941044512 A

(19) INDIA

(22) Date of filing of Application :03/11/2019

(43) Publication Date :
20/12/2019

(54) Title of the invention : A SYSTEM AND METHOD FOR IMPLEMENTING A PERSISTENT DATA STRUCTURE IN A DECENTRALIZED CURRENCY SYSTEM

(51)
International :G06Q0020060000,G06Q0020380000,G06Q0020400000,B60T0008170000,H04M0001656000
classification
(31) Priority
Document :NA
No
(32) Priority :NA
Date
(33) Name
of priority :NA
country
(86)
International
Application :NA
No :NA
Filing
Date
(87)
International : NA
Publication
No
(61) Patent
of Addition
to
Application :NA
Number :NA
Filing
Date
(62)
Divisional to
Application :NA
Number :NA
Filing
Date

(71)**Name of Applicant**
:
1)PES University
Address of
Applicant :100 Feet
Ring Road,
Banashankari 3rd stage,
Bangalore Karnataka
India
(72)**Name of Inventor**
:
1)Shreekanth
Mooroor Prabhu
2)Shreya
Padukasahasram
Krishnan
3)Brindavana
Sachidanand

(57) Abstract :

A system and method for implementing a persistent data structure in a decentralized currency system [0028] The present invention relates to a system (100) and method (200) for implementing a persistent data structure in a decentralized currency system. The method (200) comprises the steps of enrolling one or more end-customers by designated personnel for engaging in a digital transaction thereby transmitting the digital currency to the end-customer by the designated personnel. The designated personnel validates one or more end-customers prior to the initiation of transaction and validates the digital currency encompassed by the end-customer to ensure the flow of currency is authentic. A persistent data structure is generated amongst at least two end-customers which is updated upon the initiation of the transaction amongst fellow end-customers. Further, the transaction initiated amongst at least two end-customers is assessed by a central authority for validating the transaction amongst fellow end-customers. (Figure 1)

No. of Pages : 16 No. of Claims : 10

(12) PATENT APPLICATION PUBLICATION

(21) Application
No.201941047469 A

(19) INDIA

(22) Date of filing of Application :21/11/2019

(43) Publication Date :
20/12/2019

(54) Title of the invention : AERODYNAMIC WING STRUCTURE

(51)
International :B64C0003180000,G06F0017500000,B64C0005020000,B64C0003200000,B64C0003560000
classification
(31) Priority
Document :NA
No
(32) Priority :NA
Date
(33) Name
of priority :NA
country
(86)
International
Application :NA
No :NA
Filing
Date
(87)
International
Publication : NA
No
(61) Patent
of Addition
to
Application :NA
Number :NA
Filing
Date
(62)
Divisional to
Application :NA
Number :NA
Filing
Date

(71)**Name of Applicant :**
1)Sadu Rajeev Reddy
Address of Applicant
:H.No - 1-70,
Chintalchanda Village,
Laxmanchanda Mandal,
Nirmal District,
Telangana-504310.
Telangana India
(72)**Name of Inventor :**
1)Sadu Rajeev Reddy

(57) Abstract :

TITLE: AERODYNAMIC WING STRUCTURE 7. Abstract The present invention pertains to the design of an aerodynamic wing structure with an improved design of model structural design (100) of the basic vortex wing with various structural elements comprising a front spar (156) and rear spar (157) to carry the load experienced by the wing structure, stringers (158), ribs (154) to hold and carry all the structural components of the wing, torsion box to store and reserve fuel, a smooth secondary skin (155) (thin plates) to redistribute the repeated aerodynamic loads uniformly to other structural elements, a plurality of ball/cylindrical bearings driven shafts placed on the circular slotted ribs on both upper & lower surfaces of the ribs and a leading edge powered shaft (150) and trailing edge shaft (152). Further the additional design like supersonic wing structure (800) and inverse folding wing (1100) are also disclosed. Figure related to abstract is FIG. 1.

No. of Pages : 24 No. of Claims : 17

(12) PATENT APPLICATION PUBLICATION

(21) Application
No.201941047690 A

(19) INDIA

(22) Date of filing of Application :22/11/2019

(43) Publication Date :
20/12/2019

(54) Title of the invention : AN AUTOMATED SYSTEM FOR SANITIZING A PRE-DEFINED VICINITY

(51)
International :G01N0035000000,D06F0058280000,B60R0021010000,B08B0009032000,D06F0058220000
classification
(31) Priority
Document :NA
No
(32) Priority :NA
Date
(33) Name
of priority :NA
country
(86)
International
Application :NA
No :NA
Filing
Date
(87)
International : NA
Publication
No
(61) Patent
of Addition
to
Application :NA
Number :NA
Filing
Date
(62)
Divisional to
Application :NA
Number :NA
Filing
Date

(71)**Name of Applicant :**
1)Vellore Institute of Technology
Address of Applicant
:Vellore Institute of
Technology, Near
Katpadi Road, Vellore
Tamil Nadu India
(72)**Name of Inventor :**
1)Dr. Arivazhagan Natarajan
2)Mr. Harsh Umang
3)Mr. Harshal Tikare
4)Mr. Madhukumar S

(57) Abstract :

An automated system for sanitizing a pre-defined vicinity [0030] The present invention relates to an automated system (100) for sanitizing a pre-defined vicinity. The system (100) comprises one or more sensor units (101) for detecting the presence of debris in a pre-defined vicinity, wherein the sensor units (101) transmit signals to a control unit (102) which analyzes the signals and generates an output signal which is transmitted to a driving unit (104). The driving unit (104) drives an automated cleaning unit (105) for sanitizing a pre-defined vicinity, wherein the automated cleaning unit (105) flushes away the debris accumulated in the pre-defined vicinity. Further, the system (100) comprises a moisture detector unit (103) to detect whether the pre-defined vicinity is cleansed or left uncleaned, wherein the moisture detector unit (103) notifies the control unit (102) in case the pre-defined vicinity is cleansed, thereby preventing the replication of cleansing operation. (Figure 1)

No. of Pages : 16 No. of Claims : 6

(12) PATENT APPLICATION PUBLICATION

(21) Application
No.201941047691 A

(19) INDIA

(22) Date of filing of Application :22/11/2019

(43) Publication Date :
20/12/2019

(54) Title of the invention : A FLYING OBJECT FOR DISPENSING CHEMICAL COMPOSITION AND METHOD THEREOF

(51)
International :B64C0039020000,G06N0020000000,A01C0021000000,A01M0007000000,G05D0001000000
classification
(31) Priority
Document :NA
No
(32) Priority :NA
Date
(33) Name
of priority :NA
country
(86)
International
Application :NA
No :NA
Filing
Date
(87)
International
Publication : NA
No
(61) Patent
of Addition
to
Application :NA
Number :NA
Filing
Date
(62)
Divisional to
Application :NA
Number :NA
Filing
Date

(71)**Name of Applicant**
:
1)PES University
Address of
Applicant :100 Feet
Ring Road,
Banashankari III Stage,
Bengaluru 560076,
Karnataka, India
Karnataka India
(72)**Name of Inventor**
:
1)Mr. Dhanush Ravi
2)Mr. Chirag Natesh
Vijay
3)Mr. Antony Louis
Piriyakumar Douglas

(57) Abstract :

A FLYING OBJECT FOR DISPENSING CHEMICAL COMPOSITION AND METHOD THEREOF [0047] Industrial fertilizer and pesticides used in agriculture have major health concerns and farmers are advised to administer chemicals minimally. The present invention dispenses chemical compositions using sensor data and drones. A flight path is normally assigned to the flying object (100) to cover the field. As the flying object (100) takes off for flying on designated path (118), it senses (102) the disease by capturing an image with sensor (150). Using the data, the computing system (106) detects the disease based on machine learning models. If the disease is detected, the actuating means (105) actuates the control unit (116) which is an on-off controller (103). It opens the dispensing unit (104) to dispense chemical composition (104) only over the diseased vegetation. The spread of the disease (128) can be modelled and prevented using drones. (Figure 1)

No. of Pages : 24 No. of Claims : 13

(12) PATENT APPLICATION PUBLICATION

(21) Application
No.201941047692 A

(19) INDIA

(22) Date of filing of Application :22/11/2019

(43) Publication Date :
20/12/2019

(54) Title of the invention : A SYSTEM AND METHOD FOR REAL-TIME CORRECTION OF COLLUSION-FREE FLIGHT PATHS OF FLYING OBJECTS

(51)
International :B64C0039020000,G08G0005000000,G05D0001100000,G08G0005040000,G01S0019140000
classification
(31) Priority
Document :NA
No
(32) Priority :NA
Date
(33) Name
of priority :NA
country
(86)
International
Application :NA
No :NA
Filing
Date
(87)
International : NA
Publication
No
(61) Patent
of Addition
to
Application :NA
Number :NA
Filing
Date
(62)
Divisional to
Application :NA
Number :NA
Filing
Date

(71)**Name of Applicant**
:
1)PES University
Address of
Applicant :100 Feet
Ring Road,
Banashankari III Stage,
Bengaluru 560076.
Karnataka, India
Karnataka India
(72)**Name of Inventor :**
1)Mr. Devashish
Satyanarayan
Vaishnav
2)Mr. Vivek Partal
3)Mr. Yashas
Nagavane Dattatreya
4)Mr. Antony Louis
Piriyakumar Douglas

(57) Abstract :

A SYSTEM AND METHOD FOR REAL-TIME CORRECTION OF COLLUSION-FREE FLIGHT PATHS OF FLYING OBJECTS [0038] In the modern era of technology, it is essential for real-time correction of collusion-free flight paths of flying objects (101), particularly for correcting the flight paths whenever deviation occurred among drones. It is required to fly the drone in predefined flight path, transmit the location information (123) from GPS unit (103) of each drone to master control processor (107), compute (124) the deviation (108) in current position of flying objects (101), derive flight parameters (125) for each drone based on the deviation and the location information received by the master control processor (107), send the flight parameters (126) to respective drones and guide (127) the flying object (101). The deviation (108) is computed to ensure collision free operations using information from GPS module (103) and sensing means (102) operably coupled with the flying objects (101). (Figure 1)

No. of Pages : 22 No. of Claims : 10

(12) PATENT APPLICATION PUBLICATION

(21) Application
No.201941047694 A

(19) INDIA

(22) Date of filing of Application :22/11/2019

(43) Publication Date :
20/12/2019

(54) Title of the invention : A FLYING SYSTEM FOR DETECTING A SOURCE OF GAS LEAKAGE AND METHOD THEREOF

<p>(51) International :G01N0021390000,B64C0039020000,G01M0003220000,G08G0005000000,G01M0003200000 classification (31) Priority Document :NA No (32) Priority Date :NA (33) Name of priority :NA country (86) International Application :NA No :NA Filing Date (87) International Publication : NA No (61) Patent of Addition to Application :NA Number :NA Filing Date (62) Divisional to Application :NA Number :NA Filing Date</p>	<p>(71)Name of Applicant : 1)PES University Address of Applicant :100 Feet Ring Road, Banashankari III Stage, Bengaluru 560076, Karnataka, India Karnataka India (72)Name of Inventor : 1)Mr. Shreyas Sridhar 2)Mr. Shubham Mathur 3)Ms. Siri Prasad 4)Mr. Antony Louis Piriyakumar Douglas</p>
--	---

(57) Abstract :

A FLYING SYSTEM FOR DETECTING A SOURCE OF GAS LEAKAGE AND METHOD THEREOF [0040] To minimize waste of gas leaked which also results in the loss of billions of dollars, to detect a source of gas leakage using sensor data, particularly for detecting a source of gas leakage in a gas pipeline or in industry environments with the sensor data using drones (700) is essential. The steps include to collect sensor data (2200), processes the sensor data, find the location of the source of gas leakage (610) and stop the gas leakage (2700) using drones. The potential field method (2310) is used to locate the source of gas leakage (2000) which can be computed onboard in drones with sensors such as vision camera, thermal, IR (infrared), UV (ultraviolet) camera along with TDL (tunable diode laser) sensors and other chemical sensors. Upon locating the source of gas leakage, the system (1000) will deploy a mechanism to stop gas leakage (2700). Also, multiple drones are used such that each has non colliding flight paths and each communicate to others sharing the geotagged locations along with information about the extent of gas leakage to jointly find the source of gas leakage quickly. (Figure 1)

No. of Pages : 24 No. of Claims : 16

(12) PATENT APPLICATION PUBLICATION

(21) Application
No.201941047695 A

(19) INDIA

(22) Date of filing of Application :22/11/2019

(43) Publication Date :
20/12/2019

(54) Title of the invention : A SYSTEM AND METHOD FOR RUNTIME MODIFICATION OF CONSTELLATION OF FLYING OBJECTS IN MIDAIR

(51)
International :B64C0039020000,G08G0005000000,G05D0001100000,G05D0001040000,B64D0047080000
classification
(31) Priority
Document :NA
No
(32) Priority :NA
Date
(33) Name
of priority :NA
country
(86)
International
Application :NA
No :NA
Filing
Date
(87)
International : NA
Publication
No
(61) Patent
of Addition
to
Application :NA
Number :NA
Filing
Date
(62)
Divisional to
Application :NA
Number :NA
Filing
Date

(71)Name of Applicant
:
1)PES University
Address of
Applicant :100 Feet
Ring Road,
Banashankari III Stage,
Bengaluru 560076.
Karnataka, India
Karnataka India
(72)Name of Inventor :
**1)Mr. Jeevan
Shridhar Devagiri**
**2)Mr. Parthan
Manisekaran**
**3)Mr. Antony Louis
Piriyakumar Douglas**

(57) Abstract :

Drones (UAVs) are used to perform variety of operations. Enhancing payload (119) capacity which is currently a limiting factor, new design of drone is essential. Constellation (101) of drones forming an optimal constellation (101) can together perform variety of tasks at runtime in mid-air. Steps to achieve include flying the drones, transmitting (117) location information from GPS module (104) of each drone, choosing (111) subset of drone, deriving (113) flight parameters for each drone, sending flight parameters to respective drones, guiding (115) the drones towards the desired location using the flight parameters, and energizing (116) electromagnetic pads (103) of subset of drones according to constellation (101) of drones for attaching with respective drones with designated master control processor (112). For attaching or detaching in the mid-air, electromagnetic pads (103) are used. (Figure 1)

No. of Pages : 23 No. of Claims : 12

(12) PATENT APPLICATION PUBLICATION

(21) Application
No.201941048807 A

(19) INDIA

(22) Date of filing of Application :28/11/2019

(43) Publication Date :
20/12/2019

(54) Title of the invention : A VERTICAL AXIS WIND TURBINE WITH MODIFIED BLADE STRUCTURE

(51)
International :F03D0003060000,F03D0003000000,F03D0003040000,F03D0003020000,F03D0013200000
classification
(31) Priority
Document :NA
No
(32) Priority :NA
Date
(33) Name
of priority :NA
country
(86)
International
Application :NA
No :NA
Filing
Date
(87)
International : NA
Publication
No
(61) Patent
of Addition
to
Application :NA
Number :NA
Filing
Date
(62)
Divisional to
Application :NA
Number :NA
Filing
Date

(71)Name of Applicant :
**1)Vel Tech
Rangarajan Dr.
Sagunthala R&D
Institute of Science and
Technology**
Address of Applicant
:No.42, Avadi Vel Tech
Road, Avadi, Chennai -
600 062 Tamil Nadu,
India Tamil Nadu India
(72)Name of Inventor :
**1)Mr. M. Bharath
2)Dr. J. Logeshwari
3)Mr. M. S.
Harikrishnan**

(57) Abstract :

A VERTICAL AXIS WIND TURBINE WITH MODIFIED BLADE STRUCTURE A vertical axis wind turbine with modified blade structure, that is to increase the efficiency of smaller size VAWT (Vertical Axis Wind Turbine), some notable changes in vanes are proposed by using the concepts of flow through nozzle. Boomerang shaped blades with holes in inner face and opening in the outer edge creates a controlled volume space for the flow of wind. This controlled volume will control the air follow and the air is expelled via outer edge of the blades can increase the whirl velocity of the blades and contributes to the increases in the efficiency of blades. Most illustrative figure is Fig.1

No. of Pages : 8 No. of Claims : 3

(12) PATENT APPLICATION PUBLICATION

(21) Application
No.201941048981 A

(19) INDIA

(22) Date of filing of Application :28/11/2019

(43) Publication Date :
20/12/2019

(54) Title of the invention : WEATHER PARAMETER AND POLLUTION LEVEL EXTRACTION USING IOT FOR VARIOUS TRAFFIC NODAL POINTS WITH SOLAR CHARGING

<p>(51) International :G01W0001000000,G01S0013950000,G01W0001100000,G08B0021180000,G06Q0050260000 classification (31) Priority Document :NA No (32) Priority :NA Date (33) Name of priority :NA country (86) International Application :NA No :NA Filing Date (87) International : NA Publication No (61) Patent of Addition to Application :NA Number :NA Filing Date (62) Divisional to Application :NA Number :NA Filing Date</p>	<p>(71)Name of Applicant : 1)Pratyush Kumar Panda Address of Applicant :School of Electrical and Electronics Engineering, REVA University,Rukmini Knowledge Park, Kattigenahalli, Yelahanka, Bengaluru, Karnataka 560064, India Karnataka India 2)Adithya Ballaji 3)Sujo Oommen 4)Dr. Rajashekar P Mandi 5)Manish Bharat (72)Name of Inventor : 1)Pratyush Kumar Panda 2)Adithya Ballaji 3)Sujo Oommen 4)Dr. Rajashekar P Mandi 5)Manish Bharat 6)Mahesh Kumar 7)Sagar B S</p>
--	--

(57) Abstract :

Climate change is real and it's™s happening. In the recent times there has been drastic change in weather conditions. Along with the ongoing climate change, pollution level has also been on the rise in various places. Thus it has become a very necessity to track the weather and pollution level parameters. The proposed system presents an advanced and smart method of weather and pollution level parameter extraction using IoT for various traffic nodal points with solar charging. The system is developed using an intelligent algorithm which helps in the real time extraction of the weather and pollution level parameters. The weather data which are extracted in real time is displayed on the system screen for human interface, transferred to public domain website and finally sent to meteorological Department for analysis. The system is divided into four parts Power supply unit, Central Processor, Sensing Unit and Broadcasting Unit. It analysis the data collected using the predefined parameter in the algorithm and sounds the alarm in emergency situations.

No. of Pages : 13 No. of Claims : 7

(12) PATENT APPLICATION PUBLICATION

(21) Application
No.201941049388 A

(19) INDIA

(22) Date of filing of Application :02/12/2019

(43) Publication Date :
20/12/2019

(54) Title of the invention : SHAPE MODIFICATION OF ELLIPTICAL CYLINDERS FOR EFFECTIVE THERMAL AND HYDRAULIC PERFORMANCE

(51)
International :B23K0001000000,C09K0005000000,B32B0015000000,C22C0019030000,B23P0015260000
classification

(31) Priority
Document :NA
No

(32) Priority :NA
Date

(33) Name
of priority :NA
country

(86)
International
Application :NA
No :NA

Filing
Date

(87)
International : NA
Publication
No

(61) Patent
of Addition
to
Application :NA
Number :NA
Filing

Date

(62)
Divisional to
Application :NA
Number :NA
Filing

Date

(71)**Name of Applicant :**
**1)Dr.R.Senthil
Kumar**

Address of Applicant
:Research Assistant
Professor, Department of
Mechanical Engineering,
SRM Institute of Science
and Technogy, SRM
Nagar, Kattankulathur,
Chennai-603203, Tamil
Nadu, India. Tamil Nadu
India

(72)**Name of Inventor :**
**1)Dr.R.Senthil
Kumar**
2)Ashwin Mahendra

(57) Abstract :

ABSTRACT SHAPE MODIFICATION OF ELLIPTICAL CYLINDERS FOR EFFECTIVE THERMAL AND HYDRAULIC PERFORMANCE The present disclosure relates to components and tubes used in various industrial and domestic equipment such as electronic components (capacitors, resistors, transducers. ICS. etc.), tubes in condensers and evaporators in air conditioning systems, heat exchangers in thermal power stations, radiators in automobiles; etc. Elliptical cylinders have been in wide use in these fields due to their lesser resistance to How and pressure drop as compared to circular cylinders. The new design described in the disclosure reveals a relocation of the minor axis on major axis without altering the projected length to optimize the outer geometry. The new design provides lesser flow resistance and better heat dissipation compared to traditionally existing elliptical cylinders.

No. of Pages : 6 No. of Claims : 4

(12) PATENT APPLICATION PUBLICATION

(21) Application No.201941049389
A

(19) INDIA

(22) Date of filing of Application :02/12/2019

(43) Publication Date : 20/12/2019

(54) Title of the invention : MEMORY ARCHITECTURING BASED ON DESIGN OF DOMAIN WALL MEMORY TECHNIQUE

(51)
International :G11C0019080000,B82Y0010000000,G06F0016000000,B01J0023755000,G06F0009500000
classification
(31) Priority
Document :NA
No
(32) Priority :NA
Date
(33) Name
of priority :NA
country
(86)
International
Application :NA
No :NA
Filing
Date
(87)
International : NA
Publication
No
(61) Patent
of Addition
to :NA
Application :NA
Number :NA
Filing
Date
(62)
Divisional to
Application :NA
Number :NA
Filing
Date

(71)Name of Applicant :
1)Dr.S. SREEKANTH
Address of Applicant :Sreenivasa
Instiute Of Technology And
Management Studies(autonomous),
,Murukambattu(Post),Chittoor(Dist),
Andhra Pradesh-517127 Andhra Pradesh
India
2)Dr.S.THULASEEKRISHNA
3)Dr.P.DHANA LAKSHMI
4)A.N. SREEDHAR
5)MERUVA SREENIVASULU
6)S.SHIVA PRAKASH
7)HEMAJOTHI SELWYN
DAODARAN
(72)Name of Inventor :
1)Dr.S. SREEKANTH
2)Dr.S.THULASEEKRISHNA
3)Dr.P.DHANA LAKSHMI
4)A.N. SREEDHAR
5)MERUVA SREENIVASULU
6)S.SHIVA PRAKASH
7)HEMAJOTHI SELWYN
DAODARAN

(57) Abstract :

Recent trend in technology is the field of Internet of Things (IoT) which connects gigantically large number of devices, where each device generates huge amount of data which need processing, storage and retrieval whenever required. The memory for storing the data and for processing is large. The major power consumption is by the memory device which has become the principal contributor adding constraint in developing the design of main memory for conventional applications such as IoT and big data. As IoT involves connection of nodes that are at remote distance, the data to be stored also increases with the number of nodes involved. More the number of nodes, more the requirement of memory for storage. Higher requirement of energy provides higher efficiency meeting the higher capacity need of IoT. In this invention the conventional memory is replaced by domain wall memory (DWM), emerging technology of non-volatile memory is proposed which are promising to provide ultra high density. Domain wall memory (DWM) is used in designing the architecture of CPU, GPU and processors that are application specific.

No. of Pages : 10 No. of Claims : 6

(12) PATENT APPLICATION PUBLICATION

(21) Application
No.201941049396 A

(19) INDIA

(22) Date of filing of Application :02/12/2019

(43) Publication Date :
20/12/2019

(54) Title of the invention : WIRELESS HUMANOID BIONIC ARM ON ROBOTIC VEHICLE

(51)
International :B25J0009160000,B25J0011000000,B25J0009000000,H04W0084040000,B25J0013000000
classification
(31) Priority
Document :NA
No
(32) Priority :NA
Date
(33) Name
of priority :NA
country
(86)
International
Application :NA
No :NA
Filing
Date
(87)
International
Publication : NA
No
(61) Patent
of Addition
to
Application :NA
Number :NA
Filing
Date
(62)
Divisional to
Application :NA
Number :NA
Filing
Date

(71)Name of Applicant :
**1)BHARATH
INSTITUTE OF
HIGHER EDUCATION
AND RESEARCH**
Address of Applicant
:173, Agharam Road,
Selaiyur, Chennai 600 073
Tamil Nadu India
(72)Name of Inventor :
**1)G. Hemavathy
2)K. Venkateshwari
3)S. Sherine
4)S. Aarthi Suriya**

(57) Abstract :

ABSTRACT Wireless Humanoid Bionic Arm on Robotic Vehicle This invention is related to robot technology which is used to work without using of manpower. This robotic system has two wireless controllers mounted on gloves, one for each hand of the operator. This micro controller is used to control the movement of the robot arm. Here the sensor recognizes the movement of gloves and gives information to the micro controller. Robotic arm will operate based on the given code. This is used for industries to reduce the human risk while dealing with high temperature components and also for commercial application as human assistance.

No. of Pages : 7 No. of Claims : 1

(12) PATENT APPLICATION PUBLICATION

(21) Application
No.201941049403 A

(19) INDIA

(22) Date of filing of Application :02/12/2019

(43) Publication Date :
20/12/2019

(54) Title of the invention : STEP PATH LIGHT OR STAIRCASE LIGHT FOR NIGHT

(51)
International :H05B0037020000,H05B0033080000,G06T0007246000,G05B0019414000,F21K0009200000
classification
(31) Priority
Document :NA
No
(32) Priority :NA
Date
(33) Name
of priority :NA
country
(86)
International
Application :NA
No :NA
Filing
Date
(87)
International : NA
Publication
No
(61) Patent
of Addition
to
Application :NA
Number :NA
Filing
Date
(62)
Divisional to
Application :NA
Number :NA
Filing
Date

(71)Name of Applicant
:
**1)BHARATH
INSTITUTE OF
HIGHER
EDUCATION AND
RESEARCH**
Address of Applicant
:173, Agharam Road,
Selaiyur, Chennai 600
073 Tamil Nadu India
(72)Name of Inventor :
**1)Dr. S. Philomina
2)Dr. M. Jasmin
3)K. Subbulakshmi
4)S. Saravana**

(57) Abstract :

ABSTRACT Step path light or staircase light for night This invention is related to the sensor technology. Sensor is a device that can represent aspects of the physical world as data in real time. Here the motion dependent sensor is used. The summarization of all the input/output of sensors and lighting control technology given an outcome that sensors output are mostly either in analog or digital, while the input for control lighting are mostly in pulses or pulse width modulation (PWM). The development of MICS is to integrate each of the sensors and lighting control system into different modules. Each of the modules connected to one management console that acts as the main processor of the whole systems. Furthermore, the modular design approaches applied to MICS design, thus, any additional sensors or lighting module can be easily added to the whole system which is an important scalability feature. MICS is divided into two modules: Input module and Light module. Input module receives the sensor signal while light module controls the lighting system.

No. of Pages : 8 No. of Claims : 2

(54) Title of the invention : A NOVEL SECURE ARCHITECTURE MODEL FOR SMART AND USER-FRIENDLY BANKING SYSTEM

(51) International :H04L0029060000,G06Q0020380000,G06Q0020400000,G06Q0020340000,G06Q0020320000 classification
 (31) Priority Document :NA
 No
 (32) Priority :NA
 Date
 (33) Name of priority :NA
 country
 (86) International Application :NA
 No :NA
 Filing Date
 (87) International Publication : NA
 No
 (61) Patent of Addition to Application :NA
 Number :NA
 Filing Date
 (62) Divisional to Application :NA
 Number :NA
 Filing Date

(71)Name of Applicant :
1)Dr. Ashok Kumar Pradhan
 Address of Applicant :Department of Computer Science and Engineering, SRM University, AP, Neerukonda, Mangalagiri, Pin: 522503 Andhra Pradesh India
2)Mr. Bhaskara Santosh
3)Dr. Sandeep Saxena
4)Dr.S.Balamurugan
5)Dr. Rajiv Kumar
6)Mr. Gaurav Kumar Rajput
7)Dr. Vimal Kumar
 (72)Name of Inventor :
1)Dr. Ashok Kumar Pradhan
2)Mr. Bhaskara Santosh
3)Dr. Sandeep Saxena
4)Dr.S.Balamurugan
5)Dr. Rajiv Kumar
6)Mr. Gaurav Kumar Rajput
7)Dr. Vimal Kumar

(57) Abstract :

This invention highlights a novel architecture for banking and financial sectors, which is designed to provide easy and user-friendly smart banking along with robust security against real-time attacks. The proposed system uses a mechanism to detect and alerts the bankers about financial frauds by using unique user identification number (UUIIN) at the time of bank account creation. The transactions validation server in private blockchain identify and stops the financial frauds like issuing loans from different banks against same property using UUIIN. This system uses multifactor authentication (MA) mechanism for verifying the identity and authorization of a user/device to provide defense against unauthorized transactions and identity theft attacks. The combination of authentication server cluster (ASC) and banking application controls and monitors the credit transactions. A special module of artificial intelligence (AI)/ machine learning (ML) enhance the capability of IDS/IPS to provide best level security at gateways. The AI/ML powered IDS/IPS can eliminate the known attacks before they enter into the private space. Additionally, it updates detection rules based on the logs generated from the honeypots network (HN) traffic, which gives the ability to detect future threats. The proposed system uses two levels of load balancers (LB) to accomplish two different tasks. The first level of LB contains AI/ML powered IDS/IPS and at the second level a pure LB, which distributes the client's request load in even form to banker's server nodes. This system uses a quiz gaming concept (GC), which is used to provide virtual automated teller machine (ATM) a personal identification number (PIN) and authorization for the user to do successful transaction. This GC intended to eliminate the frequent usage of physical cards and ATM pins, which protects them from the public visibility to avoid misuse. To provide a high level of authentication, the proposed system uses biometric authentication instead of a physical card at ATM level. This system provides cloud computing like resource clusters to share and utilize common infrastructure among different banks which provides an easy way to upgrade banks working capability without affecting its normal functionality. The user end device verification is done before they start transactions using the mobile application. The verification is done through another verified device where the detail of user and devices information is used to generate activation code (AC). The combination of the AC and OTP verifies the user identity and allows the user to perform transactions. The proposed system has AI/ML customer interactive module to send recommendations based on user recent activities. The system covers the confidentiality, integrity, availability (CIA) triad in digital security by using above said technologies and mechanisms. Simultaneously, all communications are encrypted end to end with post quantum cryptographic algorithms.

No. of Pages : 11 No. of Claims : 7

(12) PATENT APPLICATION PUBLICATION

(21) Application
No.201941049461 A

(19) INDIA

(22) Date of filing of Application :02/12/2019

(43) Publication Date :
20/12/2019

(54) Title of the invention : VIRTUAL REALITY BASED WIRELESS RESCUE ROBOT AND A METHOD TO RESCUE CHILD FALLEN INTO DEEP WELL

(51)
International:G08B0021020000,B60N0002280000,E06B0001600000,A62B0035000000,F26B0025180
classification 000
n
(31) Priority
Document :NA
No
(32) Priority :NA
Date
(33) Name
of priority :NA
country
(86)
International
Application :NA
No :NA
Filing
Date
(87)
International
Publication : NA
No
(61) Patent
of Addition
to
Application :NA
Number :NA
Filing
Date
(62)
Divisional
to
Application :NA
Number :NA
Filing
Date

(71)Name of Applicant :
1)ARIVAZHAGAN S
Address of Applicant
:11/1 ARCHUNAN SALAI,
GOVINDASAMY NAGAR,
AHABATHARANAPURA
M VADALUR,
CUDDALORE DISTRICT-
607 303 Tamil Nadu India
2)G.SUGANYA
PRIYADHARSHINI
(72)Name of Inventor :
1)ARIVAZHAGAN S
2)G.SUGANYA
PRIYADHARSHINI
3)VAIRA VIGNESH.R
4)VELMURUGAN.T
5)MAKESHKUMAR.M

(57) Abstract :

A virtual reality-based wireless rescue robot and a method to rescue the child fallen into deep well comprises of two main embodiments. The first embodiment comprises two identical arms to grasp the child and an extendable links are used to cling the device firmly to the walls of the deep bore well. A night vision camera fixed in the device helps the rescuer to control the two identical arms with wireless 10 channel radio. The VTX (video transmitter) fixed in the device sends the live video wirelessly to the rescuer VR goggles. The second embodiment comprises of cylindrical shaped flexible plastic bag with the closing mechanism at the bottom end of the embodiment. Both first embodiment and second embodiment employs to rescue the trapped child from the deep bore well successfully without any injury.

No. of Pages : 22 No. of Claims : 7

(54) Title of the invention : AN AUTOMATED IOT BASED AGRICULTURE MONITORING SYSTEM WITH PLURALITY OF SENSORS TO DETECT PARAMETERS RELATED THEREOFF

(51) International :A01G0025160000,G06Q0050020000,A01M0007000000,A01G0009240000,A01B0079000000 classification
 (31) Priority Document :NA
 No
 (32) Priority Date :NA
 (33) Name of priority country :NA
 (86) International Application :NA
 No :NA
 Filing Date
 (87) International Publication :NA
 No
 (61) Patent of Addition to Application Number :NA
 Filing Date
 (62) Divisional to Application Number :NA
 Filing Date

(71)Name of Applicant :
1)DR. R. SATHEESH KUMAR
 Address of Applicant :S/O Mr. A. RAJAN
 ASSOCIATE PROFESSOR, DEPARTMENT OF
 COMPUTER SCIENCE AND ENGINEERING,
 SAHRDAYA COLLEGE OF ENGINEERING AND
 TECHNOLOGY, KODAKARA, THRISSUR,
 KERALA, INDIA, PIN-680684 Kerala India
2)DR. D. DAVID NEELS PONKUMAR
3)DR. S.P. VALAN ARASU
4)DR. S. CHIDAMBARANATHAN
5)DR. T. RAMAKRISHNAN
6)MR. CHARLES RAJESH KUMAR. J
7)MR. VINOD KUMAR. D
8)DR. S. RAJ BARATH
9)MRS. G. KEERTHANA
10)MR. R. MAHAVEERAKANNAN
11)DR. S. SILVIA PRISCILA
12)MS. J. UMA
 (72)Name of Inventor :
1)DR. R. SATHEESH KUMAR
2)DR. D. DAVID NEELS PONKUMAR
3)DR. S.P. VALAN ARASU
4)DR. S. CHIDAMBARANATHAN
5)DR. T. RAMAKRISHNAN
6)MR. CHARLES RAJESH KUMAR. J
7)MR. VINOD KUMAR. D
8)DR. S. RAJ BARATH
9)MRS. G. KEERTHANA
10)MR. R. MAHAVEERAKANNAN
11)DR. S. SILVIA PRISCILA
12)MS. J. UMA

(57) Abstract :

An Automated IoT based Agricultural Land Monitoring System with a Plurality of Sensors and Detect Various Parameters related thereto is an invention that will lead to better cultivation practices and Yields. Agriculture depends on various parameters and factors that are artificially created because of current agricultural methods or practices. Soil parameters are the most important factors since no agriculture can be carried out without soil, and it has to be maintained and replenished also. Reducing the amount of water used that is irrigation is the next important factor that has to be monitored since Agriculture mostly depends on monsoon rains that are drastically reduced in recent times. The invention will collect all the related parameters, and the same data will be stored in the centralized server on an hourly basis so that it helps the farmer to get along with an analysis report and plan their cropping accordingly. Thus the invention is advantageous since it reduces cost, water, amount of pesticides required, the number of fertilizers required, in turn helping the farmer to practice a smart agricultural method.

No. of Pages : 25 No. of Claims : 8

(12) PATENT APPLICATION PUBLICATION

(21) Application
No.201941049569 A

(19) INDIA

(22) Date of filing of Application :03/12/2019

(43) Publication Date :
20/12/2019

(54) Title of the invention : A ROBOTIC DEVICE FOR PICKING AND MOVING AN OBJECT AND A METHOD THEREOF

(51)
International :B25J0009160000,G08B0013196000,H04N0005232000,B25J0019020000,G05D0001000000
classification
(31) Priority
Document :NA
No
(32) Priority :NA
Date
(33) Name
of priority :NA
country
(86)
International
Application :NA
No :NA
Filing
Date
(87)
International
Publication : NA
No
(61) Patent
of Addition
to
Application :NA
Number :NA
Filing
Date
(62)
Divisional to
Application :NA
Number :NA
Filing
Date

(71)**Name of Applicant :**
**1)SRM Institute of
Science and Technology**
Address of Applicant
:Kattankulathur, Chennai
Tamil Nadu India
(72)**Name of Inventor :**
**1)C. LIKITH
KUMAR**
2)RAKSHA
3)SHUBANGI
4)BAGESH

(57) Abstract :

The present disclosure discloses a robotic device (100) for assisting a user in picking and moving an object. The device comprises a base (102), a primary arm (104), a secondary arm (106), an end effector (108), a visual sensor arranged in the same sequential manner. The device (100) further comprises a control unit (110) and driving units (112). The visual sensor captures one or more images of a surrounding environment. The control unit (110) cooperates with the visual sensor to receive the captures images and generates a plurality of control signals for driving at least one driving unit (112). The driving units (112) provide movement to the primary arm (104) and the end effector (108), based on said received control signals, to pick up and move the object from its initial position to a final desired position.

No. of Pages : 19 No. of Claims : 10

(12) PATENT APPLICATION PUBLICATION

(21) Application
No.201941049570 A

(19) INDIA

(22) Date of filing of Application :03/12/2019

(43) Publication Date :
20/12/2019

(54) Title of the invention : A SYSTEM FOR GENERATING CAPTIONS FOR VIDEO FRAMES AND A METHOD THEREOF

(51)
International :H04N0021488000,H04N0021440200,G10L0015260000,H04N0021431000,G06K0009000000
classification
(31) Priority
Document :NA
No
(32) Priority :NA
Date
(33) Name
of priority :NA
country
(86)
International
Application :NA
No :NA
Filing
Date
(87)
International : NA
Publication
No
(61) Patent
of Addition
to
Application :NA
Number :NA
Filing
Date
(62)
Divisional to
Application :NA
Number :NA
Filing
Date

(71)Name of Applicant
:
**1)SRM Institute of
Science and
Technology**
Address of
Applicant
:Kattankulathur,
Chennai-603203, Tamil
Nadu, India Tamil Nadu
India
(72)Name of Inventor :
**1)SUPRAJA,
Perumal
2)Ravi Shekhar,
Tiwari**

(57) Abstract :

ABSTRACT A SYSTEM FOR GENERATING CAPTIONS FOR VIDEO FRAMES AND A METHOD THEREOF The present disclosure relates to field of generating captions for video frames. The system for generating captions for video frames comprises a user device (102) and a server (104). The user associated with the user device (102) provide inputs. The server (104) receives the inputs to extract and process the video frames based on the inputs and the first look up table in a repository (106). The server (104) generates at least one vector corresponding to the processed frames and convert each of the vectors to the caption, and is further configured to embed the captions with the corresponding frames. The server (104) transmits the video frames and the caption to the user device (102). The system (100) assist hearing-impaired and visually challenged people to comprehend the video frames.

No. of Pages : 24 No. of Claims : 7

(54) Title of the invention : RECOGNITION OF UNDERWATER BLIND VISION USING ARTIFICIAL INTELLIGENCE

<p>(51) International :G06T0005000000,G06K0009620000,G06K0009000000,G06N0003040000,G06T0005500000 classification (31) Priority Document :NA No (32) Priority :NA Date (33) Name of priority :NA country (86) International Application :NA No :NA Filing Date (87) International : NA Publication No (61) Patent of Addition to :NA Application :NA Number :NA Filing Date (62) Divisional to Application :NA Number :NA Filing Date</p>	<p>(71)Name of Applicant : 1)DR.S.BALAJI Address of Applicant :Asst.Professor ,Department of Computer Science and Engineering Panimalar EngineeringCollege,Chennai-600123 9176982281 Tamil Nadu India 2)DR.N.PUGAZHENDI 3)MR.S.SUBBURAJ 4)MR.M.MOHAN 5)MR.S.A.K JAINULABUDEEN 6)MR. B.S.VIDHYASAGAR 7)MRS.K.PUSHPAVALLI 8)MRS.H.SHALMA (72)Name of Inventor : 1)DR.S.BALAJI 2)DR.N.PUGAZHENDI 3)MR.S.SUBBURAJ 4)MR.M.MOHAN 5)MR.S.A.K JAINULABUDEEN 6)MR. B.S.VIDHYASAGAR 7)MRS.K.PUSHPAVALLI 8)MRS.H.SHALMA</p>
--	--

(57) Abstract :

Abstract: The main challenge in autonomous underwater robotics is image processing, due to light transmission in water. Image restoration technique is used to remove haze in degraded image and also many images are needed from the same location and making impossible to use in real time system. Deep learning technique can be used to overcome other image processing challenges such as detecting object and colorizing image. To dehaze a single image, a convolutional neural network(CNN) will be trained with image restoration technique and it outperforms comparing to other image processing technique. The convolutional neural network addresses the problem present in a underwater scene such as wavelength-dependent light scattering and absorption degrades the visibility of image and this results in low contrast and distorted color. The need of clear underwater image is to study deteriorating aquatic life and coral reefs . The main objective of underwater robotic system relies on high quality images to fulfill the objectives. Due to various factors, the quality of image acquired for some objectives is getting degraded. Example, At a higher rate, red light is absorbed in water than green or blue light. But we see a blue or green color in underwater scene.

No. of Pages : 12 No. of Claims : 7

(12) PATENT APPLICATION PUBLICATION

(21) Application
No.201941049633 A

(19) INDIA

(22) Date of filing of Application :03/12/2019

(43) Publication Date :
20/12/2019

(54) Title of the invention : A METHOD FOR AIDING RESISTIVITY AND ENERGY GAP MEASUREMENT OF SEMICONDUCTORS

(51)
International :C23C0014040000,C23C0030000000,F25D0019000000,B08B0007000000,G01B0021040000
classification
(31) Priority
Document :NA
No
(32) Priority :NA
Date
(33) Name
of priority :NA
country
(86)
International
Application :NA
No :NA
Filing
Date
(87)
International : NA
Publication
No
(61) Patent
of Addition
to
Application :NA
Number :NA
Filing
Date
(62)
Divisional to
Application :NA
Number :NA
Filing
Date

(71)**Name of Applicant :**
**1)SHIVA LINGAPPA
UDACHAN**
Address of Applicant
:H.NO. 4-601/74A/5,
BASAWESHWAR
COLONY EXTN, NEAR
SHIVA MANDIR,
KALABURAGI
Karnataka India
**2)LINGAPPA
ANAVEERAPPA
UDACHAN**
(72)**Name of Inventor :**
**1)SHIVA LINGAPPA
UDACHAN**
**2)LINGAPPA
ANAVEERAPPA
UDACHAN**
**3)SHIVAKUMAR
SIDDANNA
BHAI RAMADAGI**
**4)SHRISHAIL
SHANMUKHAPPA
KOLKUNDI**
**5)NAGESH
SHANMUKHAPPA**
**6)SHANMUKHAPPA
BHARATI**
**7)SIDDANNA
SHWETHA**

(57) Abstract :

The present invention relates to an aiding method and device for four probe method. The level of assistance, not to replace a four point method and the level of assistance is to provide an engaging provision to engage the four points without affecting the surface of the semiconductor. The contacts are taken at four collinear points of the empty/uncoated substrate/semiconductor/testing material with indium or cement along with copper wires (6). A suitable mask is placed on the substrate having copper wire connections. Then this is mounted on the substrate holder and kept in the vacuum chamber. After getting a required vacuum, the deposition of the material takes place on substrate (4) and mask (7). The sample holder along with formed thin film coated state / substrate (10) is taken out of the vacuum chamber (11) and will be ready for electrical measurements.

No. of Pages : 28 No. of Claims : 4

(12) PATENT APPLICATION PUBLICATION

(21) Application
No.201941049665 A

(19) INDIA

(22) Date of filing of Application :03/12/2019

(43) Publication Date :
20/12/2019

(54) Title of the invention : SYSTEM AND COMPUTER IMPLEMENTED METHODS FOR ANALYSING FEATURES OF DIGITAL MEDICAL IMAGES

(51)
International :G06T0007000000,G06T0005000000,G06T0007110000,G06K0009620000,G06T0007900000
classification
(31) Priority
Document :NA
No
(32) Priority :NA
Date
(33) Name
of priority :NA
country
(86)
International
Application :NA
No :NA
Filing
Date
(87)
International : NA
Publication
No
(61) Patent
of Addition
to
Application :NA
Number :NA
Filing
Date
(62)
Divisional to
Application :NA
Number :NA
Filing
Date

(71)Name of Applicant
:
**1)KADIYALA
RAMANA**
Address of Applicant
:Department of CSE,
Annamacharya Institute
of Technology and
Sciences, Rajampet-
516126, Andhra Pradesh,
India Andhra Pradesh
India
**2)Dr. M.RUDRA
KUMAR**
3)Dr. K.PRASANNA
**4)Dr.T.HARI
KRISHNA**
**5)Dr. FAHIMUDDIN
SHAIK**
(72)Name of Inventor :
**1)KADIYALA
RAMANA**
**2)Dr. M.RUDRA
KUMAR**
3)Dr. K.PRASANNA
**4)Dr.T.HARI
KRISHNA**
**5)Dr. FAHIMUDDIN
SHAIK**

(57) Abstract :

Exemplary embodiments of the present disclosure are directed towards a system for analyzing features of digital medical images, comprising: a computing device analyzes underlying problems present in a plurality of digital medical images by a medical image processing and visualization module, the medical image processing and visualization module configured to combine preprocessing techniques and post processing techniques to get an adaptive model of image processing techniques which is used for development of a framework and useful for easy analysis of the plurality of digital medical images; and a database configured to store the plurality of digital medical images, the computing device configured to perform enhancement of the digital medical images by using the medical image processing and visualization module, then performs cell detection segmentation of the plurality of digital medical images, creates a structural element and then dilate and fills the gaps present in the digital medical images to give the perimeter of the cell in binary images. FIG. 1

No. of Pages : 26 No. of Claims : 8

(12) PATENT APPLICATION PUBLICATION

(21) Application
No.201941049770 A

(19) INDIA

(22) Date of filing of Application :03/12/2019

(43) Publication Date :
20/12/2019

(54) Title of the invention : ADAPTABLE BIOMASS COOKING STOVE WITH MOVABLE COMBUSTION CHAMBERS

(51)
International :F24C0005000000,A47J0036360000,F24C0005200000,F24B0003000000,A47J0033000000
classification
(31) Priority
Document :NA
No
(32) Priority
Date :NA
(33) Name
of priority :NA
country
(86)
International
Application :NA
No :NA
Filing
Date
(87)
International
Publication : NA
No
(61) Patent
of Addition
to
Application :NA
Number :NA
Filing
Date
(62)
Divisional to
Application :NA
Number :NA
Filing
Date

(71)Name of Applicant :
1)Dr.Bogala Konda Reddy
Address of Applicant
:Assistant Professor,
Department of Mechanical
Engineering, IIIT RK
Valley, RGUKT,
Vempalli-516330, Kadapa,
Andhra Pradesh, India
Andhra Pradesh India
2)Dr.Alluru Gopala Krishna
3)Nalband Noor Mahammad
4)Korla Mohanakrishna Chowdary
(72)Name of Inventor :
1)Dr.Bogala Konda Reddy
2)Dr.Alluru Gopala Krishna
3)Nalband Noor Mahammad
4)Korla Mohanakrishna Chowdary

(57) Abstract :

ABSTRACT: Title: Adaptable Biomass Cooking Stove with Movable Combustion Chambers The present disclosure proposes an adaptable biomass cooking stove with movable combustion chambers that enables the user to vary the height of the stove according to the user requirement and increases the thermal efficiency of the stove. The adaptable biomass cooking stove comprises a base plate 107 which is configured to accommodate all the biomass cooking stove components, and wherein the biomass cooking stove components further comprises a rotating handle 101, a transmission chain 103, a pair of end sprockets 104, a pair of lead screws 105, a slider 106, a pair of scissor frames 109, a bowl stand 112, plurality of combustion chambers 110, plurality of air supply ducts 108, and a heat insulating bellow 111. The adaptable biomass cooking stove provides a robust mechanism for vertical adjustment that provides a self-locking system. The adaptable biomass stove aids to provide effective fuel usage, effective thermal efficiency, and better heat utilization. The adaptable biomass cooking stove is provided with a movable bellow that moves up and down along with the combustion chambers and acts as an insulator to avoid heat loss to surroundings. The adaptable biomass cooking stove enables the user to adjust the heat intensity in the biomass stove. The adaptable biomass cooking stove is of low-cost and allows the user to cook different types and different quantities of food.

No. of Pages : 24 No. of Claims : 10

(12) PATENT APPLICATION PUBLICATION

(21) Application
No.201941049844 A

(19) INDIA

(22) Date of filing of Application :04/12/2019

(43) Publication Date :
20/12/2019

(54) Title of the invention : NIXY TURMERIC STAIN REMOVER

(51)
International :A61K0036906600,A61K0031120000,C11D0017040000,C11D0003386000,B01J0029080000
classification
(31) Priority
Document :NA
No
(32) Priority :NA
Date
(33) Name
of priority :NA
country
(86)
International
Application :NA
No :NA
Filing
Date
(87)
International : NA
Publication
No
(61) Patent
of Addition
to
Application :NA
Number :NA
Filing
Date
(62)
Divisional to
Application :NA
Number :NA
Filing
Date

(71)**Name of Applicant**
:
**1)Mr. MAJDI
SALAH M
ALKATOUT**
Address of Applicant
:#B501, AKRUTHI
AMITY APARTMENT,
13TH CROSS,
ANANTHANAGAR,
ELECTRONICS CITY
PHASE 2,
BANGALORE-560100,
KARNATAKA, INDIA
Karnataka India
(72)**Name of Inventor** :
**1)Mr. MAJDI
SALAH M
ALKATOUT**

(57) Abstract :

Curcumin stains are considered as toughest stains on the fabrics and other materials. This invention comprises a composition and process for the effective reduction of stains, particularly turmeric stains that are resistant to simple washing, wiping, or the use of detergent-based spot stain removers. The present embodiment is a composition of citric acid solution, Sodium chloride solution with PH range 6-7, Sodium hypochlorite solution with PH above 8 which will resolve the above problem and shall remove the turmeric stains from the fabrics.

No. of Pages : 13 No. of Claims : 5

(12) PATENT APPLICATION PUBLICATION

(21) Application
No.201941050383 A

(19) INDIA

(22) Date of filing of Application :06/12/2019

(43) Publication Date :
20/12/2019

(54) Title of the invention : INNOVATIVE IDEA OF ADOPTING UNIVERSAL UNIQUE VEHICLE NUMBER CHIP

(51)
International :G06Q0010100000,A63F0013400000,H04L0009300000,G99Z0099000000,H02K0007180000
classification
(31) Priority
Document :NA
No
(32) Priority :NA
Date
(33) Name
of priority :NA
country
(86)
International
Application :NA
No :NA
Filing
Date
(87)
International
Publication : NA
No
(61) Patent
of Addition
to
Application :NA
Number :NA
Filing
Date
(62)
Divisional to
Application :NA
Number :NA
Filing
Date

(71)**Name of Applicant**
:
**1)PROF. JADHAV
VITHAL
HANUMANTARO**
Address of Applicant
:**OMSHREE BUILDING
2ND MAIN 5TH
CROSS
NARAYANPUR
DHARWAD
KARNATAKA INDIA-
580 008 Karnataka India**
(72)**Name of Inventor** :
**1)PROF. JADHAV
VITHAL
HANUMANTARO**

(57) Abstract :

Abstract: Here is a problem statement: It is an open secret that, criminals are using most of the time, different types of vehicles for their criminal activities all over the world. Best example is the Pulavama terrorist attack In India. Also we have witnessed many times that some Auto Rickshaw / Private Cabs drivers during night time playing criminal games with innocent people travelling in remote areas. Recently one incident has happened in Bengaluru during the night when one employee was travelling in an Auto was attacked by Auto driver nearby employee's house in an almost remote area. The employee had phoned his parents. Parents went for his rescue but the Auto driver tried to hit them also with is Auto and ran away. Boy (employee) was admitted to hospital and his head and hand were stitched for the mjaor injury. The auto driver has snatched the wristwatch, Wallet and Cell Phone from the Vitim. Unfortunately, since the incident took place during the night and also due to psycho fear, neither the employee nor his parents could note down the Auto number. A complaint has been lodged. Policemen had asked the victims to give the Auto number if noticed but it did not happen. So it is a difficult task for policemen also to trace the culprit without any evidence. To add to this recent rape cases in India are also witnessed.

No. of Pages : 8 No. of Claims : 5

(12) PATENT APPLICATION PUBLICATION

(21) Application No.201941050675 A

(19) INDIA

(22) Date of filing of Application :09/12/2019

(43) Publication Date : 20/12/2019

(54) Title of the invention : DESIGN AND DEVELOPMENT OF SMART WATER BOTTLE

(51) International classification :A47J27/21008
(31) Priority Document No :NA
(32) Priority Date :NA
(33) Name of priority country :NA
(86) International Application No :NA
Filing Date :NA
(87) International Publication No : NA
(61) Patent of Addition to Application Number :NA
Filing Date :NA
(62) Divisional to Application Number :NA
Filing Date :NA

(71)Name of Applicant :

1)VASUJADEVI MIDASALA

Address of Applicant :ASSISTANT PROSESSOR DEPT.
ECE, KLEF, VADDESARAM, GUNDUR DISTRICT
ANDHRA PRADESH Andhra Pradesh India

2)DR. S. NAGAKISHORE BHAVARAM

3)KUTTU BOYINA SANDEEEP

4)SARATH CHANDRA SUDANAGUNTA

(72)Name of Inventor :

1)VASUJADEVI MIDASALA

2)DR. S. NAGAKISHORE BHAVARAM

3)KUTTU BOYINA SANDEEEP

4)SARATH CHANDRA SUDANAGUNTA

(57) Abstract :

Water is an essential nutrient for human health. However, individuals may ignore drinking enough water due to the rush of everyday life. We present Grow, a conceptual smart bottle prototype designed to encourage users to drink water regularly. Our concept utilizes bottle surface as an ambient display instead of a traditional screen-based display to give feedback. Grow tracks daily water intake through an embedded liquid level sensor. It gives positive, abstract, non-intrusive and aesthetic feedback through heating up different parts of a thermo-chromic print on its surface. In this project, we implement a smart water bottle which measures the purity of the water content so that it helps in maintaining the purity of water. Fitness tracking also enabled with this smart water bottle which enables to calculate the heart rate, water intake, pulse rate, glucose level and calories burnt. These data are sent to the cloud directly and monitored periodically. Temperature of the bottle is also monitored for constant maintenance of temperature. After that water quality parameters are taken down for the constant monitoring of the health conditions and the daily intake of water level. These parameters are continuously monitored with amobile app which is specifically developed for this smart bottle and backup the datas to cloud.This helps in health monitoring system which makes the peoples health condition to be monitored periodically.

No. of Pages : 7 No. of Claims : 5

(12) PATENT APPLICATION PUBLICATION

(21) Application
No.201941050745 A

(19) INDIA

(22) Date of filing of Application :09/12/2019

(43) Publication Date :
20/12/2019

(54) Title of the invention : THERMAL VENTILATOR

(51)
International :F28D0020000000,G06F0017270000,A61M0016000000,F24F0007020000,F24F0007000000
classification
(31) Priority
Document :NA
No
(32) Priority :NA
Date
(33) Name
of priority :NA
country
(86)
International
Application :NA
No :NA
Filing
Date
(87)
International : NA
Publication
No
(61) Patent
of Addition
to
Application :NA
Number :NA
Filing
Date
(62)
Divisional to
Application :NA
Number :NA
Filing
Date

(71)**Name of Applicant :**
1)Dr. K. VISAGAVEL
Address of Applicant
:O.NO. 3/67, N.NO.3/95
T.
KAILASAMPALAYAM,
TIRUCHENGODE Tamil
Nadu India
(72)**Name of Inventor :**
1)Dr. K. VISAGAVEL
2)Dr. PSS.
SRINIVASAN

(57) Abstract :

The present invention relates to the field of natural thermal ventilation systems in buildings. The thermal ventilator (1) comprises of a connecting pipe (11), an air chamber (21), an absorber plate (31) and a discharge pipe (41). FIG - 2

No. of Pages : 16 No. of Claims : 8

(12) PATENT APPLICATION PUBLICATION

(21) Application No.201941050888 A

(19) INDIA

(22) Date of filing of Application :09/12/2019

(43) Publication Date : 20/12/2019

(54) Title of the invention : I-AUTOMOBILE: INTELLIGENT AUTOMOBILE WITH COMBINATION OF CAMERA, RADAR , ADVANCED SENCER-Q7 AND RADIO FREQUENCY COMMUNICATION WORK TOGETHER WITH SENSOR FUSION.

(51) International :B60Q0001340000,G06Q0040080000,B60Q0001400000,B60Q0001380000,B62J0006000000 classification
(31) Priority Document :NA
No
(32) Priority Date :NA
(33) Name of priority :NA
country
(86) International Application :NA
No :NA
Filing Date
(87) International Publication :NA
No
(61) Patent of Addition to Application :NA
Number :NA
Filing Date
(62) Divisional to Application :NA
Number :NA
Filing Date

(71)Name of Applicant :
1)DR. NALUGURU UDAYA KUMAR
Address of Applicant :MARRI LAXMAN REDDY INSTITUTE OF TECHNOLOGY AND MANAGEMENT, DUNDIGAL, HYDERABAD, TELANGANA 500043, INDIA joyudaya@gmail.com Telangana India
2)DR. SHIJIN KUMAR P.S
3)DR. ABHILASH K.S
4)DR. CHUKKA SANTHAIAH (ASSOCIATE PROFESSOR, CSE DEPT.)
5)INSTITUTE OF AERONAUTICAL ENGINEERING
(72)Name of Inventor :
1)DR. NALUGURU UDAYA KUMAR
2)DR. SHIJIN KUMAR P.S
3)DR. ABHILASH K.S
4)DR. CHUKKA SANTHAIAH (ASSOCIATE PROFESSOR, CSE DEPT.)
5)INSTITUTE OF AERONAUTICAL ENGINEERING

(57) Abstract :
I-AUTOMOBILE: INTELLIGENT AUTOMOBILE WITH COMBINATION OF CAMERA, RADAR , ADVANCED SENCER-Q7 AND RADIO FREQUENCY COMMUNICATION WORK TOGETHER WITH SENSOR FUSION. ABSTRACT My invention I-AUTOMOBILE • An intelligent turn signaling system is disclosed which uses trip information and global positioning system data to automatically activate the turn lights for a vehicle. In one implementation, the system can optimize vehicular flow by receiving trip information from nearby vehicles and prepare the vehicle and driver accordingly. In other implementations, the system can also optimize insurance premium for drivers who allow the system to recommend conservative driving techniques and also protect the accident possibility , accident location alert according to previous data base. 1. An intelligent turn signal control system for a driver, comprising a processor. 2. a positioning system coupled to the processor to provide vehicle position and turn-by-turn command. 3. an accelerometer coupled to the processor to sense vehicle acceleration. 4. a turn signal driver interface switch assembly configured to receive driver input to the processor. 5. a turn signal lamp actuation circuit configured to connect the processor to a plurality of turn signal lamps, wherein the processor selectively determines whether the turn signal lamp actuation circuit is turned on or off based at least on the positioning system turn-by-turn command and accelerometer output.

No. of Pages : 22 No. of Claims : 9

(12) PATENT APPLICATION PUBLICATION

(21) Application
No.201941050890 A

(19) INDIA

(22) Date of filing of Application :10/12/2019

(43) Publication Date :
20/12/2019

(54) Title of the invention : ARRANGEMENT FOR CONVERSION OF INTERNAL COMBUSTION ENGINE VEHICLE INTO ELECTRIC VEHICLE

(51)
International :B60W0020000000,B60K0006260000,B60K0007000000,B62D0059040000,B60W0010080000
classification
(31) Priority
Document :NA
No
(32) Priority :NA
Date
(33) Name
of priority :NA
country
(86)
International
Application :NA
No :NA
Filing
Date
(87)
International : NA
Publication
No
(61) Patent
of Addition
to
Application :NA
Number :NA
Filing
Date
(62)
Divisional to
Application :NA
Number :NA
Filing
Date

(71)**Name of Applicant :**
1)C.K.Dhanasekar
Address of
Applicant :No 10,
BHUVI Flats, G1, C
Block 1st Street, North
Jagannathan Nagar,
Villivakkam, Chennai
Tamil Nadu India
(72)**Name of Inventor**
:
1)C.K.Dhanasekar

(57) Abstract :

ARRANGEMENT FOR CONVERSION OF INTERNAL COMBUSTION ENGINE VEHICLE INTO ELECTRIC VEHICLE The present invention relates to arrangement (100) for conversion of IC engine vehicle into EV including a stator (101), a rotor (102), an electric drive controller and an energy storage device (103) for power source along with selector switches, throttle panels and control units (109). The stator (101) is placed on a separate plate (106) which is placed behind an existing axle hub (107) of front or rear wheel of the vehicle, and the rotor (102) is placed in the available space between the existing axle hub (107) and a wheel drum (108) of front or rear wheel of the vehicle. Further, the arrangement (100) includes a separate throttle or an existing accelerator pedal can be used for the electric mode vehicle to control the speed if the electric pedal deployed in the vehicle. Figure to be included with abstract: [Figures 2-3]

No. of Pages : 20 No. of Claims : 9

(12) PATENT APPLICATION PUBLICATION

(21) Application No.201941050938
A

(19) INDIA

(22) Date of filing of Application :10/12/2019

(43) Publication Date : 20/12/2019

(54) Title of the invention : MECHANICAL PNEUMATIC BLANKING AND EMBOSsing MACHINE

(51)
International :B44B0005000000,B21D0028140000,B21D0043280000,B21D0019000000,B23D0015060000
classification
(31) Priority
Document :NA
No
(32) Priority :NA
Date
(33) Name
of priority :NA
country
(86)
International
Application :NA
No :NA
Filing
Date
(87)
International : NA
Publication
No
(61) Patent
of Addition
to
Application :NA
Number :NA
Filing
Date
(62)
Divisional to
Application :NA
Number :NA
Filing
Date

(71)Name of Applicant :
**1)PRINCIPAL,DAYANANDA
SAGAR ACADEMY OF
TECHNOLOGY AND
MANAGEMENT**
Address of Applicant
:DAYANANDA SAGAR ACADEMY
OF TECHNOLOGY AND
MANAGEMENT, UDAYAPURA,
KANAKAPURA ROAD,OPPOSITE
TO ARTS OF
LEAVING,BANGALORE-
560082,KARNATAKA Karnataka
India
(72)Name of Inventor :
**1)DR.RAJANISH M.
2)MR.DEVARAJ H.
3)MR.MANOJKUMAR N.
4)MR.RAMKUMAR P.**

(57) Abstract :

The proposed invention is about the design and improvement of a remote control framework dependent Machine Tool which performs both Blanking and Embossing on sheet metal. In Blanking, process sheet metal piece is expelled from the enormous bit of stock by the applied shearing power utilizing a punch and bite the dust gathering to punch out a clear. In the Embossing procedure, the three-dimensional impression is given by applying pressure. A Revolving Die holder conveying four passes on at a similarly dispersed round about example empowers both Blanking and Embossing in a similar Machine Tool. The Designed Machine Tool has a remote control framework from where the operational groupings of both Pneumatic Cylinders and the Revolving Die Holder are controlled. Additionally, the machine is intended to deliver the required Blanking and Embossing power dependent on the thickness of the crude material utilized.

No. of Pages : 20 No. of Claims : 7

(12) PATENT APPLICATION PUBLICATION

(21) Application No.201941050968 A

(19) INDIA

(22) Date of filing of Application :10/12/2019

(43) Publication Date : 20/12/2019

(54) Title of the invention : A FACILE METHOD TO PREPARE MYCOSILVER NANOPARTICLES AND ITS THERAPEUTIC APPLICATIONS

(51) International classification	:A61K9/51	(71)Name of Applicant :
(31) Priority Document No	:NA	1)B.S.ABDUR RAHAMAN CRESCENT INSTITUTE OF
(32) Priority Date	:NA	SCIENCE AND TECHNOLOGY
(33) Name of priority country	:NA	Address of Applicant :GST ROAD CHENNAI TAMILNADU
(86) International Application No	:NA	INDIA-600048 Tamil Nadu India
Filing Date	:NA	(72)Name of Inventor :
(87) International Publication No	: NA	1)DR.S.HEMALATHA
(61) Patent of Addition to Application Number	:NA	2)SHARIQ AHMED.M
Filing Date	:NA	
(62) Divisional to Application Number	:NA	
Filing Date	:NA	

(57) Abstract :

Extracellular biosynthesis of the silver nanoparticles (AgNPs) was synthesized by using the endophytic fungus isolated from the medicinal plant Eupatorium triplinerve. The AgNPs were characterized by UV-Visible, FT-IR spectroscopy and SEM. The antimicrobial activity of the AgNPs was tested against Staphylococcus aureus under In vitro and In vivo conditions and showed growth inhibition.

No. of Pages : 13 No. of Claims : 3

(12) PATENT APPLICATION PUBLICATION

(21) Application No.201941050969 A

(19) INDIA

(22) Date of filing of Application :10/12/2019

(43) Publication Date : 20/12/2019

(54) Title of the invention : GREEN NANO PARTICLES AS NOVEL ANTIBIOTIC RESISTANCE BREAKERS AND HAVING SIGNIFICANT ANTICANCER

(51) International classification	:C09K8/80	(71)Name of Applicant :
(31) Priority Document No	:NA	1)B.S. ABDUR RAHAMAN CRESCENT INSTITUTE OF SCIENCE AND TECHNOLOGY,VANDALUR CHENNAI
(32) Priority Date	:NA	Address of Applicant :GST ROAD CHENNAI TAMILNADU
(33) Name of priority country	:NA	INDIA-600048 Tamil Nadu India
(86) International Application No	:NA	(72)Name of Inventor :
Filing Date	:NA	1)DR.S.HEMALATHA
(87) International Publication No	: NA	2)TAHIRA AKTHER
(61) Patent of Addition to Application Number	:NA	
Filing Date	:NA	
(62) Divisional to Application Number	:NA	
Filing Date	:NA	

(57) Abstract :

The main objective of the present invention is to demonstrate the antimicrobial and anticancer activity of biogenic novel silver nanoparticles. The present invention relates to the Biogenic synthesis of silver nanoparticles using endophytic fungi. Generally, fungi have the ability to secrete secondary metabolites which have the ability to reduce metal ions to metallic nanoparticles. In this report, silver nanoparticles (AgNPs) were synthesized by using an endophytic fungus isolated from the medicinal plant. The endophytic fungus was identified on the basis of ITS sequencing. The synthesized AgNPs were characterized by adopting various high-throughput techniques, scanning electron microscopy (SEM) equipped with energy dispersive X-ray analysis (EDAX), high-resolution transmission electron microscopy (HR-TEM) and UV-Visible spectrophotometer. In vitro anticancer efficacy of AgNPs was tested in lung cancer cell lines. The synthesized AgNPs were effective in scavenging free radicals and induced hallmarks of apoptosis including nuclear and DNA fragmentation in different cancer cell lines under in vitro conditions. The results suggested that the natural biomolecules in the endophytic fungi incorporated into the nanoparticles could be responsible for the synergetic cytotoxic activity against bacterial and cancer cells. The AgNPs were found to have cytotoxicity {IC50 of 40 pg/mL} against cancer cells. To the best of our knowledge, this is the first report demonstrating that AgNPs from this novel endophytic fungi could be able to induce apoptosis in various types of cancer cells and this is the novel strategy for cancer treatment.

No. of Pages : 18 No. of Claims : 5

(12) PATENT APPLICATION PUBLICATION

(21) Application No.201941050970 A

(19) INDIA

(22) Date of filing of Application :10/12/2019

(43) Publication Date : 20/12/2019

(54) Title of the invention : GREEN NANOCOLLOIDS AS EXTENDED-SPECTRUM-LACTAMASE (ESBL) INHIBITOR IN MULTIDRUG RESISTANT (MDR) ESCHERICHIA COLI

(51) International classification :C09K8/80
(31) Priority Document No :NA
(32) Priority Date :NA
(33) Name of priority country :NA
(86) International Application No :NA
Filing Date :NA
(87) International Publication No : NA
(61) Patent of Addition to Application Number :NA
Filing Date :NA
(62) Divisional to Application Number :NA
Filing Date :NA

(71)Name of Applicant :
1)B.S.Abdur Rahman Crescent Institute of Science and Technology
Address of Applicant :GST Road, Chennai, Tamilnadu, India-600048. Tamil Nadu India
(72)Name of Inventor :
1)Dr.S.Hemalatha
2)S.Ranjani

(57) Abstract :

The present invention is to demonstrate the bactericidal and antibiofilm potential of phyto compound and noble metal mediated nanocolloids against ESBL producing human pathogens. The nanocolloid formulation was confirmed through various physico-chemical characterization such as Uv-Visible spectrophotometer, Fourier Transform Infrared absorption spectrum, Particle size analyser, Zeta analyser, Field Emission-scanning electron microscope and Energy Dispersive X-Ray Analysis. The technology used to formulate the nanocolloid is novel and characterization studies confirmed the size, shape, stability, surface charge, morphology and the presence of essential elements required for the inhibition of bacterial growth. The novel Green Nanocolloids were tested against multi drug resistant (MDR) pathogenic Escherichia coli strains. Minimum inhibitory concentration, Minimum bactericidal concentration and antibiofilm assays were performed at different concentrations of nanocolloids. Further, the expression of virulent gene (CTXM-15) under extended-spectrum p-lactamase (ESBL) group, which is responsible for antibiotic resistance was analyzed through Polymerase Chain Reaction (PCR). Green nanocolloids showed better antibacterial and anti-biofilm activity as well as downregulated the expression of virulent gene CTXM-15. This invention shows that green nanocolloids act on CTXM-15 gene and thus inhibited ESBL enzyme production and growth in multi drug resistant E.coli.

No. of Pages : 17 No. of Claims : 4

(12) PATENT APPLICATION PUBLICATION

(21) Application No.201941050971 A

(19) INDIA

(22) Date of filing of Application :10/12/2019

(43) Publication Date : 20/12/2019

(54) Title of the invention : FLORAL BUD INCORPORATED NANO COLLOIDAL FORMULATION TO CONTROL PNEUMONIA CAUSING MULTIDRUG RESISTANT/ANTIBIOTIC K.PNEUMONINE

(51) International classification	:A61K 31/65	(71) Name of Applicant : 1)B.S.Abdur Rahman Crescent Institute of Science and Technology
(31) Priority Document No	:NA	Address of Applicant :GST Road, Chennai, Tamilnadu, India-600048. Tamil Nadu India
(32) Priority Date	:NA	
(33) Name of priority country	:NA	
(86) International Application No	:NA	(72) Name of Inventor :
Filing Date	:NA	1)Dr.S.Hemalatha
(87) International Publication No	: NA	2)S.Ranjani
(61) Patent of Addition to Application Number	:NA	
Filing Date	:NA	
(62) Divisional to Application Number	:NA	
Filing Date	:NA	

(57) Abstract :

The main objective of the present invention is to demonstrate the antimicrobial activity of floral bud extract incorporated green nanocolloids on pneumonia causing multidrug resistant/antibiotic resistant K. pneumoniae. The floral bud extract incorporated green nanocolloids formulation was confirmed through various characterization techniques such as Uv-Visible spectrophotometer, Fourier transform infrared absorption spectrum, Particle size analyser, Zeta potential analyser, Field Emission-scanning electron microscopic studies and Energy Dispersive X-Ray Analysis. This invention uses the technology, which produce effective antibacterial nanocolloids with unique properties. The nanocolloid was validated for its effective antibacterial activity through series of tests such as Minimum susceptibility concentration and minimum concentration to kill the pneumonia causing multidrug resistant K. pneumoniae. Further the effect of nanocolloid was validated for its antibiofilm potential, which is the major factor responsible for global infection. The results are most promising and support our invention to control pneumonia causing multidrug resistant/antibiotic resistant K. pneumonia with the novel formulation.

No. of Pages : 16 No. of Claims : 4

(12) PATENT APPLICATION PUBLICATION

(21) Application No.201941050972 A

(19) INDIA

(22) Date of filing of Application :10/12/2019

(43) Publication Date : 20/12/2019

(54) Title of the invention : FORMULATION OF NOVEL GREEN NANO COLLOIDS TO CONTROL ANTIBIOTIC RESISTANT PATHOGENS RESPONSIBLE FOR BOVINE MASTITIS

(51) International classification	:A61K 8/00	(71)Name of Applicant : 1)B.S.Abdur Rahman Crescent Institute of Science and Technology
(31) Priority Document No	:NA	Address of Applicant :GST Road, Chennai, Tamilnadu, India- 600048 Tamil Nadu India
(32) Priority Date	:NA	(72)Name of Inventor :
(33) Name of priority country	:NA	1)Dr.S.Hemalatha
(86) International Application No	:NA	2)S.Ranjani
Filing Date	:NA	
(87) International Publication No	: NA	
(61) Patent of Addition to Application Number	:NA	
Filing Date	:NA	
(62) Divisional to Application Number	:NA	
Filing Date	:NA	

(57) Abstract :

The current invention is to exhibit the antimicrobial activity of fabricated green nanocolloids synthesized using combinations of four different green sources against mastitis causing pathogens isolated from mastitis milk. The present invention relates to green formulation of nanocolloids using combinations of floral buds and myrobalans. This invention demonstrates the usage of unique combination of floral buds and myrobalans for making novel nano formulation. The formulated nanocolloid was physico-chemically characterized by using several techniques such as Uv-Visible spectrophotometer, Fourier transform infrared absorption spectrum, Particle size analyser, Zeta potential analyser, Field Emission-scanning electron microscopic studies and Energy Dispersive X-Ray Analysis. This invention uses unique combination of floral buds and myrobalans and novel technology for the formulation of nanocolloids. This invention come with the outcome of nanocolloidal formulation with effective antibacterial property against bovine mastitis causing pathogens isolated from milk. The antibacterial property was validated by several assays such as minimum dosage to inhibit the growth of organism and minimum dose to kill the organism. Further, the antibiofilm activity of nanocolloid was confirmed. These results confirmed that, this invention as a potent antibacterial and antibiofilm agent to control the infection of antibiotic resistant pathogens responsible for bovine Mastitis. This nanocolloidal formulation will prevent the mastitis disease in bovine by inhibiting this disease-causing bacterial pathogen.

No. of Pages : 15 No. of Claims : 4

(12) PATENT APPLICATION PUBLICATION

(21) Application No.201941050973 A

(19) INDIA

(22) Date of filing of Application :10/12/2019

(43) Publication Date : 20/12/2019

(54) Title of the invention : AROMATIC NANO FORMULATION AS ANTIBIOTIC RESISTANCE BREAKERS IN BIOFILM FORMING PATHOGENIC STRAINS

(51) International classification	:A61K31/70	(71)Name of Applicant :
(31) Priority Document No	:NA	1)B.S.Abdur Rahman Crescent Institute of Science and Technology
(32) Priority Date	:NA	Address of Applicant :GST Road, Chennai, Tamilnadu, India-600048. Tamil Nadu India
(33) Name of priority country	:NA	(72)Name of Inventor :
(86) International Application No	:NA	1)Dr.S.Hemalatha
Filing Date	:NA	2)S.Ranjani
(87) International Publication No	: NA	
(61) Patent of Addition to Application Number	:NA	
Filing Date	:NA	
(62) Divisional to Application Number	:NA	
Filing Date	:NA	

(57) Abstract :

The present invention demonstrates the green nano colloids formulated from bark as antibiotic resistance breakers in biofilm forming antibiotic resistant/multidrug resistant human pathogens isolated from clinical samples. The present invention relates to green formulation of nanocolloids using aromatic compounds from bark. The formulation was characterized by using UV-Visible spectrophotometer, which confirms by forming the SPR peak, FT-IR spectrum to observe the foot prints present in the aromatic extract and synthesized nanocolloids, Particle size analyser to measure the diameter of nanoparticle based on Brownian movement, Zeta analyser to observe the stability of the nanocolloids, FESEM microscopic image to observe the size of nanocolloids and EDAX analysis to find out the elemental composition of formulated nanocolloids. This invention uses the technology, which produces effective aromatic antibacterial-nanocolloids as antibiotic resistance breaker. The antibacterial potential of formulated nanocolloids was validated by minimum inhibitory concentration, minimum bactericidal concentration, which effectively inhibits and kills the pathogenic bacteria. Further the aromatic nanoformulations are evaluated to check the antibiofilm potential against biofilm forming MDR pathogenic strains. From these assays it was observed that aromatic nanocolloids acted as potent antibiotic resistance breaker in biofilm forming MDR pathogenic bacteria.

No. of Pages : 16 No. of Claims : 4

(12) PATENT APPLICATION PUBLICATION

(21) Application No.201941050974 A

(19) INDIA

(22) Date of filing of Application :10/12/2019

(43) Publication Date : 20/12/2019

(54) Title of the invention : SCENTED NANOCOLLOIDAL FORMULATION AS MULTIDRUG RESISTANT BREAKERS IN URINARY TRACT INFECTION (UTI) CAUSING HUMAN PATHOGENS

(51) International classification	:a61K 9/00	(71)Name of Applicant : 1)B.S.Abdur Rahman Crescent Institute of Science and Technology
(31) Priority Document No	:NA	Address of Applicant :GST Road, Chennai, Tamilnadu, India-600048. Tamil Nadu India
(32) Priority Date	:NA	
(33) Name of priority country	:NA	
(86) International Application No	:NA	(72)Name of Inventor :
Filing Date	:NA	1)Dr.S.Hemalatha
(87) International Publication No	: NA	2)S.Ranjani
(61) Patent of Addition to Application Number	:NA	
Filing Date	:NA	
(62) Divisional to Application Number	:NA	
Filing Date	:NA	

(57) Abstract :

The main objective of the present invention is to demonstrate the antimicrobial activity of scented nanocolloidal formulation in multidrug resistant/antibiotic resistant urinary tract infection (UTT) causing human pathogens. The present invention relates to scented nanocolloidal formulation using scented green source. This invention uses the technology to formulate scented nanocolloid from aromatic plant as a green source. The formulated scented nanocolloids were biophysically and physio-chemically characterized using various techniques such as Uv-Visible spectrophotometer, Fourier transform infrared absorption spectrum, Particle size analyser, Zeta potential analyser, Field Emission-scanning electron microscopic studies and Energy Dispersive X-Ray Analysis. The nanocolloid was validated for its effective antibacterial activity through series of assays such as Minimum susceptibility concentration and minimum concentration to inhibit and to control the UTI causing multidrug resistant pathogens. Further, the effect of nanocolloid was validated for its antibacterial and antibiofilm potential in UTI causing multidrug resistant pathogens. The results are most promising and supports our invention to control multidrug resistant pathogens by acting as antibiotic resistance breakers in UTI causing human pathogens.

No. of Pages : 17 No. of Claims : 4

(12) PATENT APPLICATION PUBLICATION

(21) Application No.201941050976 A

(19) INDIA

(22) Date of filing of Application :10/12/2019

(43) Publication Date : 20/12/2019

(54) Title of the invention : POTENT GREEN NANOCOLLOIDS CONTROL GROWTH, BIOFILM FORMATION AND VIRULENCE IN ANTIBIOTIC RESISTANT

(51) International classification :A23L3/3463
(31) Priority Document No :NA
(32) Priority Date :NA
(33) Name of priority country :NA
(86) International Application No :NA
Filing Date :NA
(87) International Publication No : NA
(61) Patent of Addition to Application Number :NA
Filing Date :NA
(62) Divisional to Application Number :NA
Filing Date :NA

(71)Name of Applicant :
1)B.S.ABDUR RAHMAN CRESCENT INSTITUTE OF SCIENCE AND TECHNOLOGY
Address of Applicant :GST ROAD, VANDALUR, CHENNAI - 600 048, TAMILNADU. Tamil Nadu India

(72)Name of Inventor :
1)Dr.S.HEMALATHA
2)S.RANJANI

(57) Abstract :

The main objective of the present invention is to demonstrate the bactericidal and antibiofilm potential of phytocompound and noble metal mediated nanocolloids against antibiotic resistant strains isolated from tannery effluent. The present invention relates to the phytocompound mediated nanocolloid formulation using green source as dried leaf powder. This current invention is focused on green nanocolloid formulation to eliminate the antibiotic resistant strains from tannery effluent and make it beneficial to the society. The treated effluent can be used for making bricks, landfills and for agricultural purpose. Various physio chemical characterization such as UV-Vis spectrum, FT-TR spectrum, Particle size analysis, Zeta potential analysis, FESEM and elemental analysis using EDAX were employed to identify the characteristic features of green silver nanocolloids. Antibacterial and antibiofilm assays were performed to validate the efficacy of green nanocolloids. The results showed that green nanocolloids possess effective antibacterial and antibiofilm activity against antibiotic resistant strains isolated from tannery effluent. By using this nanocolloidal formulation MDR strains can be killed and then it can be released into the environment. In this way, development of new antibiotic resistant strains by horizontal gene transfer from one species to other species in the ecosystem can be prevented. This green nanocolloids could be the alternate source to eradicate antibiotic resistant strains thriving in the tannery effluent. In future, this formulation can be employed as a nanospary to avoid the spread of antibiotic resistant strains entering into human and animal system. This invention will be the great benefit to the society to provide people with better resources and to establish an environment that is antibiotic resistance free and eco-friendly.

No. of Pages : 16 No. of Claims : 4

(12) PATENT APPLICATION PUBLICATION

(21) Application No.201941050977 A

(19) INDIA

(22) Date of filing of Application :10/12/2019

(43) Publication Date : 20/12/2019

(54) Title of the invention : HEXANANOCOLLOID FORMULATION AS POTENT ANTIBIOTIC RESISTANT BREAKER

(51) International classification	:C12N15/81	(71)Name of Applicant :
(31) Priority Document No	:NA	1)B.S.ABDUR RAHMAN CRESCENT INSTITUTE OF SCIENCE AND TECHNOLOGY
(32) Priority Date	:NA	Address of Applicant :GST ROAD, VANDALUR, CHENNAI
(33) Name of priority country	:NA	- 600 048, TAMILNADU Tamil Nadu India
(86) International Application No	:NA	(72)Name of Inventor :
Filing Date	:NA	1)Dr.S.HEMALATHA
(87) International Publication No	: NA	2)S.RANJANI
(61) Patent of Addition to Application Number	:NA	
Filing Date	:NA	
(62) Divisional to Application Number	:NA	
Filing Date	:NA	

(57) Abstract :

The main objective of the present invention is to demonstrate the bactericidal and antibiofilm potential of phytochemicals from six green sources and noble metal mediated nanocolloids against antibiotic resistant animal pathogens causing bovine mastitis. The present invention relates to the phytochemical mediated nanocolloid formulation using combinations of green source. This invention demonstrates the usage of unique combination of six different green sources used for nanocolloid formulation. The formulated nanocolloid was physico-chemically characterized by using Uv-Visible spectrophotometer, Fourier transform infrared absorption spectrum, Particle size analyser, Zeta potential analyser, Field Emission-scanning electron microscopic studies and Energy Dispersive X-Ray Analysis. This invention uses unique combination of six different green sources and technology for the formulation of hexananocolloids. This invention come with the outcome of Hexananocolloidal formulation with effective antibacterial property against bovine mastitis causing pathogens isolated from milk and human pathogens isolated from clinical samples. The antibacterial property was validated by means of minimum concentration to inhibit the growth of organism and minimum concentration to kill the organism. Further the antibiofilm activity of Hexananocolloid was confirmed through biofilm formation assay. These results confirmed that, hexananocolloid as a potent antibacterial and antibiofilm agent to control the infection caused by antibiotic resistant pathogens

No. of Pages : 16 No. of Claims : 4

(12) PATENT APPLICATION PUBLICATION

(21) Application No.201941050978 A

(19) INDIA

(22) Date of filing of Application :10/12/2019

(43) Publication Date : 20/12/2019

(54) Title of the invention : PETALIC NANOCOLLOIDS AS BATTALION FOR PENICILLIN RESISTANT BACTERIAL STRAINS ISOLATED FROM TANNERY

(51) International classification	:C12R1/07	(71)Name of Applicant :
(31) Priority Document No	:NA	1)B.S.ABDUR RAHMAN CRESCENT INSTITUTE OF SCIENCE AND TECHNOLOGY
(32) Priority Date	:NA	Address of Applicant :GST ROAD, VANDALUR, CHENNAI
(33) Name of priority country	:NA	- 600 048, TAMILNADU. Tamil Nadu India
(86) International Application No	:NA	(72)Name of Inventor :
Filing Date	:NA	1)Dr.S.HEMALATHA
(87) International Publication No	: NA	2)S.RANJANI
(61) Patent of Addition to Application Number	:NA	
Filing Date	:NA	
(62) Divisional to Application Number	:NA	
Filing Date	:NA	

(57) Abstract :

The main objective of the present invention is to demonstrate the antimicrobial activity of floral petal extract coated green nanocolloids on penicillin resistant pathogens isolated from tannery effluent. The present invention relates to green formulation of nanocolloids using floral petal extract as a green source. The floral petal extract coated green nanocolloids formulation was confirmed through various characterization techniques such as Uv-Visible spectrophotometer, Fourier transform infrared absorption spectrum, Particle size analyser, Zeta potential analyser, Field Emission-scanning electron microscopic studies and Energy Dispersive X-Ray Analysis. This invention uses the technology, which produce effective antibacterial nanocolloids with unique properties. The nanocolloid was evaluated for its effective antibacterial activity through series of tests such as Minimum susceptibility concentration and minimum concentration to kill the penicillin resistant strains isolated from tannery effluent. Further the effect of nanocolloid was validated for its antibiofilm potential, which is the major causative for global outbreak of several infections. The results support our invention as a potent nano colloidal formulation to control penicillin resistant strains isolated from tannery effluent. This invention has been undertaken for the benefit of the society to provide people with better resources and to establish an environment that is disease free and to prevent the development of antibiotic resistant strains.

No. of Pages : 17 No. of Claims : 4

(12) PATENT APPLICATION PUBLICATION

(21) Application No.201941050979 A

(19) INDIA

(22) Date of filing of Application :10/12/2019

(43) Publication Date : 20/12/2019

(54) Title of the invention : BREAKING ANTIBIOTIC RESISTANCE BY USING NANOCOLLOIDS IN PATHOGENIC BACTERIAL STRAINS ISOLATED FROM DIABETIC WOUND

(51) International classification :A61K9/0063
(31) Priority Document No :NA
(32) Priority Date :NA
(33) Name of priority country :NA
(86) International Application No :NA
Filing Date :NA
(87) International Publication No : NA
(61) Patent of Addition to Application Number :NA
Filing Date :NA
(62) Divisional to Application Number :NA
Filing Date :NA

(71)Name of Applicant :
1)B.S.ABDUR RAHMAN CRESCENT INSTITUTE OF SCIENCE AND TECHNOLOGY
Address of Applicant :GST ROAD, VANDALUR, CHENNAI - 600 048, TAMILNADU. Tamil Nadu India

(72)Name of Inventor :
1)Dr.S.HEMALATHA
2)S.RANJANI

(57) Abstract :

The main objective of the present invention is to demonstrate the bactericidal and antibiofilm potential of phytocompound and noble metal mediated nanocolloids against antibiotic resistant strains isolated from diabetic wound. The present invention relates to the phytocompound mediated nanocolloid formulation using seeds as a green source. This invention uses the technology to formulate nanocolloid from aromatic seed as a green source. This current invention is focused on technology to formulate green nanocolloid to eliminate the antibiotic resistant pathogenic bacteria isolated from diabetic wound. The formulated nanocolloids are physico-chemically characterized using various techniques such as Uv-Visible spectrophotometer, Fourier transform infrared absorption spectrum, Particle size analyser, Zeta potential analyser, Field Emission-scanning electron microscopic studies and Energy Dispersive X-Ray Analysis. The nanocolloid was validated for its effective antibacterial activity through series of assays such as Minimum susceptibility concentration and minimum concentration to inhibit and to kill the diabetic wound causing multidrug resistant pathogens. Further the effect of nanocolloid was validated for its antibiofilm potential, which is the major cause for many infections. The results are promising and support our invention as a potent nano colloidal formulation as multidrug resistant breakers in diabetic wound causing human pathogens.

No. of Pages : 16 No. of Claims : 4

(12) PATENT APPLICATION PUBLICATION

(21) Application No.201941050980 A

(19) INDIA

(22) Date of filing of Application :10/12/2019

(43) Publication Date : 20/12/2019

(54) Title of the invention : TRI-GREEN NANO FORMULATION TO CONTROL PATHOGENS CAUSING MASTITIS AND RESPIRATORY INFECTION

(51) International classification :C07K14/535
(31) Priority Document No :NA
(32) Priority Date :NA
(33) Name of priority country :NA
(86) International Application No :NA
Filing Date :NA
(87) International Publication No : NA
(61) Patent of Addition to Application Number :NA
Filing Date :NA
(62) Divisional to Application Number :NA
Filing Date :NA

(71)Name of Applicant :
1)B.S.ABDUR RAHMAN CRESCENT INSTITUTE OF SCIENCE AND TECHNOLOGY
Address of Applicant :GST ROAD, VANDALUR, CHENNAI - 600 048, TAMILNADU. Tamil Nadu India

(72)Name of Inventor :
1)Dr.S.HEMALATHA
2)S.RANJANI

(57) Abstract :

The main objective of the present invention is to demonstrate the antimicrobial activity of fabricated green Tri-green nanocolloids synthesized using combinations of three different green sources against mastitis causing pathogens isolated from mastitis milk and human pathogens. The present invention relates to green formulation of nanocolloids using combinations of three different myrobalans as a green source. This invention focuses on technology with novel combinations of green source to formulate Tri green nnaocolloids. The green nanocolloidal formulation was confirmed through various characterization techniques such as Uv-Visible spectrophotometer, Fourier transform infrared absorption spectrum, Particle size analyser, Zeta potential analyser, Field Emission-scanning electron microscopic studies and Energy Dispersive X-Ray Analysis. This invention uses the technology, which produce effective antibacterial nanocolloids with unique properties. The nanocolloid was validated for its effective antibacterial activity through series of tests such as minimum susceptibility concentration and minimum concentration to kill the multidrug resistan pathogens isolated from bovine mastitis and human respiratory infection. Further the effect of nanocolloid was validated for its antibiofilm potential, which is the major causative for global spread of infection. The results are most promising and supports our invention as a potent nano colloidal formulation to control mastitis causing multidrug resistant/antibiotic resistant pathogens and respiratory disease-causing pathogens.

No. of Pages : 19 No. of Claims : 4

(12) PATENT APPLICATION PUBLICATION

(21) Application No.201941050981 A

(19) INDIA

(22) Date of filing of Application :10/12/2019

(43) Publication Date : 20/12/2019

(54) Title of the invention : ENDOPHYTIC NANO PARTICLES SUPPRESS BIOFILM FORMATION IN HUMAN PATHOGENS

(51) International classification	:A01N 63/00	(71) Name of Applicant : 1)B.S.Abdur Rahman
(31) Priority Document No	:NA	Address of Applicant :Crescent Institute of Science and
(32) Priority Date	:NA	Technology, GST road, Vandalur, Chennai-600048. Tamil Nadu
(33) Name of priority country	:NA	India
(86) International Application No	:NA	(72) Name of Inventor :
Filing Date	:NA	1)Dr.S.Hemalatha
(87) International Publication No	: NA	2)Tahira Akther
(61) Patent of Addition to Application Number	:NA	
Filing Date	:NA	
(62) Divisional to Application Number	:NA	
Filing Date	:NA	

(57) Abstract :

Abstract of the invention:- The main objective of the present invention is to demonstrate the antimicrobial activity and biofilm inhibition of biogenic novel silver nanoparticles on human pathogens. The present invention relates to the Biogenic synthesis of silver nanoparticles using endophytic fungi. The Myco silver nanoparticles (AgNPs) are synthesized through bio-reduction reaction of silver nitrate by cell-free filtrate of endophytic fungi, which act as both reducing and capping agent. The synthesis of silver nanoparticles (AgNPs) was confirmed through UV-VIS spectroscopy, Fourier Transform Infrared (FTIR), Transmission Electron Microscope (TEM), Scanning Electron Microscope (SEM). Energy Dispersive spectroscopy (EDAX) was used to study the structure, morphology, shape, and composition of synthesized nanoparticles. The efficacy of the silver nanoparticles (AgNPs) was tested against the pathogenic bacterial strains. The myco silver nano particles treatment significantly reduced the growth of all the bacterial species and their biofilm formation tested in this study. The results suggested that myco nanoparticles can be utilized as an alternative to antibiotics or to break antimicrobial resistance.

No. of Pages : 16 No. of Claims : 4

(12) PATENT APPLICATION PUBLICATION

(21) Application No.201941050982 A

(19) INDIA

(22) Date of filing of Application :10/12/2019

(43) Publication Date : 20/12/2019

(54) Title of the invention : ENDOPHYTIC NANOPARTICLES AS AN ALTERNATIVE TO ANTIBIOTICS TO CONTROL PATHOGENIC BACTERIA

(51) International classification	:A61K 9/51	(71)Name of Applicant : 1)B.S.Abdur Rahman
(31) Priority Document No	:NA	Address of Applicant :Crescent Institute of Science and
(32) Priority Date	:NA	Technology, GST road, Vandalur, Chennai-600048. Tamil Nadu
(33) Name of priority country	:NA	India
(86) International Application No	:NA	(72)Name of Inventor :
Filing Date	:NA	1)Dr.S.Hemalatha
(87) International Publication No	: NA	2)Tahira Akther
(61) Patent of Addition to Application Number	:NA	
Filing Date	:NA	
(62) Divisional to Application Number	:NA	
Filing Date	:NA	

(57) Abstract :

Abstract of the invention:- The main objective of the present invention is to study the antimicrobial activity of these silver nanoparticles on human pathogens. The present invention relates to the Biogenic synthesis of silver nanoparticles using endophytic fungi. In the present study, efficient, eco-friendly and sustainable green chemistry method has been utilized for the synthesis of mycosilver nanoparticle. We have utilized the mycelium filtrate of endophytic fungiisolated from the stem of medicinal plant. The synthesized mycosilver nano particles were characterized by UV-Vis and FTIR spectroscopy, Scanning Electron Microscopy (SEM), Transmission Electron Microscopy (TEM) and Energy . Dispersive X-ray analysis (EDAX). The results of present study exhibited that mycosilver nanoparticles inhibited the growth and biofilm formation in multi drug resistant bacterialstrains. The results suggested that mycosilver nanoparticles can be employed as a substitute to antibiotics to break antibiotic resistance in MDR bacterial strains.

No. of Pages : 16 No. of Claims : 4

(54) Title of the invention : MYCONANO PARTICLES SUPPRESS THE COLONIZATION OF PLANT PATHOGENIC FUNGI

(51) International classification	:A23K 50/75	(71)Name of Applicant :
(31) Priority Document No	:NA	1) B.S.Abdur Rahman
(32) Priority Date	:NA	Address of Applicant :Crescent Institute of Science and
(33) Name of priority country	:NA	Technology, GST road, Vandalur, Chennai-600048. Tamil Nadu
(86) International Application No	:NA	India
Filing Date	:NA	(72)Name of Inventor :
(87) International Publication No	: NA	1)Dr.S.Hemalatha
(61) Patent of Addition to Application Number	:NA	2)Tahira Akther
Filing Date	:NA	
(62) Divisional to Application Number	:NA	
Filing Date	:NA	

(57) Abstract :

Abstract of the invention:- The main objectives of the present invention are to demonstrate the antifungal, antibacterial and anticancer activity of the biogenic novel silver nanoparticle. The present invention relates to the Biogenic synthesis of silver nanoparticles using endophytic fungi isolated from medicinal plant. The fungicides used to control plant pathogenic fungi not only kill the fungi but also affect other flora and fauna in the field. To preserve beneficial flora, novel strategies and alternative approaches should be identified. Bio-pesticides are used as an alternative to chemical fungicides. The development of nanotechnology-based fungicides and pesticides are considered as promising alternatives to preserve the biota. At the global level, researchers are working on nano-emulsion and nano-fungicides to control plant pathogenic fungi; however, farmers are unaware about these nano-based fungicides. Metal nanoparticles can act as potential fungicides when compared to the conventional chemical fungicides. Hence, our current study is based on utilization of the myco-nanoparticles synthesized from endophytic fungi isolated from medicinal plant. The mycosilver nanoparticles are characterized by SEM, TEM and EDAX analysis. The results of the study exhibited the silver nanoparticles were of different morphological shapes including spherical, cylindrical and loosely agglomerated with an average size of 250 nm. Further, the plant pathogenic fungi were treated with mycosilver nanoparticles to test the efficacy to control plant pathogens, and showed broad spectrum antifungal activity against the phytopathogens by inhibiting the radial growth. The efficacy of nanoparticles was tested against multidrug resistant pathogenic bacteria and showed antibacterial and antibiofilm activity. The nanoparticles also showed anticancer activity, however it did not kill the normal cells.

No. of Pages : 19 No. of Claims : 5

(12) PATENT APPLICATION PUBLICATION

(21) Application
No.201941050999 A

(19) INDIA

(22) Date of filing of Application :10/12/2019

(43) Publication Date :
20/12/2019

(54) Title of the invention : VC-DETECTION: VEHICLE CRASH DETECTION USING MACHINE LEARNING

(51)
International :G06N0020000000,G08B0025010000,G08G0001000000,B60R0021013200,G07C0005000000
classification
(31) Priority
Document :NA
No
(32) Priority :NA
Date
(33) Name
of priority :NA
country
(86)
International
Application :NA
No :NA
Filing
Date
(87)
International
Publication : NA
No
(61) Patent
of Addition
to :NA
Application :NA
Number :NA
Filing
Date
(62)
Divisional to
Application :NA
Number :NA
Filing
Date

(71)Name of Applicant
:
1)M
NAGABHUSHANA
RAO (PROFESSOR)
Address of
Applicant
:RAMACHANDRA
COLLEGE OF
ENGINEERING,
VATLURU, A.P-
534001, INDIA. Andhra
Pradesh India
2)DR. PUTTI
SRINIVASARAO
3)G.R.RAMA DEVI
4)SONALI
SHAILESH
BHOSALE
5)DR. AMIT
KUMAR TYAGI
6)GILLALA
REKHA
(72)Name of Inventor :
1)M
NAGABHUSHANA
RAO (PROFESSOR)
2)DR. PUTTI
SRINIVASARAO
3)G.R.RAMA DEVI
4)SONALI
SHAILESH
BHOSALE
5)DR. AMIT
KUMAR TYAGI
6)GILLALA
REKHA

(57) Abstract :

VC-Detection: VEHICLE CRASH DETECTION USING MACHINE LEARNING ABSTRACT My invention • VC-Detection€ • Vehicle collisions may be intelligent detected and reported based to a call center. The collisions may be automatically detected through machine learning based on a collision detection model that receives sensor data, or other machine learning provided data, as input, and outputs an indication of whether there is a collision. The collision detection model may be trained on historical sensor data associated with potential vehicle collisions, where the historical sensor data is labeled to indicate whether the data corresponds to an actual collision.

No. of Pages : 22 No. of Claims : 6

(12) PATENT APPLICATION PUBLICATION

(21) Application
No.201941051002 A

(19) INDIA

(22) Date of filing of Application :10/12/2019

(43) Publication Date :
20/12/2019

(54) Title of the invention : INTERACTIVE FOOD VENDING MACHINE FOR BLIND PEOPLE BASED ON VOICE RECOGNITION

(51)
International :G05D0023190000,G07F0017000000,G10L0015220000,G08C0017020000,G07D0005000000
classification
(31) Priority
Document :NA
No
(32) Priority :NA
Date
(33) Name
of priority :NA
country
(86)
International
Application :NA
No :NA
Filing
Date
(87)
International : NA
Publication
No
(61) Patent
of Addition
to
Application :NA
Number :NA
Filing
Date
(62)
Divisional to
Application :NA
Number :NA
Filing
Date

(71)**Name of Applicant**
:
**1)BHARATH
INSTITUTE OF
HIGHER
EDUCATION AND
RESEARCH**
Address of Applicant
:173, Agharam Road,
Selaiyur, Chennai 600
073 Tamil Nadu India
(72)**Name of Inventor** :
**1)K. Sakthivel
2)R.Rathika
3)S. Aarthi Suriya**

(57) Abstract :

ABSTRACT Interactive food vending machine for blind people based on voice recognition The invention relates to a voice controlled interactive vending machine, where the person can put a coin or credit card into the machine and select the desired food by talking to the machine via a microphone or using his android phone. This system is based on AT mega family micro controller, which when gets a signal from microphone gives the signal to start or stop the flow of food. Another feature of the machine is that IR sensors are placed at food outlet which is used to detect the presence or absence of plate / glass / cup. If the plate / glass / cup is not present it will notify the customers via display and a buzzer and will not start the flow. It also detects how much amount of plate is filled, if the plate is full the machine will stop the flow automatically.

No. of Pages : 7 No. of Claims : 2

(54) Title of the invention : HIGH-SPEED TRAIN SPEED PREDICTIVE CONTROL USING ANFIS MODELING AND MACHINE LEARNING

(51) International :G06N0020000000,B61L0027000000,B61L0003000000,G01M0001380000,B61L0023180000 classification

(31) Priority Document :NA
No

(32) Priority Date :NA

(33) Name of priority :NA
country

(86) International Application :NA
No :NA
Filing Date

(87) International Publication :NA
No

(61) Patent of Addition to Application :NA
Number :NA
Filing Date

(62) Divisional to Application :NA
Number :NA
Filing Date

(71)Name of Applicant :
1)ARPITHA KOTTE
Address of Applicant :KLEF DEEMED TO BE UNIVERSITY,OFF CAMPUS HYDERABAD, AZIZ NAGAR, HYDERABAD, TELANGANA-5000075, INDIA Telangana India
2)DR M.M.PRASADA REDDY
3)MANOJKUMAR UDGIRE
4)DR. ARUNA RAO S L (PROFESSOR BVIRIT HYDERABAD COLLEGE OF ENGINEERING FOR WOMEN)
5)DR.KUPPANI SATHISH
6)DR. G VIMALA KUMARI

(72)Name of Inventor :
1)ARPITHA KOTTE
2)DR M.M.PRASADA REDDY
3)MANOJKUMAR UDGIRE
4)DR. ARUNA RAO S L (PROFESSOR BVIRIT HYDERABAD COLLEGE OF ENGINEERING FOR WOMEN)
5)DR.KUPPANI SATHISH
6)DR. G VIMALA KUMARI

(57) Abstract :
HPML- Control: HIGH-SPEED TRAIN SPEED PREDICTIVE CONTROL USING ANFIS MODELING AND MACHINE LEARNING ABSTRACT My Invention isHPML- Control• A generalized predictive control method of high-speed train, the method is based ANFIS model and Machine learning (ML) train operation according to the process of rapid data acquisition, a method using a data-driven model, establishing a high-speed train ANFIS, ML process model, the determining the number of subtractive clustering rules and fuzzy model initial parameters, and using the back propagation algorithm and least square optimization fuzzy model parameters. The inventionHPML- Control• proposes a method for controlling the tracking speed prediction EMU ANFIS model, ML based, multi-step prediction, rolling cycle, to obtain accurate control of the amount of adjustment to vary the empirically blindness, high speed train speed accurately track the target curve, to solve a big lag, train punctuality achieve safe and effective operation to ensure the safety of passengers. The method of the invention is simple and practical for high-speed automatic train operation control. The inventionHPML- Control• is applicable to processes running on-line monitoring and automatic control of high-speed trains.

No. of Pages : 27 No. of Claims : 6

(12) PATENT APPLICATION PUBLICATION

(21) Application
No.201941051176 A

(19) INDIA

(22) Date of filing of Application :11/12/2019

(43) Publication Date :
20/12/2019

(54) Title of the invention : ARDUINO BASED AUTOMATIC ANTI-COLLISION SYSTEM

(51)
International :H04N0021250000,H04W0056000000,G06K0007100000,H04W0074080000,H04N0021478000
classification

(31) Priority
Document :NA
No

(32) Priority
Date :NA

(33) Name
of priority :NA
country

(86)
International
Application :NA
No :NA

Filing
Date

(87)
International
Publication : NA
No

(61) Patent
of Addition
to
Application :NA
Number :NA

Filing
Date

(62)
Divisional to
Application :NA
Number :NA

Filing
Date

(71)Name of
Applicant :
1)Vel Tech
Rangarajan Dr.
Sagunthala R&D
Institute of Science
and Technology
Address of
Applicant :No.42,
Avadi Vel Tech Road,
Avadi, Chennai - 600
062 Tamil Nadu, India
Tamil Nadu India

(72)Name of Inventor
:

1)Dr P.K DHAL
2)SHRIKANT
KUMAR SINGH
3)NIKITA
SHANKER

(57) Abstract :

ARDINO BASED AUTOMATIC ANTI-COLLISION SYSTEM The present invention relates to an anti-collision system where the vehicle with the ardino based automatic anti-collision system can be operated using an android app connected through biuetooth, the functioning of the Bluetooth module is also based on the aurdino programming. The running speed of the motor is controlled by the motor drive using the aurdino programming. This system helps to prevents from front and turning collision, less maintenance cost, less chance of people getting into serious injury and can be used in the areas where there are number of turnings. Main illustrative figure is Fig 1

No. of Pages : 12 No. of Claims : 4

(12) PATENT APPLICATION PUBLICATION

(21) Application
No.201941051177 A

(19) INDIA

(22) Date of filing of Application :11/12/2019

(43) Publication Date :
20/12/2019

(54) Title of the invention : A COMPOSITION OF GEOPOLYMER CLINKER AGGREGATE AND A PROCESS THEREOF

(51)
International :C04B0028000000,C04B0035626000,B32B0027120000,C04B0028260000,C08L0023200000
classification
(31) Priority
Document :NA
No
(32) Priority :NA
Date
(33) Name
of priority :NA
country
(86)
International
Application :NA
No :NA
Filing
Date
(87)
International : NA
Publication
No
(61) Patent
of Addition
to
Application :NA
Number :NA
Filing
Date
(62)
Divisional to
Application :NA
Number :NA
Filing
Date

(71)**Name of Applicant :**
1)Vel Tech
Rangarajan Dr.
Sagunthala R&D
Institute of Science and
Technology
Address of Applicant
:No.42, Avadi Vel Tech
Road, Avadi, Chennai -
600 062 Tamil Nadu,
India Tamil Nadu India
(72)**Name of Inventor :**
1)Udhaya Kumar. T

(57) Abstract :

A COMPOSITION OF GEOPOLYMER CLINKER AGGREGATE AND A PROCESS THEREOF The present invention generally relates to a composition of a Geopolymer clinker aggregate based on alkaline liquid containing soluble silicates, which is used as an alternative material for coarse aggregate resulting in excellent compressive strength, suffer very little drying shrinkage and is more suitable for structural applications. Main illustrative figure is Fig: 3

No. of Pages : 15 No. of Claims : 2

(12) PATENT APPLICATION PUBLICATION

(21) Application
No.201941051202 A

(19) INDIA

(22) Date of filing of Application :11/12/2019

(43) Publication Date :
20/12/2019

(54) Title of the invention : POWER TRANSFER OF GRID CONNECTED WIND FARM SYSTEM USING AN INTERLINE POWER FLOW CONTROLLER

(51)
International :H02J0003380000,H02J0003180000,G05F0001700000,H02J0003240000,H02J0003500000
classification
(31) Priority
Document :NA
No
(32) Priority :NA
Date
(33) Name
of priority :NA
country
(86)
International
Application :NA
No :NA
Filing
Date
(87)
International : NA
Publication
No
(61) Patent
of Addition
to
Application :NA
Number :NA
Filing
Date
(62)
Divisional to
Application :NA
Number :NA
Filing
Date

(71)**Name of Applicant :**
1)Dr.G.Radhakrishnan
Address of Applicant
:Department of Electrical &
Electronics Engineering Sri
Krishna College of
Engineering & Technology
Coimbatore- 641 008 Tamil
Nadu India
2)Elam Cheren.S
3)S.Sureshkumar
4)Vignesh T
(72)**Name of Inventor :**
1)Dr.G.Radhakrishnan
2)Elam Cheren.S
3)S.Sureshkumar
4)Vignesh T

(57) Abstract :

Our main objective of this research is to enhance the efficient power transmission in a grid connected power system by reducing the losses, and to reduce the reactive power generation in a transmission lines. This system can provide and enable a steady state power system to stable the grid connected power system with adequate real and reactive power transfer between the multiple lines.

No. of Pages : 7 No. of Claims : 5

(12) PATENT APPLICATION PUBLICATION

(21) Application
No.201941051206 A

(19) INDIA

(22) Date of filing of Application :11/12/2019

(43) Publication Date :
20/12/2019

(54) Title of the invention : PROCESS FOR DELAYED RIPENING OF BANANA USING TEMPERATURE AND HUMIDITY FOR PROLONGED SHELF LIFE

(51)
International :A23B0007148000,C10B0057040000,A23L0007109000,A23L0003341800,F25D0017040000
classification
(31) Priority
Document :NA
No
(32) Priority :NA
Date
(33) Name
of priority :NA
country
(86)
International
Application :NA
No :NA
Filing
Date
(87)
International : NA
Publication
No
(61) Patent
of Addition
to
Application :NA
Number :NA
Filing
Date
(62)
Divisional to
Application :NA
Number :NA
Filing
Date

(71)**Name of Applicant :**
1)D. Suresh Sanjaay
Address of Applicant
:A.R.Devarajulu Naidu
& Son, Muruga
Bhavanam, No. 751,
Poonamalli High Road,
Kilpauk, Chennai Tamil
Nadu India
**2)S.K. Shravan
Sankar**
3)S. Kavitha
(72)**Name of Inventor :**
1)D. Suresh Sanjaay
**2)S.K. Shravan
Sankar**
3)S. Kavitha

(57) Abstract :

ABSTRACT Process for delayed ripening of banana using temperature and humidity comprises maintaining of the optimum temperature at 12-14°C, and an optimum humidity at 80-95% in cold storage room. The said process of delayed ripening provides nutritional value, enzymes and microbial activity at a constant rate. The present invention provides prolongation of shelf life for 30 days by maintaining the bananas at good taste and quality.

No. of Pages : 28 No. of Claims : 5

(12) PATENT APPLICATION PUBLICATION

(21) Application
No.201941051268 A

(19) INDIA

(22) Date of filing of Application :11/12/2019

(43) Publication Date : 20/12/2019

(54) Title of the invention : HIGH-SPEED TRAIN SPEED PREDICTIVE CONTROL USING ANFIS MODELING AND MACHINE LEARNING, DEEP LEARNING

(51)
International :G06N0003080000,G06N0020000000,G06N0003040000,G05B0013040000,B61L0027000000
classification
(31) Priority
Document :NA
No
(32) Priority :NA
Date
(33) Name
of priority :NA
country
(86)
International
Application :NA
No :NA
Filing
Date
(87)
International : NA
Publication
No
(61) Patent
of Addition
to
Application :NA
Number :NA
Filing
Date
(62)
Divisional to
Application :NA
Number :NA
Filing
Date

(71)Name of Applicant :
1)DR.B.STALIN
Address of Applicant :ANNA
UNIVERSITY, REGIONAL
CAMPUS MADURAI
KEELAKUILKUDI, MADURAI-
625019. TAMIL NADU, INDIA. Pan
no:BZQPS5110P e- mail:
stalin1312@gmail.com mo
no:9865264158 Tamil Nadu India
2)DR.S.MARICHAMY
3)DR.S.J.SUBHASHINI
4)DR.V.DHINAKARAN
5)D.SELVAPANDIAN
6)J.VAIRAMUTHU
(72)Name of Inventor :
1)DR.B.STALIN
2)DR.S.MARICHAMY
3)DR.S.J.SUBHASHINI
4)DR.V.DHINAKARAN
5)D.SELVAPANDIAN
6)J.VAIRAMUTHU

(57) Abstract :

HIGH-SPEED TRAIN SPEED PREDICTIVE CONTROL USING ANFIS MODELING AND MACHINE LEARNING, DEEP LEARNING
ABSTRACT My Invention isHIGH-SPEED TRAIN SPEED PREDICTIVE CONTROL USING ANFIS MODELING AND MACHINE
LEARNING, DEEP LEARNING • A generalized predictive control method of high-speed train, the method is based ANFIS model and Machine
learning (ML) train operation according to the process of rapid data acquisition, a method using a data-driven model, establishing a high-speed train
ANFIS, ML process model, the determining the number of subtractive clustering rules and fuzzy model initial parameters, and using the back
propagation algorithm and least square optimization fuzzy model parameters. The inventionHIGH-SPEED TRAIN SPEED PREDICTIVE
CONTROL USING ANFIS MODELING AND MACHINE LEARNING, DEEP LEARNING€ • proposes a method for controlling the tracking
speed prediction EMU ANFIS model, ML based, multi-step prediction, rolling cycle, to obtain accurate control of the amount of adjustment to vary
the empirically blindness, high speed train speed accurately track the target curve, to solve a big lag, train punctuality achieve safe and effective
operation to ensure the safety of passengers. The method of the invention is simple and practical for high-speed automatic train operation control.
The inventionHIGH-SPEED TRAIN SPEED PREDICTIVE CONTROL USING ANFIS MODELING AND MACHINE LEARNING, DEEP
LEARNING • is applicable to processes running on-line monitoring and automatic control of high-speed trains.

No. of Pages : 25 No. of Claims : 3

(12) PATENT APPLICATION PUBLICATION

(21) Application
No.201941051351 A

(19) INDIA

(22) Date of filing of Application :11/12/2019

(43) Publication Date :
20/12/2019

(54) Title of the invention : AN ALERTNESS MONITORING AND WARNING SYSTEM FOR A DRIVER AND A METHOD THEREOF

(51)
International :G08B0021060000,G08G0001160000,H04M0001725000,B60K0028060000,B60R0016023000
classification

(31) Priority
Document :NA
No

(32) Priority :NA
Date

(33) Name
of priority :NA
country

(86)
International
Application :NA
No :NA

Filing
Date

(87)
International : NA
Publication
No

(61) Patent
of Addition
to
Application :NA
Number :NA
Filing

Date

(62)
Divisional to
Application :NA
Number :NA
Filing

Date

(71)Name of Applicant
:

**1)SRM Institute of
Science and
Technology**
Address of
Applicant
:Kattankulathur,
Chennai-603203, Tamil
Nadu, India Tamil Nadu
India

(72)Name of Inventor :

**1)Thummaginjala
Hima Varsha Tharaga
2)Chandrasekar
Anuradha
3)Subramanian
Vijayalakshmi
4)Thummaginjala
Hima Harsha Thapase
5)Dandi Rajesh
Moneesh**

(57) Abstract :

ABSTRACT AN ALERTNESS MONITORING AND WARNING SYSTEM FOR A DRIVER AND A METHOD THEREOF The present disclosure relates to field of alertness monitoring and warning. An alertness monitoring and warning system (100) for a driver comprises an analyser, a warning module and a control unit. The analyser (102) receives input from the driver, and generates a no input signal when no the input is received within a pre-determined time set by a timer (104). The warning module (106) set and increment a value of a counter on receiving the no input signal to provide warning to alert the driver, and generates subsequent final warning commands based on the counter value. The warning module (106) resets the counter on receiving the inputs and generates and transmits a partial brake command on receiving the final warning to an actuator of the automobile driven by the driver to apply partial brakes and warn the driver. The system (100) enhances safety of drivers and passengers, and reduces accidents.

No. of Pages : 17 No. of Claims : 7

(12) PATENT APPLICATION PUBLICATION

(21) Application
No.201941051364 A

(19) INDIA

(22) Date of filing of Application :11/12/2019

(43) Publication Date :
20/12/2019

(54) Title of the invention : MACHINE LEARNING BASED DATA MINING METHOD OF BIOMEDICAL DATASET USING NATURAL LANGUAGE PROCESSING

(51)
International :G06F0017270000,G06N0020000000,G10L0015260000,G16H0050200000,G16H0010600000
classification

(31) Priority
Document :NA
No

(32) Priority :NA
Date

(33) Name
of priority :NA
country

(86)
International
Application :NA
No :NA

Filing
Date

(87)
International : NA
Publication
No

(61) Patent
of Addition
to
Application :NA
Number :NA

Filing
Date

(62)
Divisional to
Application :NA
Number :NA

Filing
Date

(71)**Name of Applicant**
:
**1)Dr. K Yogeswara
Rao**

Address of
Applicant :Associate
Professor Department of
CSE, Aditya Institute of
Technology and
Management, Andhra
Pradesh, India Andhra
Pradesh India

2)Dr. G.S.N.Murty
(72)**Name of Inventor :**

**1)Dr. K Yogeswara
Rao**

2)Dr. G.S.N.Murty

(57) Abstract :

The present invention relates to machine learning-based data mining method of biomedical dataset using natural language processing. The objective of the present invention is to overcome the inadequacies of the prior arts in data mining method of biomedical dataset using natural language processing.

No. of Pages : 20 No. of Claims : 6

(12) PATENT APPLICATION PUBLICATION

(21) Application
No.201941051377 A

(19) INDIA

(22) Date of filing of Application :11/12/2019

(43) Publication Date :
20/12/2019

(54) Title of the invention : COMPACT MIMO ANTENNA FOR RADAR APPLICATIONS AND METHOD OF DESIGN THEREOF

(51)
International :H01Q0021280000,H01Q0001520000,H04B0007060000,H01Q0021240000,H01Q0009040000
classification
(31) Priority
Document :NA
No
(32) Priority :NA
Date
(33) Name
of priority :NA
country
(86)
International
Application :NA
No :NA
Filing
Date
(87)
International
Publication : NA
No
(61) Patent
of Addition
to
Application :NA
Number :NA
Filing
Date
(62)
Divisional to
Application :NA
Number :NA
Filing
Date

(71)Name of Applicant
:

**1)Mr. Praveen
Kumar Joshi**
Address of
Applicant :Assistant
Professor. Department
of Electrical &
Electronics
Engineering,
Muffakhahjah College
of Engineering and
Technology,Hyderabad,
Dist: Telengana, India
Telangana India
**2)Dr.C.Divya
3)Dr. Garima
Mathur
4)Dr. Aijaz Ali Khan
5)Dr. Greesh Kumar
Singh
6)Quazi
Mateenuddin
Hameeduddin
7)Priyanka Sharma**
(72)Name of Inventor :
**1)Mr. Praveen
Kumar Joshi
2)Dr.C.Divya
3)Dr. Garima
Mathur
4)Dr. Aijaz Ali Khan
5)Dr. Greesh Kumar
Singh
6)Quazi
Mateenuddin
Hameeduddin
7)Priyanka Sharma**

(57) Abstract :

The present invention relates to a compact multiple-input and multiple-output (MIMO) antenna for radar applications and method of design thereof. The objective of the present invention is to overcome the inadequacies of the prior arts compact MIMO antennas. The single antenna is used to design a MIMO antenna with two antennas where both the antennas were placed orthogonal to each other. The antennas worked independently of each other in the UWB range and also the mutual coupling between the two antennas is also very less.

No. of Pages : 19 No. of Claims : 4

(12) PATENT APPLICATION PUBLICATION

(21) Application
No.201941051401 A

(19) INDIA

(22) Date of filing of Application :12/12/2019

(43) Publication Date :
20/12/2019

(54) Title of the invention : SYSTEM AND METHOD FOR FOR AUTOMATICALLY DETECTING MALARIA

(51)
International :G06N0003040000,G01N0001280000,G06K0009620000,G06N0003080000,G06F0016338000
classification
(31) Priority
Document :NA
No
(32) Priority :NA
Date
(33) Name
of priority :NA
country
(86)
International
Application :NA
No :NA
Filing
Date
(87)
International
Publication : NA
No
(61) Patent
of Addition
to
Application :NA
Number :NA
Filing
Date
(62)
Divisional to
Application :NA
Number :NA
Filing
Date

(71)**Name of Applicant**
:
1)Dr.G.Sreenivasulu
Address of
Applicant :Associate
Professor, Department
of Computer Science
and Engineering, ACE
Engineering College,
Ankushapur,Ghatkesar
Mandal, Medchal
District Telangana
,INDIA - 501301
Telangana India
(72)**Name of Inventor :**
1)Dr.G.Sreenivasulu
2)Dr.Ganti Krishna
Sharma
3)Mr.Ch.Vijay
Kumar
4)Mr.D.Krishna
5)Dr.Krishnakumar
A
6)Dr.Pokkuluri
Kiran Sree
7)Dr.C.Thirumalai
Selvan
8)Dr.S.Balambigai
9)Dr Siva Shankar S

(57) Abstract :

Disclosed is a system and method for automatically detecting Malaria. The method includes the step of collecting a plurality of blood smear slide images in order to obtain a plurality of segmented cells through a data collection module. The blood smear slide images are normalized to a median breadth and a predefined height for a training experiment and a classification experiment. The method includes the step of utilizing a standard min-max normalization mechanism for increasing brightness and contrast of the blood smear slide images through a data pre-processing module. The method includes the step of receiving the blood smear slide images with increased brightness and contrast to train and judge a Convolution Neural Networks (CNN) model through a model training module. The trained Convolution Neural Networks (CNN) model facilitates a user to automatically detect Malaria. The most illustrative drawing: FIG. 1.

No. of Pages : 30 No. of Claims : 8

(12) PATENT APPLICATION PUBLICATION

(21) Application No.201941051423
A

(19) INDIA

(22) Date of filing of Application :12/12/2019

(43) Publication Date : 20/12/2019

(54) Title of the invention : A DEVICE FOR ANALYSING THE VARIOUS PARAMETERS ASSOCIATED WITH VEHICLE ALONG WITH ACCIDENT ALERT SYSTEM

(51)
International :G08G0001160000,B60Q0001440000,G07C0005000000,B60Q0001520000,E01F0009529000
classification
(31) Priority
Document :NA
No
(32) Priority :NA
Date
(33) Name
of priority :NA
country
(86)
International
Application :NA
No :NA
Filing
Date
(87)
International : NA
Publication
No
(61) Patent
of Addition
to
Application :NA
Number :NA
Filing
Date
(62)
Divisional to
Application :NA
Number :NA
Filing
Date

(71)Name of Applicant :
1)Dr.V.MOHANAVEL
Address of Applicant :S/o
P.VINAYAGAM Assistant Professor,
Department of Mechanical Engineering,
Chennai Institute of Technology,
Chennai - 600069, Tamil Nadu, India.
Tamil Nadu India
2)Dr. A.CHANDRASHEKAR
3)Dr. H.N.REDDAPPA
4)Dr.K.S.ASHRAFF ALI
5)Mr.S.SURESH KUMAR
6)Dr. SHAIK MASOOD AHAMED
7)Dr.P.GANESHAN
(72)Name of Inventor :
1)Dr.K.S.ASHRAFF ALI
2)Mr.S.SURESH KUMAR
3)Dr. A.CHANDRASHEKAR
4)Dr. H.N.REDDAPPA
5)Dr.V.MOHANAVEL
6)Dr. SHAIK MASOOD AHAMED
7)Dr.P.GANESHAN

(57) Abstract :

A device for analyzing the various parameters associated with vehicle along with an accident alert system is an invention that will help the owner of the vehicle to know the information about the present condition of the vehicle. This device can be either in-built or can be mounted externally to the already existing vehicles. The accident alert system will send an alert to the control room as well as to the one of the family members of the victim when that particular vehicle is met with an accident. The invention will work on Digital indication of fuel that is in milliliters, Engine oil quality and quantity Indicator, Road Barricade Indicator, Speed and time graph which records data from speedometer and Information regarding Air filter can also be detected and indicated from the device. Also the invention includes an Animal or Predator detector sensor to sense the trespassing animals as they are also major concern for road mishaps. This device also helps the driver to reduce the speed of the vehicle by detecting the speed breakers that he/she may encounter while driving. This system will provide a safer platform for the vehicle drivers since most of the important parameters are monitored by the device.

No. of Pages : 21 No. of Claims : 10

(12) PATENT APPLICATION PUBLICATION

(21) Application
No.201941051453 A

(19) INDIA

(22) Date of filing of Application :12/12/2019

(43) Publication Date :
20/12/2019

(54) Title of the invention : SMART BOX FOR SENIOR CITIZEN OR PATIENT

(51)
International :A61J0007000000,A47F0005000000,A61B0005000000,B65B0005100000,A24C0005356000
classification
(31) Priority
Document :NA
No
(32) Priority :NA
Date
(33) Name
of priority :NA
country
(86)
International
Application :NA
No :NA
Filing
Date
(87)
International : NA
Publication
No
(61) Patent
of Addition
to
Application :NA
Number :NA
Filing
Date
(62)
Divisional to
Application :NA
Number :NA
Filing
Date

(71)Name of Applicant :
**1)BHARATH
INSTITUTE OF
HIGHER EDUCATION
AND RESEARCH**
Address of Applicant
:173, Agharam Road,
Selaiyur, Chennai 600
073 Tamil Nadu India
(72)Name of Inventor :
**1)Dr. S. Philomina
2)Dr. M. Jasmin
3)K. Subbulakshmi
4)S. Saravana**

(57) Abstract :

ABSTRACT Smart box for senior citizen or patient This invention is a smart box that contains multiple trays or partitions in a single box. The trays are filled with different varieties of provisional items. According to this proposed system which is a single box with multiple trays wherein in each tray contains a single item. Each of the trays has a top closer, which is connected with a detection sensor. The box as a whole contains a microcontroller interfaced with all the sensors of the trays and an LCD display. The multiple trays are arranged in arrays inside the box and are filled with user essential items. Each tray has a detection sensor that will keep on detecting the amount of item left in the box. The microcontroller is configured to send the signals from the sensor to a smart phone using a GSM module.

No. of Pages : 7 No. of Claims : 2

(12) PATENT APPLICATION PUBLICATION

(21) Application
No.201941051454 A

(19) INDIA

(22) Date of filing of Application :12/12/2019

(43) Publication Date :
20/12/2019

(54) Title of the invention : AUTO HEALTH MONITORING COAT

(51)
International :A61B0005000000,A61B0005020500,A61B0005110000,A61B0005021000,A61N0001040000
classification
(31) Priority
Document :NA
No
(32) Priority :NA
Date
(33) Name
of priority :NA
country
(86)
International
Application :NA
No :NA
Filing
Date
(87)
International
Publication : NA
No
(61) Patent
of Addition
to
Application :NA
Number :NA
Filing
Date
(62)
Divisional to
Application :NA
Number :NA
Filing
Date

(71)**Name of Applicant**
:
**1)BHARATH
INSTITUTE OF
HIGHER
EDUCATION AND
RESEARCH**
Address of
Applicant :173,
Agharam Road,
Selaiyur, Chennai 600
073 Tamil Nadu India
(72)**Name of Inventor :**
**1)Dr. S. Philomina
2)Dr. M. Jasmin
3)K. Subbulakshmi
4)S. Saravana**

(57) Abstract :

ABSTRACT Auto health monitoring coat This invention is related to a new wearable coat which is used to monitor the health condition of patient without any need of a person nearby. Health care sensors can play an important role in hospitals and also in providing care to patients. The proposed system uses sensors to detect temperature and heartbeat. In addition, micro controller, LCD display, GPS, GSM module, are the components used to design an automatic health monitor coat. The micro controller is able to monitor the signal from the sensor and if the patient's condition becomes abnormal, the wearable coat alerts the doctor through the IoT and is also configured to send call to linked mobile number. This way we can easily monitor the patient.

No. of Pages : 6 No. of Claims : 2

(12) PATENT APPLICATION PUBLICATION

(21) Application
No.201941051455 A

(19) INDIA

(22) Date of filing of Application :12/12/2019

(43) Publication Date :
20/12/2019

(54) Title of the invention : VIRTUAL DISPLAY FOR FLOOD AFFECTED PEOPLE

(51)
International :G06F0003010000,G06F0003042000,G02B0027010000,G06F0003140000,E06B0009000000
classification
(31) Priority
Document :NA
No
(32) Priority :NA
Date
(33) Name
of priority :NA
country
(86)
International
Application :NA
No :NA
Filing
Date
(87)
International : NA
Publication
No
(61) Patent
of Addition
to
Application :NA
Number :NA
Filing
Date
(62)
Divisional to
Application :NA
Number :NA
Filing
Date

(71)Name of Applicant :
**1)BHARATH
INSTITUTE OF
HIGHER EDUCATION
AND RESEARCH**
Address of Applicant
:173, Agharam Road,
Selaiyur, Chennai 600
073 Tamil Nadu India
(72)Name of Inventor :
**1)C. Anuradha
2)S. Pothumani
3)D. Vimala
4)I. Mary Linda**

(57) Abstract :

ABSTRACT Virtual display for flood affected people This invention is a virtual reality display system based on sensor. The stored data will be automatically virtually displayed on the surface of the building and we can directly choose their essential need with the help of virtual screen. This new technology consists of micro controller and sensor. The micro controller is interfaced with input and output modules. The controller acts as intermediate micro controller can be termed as, control unit. The input module is a virtual visible screen sensor that placed at below the helicopter. Sensor or laser or beamer, is used to project visible screen onto any surface of building or flood water.

No. of Pages : 7 No. of Claims : 1

(12) PATENT APPLICATION PUBLICATION

(21) Application
No.201941051456 A

(19) INDIA

(22) Date of filing of Application :12/12/2019

(43) Publication Date :
20/12/2019

(54) Title of the invention : SPEAKING SYSTEM FOR DUMB PEOPLE

(51)
International :G09B0021000000,G09B0021040000,H04W0084040000,B25J0015000000,A41D0019000000
classification
(31) Priority
Document :NA
No
(32) Priority :NA
Date
(33) Name
of priority :NA
country
(86)
International
Application :NA
No :NA
Filing
Date
(87)
International
Publication : NA
No
(61) Patent
of Addition
to
Application :NA
Number :NA
Filing
Date
(62)
Divisional to
Application :NA
Number :NA
Filing
Date

(71)**Name of Applicant**
:
**1)BHARATH
INSTITUTE OF
HIGHER
EDUCATION AND
RESEARCH**
Address of
Applicant :173,
Agharam Road,
Selaiyur, Chennai 600
073 Tamil Nadu India
(72)**Name of Inventor :**
**1)S. Ramya
2)S. Balaji
3)G. Jeyalakshmi
4)S. Saravana**

(57) Abstract :

ABSTRACT Speaking system for dumb people This invention proposes the use of a robotic hand arm glove. This glove is used to convert sign language to regular language. This will enable easy communication for them using the sign language with which they are familiar, as the apparatus will result in output in the form of audio voice thereby enabling others to understand what the mute person is saying. This system has two wireless controllers mounted on gloves, one for each hand of the operator. This micro controller is used to control the movement of the robot arm. Here the sensor recognizes the movement of gloves and gives information to the micro controller. Robotic arm will operate based on a prestored code. An analog to digital convertor, voice processor along with micro controller, a mic and a speaker are the components used.

No. of Pages : 7 No. of Claims : 2

(54) Title of the invention : DESIGN OF IOT SYSTEM BASED ON CONTIKI OPERATING SYSTEM FOR ENGINEERING APPLICATIONS

(51)
International :H04L0029080000,G06F0008200000,G06F0008360000,G06F0008100000,G06F0008340000
classification
(31) Priority
Document :NA
No
(32) Priority :NA
Date
(33) Name
of priority :NA
country
(86)
International
Application :NA
No :NA
Filing
Date
(87)
International : NA
Publication
No
(61) Patent
of Addition
to :NA
Application :NA
Number :NA
Filing
Date
(62)
Divisional to
Application :NA
Number :NA
Filing
Date

(71)**Name of Applicant :**
1)DR. G. KALAIMANI
Address of Applicant :Professor,
Department of CSE,Shadan Women's
College of Engineering & Technology,
6-2-980, Raj Bhavan Rd, Taj Enclave,
Khairtabad, Hyderabad, Telangana
Telangana India
2)DR. C SENTHIL SINGH
3)DR. G. KAVITHA
4)DR. SUJI HELEN
5)DR. RAJA SARATH KUMAR
6)DR. RUDRESH DEEPAK
SHIRWAIKAR
7)DR. AMANDEEP KAUR
(72)**Name of Inventor :**
1)DR. G. KALAIMANI
2)DR. C SENTHIL SINGH
3)DR. G. KAVITHA
4)DR. SUJI HELEN
5)DR. RAJA SARATH KUMAR
6)DR. RUDRESH DEEPAK
SHIRWAIKAR
7)DR. AMANDEEP KAUR

(57) Abstract :

Embedded software has developed complexity for Internet of Things which is increased by the huge number of smart devices with their communication. Due to this, consequences arise such as complexity in system development, increased cost and prone to error. The invention proposes an approach for developing contiki based IoT system. Generally model of contiki includes WiFi element modules for connectivity, Components for information processing and log manager for IoT. Development of domain specific modeling environment is done using this meta model where usage of visual symbols is done with defined static semantics. Computation of components of IoT systems such as Raspberry Pi and Contiki is done by the architectural code according to model of developer's instance. Evaluation is done by using smart system for detection of fire. Development of model driven system such as sink nodes, WSN nodes, modules of WiFi components of information processing is supported by model of Contiki based IoT system.

No. of Pages : 10 No. of Claims : 6

(12) PATENT APPLICATION PUBLICATION

(21) Application
No.201941051469 A

(19) INDIA

(22) Date of filing of Application :12/12/2019

(43) Publication Date :
20/12/2019

(54) Title of the invention : HEAT EXCHANGERS WITH CIRCULAR TUBES DIVIDED INTO SECTORS FOR EFFECTIVE HEAT TRANSFER AND COMPACTNESS

(51)
International :F28D0021000000,B23P0015260000,B01J0019240000,F28F0001400000,F28D0001040000
classification

(31) Priority
Document :NA
No

(32) Priority :NA
Date

(33) Name
of priority :NA
country

(86)
International
Application :NA
No :NA

Filing
Date

(87)
International : NA
Publication
No

(61) Patent
of Addition
to
Application :NA
Number :NA
Filing

Date

(62)
Divisional to
Application :NA
Number :NA
Filing

Date

(71)**Name of Applicant :**
**1)Dr.R.SENTHIL
KUMAR**

Address of Applicant
:RESEARCH
ASSISTANT
PROFESSOR,
DEPARTMENT OF
MECHANICAL
ENGINEERING SRM
INSTITUTE OF
SCIENCE AND
TECHNOLOGY, SRM
NAGAR,
KATTANKULATHUR,
CHENNAI-603203,
TAMIL NADU, INDIA.
Tamil Nadu India

(72)**Name of Inventor :**
**1)Dr.R.SENTHIL
KUMAR**
**2)ASHWIN
MAHENDRA**

(57) Abstract :

ABSTRACT HEAT EXCHANGERS WITH CIRCULAR TUBES DIVIDED INTO SECTORS FOR EFFECTIVE HEAT TRANSFER AND COMPACTNESS The Present disclosure relates to the design of tubes used in various industrial and domestic heat exchangers. The design is suitable for applications in Power plants, vehicle radiators and thermal management systems. Traditional heat exchangers use circular tubes due to ease in manufacturing with better functional benefits. The new design described in the disclosure reveals a replacement of the circular tube with three tubes in the shape of sectors without compromising the efficiency or size of product. The new design provides better heat dissipation with the added advantage of improved compactness which results in reduced overall size.

No. of Pages : 7 No. of Claims : 3

(12) PATENT APPLICATION PUBLICATION

(21) Application
No.201941051475 A

(19) INDIA

(22) Date of filing of Application :12/12/2019

(43) Publication Date :
20/12/2019

(54) Title of the invention : DESIGN AND THERMAL HYDRAULICS ANALYSIS OF SQUARE CYLINDER FOR VARIOUS INCLINATION OF LATERAL SIDES FOR DIFFERENT CONFINEMENTS

(51)
International :H05K0007200000,H05K0005020000,B01J0029700000,H05K0001020000,H02H0003080000
classification
(31) Priority
Document :NA
No
(32) Priority :NA
Date
(33) Name
of priority :NA
country
(86)
International
Application :NA
No :NA
Filing
Date
(87)
International : NA
Publication
No
(61) Patent
of Addition
to
Application :NA
Number :NA
Filing
Date
(62)
Divisional to
Application :NA
Number :NA
Filing
Date

(71)**Name of Applicant**
:
**1)Dr. R. SENTHIL
KUMAR**
Address of Applicant
:RESEARCH
ASSISTANT
PROFESSOR,
DEPARTMENT OF
MECHANICAL
ENGINEERING, SRM
INSTITUTE OF
SCIENCE AND
TECHNOLOGY, SRM
NAGAR,
KATTANKULATHUR,
CHENNAI Tamil Nadu
India
(72)**Name of Inventor :**
**1)Dr. R. SENTHIL
KUMAR**
**2)AMIT
VARAKHEDKAR**

(57) Abstract :

The present disclosure relates to electronic components used in various industrial and domestic equipment. such as microcontrollers, microprocessor chips, temperature sensors, capacitors, heat sink, etc. The new- design described in the disclosure reveals a modification of such components with tapers on either side without compromising the efficiency or size of product. The new design offers least drag forces and pressure drop along with better heat dissipation all of which leads to economic product with better technical functionalities.

No. of Pages : 6 No. of Claims : 3

(12) PATENT APPLICATION PUBLICATION

(21) Application
No.201941051521 A

(19) INDIA

(22) Date of filing of Application :12/12/2019

(43) Publication Date :
20/12/2019

(54) Title of the invention : TREATMENT OF DOMESTIC WASTE WATER USING GEOTEXTILE AS FILTER MEDIA

(51)
International :C02F0001280000,B01D0039160000,C02F0001000000,B01J0020060000,B01D0024460000
classification
(31) Priority
Document :NA
No
(32) Priority :NA
Date
(33) Name
of priority :NA
country
(86)
International
Application :NA
No :NA
Filing
Date
(87)
International
Publication : NA
No
(61) Patent
of Addition
to
Application :NA
Number :NA
Filing
Date
(62)
Divisional to
Application :NA
Number :NA
Filing
Date

(71)**Name of Applicant :**
1)PRINCIPAL,
DAYANANDA SAGAR
ACADEMY OF
TECHNOLOGY AND
MANAGEMENT
Address of Applicant
:DAYANANDA SAGAR
ACADEMY OF
TECHNOLOGY AND
MANAGEMENT,
UDAYAPURA,
KANAKAPURA ROAD,
OPPOSITE TO ARTS OF
LEAVING,
BANGALORE-560082,
KARNATAKA, INDIA.
Karnataka India
(72)**Name of Inventor :**
1)SHREYAS B V
2)YATHISH B R.
3)VINAYAKA B
4)SANJAY D

(57) Abstract :

Geotextile is a manufactured fabric made of various polymer mix and it has unique character of holding suspended solids. Geotextile has a capacity to extended life time of intermediale sand filter by inability the accumulation of surface of it and also reliability and performance of traditional graded soil filter and easy to construct. The main objective of this study was to investigate and develop the fikrat ion performance of normally selected locally available waste clothing material as a Geotextile media. The laboratory portion of the study includes column test with alternating layers of filter media consisting of sand, gravel and. This was investigated for domestic waste water collected and pilot scale tests in a designed reactor of column scale studies. From the obtained results it can be concluded that 150GSM Geotextile has the high removal efficiency capacity for removing various parameters. Normal cloth material also showed has the high removal efficiency capacity for removing various parameters compare to non oven Geotextile.

No. of Pages : 20 No. of Claims : 4

(12) PATENT APPLICATION PUBLICATION

(21) Application
No.201941051524 A

(19) INDIA

(22) Date of filing of Application :12/12/2019

(43) Publication Date :
20/12/2019

(54) Title of the invention : IN-SILICO ANALYSIS OF INHIBITORY ACTION OF BETA SITOSTEROL FROM PLANT SOURCE AGAINST PHOSPHOLIPASE A2 IN SNAKE VENOM

(51)
International :A61K0039395000,C12N0009200000,C07K0014435000,C07K0016180000,A61K003846000
classification

(31) Priority
Document :NA
No

(32) Priority :NA
Date

(33) Name
of priority :NA
country

(86)
International
Application :NA
No :NA

Filing
Date

(87)
International
Publication : NA
No

(61) Patent
of Addition
to
Application :NA
Number :NA

Filing
Date

(62)
Divisional to
Application :NA
Number :NA

Filing
Date

(71)Name of Applicant
:
**1)Mr. VEERAPANDI
L**

Address of Applicant
:DEPARTMENT OF
FOOD TECHNOLOGY,
BANNARI AMMAN
INSTITUTE OF
TECHNOLOGY,
SATHYAMANGALAM
, ERODE (DT),
TAMILNADU-638401
Tamil Nadu India

(72)Name of Inventor :
**1)Mr. VEERAPANDI
L**
2)Mrs. R. SINTHIYA
3)Ms. NIVETHA

(57) Abstract :

The prevalence of high mortality rate due to snake bite is widely found in Indian farmlands, as most of the poisonous snake varieties are found in the farm areas. Although much antivenom like antivenin has been formulated to treat snake bite, they have limitations like high cost and difficulties in storage. Also most of the deaths are majorly due to the time delay in treating the snakebite. The venom activity or the poisonous nature of the venom has been identified because of the enzymes such as Phospholipase A2, hyaluronidase and protease enzyme. As a solution for this problem, the active site of these enzymes can be elucidated and inhibited using extracts from plants and food source through insilico studies. It has been suggested that Beta sitosterol in plant sources have high inhibition activity against PLA2. In silico molecular docking and molecular dynamics simulation is proposed to be performed between Beta sitosterol and Phospholipase A2 (1BK9) to understand the conformational changes and to analyze the best binding pocket.

No. of Pages : 6 No. of Claims : 12

(12) PATENT APPLICATION PUBLICATION

(21) Application
No.201941051560 A

(19) INDIA

(22) Date of filing of Application :12/12/2019

(43) Publication Date :
20/12/2019

(54) Title of the invention : ASSD-PLANTER: AUTOMATIC SPRAYING SEEDS DISPENSED FROM A PLANTER.

(51)
International:A01C0007100000,A01C0007060000,A01C0007120000,A01C0021000000,A01C00230000
classification 00

(31) Priority
Document :NA
No

(32) Priority :NA
Date

(33) Name
of priority :NA
country

(86)
International
Application :NA
No :NA

Filing
Date

(87)
International
Publication : NA
No

(61) Patent
of Addition
to
Application :NA
Number :NA

Filing
Date

(62)
Divisional
to
Application :NA
Number :NA

Filing
Date

(71)**Name of Applicant :**
1)DR. SIVAKANDHAN C
Address of Applicant
:SRI INDU INSTITUTE
OF ENGINEERING AND
TECHNOLOGY,
SHERIGUDA,
IBRAHIMPATNAM
501510, HYDERABAD,
INDIA PAN :
BOJPS7903A, Mobile No.
+919443495945 Email :
kandhansiva69@gmail.co
m Telangana India

**2)DR. A R PRADEEP
KUMAR**

3)DR. SENTHUR N S

4)MR. S.

BALAMURUGAN

**5)MR. H. IMAMUL
HASAN**

**6)MR. M.MAHESH
KUMAR**

(72)**Name of Inventor :**
1)DR. SIVAKANDHAN C

**2)DR. A R PRADEEP
KUMAR**

3)DR. SENTHUR N S

4)MR. S.

BALAMURUGAN

**5)MR. H. IMAMUL
HASAN**

**6)MR. M.MAHESH
KUMAR**

(57) Abstract :

ABSTRACT ASSD-Planter: AUTOMATIC SPRAYING SEEDS DISPENSED FROM A PLANTER. My Invention ASSD-Planter • In one aspect, a system for providing seed-specific placement of fluid as seeds are planted by a planter is disclosed. The system may generally include a seed meter configured to dispense seeds into a furrow at a seed frequency and a nozzle assembly configured to spray the seeds dispensed into the furrow. The nozzle assembly may include a valve. In addition, the system may include a controller communicatively coupled to the valve. The controller may be configured to determine the seed frequency of the seed meter based on a speed-related parameter of the planter. The controller may also be configured to control the operation of the valve based on the seed frequency such that a metered amount of fluid is sprayed at least one of on or adjacent to each seed.

No. of Pages : 24 No. of Claims : 5

(54) Title of the invention : IOT SENSORS BASED MULTI-FUNCTIONAL AND INTELLIGENT WALK GUIDING STICK FOR VISUAL DISABLED PERSON

(51)
International :A61H0003060000,H04W0004700000,H04W0004020000,G06F0003010000,H04L0029080000
classification
(31) Priority
Document :NA
No
(32) Priority :NA
Date
(33) Name
of priority :NA
country
(86)
International
Application :NA
No :NA
Filing
Date
(87)
International
Publication :NA
No
(61) Patent
of Addition
to :NA
Application :NA
Number :NA
Filing
Date
(62)
Divisional to
Application :NA
Number :NA
Filing
Date

(71)Name of Applicant :
1)DR. PRABHAKAR KANDUKURI
Address of Applicant :PROFESSOR ,
DEPARTMENT OF COMPUTER SCIENCE AND
ENGINEERING , VARDHAMAN COLLEGE OF
ENGINEERING, HYDERABAD, DIST.
TELENGANA, INDIA Telangana India
2)DR. SUBHENDU KUMAR PANI
3)DR. AJAY B GADICHA
4)DR. S. K. DHAKAD
5)PARNAL PRAKASH PAWADE
6)DR. K. PRASAD
7)DR.G. SURYA NARAYANA
8)DR. SURESH KALLAM
9)DR. ANAMIKA AHIRWAR
10)PROF. POOJA SHUKLA
(72)Name of Inventor :
1)DR. PRABHAKAR KANDUKURI
2)DR. SUBHENDU KUMAR PANI
3)DR. AJAY B GADICHA
4)DR. S. K. DHAKAD
5)PARNAL PRAKASH PAWADE
6)DR. K. PRASAD
7)DR.G. SURYA NARAYANA
8)DR. SURESH KALLAM
9)DR. ANAMIKA AHIRWAR
10)PROF. POOJA SHUKLA

(57) Abstract :

The present invention relates to the internet of things (IoT) sensor based multi-functional and intelligent walk guiding stick for visual disable person the objective of the present invention is to overcome the inadequacies of the prior arts in the walk guiding stick for visual disable person. The presented walking stick may used for making way for blind person using sensors and other IoT tools integrated in it.

No. of Pages : 18 No. of Claims : 6

(12) PATENT APPLICATION PUBLICATION

(21) Application
No.201941051643 A

(19) INDIA

(22) Date of filing of Application :12/12/2019

(43) Publication Date :
20/12/2019

(54) Title of the invention : VOICE CONTROLLED WHEEL CHAIR FOR HANDICAPPED PEOPLE

(51)
International :A61G0005100000,A61G0005120000,G10L0015260000,A61G0005060000,G10L0015220000
classification
(31) Priority
Document :NA
No
(32) Priority :NA
Date
(33) Name
of priority :NA
country
(86)
International
Application :NA
No :NA
Filing
Date
(87)
International
Publication : NA
No
(61) Patent
of Addition
to
Application :NA
Number :NA
Filing
Date
(62)
Divisional to
Application :NA
Number :NA
Filing
Date

(71)**Name of Applicant**
:
**1)BHARATH
INSTITUTE OF
HIGHER
EDUCATION AND
RESEARCH**
Address of
Applicant :173,
Agharam Road,
Selaiyur, Chennai 600
073 Tamil Nadu India
(72)**Name of Inventor :**
1)K. Sakthivel
2)R.Rathika
3)S. Aarthi Suriya

(57) Abstract :

ABSTRACT Voice controlled wheel chair for handicapped people. This invention is directed towards a voice operated wheel chair that can be commanded to move in a desired direction or to stop based on voice commands. The commands from user are issued through a mic, which is then processed further by a voice recognition module, which is interfaced with a micro controller. The voice recognition module is used to understand the command to control the movement of wheel chair. The microcontroller appropriately directs the drivers to execute the rotation of DC motor to rotate the wheels of chair in particular direction or to stop. Power required for the operation is provided by an onboard rechargeable battery system. Additionally, an ultrasonic sensor is used to find the hurdles in between wheelchair and the way of direction. A motor driver is used to interface between micro controller and DC motor.

No. of Pages : 7 No. of Claims : 2

(12) PATENT APPLICATION PUBLICATION

(21) Application
No.201941051644 A

(19) INDIA

(22) Date of filing of Application :12/12/2019

(43) Publication Date :
20/12/2019

(54) Title of the invention : WIRELESS FLY LIGHT

(51)
International :H02J0007020000,H02J0050120000,H04B0005000000,H01F0038140000,H02J0050800000
classification
(31) Priority
Document :NA
No
(32) Priority :NA
Date
(33) Name
of priority :NA
country
(86)
International
Application :NA
No :NA
Filing
Date
(87)
International
Publication : NA
No
(61) Patent
of Addition
to
Application :NA
Number :NA
Filing
Date
(62)
Divisional to
Application :NA
Number :NA
Filing
Date

(71)Name of Applicant :
**1)BHARATH
INSTITUTE OF
HIGHER EDUCATION
AND RESEARCH**
Address of Applicant
:173, Agharam Road,
Selaiyur, Chennai 600 073
Tamil Nadu India
(72)Name of Inventor :
**1)Dr. S. Prakash
2)Dr. V. Jayalakshmi
3)Dr. S.P. Vijaya
Ragavan
4)Anitha Sampath
Kumar**

(57) Abstract :

ABSTRACT Wireless fly light This invention proposes a wireless fly lamp. Here we use electromagnetic, wireless power transmitter, receiver, and wooden enclosure, low energy LED light or shatterproof bulb to design a wireless fly light. Wireless power transfer transmission is used here. The Fly light or fly lamp provides illumination that combines the wonders of magnetic levitation with wireless power. The annexed figure explains the primary coil and secondary coil that are interfaced together through the air medium.

No. of Pages : 6 No. of Claims : 2

(12) PATENT APPLICATION PUBLICATION

(21) Application
No.201941051645 A

(19) INDIA

(22) Date of filing of Application :12/12/2019

(43) Publication Date :
20/12/2019

(54) Title of the invention : ALERT AND IDENTIFICATION OF ACCIDENT

(51)
International :G08G0001000000,G08G0001160000,G08B0003100000,G08G0001096800,G07C0005000000
classification
(31) Priority
Document :NA
No
(32) Priority :NA
Date
(33) Name
of priority :NA
country
(86)
International
Application :NA
No :NA
Filing
Date
(87)
International : NA
Publication
No
(61) Patent
of Addition
to
Application :NA
Number :NA
Filing
Date
(62)
Divisional to
Application :NA
Number :NA
Filing
Date

(71)Name of Applicant
:
**1)BHARATH
INSTITUTE OF
HIGHER
EDUCATION AND
RESEARCH**
Address of
Applicant :173,
Agharam Road,
Selaiyur, Chennai 600
073 Tamil Nadu India
(72)Name of Inventor :
**1)Dr. S.
Thirumavalavan
2)V. Srinivasan
3)R.J. Golden
Renjith Nimal
4)Dr. J. Hameed
Hussain**

(57) Abstract :

ABSTRACT Alert and identification of accident This invention is an accident identification system that gathers and sends details of the accident, including vehicles involved in the accident, time and place of the accident to the control room. Here we use RF transmitter, micro controller, RF receiver, vibration sensors, LCD display, GPS module to design an accident alerting system. The user vehicle is fixed with those components for identifying the accident. If the user vehicle gets involved in any accident, then the vibration sensor detects this and sends a signal to the micro controller. An onboard GPS module provides the exact location details to the microcontroller. The micro controller sends these signals to an RF transmitter, which in turn begins transmitting this accident information to nearest control room. RF receiver located in the control room reads this signal and then the information is displayed on a display device such as an LCD screen.

No. of Pages : 8 No. of Claims : 3

(12) PATENT APPLICATION PUBLICATION

(21) Application
No.201941051669 A

(19) INDIA

(22) Date of filing of Application :13/12/2019

(43) Publication Date :
20/12/2019

(54) Title of the invention : AN ELECTRONIC CIRCUIT BASED POWER CONSUMPTION MONITORING SYSTEM

(51)
International :G06Q0050060000,G06F0015780000,G06F0001320600,H02J0003240000,G06Q0030040000
classification
(31) Priority
Document :NA
No
(32) Priority :NA
Date
(33) Name
of priority :NA
country
(86)
International
Application :NA
No :NA
Filing
Date
(87)
International
Publication : NA
No
(61) Patent
of Addition
to
Application :NA
Number :NA
Filing
Date
(62)
Divisional to
Application :NA
Number :NA
Filing
Date

(71)**Name of Applicant :**
1)Miranji Katta
Address of Applicant
:S/o Krishna Murthy
D.no: 3-329, kattavari
street, Veeravasaram
(MD&PO), West
Godavari District,
Andhra Pradesh -534245,
India Andhra Pradesh
India
(72)**Name of Inventor :**
1)Miranji Katta
2)Rapaka Sathish
3)Ram Kumar
Adireddi
4)Trinadh Rajanala

(57) Abstract :

ABSTRACT: Title: An Electronic Circuit based Power Consumption Monitoring System The present disclosure discloses a portable, compact and economical electronic circuit built internally to any power consumed product aids to observe the safe and replace time of the product as per indicators. The electronic circuit based power consumption monitoring system 100 comprises an input means 101, a graphical interface means 102, and a power indicating means 103. The system 100 aids to indicate a green LED if the product consumes specified power as per entered specified power consumption limit and indicates a red LED if the product consumes more power than its specification or if the product is not working. Such an eco-friendly circuit aids to reduce excess power consumption thereby enhancing the awareness among people.

No. of Pages : 14 No. of Claims : 7

(12) PATENT APPLICATION PUBLICATION

(21) Application
No.201941051671 A

(19) INDIA

(22) Date of filing of Application :13/12/2019

(43) Publication Date :
20/12/2019

(54) Title of the invention : OPTIMISED FORGING OF FRONT AXLE BEAMS

(51)
International :B21J0005020000,B21J0005000000,B60B0035080000,B21K0029000000,B21D0005020000
classification
(31) Priority
Document :NA
No
(32) Priority :NA
Date
(33) Name
of priority :NA
country
(86)
International
Application :NA
No :NA
Filing
Date
(87)
International
Publication : NA
No
(61) Patent
of Addition
to
Application :NA
Number :NA
Filing
Date
(62)
Divisional to
Application :NA
Number :NA
Filing
Date

(71)**Name of Applicant :**
**1)M M Forgings
Limited**
Address of Applicant
:SVK Towers, A25, 8th
Floor, Industrial Estate,
Guindy, Chennai Tamil
Nadu India
(72)**Name of Inventor :**
**1)K.Kaviyarasu
2)M.Nagarajan
3)Vidyashankar
Krishnan
4)B.Gautaman
5)R.Karthikeyan**

(57) Abstract :

Title: Optimised Forging of Front Axle Beams The present disclosure discloses a Slim Reduce Rolling (Slim RR) with optimised forging of front axle beam (FAB). The optimised forging process of front axle beam (FAB) comprises reduce rolling in two passes with bending on a press external to the Main Forging Equipment (MFE) and two stage forging in the Main Forging Equipment (MFE) of 8000T with suitable die design that reduces forging load and cycle time to less than 30 seconds. Thus, the optimised forging process provides improved productivity of the forging process using line balancing.

No. of Pages : 17 No. of Claims : 4

(12) PATENT APPLICATION PUBLICATION

(21) Application
No.201941051673 A

(19) INDIA

(22) Date of filing of Application :13/12/2019

(43) Publication Date :
20/12/2019

(54) Title of the invention : SYSTEM AND METHOD FOR IMAGE COMPRESSION TO REDUCE CO2 EMISSIONS OVER IOT

(51)
International :H04N0019156000,C21B0007000000,H04N0019426000,H04S0005000000,A61B0018000000
classification
(31) Priority
Document :NA
No
(32) Priority :NA
Date
(33) Name
of priority :NA
country
(86)
International
Application :NA
No :NA
Filing
Date
(87)
International
Publication : NA
No
(61) Patent
of Addition
to
Application :NA
Number :NA
Filing
Date
(62)
Divisional to
Application :NA
Number :NA
Filing
Date

(71)**Name of Applicant**
:
1)Koduru Suresh
Address of Applicant
:S/o K.S.R.Krishna
D.No:9-5-65,
L.B.Colony(Post),
Visakhapatnam Andhra
Pradesh India
(72)**Name of Inventor :**
1)Koduru Suresh
2)Padala Preethi
3)Padala Pushkal

(57) Abstract :

Title: System and Method for Image Compression to Reduce CO2 Emissions over IoT The present disclosure discloses a system and method for image compression to reduce CO2 emissions over IoT. The system comprises a cooler space transforming means 101, a block splitting means 102, a discrete cosine transforming means 103, a grey wolf optimization means 104, a zig-zag scanning means 105, an emission calculation means 106. The proposed system modifies JPEG baseline compression by incorporating grey wolf optimizer. The system provides green Internet of Things (IoT) for enterprises using grey wolf optimizer for Information and Communication Technology (GWOICT). The system reduces the volume of the data exchanged in Information and Communication Technology (ICT) while maintaining the quality. The system reduces the bandwidth required for image transmission and the overall energy consumption to thereby reduce the carbon footprint of Information and Communication Technology (ICT).

No. of Pages : 15 No. of Claims : 4

(12) PATENT APPLICATION PUBLICATION

(21) Application
No.201941051678 A

(19) INDIA

(22) Date of filing of Application :13/12/2019

(43) Publication Date :
20/12/2019

(54) Title of the invention : FRAUD DETECTION SYSTEM FOR CREDIT AND DEBIT CARD HOLDERS

(51)
International:G06F0021310000,G07F0007080000,G06Q0020040000,G06Q0020400000,G06Q00202000
classification 00

(31) Priority
Document :NA
No

(32) Priority :NA
Date

(33) Name
of priority :NA
country

(86)
International
Application :NA
No :NA

Filing
Date

(87)
International
Publication : NA
No

(61) Patent
of Addition
to
Application :NA
Number :NA

Filing
Date

(62)
Divisional
to
Application :NA
Number :NA

Filing
Date

(71)Name of Applicant :
**1)BHARATH
INSTITUTE OF
HIGHER EDUCATION
AND RESEARCH**
Address of Applicant
:173, Agharam Road,
Selaiyur, Chennai 600 073
Tamil Nadu India
(72)Name of Inventor :
**1)Dr.M.Senthilkumar
2)Dr.K.P.Kaliyamurthi
3)Dr.G.Michael
4)C.Anuradha
5)K.Sivaraman**

(57) Abstract :

Fraud detection system for credit and debit card holders This invention is a fraud detection system for checking transaction of debit and credit card holders. Each Individual transaction is submitted to this system for verification. This system receives the card details and the value of purchase to verify. Here the system uses user behavior and location scanning to check for unusual patterns. These patterns include user characteristics such as user spending pattern as well as usual user geographic location to verify. In case any unusual pattern is detected the system requires recertification. Based upon previous data of that user the system recognizes unusual patterns in the payment procedure. So now the system may require the user to login again or even block the user for more than 3 invalid attempts.

No. of Pages : 5 No. of Claims : 1

(54) Title of the invention : DESIGNING AND CONTROLLING OF ELECTRO HYDRAULIC BRAKING SYSTEM WITH ENHANCED PERFORMANCE

(51) International :B60L0007260000,B60T0001100000,B60L0015200000,B60W0040068000,B60L0007180000 classification
 (31) Priority Document :NA
 No
 (32) Priority Date :NA
 (33) Name of priority :NA
 country
 (86) International Application :NA
 No :NA
 Filing Date
 (87) International Publication :NA
 No
 (61) Patent of Addition to Application :NA
 Number :NA
 Filing Date
 (62) Divisional to Application :NA
 Number :NA
 Filing Date

(71)Name of Applicant :
1)Dr.V.Jayaseelan Professor, Mechanical
 Address of Applicant :Prathyusha Engineering College, Aranvoyaluppam, Poonamallee- Thiruvallur Road, Thiruvallur Tamil Nadu India
2)Dr.D.Jayabalakrishnan Associate Professor, Mechanical
3)Dr.J. Francis Xavier Professor, Mechanical
4)Dr.R.Ashok Gandhi Associate Professor, Mechanical
5)Dr. A. Mathivanan Associate Professor
6)Mr.P.Vignesh Assistant Professor, Mechanical
7)Dr.A. Sivakumar Professor, Mechanical
8)Mr.S.Dhanasekar Assistant professor, Mechanical
 (72)Name of Inventor :
1)Dr.V.Jayaseelan Professor, Mechanical
2)Dr.D.Jayabalakrishnan Associate Professor, Mechanical
3)Dr.J. Francis Xavier Professor, Mechanical
4)Dr.R.Ashok Gandhi Associate Professor, Mechanical
5)Dr. A. Mathivanan Associate Professor
6)Mr.P.Vignesh Assistant Professor, Mechanical
7)Dr.A. Sivakumar Professor, Mechanical
8)Mr.S.Dhanasekar Assistant professor, Mechanical

(57) Abstract :

Architecture of current braking system of fully electrical vehicles and hybrid electric vehicles adopt the solution of X by wire such as electro mechanical braking and electro hydraulic braking which aim to provide flexible distinctive functions additionally of blending of brake and regeneration. Conventional frictional brakes still supports the regenerative brakes due to the occurrence of failures, condition of full charge battery and difference in the friction coefficient of the tire road. Monitoring of coefficient of friction of brake linings is necessary for coordinative action between conventional frictional brakes and regenerative frictional brakes. This invention involves the estimation of Brake lining coefficient of friction using an approach model less tire. The method does not depend on modelization of any fixed tire which has variations in state estimation with uncertainties in the characteristics of the friction. Electric vehicle with motors onboard is tested with the EHB with various levels of deceleration for wet and dry surfaces. Variation in compensation function of BLCF is noted for controller the braking of electric vehicle.

No. of Pages : 14 No. of Claims : 7

(12) PATENT APPLICATION PUBLICATION

(21) Application
No.201941051792 A

(19) INDIA

(22) Date of filing of Application :13/12/2019

(43) Publication Date :
20/12/2019

(54) Title of the invention : MACHINE LEARNING BASED GUIDING SYSTEM FOR VISUAL IMPAIRED PERSON

(51)
International :A61H0003060000,H04B0007060000,G06N0020000000,G08B0007060000,G09B0005020000
classification
(31) Priority
Document :NA
No
(32) Priority :NA
Date
(33) Name
of priority :NA
country
(86)
International
Application :NA
No :NA
Filing
Date
(87)
International : NA
Publication
No
(61) Patent
of Addition
to
Application :NA
Number :NA
Filing
Date
(62)
Divisional to
Application :NA
Number :NA
Filing
Date

(71)Name of Applicant
:
**1)Dr. V. B.
Narasimha**
Address of
Applicant :Assistant
Professor, Department
of Computer Science
and Engineering,
University College of
Engineering, Osmania
University, Hyderabad
Telangana India
**2)Naganaboina
Krishna Veni**
3)Dr. S. Nagaprasad
(72)Name of Inventor :
**1)Dr. V. B.
Narasimha**
**2)Naganaboina
Krishna Veni**
3)Dr. S. Nagaprasad

(57) Abstract :

The present invention relates to a machine learning based guiding system for visual impaired person. The objective of the present invention is to overcome the inadequacies of the prior arts in the guiding system for visual disable person. The system for guiding a visual impaired person comprises a smart eyeglass, a foldable walk guiding stick, a voice module, a training module and a central processing unit.

No. of Pages : 18 No. of Claims : 6

(12) PATENT APPLICATION PUBLICATION

(21) Application No.201941051826
A

(19) INDIA

(22) Date of filing of Application :13/12/2019

(43) Publication Date : 20/12/2019

(54) Title of the invention : AUTOMATIC FIRE FIGHTING ROBOT WITH SMART CAMERA

(51)

International :A62C0099000000,G06F0017500000,G05B0019420000,A62C0037360000,A62C0035680000
classification

(31) Priority

Document :NA
No

(32) Priority :NA
Date

(33) Name
of priority :NA
country

(86)

International
Application :NA
No :NA

Filing
Date

(87)

International : NA
Publication
No

(61) Patent
of Addition
to
Application :NA
Number :NA

Filing
Date

(62)

Divisional to
Application :NA
Number :NA

Filing
Date

(71)Name of Applicant :

1)J.Pechimuthu

Address of Applicant :UG Student,
Department of Mechanical Engineering,
Sri Krishna College of Engineering and
Technology, Kuniamuthur, Coimbatore.
Tamil Nadu India

2)P.Ashoka Varthanan

3)G.Dinesh

4)D.T.Nandeesh

5)S.Vignesh

6)R.Ramamoorthi

7)V.S.Navin Karthi

8)R.Nitin Vyas

9)P.Dineshkumar

10)D.Divaaakar

11)M.Arvind

12)N.Ramachandran

13)R.Siva Subramanian

(72)Name of Inventor :

1)N.Ramachandran

2)D.Divaaakar

3)S.Vignesh

4)M.Arvind

5)J.Pechimuthu

6)V.S.Navin Karthi

7)G.Dinesh

8)D.T.Nandeesh

9)P.Dineshkumar

10)R.Siva Subramanian

11)R.Nitin Vyas

12)P.Ashoka Varthanan

13)R.Ramamoorthi

(57) Abstract :

The main aim of our Project is to develop a model of firefighting robot to reduce the manual effort and also reducing the risk and heavy fire injuries of the manual fire fighters. This proto type model is fully automatic working with the sensor, dc motors and the control unit. It is a hardware model based on circuits, that automatically extinguishes the fire during accidents. This robot moves in the direction with respect to the fire intensity detects fire captures image of the place of fire incident and sends the same to a predefined mail id which gives us a first view of incident and actuates the extinguishing mechanism to put off the fire.

No. of Pages : 5 No. of Claims : 6

(12) PATENT APPLICATION PUBLICATION

(21) Application
No.201941051935 A

(19) INDIA

(22) Date of filing of Application :14/12/2019

(43) Publication Date :
20/12/2019

(54) Title of the invention : SYNTHESIS AND CHARACTERIZATION OF HYBRID Cu-SiO₂ NANOPARTICLES IN WATER-GLYCERIN BASE LIQUIDS FOR HEAT TRANSFER APPLICATIONS

(51) International :C09K0005100000,G01N0025180000,F28D0001020000,A61K0009000000,F28D0015000000
classification

(31) Priority
Document :NA
No

(32) Priority :NA
Date

(33) Name
of priority :NA
country

(86) International
Application :NA
No :NA

Filing
Date

(87) International : NA
Publication
No

(61) Patent
of Addition
to Application :NA
Number :NA

Filing
Date

(62) Divisional to
Application :NA
Number :NA

Filing
Date

(71)Name of Applicant
:

**1)Mrs. M L R
Chaitanya Lahari**
Address of Applicant
:Research Scholar,
School of Mechanical
Engineering, REVA
University, Rukmini
Knowledge Park,
Kattigenahalli ,
Yelahanka, Bangalore
560064 Karnataka India

**2)Dr. K.S.
Narayanaswamy**
**3)Dr. P H V Sessa
Talpa Sai**

**4)Dr. Ajith Raj R
5)Mr. G. Dheeraj
Kumar**

(72)Name of Inventor :

**1)Mrs. M L R
Chaitanya Lahari**
**2)Dr. K.S.
Narayanaswamy**

**3)Dr. P H V Sessa
Talpa Sai**
**4)Dr. Ajith Raj R
5)Mr. G. Dheeraj
Kumar**

(57) Abstract :

The invention relates to hybrid nanoparticles of Cu@SiO₂ mixed in different proportions (hybrid) in water Glycerin base liquid and estimation of dispersion behavior, determination of the effective thermal conductivity and viscosity and the estimation of forced convection heat transfer coefficients undertaken which are useful in the design of heat exchangers. The fundamental knowledge of the interactions of various parameters due to enhanced nanofluid thermal conductivity by 25% is useful in size reduction by 8 - 12% and consequently the cost of an automobile radiator and heat exchangers. In the present invention a method for heat transfer augmentation, said method comprises:(a) Preparing nanoparticles of Cu; (b) synthesizing of SiO₂ nanoparticles; (c) Preparing Cu-SiO₂ hybrid particles from said nanoparticles of Cu and said SiO₂ nanoparticles; and(d) Synthesizing of stable hybrid nanofluids of said Cu- SiO₂ hybrid particles in Water-Glycerin base liquid is disclosed.

No. of Pages : 17 No. of Claims : 7

(12) PATENT APPLICATION PUBLICATION

(21) Application
No.201941051953 A

(19) INDIA

(22) Date of filing of Application :14/12/2019

(43) Publication Date :
20/12/2019

(54) Title of the invention : SYSTEM AND METHOD BASED ON UNMANNED AERIAL VEHICLE TO DETECT FOREST FIRE

(51)
International
Classification
:A62C0003020000,G08B0017120000,G08B0017000000,B64C0039020000,G06F002185
0000

(31) Priority
Document :NA
No

(32) Priority
Date :NA

(33) Name
of priority :NA
country

(86)
International
Application :NA
No :NA

Filing
Date

(87)
International
Publication : NA
No

(61) Patent
of Addition
to :NA
Application :NA
Number

Filing
Date

(62)
Divisional
to :NA
Application :NA
Number

Filing
Date

(71)Name of Applicant :
1)Dr.S.Sudhakar
Address of Applicant
:Professor, Dept. of CSE, Sri
Shakthi Institute of
Engineering And
Technology, Coimbatore-
641062, Tamil Nadu, India
Tamil Nadu India
**2)Dr.V.Subramaniaswa
my**
3)Dr.E.Punarselvam
4)Dr.S.Balamurugan
5)Dr.S.Murugan
6)Dr.R.Vasanthi
7)Dr.P.Madhubala
8)Dr. M.Rajesh Babu

(72)Name of Inventor :
1)Dr.S.Sudhakar
**2)Dr.V.Subramaniaswa
my**
3)Dr.E.Punarselvam
4)Dr.S.Balamurugan
5)Dr.S.Murugan
6)Dr.R.Vasanthi
7)Dr.P.Madhubala
8)Dr. M.Rajesh Babu

(57) Abstract :

This invention focusses on developing a system and method to detect false alarms in Forest Fires. One of the primary reason for ecological degradation is the occurrence of Forest Fires. This invention employs an Unmanned Aerial Vehicle(UAV) aeronautical picture information, for remote watching of occurrence of flame in forests. The source of fire, choice of cause of fire are taken as parameters for color code identification, smoke motion recognition and for classifying the fire type and intensity. The present invention describes strategies for flame division invisible cameras and a system to blend the acquired intelligent data. Extended steps are invented and applied in forest fire recognition algorithms for correct functioning of UAVs. The system efficiently detects false positive alarms in forest fires.

No. of Pages : 25 No. of Claims : 4

(12) PATENT APPLICATION PUBLICATION

(21) Application
No.201941051954 A

(19) INDIA

(22) Date of filing of Application :14/12/2019

(43) Publication Date :
20/12/2019

(54) Title of the invention : AN IMPROVED INTERNAL CURING CONCRETE COMPOSITION WITH LWA AND A PROCESS OF PREPARATION THEREOF

(51)
International :C04B0028020000,C04B0028040000,B29C0033600000,H01M0010058000,G01N0033380000
classification

(31) Priority
Document :NA
No

(32) Priority :NA
Date

(33) Name
of priority :NA
country

(86)
International
Application :NA
No :NA

Filing
Date

(87)
International : NA
Publication
No

(61) Patent
of Addition
to
Application :NA
Number :NA

Filing
Date

(62)
Divisional to
Application :NA
Number :NA

Filing
Date

(71)Name of Applicant

**1)Vel Tech
Rangarajan Dr.
Sagunthala R&D
Institute of Science
and Technology**
Address of
Applicant :No.42, Avadi
Vel Tech Road, Avadi,
Chennai - 600 062
Tamil Nadu, India
Tamil Nadu India

(72)Name of Inventor :

1)S.Sivaranjani

(57) Abstract :

AN IMPROVED INTERNAL CURING CONCRETE COMPOSITION WITH LWA AND A PROCESS OF PREPARATION THEREOF The present invention relates to an improved internal curing technique for M40 grade concrete mixture. The mechanical characteristics of concrete such as compressive strength, load deflection strength and stress-strain behavior by varying the different percentage of Light Weight Aggregates by weight of cement in mixture for M40 grade concrete using internal curing technique has been experimentally done and was observed.

No. of Pages : 40 No. of Claims : 2

(12) PATENT APPLICATION PUBLICATION

(21) Application
No.201941051955 A

(19) INDIA

(22) Date of filing of Application :14/12/2019

(43) Publication Date :
20/12/2019

(54) Title of the invention : SECURITY SURVEILLANCE SYSTEM

(51)
International :H04N0007180000,G08B0013196000,H04W0004900000,H04M0011040000,G08B0013000000
classification

(31) Priority
Document :NA
No

(32) Priority
Date :NA

(33) Name
of priority :NA
country

(86)
International
Application :NA
No :NA

Filing
Date

(87)
International
Publication : NA
No

(61) Patent
of Addition
to
Application :NA
Number :NA

Filing
Date

(62)
Divisional to
Application :NA
Number :NA
Filing
Date

(71)Name of
Applicant :
1)Vel Tech
Rangarajan Dr.
Sagunthala R&D
Institute of Science
and Technology
Address of
Applicant :No.42,
Avadi Vel Tech Road,
Avadi, Chennai - 600
062 Tamil Nadu, India
Tamil Nadu India
(72)Name of Inventor
:
1)Dr. Pavithra. E
2)Arivukkarasan. R

(57) Abstract :
SECURITY SURVEILLANCE SYSTEM The present invention relates to a security surveillance system using raspberry pi. The setup installation of the system is very simple and can be done within less time. This may reduce the lead-time of respective security agencies to identify the root cause and resolve the emergency situation, because of which the victim can be out of danger within considerable amount of time Main illustrative figure is Fig:1

No. of Pages : 10 No. of Claims : 2

(12) PATENT APPLICATION PUBLICATION

(21) Application
No.201941051956 A

(19) INDIA

(22) Date of filing of Application :14/12/2019

(43) Publication Date :
20/12/2019

(54) Title of the invention : ADVANCED INTAKE SYSTEM FOR AN INTERNAL COMBUSTION ENGINE

(51)
International :F02D0013020000,F02D0041000000,F02B0027020000,F02B0075220000,F02B0025140000
classification

(31) Priority
Document :NA
No

(32) Priority
Date :NA

(33) Name
of priority :NA
country

(86)
International
Application :NA
No :NA

Filing
Date

(87)
International
Publication : NA
No

(61) Patent
of Addition
to
Application :NA
Number :NA

Filing
Date

(62)
Divisional to

Application :NA
Number :NA

Filing
Date

(71)**Name of Applicant :**
**1)Vel Tech Rangarajan
Dr. Sagunthala R&D
Institute of Science and
Technology**

Address of Applicant
:No.42, Avadi Vel Tech
Road, Avadi, Chennai -
600 062 Tamil Nadu,
India Tamil Nadu India

(72)**Name of Inventor :**
**1)RUSHIKESH
MILIND PURANIK
2)Dr.J.M.BABU**

(57) Abstract :

ADVANCED INTAKE SYSTEM FOR INTERNAL COMBUSTION ENGINE A strong, reliable and efficient intake manifold for a turbocharged internal combustion engine, which helps to increase volumetric efficiency, reduces the exhaust gas temperature and dilute it which helps to improve the efficiency of the turbocharged internal combustion engine. One extra runner is connected between intake and exhaust runners. Along with this at the center of this runner one butterfly valve is placed to regulate the flow of air which will be controlled by the engine ECU (Electronic Control Unit). The exhaust valve opens more, ie; 10°-12°. So during the valve overlap period the exhaust valve will remain open for extra 10° to 12° of the crank rotation and during this period only the one sided butterfly valve will get open to provide excess air inside the cylinder through the exhaust manifold which helps to improve the volumetric efficiency of the engine. Main illustrative figure is Fig. 3

No. of Pages : 16 No. of Claims : 3

(12) PATENT APPLICATION PUBLICATION

(21) Application
No.201941051957 A

(19) INDIA

(22) Date of filing of Application :14/12/2019

(43) Publication Date :
20/12/2019

(54) Title of the invention : AN AUTOMATIC SYSTEM AND METHOD FOR FISH POSITIONING

(51)
International
Classification
No
(31) Priority
Document :NA
No
(32) Priority
Date :NA
(33) Name
of priority :NA
country
(86)
International
Application :NA
No :NA
Filing
Date
(87)
International
Publication : NA
No
(61) Patent
of Addition
to :NA
Application :NA
Number
Filing
Date
(62)
Divisional
to :NA
Application :NA
Number
Filing
Date

(71)Name of Applicant :
**1)Vel Tech Rangarajan
Dr. Sagunthala R&D
Institute of Science and
Technology**
Address of Applicant
:No.42, Avadi Vel Tech
Road, Avadi, Chennai - 600
062 Tamil Nadu, India Tamil
Nadu India
(72)Name of Inventor :
**1)Dr. G.R.
KANGACHIDAMBARESA
N
2)K.PREMA
3)V.Suriyaa**

(57) Abstract :

AN AUTOMATIC SYSTEM AND METHOD FOR FISH POSITIONING An automatic fish positioning system and method for fish packaging industry that identify and change the position of the fish with the help of the technology of neural network. The image of the fish is captured through a web camera as videos and converted into frames. The initial position of the fish image is taken, and the position is identified using CNN (Convolutional Neural Network) algorithm. If the position of the fish is correct, then the robotic arm remains static without changing the object. If the position of the fish is incorrect then the control signal passes to the robotic arm through Raspberry pi (computing device), wherein the arm changes the position of the fish and place it back in the conveyor for further process. Main illustrative figure is Fig.1

No. of Pages : 23 No. of Claims : 4

(12) PATENT APPLICATION PUBLICATION

(21) Application
No.201941051958 A

(19) INDIA

(22) Date of filing of Application :14/12/2019

(43) Publication Date :
20/12/2019

(54) Title of the invention : A METHOD AND APPARATUS FOR INCREASING THE EFFICIENCY OF AN ENGINE.

(51)
International :F02M0035100000,H01M0010520000,B60K0013020000,F02M0025120000,H01M0002120000
classification
(31) Priority
Document :NA
No
(32) Priority :NA
Date
(33) Name
of priority :NA
country
(86)
International
Application :NA
No :NA
Filing
Date
(87)
International : NA
Publication
No
(61) Patent
of Addition
to
Application :NA
Number :NA
Filing
Date
(62)
Divisional to
Application :NA
Number :NA
Filing
Date

(71)Name of
Applicant :
1)Vel Tech
Rangarajan Dr.
Sagunthala R&D
Institute of Science
and Technology
Address of
Applicant :No.42,
Avadi Vel Tech Road,
Avadi, Chennai - 600
062 Tamil Nadu, India
Tamil Nadu India
(72)Name of Inventor
:
1)Kirubakaran V
2)Dr.David Sharad
Bhatt
3)Dr.R.Naren
Shankar

(57) Abstract :

A METHOD AND APPARATUS FOR INCREASING THE EFFICIENCY OF AN ENGINE A method and apparatus to improve the efficiency of an engine. Connecting the battery ventilation port to engine intake manifold will improve the ventilation capability of lead acid battery by providing the low pressure region in engine inlet during suction of incoming air for combustion. This low pressure region in intake manifold of car will drives the oxy-hydrogen gas from battery to engine for combustion. The oxy-hydrogen gas will be produced in battery only in charging process. Whenever the vehicle is running there is always the suction force experienced in engine intake, this suction force is responsible for receiving the oxy-hydrogen gas from battery into the engine(combustion zone). Due to which along with fuel the oxy-hydrogen gas also participate in combustion and gives excess energy by which overall efficiency of the engine is increased. Main illustrative figure is Fig.2

No. of Pages : 12 No. of Claims : 2

(12) PATENT APPLICATION PUBLICATION

(21) Application
No.201941051959 A

(19) INDIA

(22) Date of filing of Application :14/12/2019

(43) Publication Date :
20/12/2019

(54) Title of the invention : A METHOD FOR EVALUATING GROUNDWATER POLLUTION

(51)
International :G01N0033180000,G01N0033680000,C02F0103060000,G01S0007020000,G05B0013040000
classification
(31) Priority
Document :NA
No
(32) Priority :NA
Date
(33) Name
of priority :NA
country
(86)
International
Application :NA
No :NA
Filing
Date
(87)
International : NA
Publication
No
(61) Patent
of Addition
to
Application :NA
Number :NA
Filing
Date
(62)
Divisional to
Application :NA
Number :NA
Filing
Date

(71)**Name of Applicant**
:
**1)Vel Tech
Rangarajan Dr.
Sagunthala R&D
Institute of Science and
Technology**
Address of Applicant
:No.42, Avadi Vel Tech
Road, Avadi, Chennai -
600 062 Tamil Nadu,
India Tamil Nadu India
(72)**Name of Inventor :**
1)Dr S Samson

(57) Abstract :

A METHOD FOR EVALUATING GROUNDWATER POLLUTION The present invention relates to an evaluation method for underground water pollution using linear regression expression and it is used to find out the relation between TDS and other water quality parameters The characteristics of a data set can be explored using these techniques and a single numbered output can be arrived.

No. of Pages : 11 No. of Claims : 2

(12) PATENT APPLICATION PUBLICATION

(21) Application
No.201941051960 A

(19) INDIA

(22) Date of filing of Application :14/12/2019

(43) Publication Date :
20/12/2019

(54) Title of the invention : ENERGY HARVESTING BY PIEZOELECTRIC SENSOR ARRAY IN ROAD USING INTERNET OF THINGS

(51)
International :H02N0002180000,F03D0009250000,H01L0041113000,H02K0007180000,A43B000300000
classification
(31) Priority
Document :NA
No
(32) Priority :NA
Date
(33) Name
of priority :NA
country
(86)
International
Application :NA
No :NA
Filing
Date
(87)
International
Publication : NA
No
(61) Patent
of Addition
to
Application :NA
Number :NA
Filing
Date
(62)
Divisional to
Application :NA
Number :NA
Filing
Date

(71)Name of Applicant :
1)S.Sureshkumar
Address of Applicant
:Department of Computer
Science and Engineering,
Sri Krishna College of
Engineering and
Technology, Coimbatore
- 641008 Tamil Nadu
India
2)Dr.J.Janet
3)Dr.G.Radhakrishna
n
4)KR.Senthil
Murugan
5)D.Srivaishnavi
6)R.Kaviyaraj
7)A. Peter Soosai
Anandaraj
8)Vignesh T
(72)Name of Inventor :
1)S.Sureshkumar
2)Dr.J.Janet
3)Dr.G.Radhakrishna
n
4)KR.Senthil
Murugan
5)D.Srivaishnavi
6)R.Kaviyaraj
7)A. Peter Soosai
Anandaraj
8)Vignesh T

(57) Abstract :

Nowadays electricity is more important in our day-to-day life, Energy is being harvested by using external sources such as windmill, solar panel, kinetic energy etc. Here we are proposed to produce electricity in roads, pathway by using the piezoelectric sensors. Piezoelectric sensor works by converting mechanical energy into electrical energy. The electricity is produced by the pressure, vibration on the piezo electric sensor which is placed in roads or pathway. When the vehicle moves sensor generate electrical energy by using the pressure of the vehicle's weight. Then it is stored and used for Signals, Street lights etc.

No. of Pages : 7 No. of Claims : 4

(12) PATENT APPLICATION PUBLICATION

(21) Application
No.201941051971 A

(19) INDIA

(22) Date of filing of Application :15/12/2019

(43) Publication Date :
20/12/2019

(54) Title of the invention : VIDEO CAMERA POSITION SYSTEM FOR WIDE AREA MONITORING

(51)
International :H04N0005232000,H04N0007180000,F16M0011200000,G08B0013196000,G03B0017560000
classification

(31) Priority
Document :NA
No

(32) Priority
Date :NA

(33) Name
of priority :NA
country

(86)
International
Application :NA
No :NA

Filing
Date

(87)
International
Publication : NA
No

(61) Patent
of Addition
to
Application :NA
Number :NA

Filing
Date

(62)
Divisional to
Application :NA
Number :NA

Filing
Date

(71)Name of Applicant

:
**1)BHARATH
INSTITUTE OF
HIGHER
EDUCATION AND
RESEARCH**

Address of
Applicant :173,
Agharam Road,
Selaiyur, Chennai 600
073 Tamil Nadu India

(72)Name of Inventor :

**1)Dr. S. Prakash
2)Dr. V. Jayalakshmi
3)Dr. S.P. Vijaya
Ragavan
4)Anitha Sampath
Kumar**

(57) Abstract :

ABSTRACT Video camera position system for wide area monitoring This invention is a video camera positioning system for wide area monitoring. The system includes the interfacing of an RF transmitter, RF receiver module with PC for wireless camera positioning using microcontroller, a pair of encoder and decoder IC and its associated components in conjunction with Visual Basic programming language. When the input is transmitted the motor driving circuit drives the motor. The movement of the camera is designed to rotate 360 degrees panning either clockwise or anticlockwise direction and 180 degrees tilting up and down direction. The rotation or movement of the camera is not based on a set pattern. Instead, it is random and therefore it is not possible to predict the position of the camera in the next instant.

No. of Pages : 7 No. of Claims : 2

(12) PATENT APPLICATION PUBLICATION

(21) Application
No.201941051972 A

(19) INDIA

(22) Date of filing of Application :15/12/2019

(43) Publication Date :
20/12/2019

(54) Title of the invention : USING OF THERMO ELECTRIC EFFECT TO MAKE THE REFRIGERATOR

(51)
International :H01L0035320000,H01L0035280000,H01L0023380000,H01L0035300000,H01L0035000000
classification
(31) Priority
Document :NA
No
(32) Priority :NA
Date
(33) Name
of priority :NA
country
(86)
International
Application :NA
No :NA
Filing
Date
(87)
International
Publication : NA
No
(61) Patent
of Addition
to
Application :NA
Number :NA
Filing
Date
(62)
Divisional to
Application :NA
Number :NA
Filing
Date

(71)**Name of Applicant :**
**1)BHARATH
INSTITUTE OF
HIGHER
EDUCATION AND
RESEARCH**
Address of Applicant
:173, Agharam Road,
Selaiyur, Chennai 600
073 Tamil Nadu India
(72)**Name of Inventor :**
**1)Dr. K. Sangeetha
2)Dr. Arulselvi
3)Siddharth**

(57) Abstract :

ABSTRACT Using of thermo electric effect to make the refrigerator This invention proposes a new thermoelectric refrigerator, which runs on the principle of thermoelectric effect. The thermoelectric effect is the direct conversion of temperature differences to electric voltage and vice versa. A thermoelectric device creates a voltage when there is a different temperature on each side. This effect can be used to cool objects or to heat them or cook them, because the direction of heating and cooling is determined by the polarity of the applied voltage. It clearly tackles the two main problems that world is facing today, saving of energy and also disposal of harmful gas, very efficiently.

No. of Pages : 6 No. of Claims : 1

(12) PATENT APPLICATION PUBLICATION

(21) Application
No.201941051973 A

(19) INDIA

(22) Date of filing of Application :15/12/2019

(43) Publication Date :
20/12/2019

(54) Title of the invention : AUTO PROCESS FOR SOFT DRINK BOTTLE CLEANING

(51)
International :B07C0005340000,G11B0020180000,G01N0021900000,B08B0009200000,C11D0003040000
classification
(31) Priority
Document :NA
No
(32) Priority :NA
Date
(33) Name
of priority :NA
country
(86)
International
Application :NA
No :NA
Filing
Date
(87)
International
Publication : NA
No
(61) Patent
of Addition
to
Application :NA
Number :NA
Filing
Date
(62)
Divisional to
Application :NA
Number :NA
Filing
Date

(71)Name of Applicant
:
**1)BHARATH
INSTITUTE OF
HIGHER
EDUCATION AND
RESEARCH**
Address of Applicant
:173, Agharam Road,
Selaiyur, Chennai 600
073 Tamil Nadu India
(72)Name of Inventor :
**1)Dr. E.Kanniga
2)D. Sridhar Raja
3)B. KalaiSelvi
4)R. Abinethri**

(57) Abstract :

ABSTRACT Auto process for soft drink bottle cleaning This invention introduces a new system and method to clean the bottles in an automatic process. When these bottles exit from the washer, they are then transported through a conveyor to be inspected through two light scanners to determine bottles with dirt defect or debris. From this stage, the bottles go through an electric device that scans and rejects those containing caustic residue defects. The bottles are now considered clean, free from dirt defect, debris and caustic residue defect, and are passed on for filling. As any quantity of dirt defect or caustic residue defect in a bottle is highly significant in a soft drink company, the number of defective bottles was considered rather than amount of dirt defect or caustic residue defect in a bottle. The bottles are now considered clean, free from dirt defect, debris and caustic residue defect, and are passed on for filling.

No. of Pages : 6 No. of Claims : 1

(12) PATENT APPLICATION PUBLICATION

(21) Application
No.201941051983 A

(19) INDIA

(22) Date of filing of Application :15/12/2019

(43) Publication Date :
20/12/2019

(54) Title of the invention : MODERN METHOD FOR SWITCHING ELECTRONICS COMPONENTS

(51)
International :G07C0009000000,G06K0007100000,A61B0005145000,A61B0005000000,G06F0021310000
classification
(31) Priority
Document :NA
No
(32) Priority :NA
Date
(33) Name
of priority :NA
country
(86)
International
Application :NA
No :NA
Filing
Date
(87)
International
Publication : NA
No
(61) Patent
of Addition
to
Application :NA
Number :NA
Filing
Date
(62)
Divisional to
Application :NA
Number :NA
Filing
Date

(71)**Name of Applicant**
:
**1)BHARATH
INSTITUTE OF
HIGHER
EDUCATION AND
RESEARCH**
Address of Applicant
:173, Agharam Road,
Selaiyur, Chennai 600
073 Tamil Nadu India
(72)**Name of Inventor :**
1)R.S. Sidharth Raj
2)Dr. S. Arulselvi
3)Dr. M. Jasmin
4)R. Hema

(57) Abstract :

ABSTRACT Modern method for electronics components on and off This invention proposes a novel system for locking and unlocking computer system, laptop, home door, suitcase, comprising sensors, GPS and microcontroller. If we lose the key or forget our password we are unable to obtain access. This invention introduces a new technology to enter the password quickly and correctly to gain access. This smart device has GPS, micro controller, sensor and biometric sensor. The GPS is to give user the current location and nearest location, and exact time, that we can unlock our door instantly when we approach the door and also the relevant electronics devices are switched on automatically. Similarly, when the person exits the room, this is detected by sensor causing the automatic locking of the door and switching off of the devices. This system is based on Android platform has Free Open Source Software for monitoring and controlling the electronics devices.

No. of Pages : 7 No. of Claims : 2

(12) PATENT APPLICATION PUBLICATION

(21) Application
No.201941051984 A

(19) INDIA

(22) Date of filing of Application :15/12/2019

(43) Publication Date :
20/12/2019

(54) Title of the invention : AUTO ROBOT TO CLEANING THE WATER TANK

(51)
International: B62D0057024000, B25J0015060000, E04G0023000000, A47L0001020000, B65G00479100
classification
n
(31) Priority
Document :NA
No
(32) Priority :NA
Date
(33) Name
of priority :NA
country
(86)
International
Application :NA
No :NA
Filing
Date
(87)
International
Publication :NA
No
(61) Patent
of Addition
to
Application :NA
Number :NA
Filing
Date
(62)
Divisional
to
Application :NA
Number :NA
Filing
Date

(71) Name of Applicant :
**1) BHARATH
INSTITUTE OF
HIGHER EDUCATION
AND RESEARCH**
Address of Applicant
:173, Agharam Road,
Selaiyur, Chennai 600 073
Tamil Nadu India
(72) Name of Inventor :
**1) Dr. J. Hameed
Hussain
2) Dr. PremJeyakumar
3) Dr. P. Naveen Chandra
n
4) D. Mohan Kumar**

(57) Abstract :

ABSTRACT Auto robot to cleaning the water tank This invention is a robotic vehicle that can move in the vertical position of wall or overhanging walls of tall buildings on the side wall of ships, etc. A micro controller, IR sensor, pneumatic valve, suction cup are used in this system for cleaning purpose. A magnetic force or vacuum pressure can be used to produce the fixing force on the walls and wheels or crawlers are available as part of the moving mechanism on flat and wide vertical surfaces. The gripping is required to sustain the robot or to move it upwards on the wall. Here the suction cup is used to stick the cup in the vertical wall flexible gripping so that robot will not fall or lift. The IR sensor is used to detect the nearby object which can send the sensing signal to micro controller. The analog ranger gives the information of distance to an object in the ranges view and also the digital indication of an object at or closer than a predefined distance. Here pneumatic valve is used to compressed gases as well as the rate and direction of flow which also control the action of device.

No. of Pages : 7 No. of Claims : 2

(12) PATENT APPLICATION PUBLICATION

(21) Application
No.201941051985 A

(19) INDIA

(22) Date of filing of Application :15/12/2019

(43) Publication Date :
20/12/2019

(54) Title of the invention : AUTO DETECTION OF CRACKS ON THE METAL OR GLASS SURFACE

(51)
International :B29C0073020000,G07C0005000000,B67D0001120000,G01N0021910000,G08B0021240000
classification
(31) Priority
Document :NA
No
(32) Priority :NA
Date
(33) Name
of priority :NA
country
(86)
International
Application :NA
No :NA
Filing
Date
(87)
International
Publication : NA
No
(61) Patent
of Addition
to
Application :NA
Number :NA
Filing
Date
(62)
Divisional to
Application :NA
Number :NA
Filing
Date

(71)**Name of Applicant**
:
**1)BHARATH
INSTITUTE OF
HIGHER
EDUCATION AND
RESEARCH**
Address of
Applicant :173,
Agharam Road,
Selaiyur, Chennai 600
073 Tamil Nadu India
(72)**Name of Inventor :**
**1)Dr. A. Mani
2)P. Dayakar
3)Meikandaan T.P**

(57) Abstract :

ABSTRACT Auto detection of cracks on the metal or glass surface This invention introduces a new system for finding the cracks or breaks on the metal surface and glass surface. This system uses IR sensor, Arduino, GSM module, GPS, D.C motor, spur gears, metal track, battery, glass track to design a new innovative wireless auto robot. In wireless technology the air acts as medium to transfer the signal from transmitter to receiver. Here the IR sensor can sense the crack or break of the metal plate or glass plate, then it send the signal to micro controller. The GPS finds out the location of the cracks or break, which is also sent to the micro controller. The micro controller sends this signal to control room or quality checking room for necessary action.

No. of Pages : 6 No. of Claims : 1

(12) PATENT APPLICATION PUBLICATION

(21) Application
No.201941051986 A

(19) INDIA

(22) Date of filing of Application :15/12/2019

(43) Publication Date :
20/12/2019

(54) Title of the invention : TOLL BOOTH DATA COLLECTION BY USING ELECTRONIC TAG

(51)
International :G07B0015060000,G08G0001017000,G06K0019077000,G06Q0050300000,G09B0029100000

classification

(31) Priority

Document :NA

No

(32) Priority :NA

Date

(33) Name

of priority :NA

country

(86)

International

Application :NA

No :NA

Filing

Date

(87)

International

Publication : NA

No

(61) Patent

of Addition

to

Application :NA

Number :NA

Filing

Date

(62)

Divisional to

Application :NA

Number :NA

Filing

Date

(71)Name of Applicant

:

**1)BHARATH
INSTITUTE OF
HIGHER
EDUCATION AND
RESEARCH**

Address of
Applicant :173,
Agharam Road,
Selaiyur, Chennai 600
073 Tamil Nadu India

(72)Name of Inventor :

**1)Dr. E.Kanniga
2)D. Sridhar Raja
3)B. KalaiSelvi
4)R. Abinethri**

(57) Abstract :

ABSTRACT Toll booth data collection by using electronic tag This invention proposes a new method and system of collecting toll. Here the transaction of money and status of vehicle information is updated to automatically by a technology of IoT. This invention uses micro controller, LCD display, motor, relay, USRT, IR sensor, RFID reader to design auto toll gate collection system. Here the RFID tag contains all the details such as name, number, nationality, etc of the vehicle owner and also the vehicle details such as make, registration number etc. The RFID tag to swipe over the reader and the information is given to a micro controller. Since raspberry pi is enabled with IoT, vehicle data base can be created an it can be connected to server by using as app in any system. This also provides a flexible frontend for toll gate authorities to have a complete update of the vehicle, toll collected and soon. A provision for identification of the vehicle is possible by switching on a Theft Control switch, that informs all the toll-stations to track the vehicle if it is passes through it.

No. of Pages : 8 No. of Claims : 2

(12) PATENT APPLICATION PUBLICATION

(21) Application
No.201941051987 A

(19) INDIA

(22) Date of filing of Application :15/12/2019

(43) Publication Date :
20/12/2019

(54) Title of the invention : WEATHER WARNING TO USER THROUGH SMS

(51)
International :H04M0001725000,H04W0004140000,H04Q0009000000,G01C0021200000,G16H0040670000
classification

(31) Priority
Document :NA
No

(32) Priority
Date :NA

(33) Name
of priority :NA
country

(86)
International
Application :NA
No :NA

Filing
Date

(87)
International
Publication : NA
No

(61) Patent
of Addition
to
Application :NA
Number :NA

Filing
Date

(62)
Divisional to
Application :NA
Number :NA

Filing
Date

(71)Name of
Applicant :
**1)BHARATH
INSTITUTE OF
HIGHER
EDUCATION AND
RESEARCH**
Address of
Applicant :173,
Agharam Road,
Selaiyur, Chennai 600
073 Tamil Nadu India

(72)Name of Inventor
:
**1)Dr. M.
Senthilkumar
2)Dr. B. Karthik
3)K. Subbulakshmi
4)S. Saravana**

(57) Abstract :

ABSTRACT Weather warning to user through SMS This invention is a system to automatically find out the weather conditions by using a GSM module. This system has LCD display, micro controller, sensors (temperature sensor, humidity sensor, light sensor). The sensors sense the status of the parameters like temperature, light, humidity of the surrounding areas. These sensed signals are passed to micro controller and then this information is conveyed to a GSM modem which is interfaced to it. The GSM modem now encodes this data as SMS message and sends this message to the user. And also this message will be displayed on LCD (Liquid Crystal Display). The annexed figure is a block diagram displaying the light sensor, rain detection sensor, GPS module, GSM module which are interfaced with micro controller. The micro controller transfers the measuring parameter to the user smart phone through the air medium.

No. of Pages : 6 No. of Claims : 1

(12) PATENT APPLICATION PUBLICATION

(21) Application No.201941051992 A

(19) INDIA

(22) Date of filing of Application :16/12/2019

(43) Publication Date : 20/12/2019

(54) Title of the invention : A DESIGN AND METHOD FOR AUTOMATIC PET WATERING AND FOOD FEEDING SYSTEM USING IOT

(51) International classification	:A01K5/00	(71)Name of Applicant :
(31) Priority Document No	:NA	1)DR.S.BALAKRISHNAN
(32) Priority Date	:NA	Address of Applicant :PROFESSOR AND HEAD,
(33) Name of priority country	:NA	DEPARTMENT OF COMPUTER SCIENCE AND BUSINESS
(86) International Application No	:NA	SYSTEM, SRI KRISHNA COLLEGE OF ENGINEERING AND
Filing Date	:NA	TECHNOLOGY, KUNIAMTHUR, COIMBATORE
(87) International Publication No	: NA	TAMILNADU INDIA-641008 Tamil Nadu India
(61) Patent of Addition to Application Number	:NA	2)DR.L.RAMANATHAN
Filing Date	:NA	3)DR ANANDA KUMAR SUBRAMANIAN
(62) Divisional to Application Number	:NA	4)DR MAHESH G
Filing Date	:NA	5)DR.PARTHASARATHY G
		6)DR.L.LAKSHMANAN
		(72)Name of Inventor :
		1)DR.S.BALAKRISHNAN
		2)DR.L.RAMANATHAN
		3)DR ANANDA KUMAR SUBRAMANIAN
		4)DR MAHESH G
		5)DR.PARTHASARATHY G
		6)DR.L.LAKSHMANAN

(57) Abstract :

AH these modern technologies just make people try to do everything at once. Nowadays, people tend to be busier; and because of this, people tend to forget also some of their responsibilities which are the main cause of trouble. One of these responsibilities is having a pet at home.. Most people want to have his/her own pet for its attractive appearance, loyalty and playful personality. Having a pet is an obligation which does not go into waste because having a pet serves entertainment and company at home. In this work, we proposed a new pet watering and food feeding system that can feed pets while owners are absent at their homes. Through the use of GSM module, owners can send message to the system for the bowl to be refilled. Also, GSM module sends notification to the owner when there is critical level on storages and the bowls. Load cell sensor (Hx711 Weight Weighing A/D Module) was used for monitoring the weight of the food bowl and water bowl to monitor if it is on a critical level. This idea is an excellent to protect the pets from starving whenever no one is at home and all are busy with their scheduled routine works and job at office or in business. The cost of a care taking of a pet has been reduced down due to the launching of such machine in the market. Such idea is being globally getting popular due to automatic system and mobile app involvement.

No. of Pages : 6 No. of Claims : 4

(12) PATENT APPLICATION PUBLICATION

(21) Application
No.201941052041 A

(19) INDIA

(22) Date of filing of Application :16/12/2019

(43) Publication Date :
20/12/2019

(54) Title of the invention : CRICKET GAME INTELLIGENT BOT UMPIRE FOR AUTOMATED UMPIRING AND SCORING DECISIONS DURING CRICKET MATCH

(51)
International :A63B0071060000,A63F0009000000,G06K0009000000,A63D0015200000,G06F0011340000
classification
(31) Priority
Document :NA
No
(32) Priority :NA
Date
(33) Name
of priority :NA
country
(86)
International
Application :NA
No :NA
Filing
Date
(87)
International : NA
Publication
No
(61) Patent
of Addition
to
Application :NA
Number :NA
Filing
Date
(62)
Divisional to
Application :NA
Number :NA
Filing
Date

(71)**Name of Applicant**
:
**1)CRICKETRONICS
PRIVATE LIMITED**
Address of Applicant
:68, 2ND FLOOR,
C.P.RAMASAMY
ROAD, ALWARPET,
CHENNAI 600 018.
Tamil Nadu India
(72)**Name of Inventor** :
**1)NAGARAJAN
SOODAMMANI**

(57) Abstract :

ABSTRACT The present disclosure is directed to a non-intrusive, integrated system comprising an umpire bot for automatically monitoring, umpiring, scoring, analytics, learning and coaching for players while eliminating need for human umpires and scorers. The automated umpire bot with intelligent telescopic function monitors, cognitively recognizes and captures movements from all equipment™s, analyses them, moves up and down and even avoid ball collision travelling towards it. The non-intrusive real time system captures all the game moments right from players initiation, toss of coin, commencement of game, monitoring field positions, keeping scores, umpiring decisions, overs, valid / in-valid deliveries, validating balls per over, wickets, catches, boundaries, sixes and displaying scores and statistics all throughout the game.

No. of Pages : 67 No. of Claims : 17

(12) PATENT APPLICATION PUBLICATION

(21) Application
No.201941052050 A

(19) INDIA

(22) Date of filing of Application :16/12/2019

(43) Publication Date :
20/12/2019

(54) Title of the invention : ISOLATION, CHARACTERIZATION AND MASS PRODUCTION OF CHLOROANTHOMYCIN WITH ANTI-CANCER AND ANTIBIOTIC ACTIVITY

(51)
International :C21D0006000000,G01N0021640000,C12R0001070000,C12P0017160000,C07G0011000000
classification

(31) Priority
Document :NA
No

(32) Priority :NA
Date

(33) Name
of priority :NA
country

(86)
International
Application :NA
No :NA

Filing
Date

(87)
International : NA
Publication
No

(61) Patent
of Addition
to
Application :NA
Number :NA

Filing
Date

(62)
Divisional to
Application :NA
Number :NA

Filing
Date

(71)Name of Applicant
:
**1)Dr A. AMRUTHA
VALLI**

Address of Applicant
:Department of
Microbiology, Acharya
Nagarjuna University,
Guntur-522510, Andhra
Pradesh. India Andhra
Pradesh India

(72)Name of Inventor :
**1)Dr A. AMRUTHA
VALLI**
2)Dr M. SAI RAM

(57) Abstract :

ISOLATION, CHARACTERIZATION AND MASS PRODUCTION OF CHLOROANTHOMYCIN WITH ANTI-CANCER AND ANTIBIOTIC ACTIVITY Exemplary embodiments of the present disclosure are directed towards a method for isolation, characterization and mass production of chloroxanthomycin with anti-cancer and antibiotic activity. Bacillus sp from chilli agricultural fields of Guntur district that fluoresce orange colour, was identified as Bacillus endophyticus by 16s rRNA sequencing and the isolate is deposited in NCBI as B.endophyticus AVP9 with Accession Number (KF527823). Chloroxanthomycin, an orange fluorescence, non-diffusible chlorinated pigment and a simple and cost effective methodology to isolate this intra cellular pigment in four phase manner is elucidated herein. The four phases include mass cultivation and extraction of IOFP, phase separation, thin layer chromatography and column chromatography. FIG.4

No. of Pages : 35 No. of Claims : 9

(12) PATENT APPLICATION PUBLICATION

(21) Application No.201941052172 A

(19) INDIA

(22) Date of filing of Application :16/12/2019

(43) Publication Date : 20/12/2019

(54) Title of the invention : ORGANIC VAYU PURIFIER SYSTEM (OVPS)

(51) International classification :C12Q1/68
(31) Priority Document No :NA
(32) Priority Date :NA
(33) Name of priority country :NA
(86) International Application No :NA
Filing Date :NA
(87) International Publication No : NA
(61) Patent of Addition to Application Number :NA
Filing Date :NA
(62) Divisional to Application Number :NA
Filing Date :NA

(71)Name of Applicant :

1)DR.C.VENKATESH

Address of Applicant :Principal, Sengunthar Engineering
College, Tiruchengode Tamil Nadu India

2)Mr. P.JAGADEESWARAN

3)Dr.P.PONMURUGAN

(72)Name of Inventor :

1)DR.C.VENKATESH

2)Mr. P.JAGADEESWARAN

3)Dr.P.PONMURUGAN

4)Mr.P.THANGARASU

5)T.KARTHIK

6)J.KAVIN KUMAR

7)V.NIKHIL

(57) Abstract :

This invention is a simple, low cost, natural air purification mechanism powered by solar cells. An air purifier or air cleaner is a device which removes contaminants from the air in a room to improve indoor air quality. This Organic air (Vayu) purifier system is a five-layer mechanism used to filter, purify the air, kill germs and increase the fragrance of the room. The system piggybacks off the natural processes of air purifying plant composites which naturally eliminate toxins in the air. The process comes down to its filter and its design, which increases airflow through the plant composite. The entire system is completely eco-friendly as the purifier uses plant composites for purification and is powered by solar cells.

No. of Pages : 6 No. of Claims : 10

(12) PATENT APPLICATION PUBLICATION

(21) Application
No.201941052200 A

(19) INDIA

(22) Date of filing of Application :17/12/2019

(43) Publication Date :
20/12/2019

(54) Title of the invention : SIMPLE WAY TO OPEN THE IRON LOCK

(51)
International :G07C0009000000,G06F0003048800,G06F0021320000,E05B0049000000,F41A0017060000
classification
(31) Priority
Document :NA
No
(32) Priority :NA
Date
(33) Name
of priority :NA
country
(86)
International
Application :NA
No :NA
Filing
Date
(87)
International
Publication : NA
No
(61) Patent
of Addition
to
Application :NA
Number :NA
Filing
Date
(62)
Divisional to
Application :NA
Number :NA
Filing
Date

(71)Name of Applicant :
**1)BHARATH
INSTITUTE OF
HIGHER EDUCATION
AND RESEARCH**
Address of Applicant
:173, Agharam Road,
Selaiyur, Chennai 600
073 Tamil Nadu India
(72)Name of Inventor :
**1)M. SowmiyaManoj
2)G. Angelo Virgin
3)G. Jeyalakshmi**

(57) Abstract :

ABSTRACT Simple way to open the iron lock This invention proposes a novel biometric based locking and unlocking system that works with the traditional iron lock that is used. This invention introduces a technology for simple way to open the iron door lock. Here we use biometric sensor and micro controller which is configured to lock or unlock the iron lock. When an authorized user touches this iron lock, it automatically opens and there is no need for key to put in this iron lock. Here the biometric sensor senses the user's finger print and it sends to the micro controller which is configured to unlock the iron locker. If unauthorized person touches or tries to break this lock then a message is sent to the user. The annexed figure mentions the micro controller, LCD display, buzzer those are interfaced together, which is used to embed in other machinery.

No. of Pages : 7 No. of Claims : 2

(12) PATENT APPLICATION PUBLICATION

(21) Application No.201941052202 A

(19) INDIA

(22) Date of filing of Application :17/12/2019

(43) Publication Date : 20/12/2019

(54) Title of the invention : NANO BIO-HYBRID METFORMIN COMPOSITION FOR TREATING NON-INSULIN DEPENDENT DIABETES MELLITUS

(51) International classification :C07K14/50
(31) Priority Document No :NA
(32) Priority Date :NA
(33) Name of priority country :NA
(86) International Application No :NA
Filing Date :NA
(87) International Publication No : NA
(61) Patent of Addition to Application Number :NA
Filing Date :NA
(62) Divisional to Application Number :NA
Filing Date :NA

(71)Name of Applicant :

1)Dr.G.V.Radha

Address of Applicant :D/o G.V.Rama Rao GITAM Institute of Pharmacy GITAM Deemed to be University Rushikonda, Visakhapatnam-530045 Andhra Pradesh, India Andhra Pradesh India

(72)Name of Inventor :

1)Dr.G.V.Radha

2)Santhosh Kumar C

(57) Abstract :

ABSTRACT: Title: Nano Bio-hybrid Metformin Composition for Treating Non-Insulin Dependent Diabetes Mellitus The present disclosure proposes a nano bio-hybrid composition of metformin with a synergistic effect for the treatment of NIDDM (type 2 diabetes). The nano bio-hybrid metformin composition for NIDDM comprises 13 to 15 percentage of tri-polyphosphate, 18 to 20 percentage of chitosan, 47 to 79 percentage of metformin, and 18 to 20 percentage of citrus pectin. The metformin is pre-incubated with HCL chitosan to facilitate electrostatic interaction between the amphoteric polymer and cationic metformin. The nano bio-hybrid composition of metformin aids to reduce various NIDDM dependent effects including dyslipidemia, renal damage, anti-oxidant enzyme level, carbohydrate metabolizing enzyme level, inflammatory cytokines, insulin levels and bioavailability. The proposed composition enhances-cell regeneration and prevents the further damage of organs associated with NIDDM. The nano bio-hybrid composition of metformin provides improved stability, therapeutic efficiency, and extended release of the drug and is also used as a prodrug. The proposed composition of metformin enhances glucose uptake in RBCs and skeletal muscles and provides improved haemocompatibility, and protein binding.

No. of Pages : 42 No. of Claims : 8

(12) PATENT APPLICATION PUBLICATION

(21) Application No.201941052203 A

(19) INDIA

(22) Date of filing of Application :17/12/2019

(43) Publication Date : 20/12/2019

(54) Title of the invention : A METHOD OF COATING SILICON CARBIDE ON GRAPHENE NANOPATELETS

(51) International classification :B82Y30/00
(31) Priority Document No :NA
(32) Priority Date :NA
(33) Name of priority country :NA
(86) International Application No :NA
Filing Date :NA
(87) International Publication No : NA
(61) Patent of Addition to Application Number :NA
Filing Date :NA
(62) Divisional to Application Number :NA
Filing Date :NA

(71)Name of Applicant :
1)Kalyana Manohar Veeramallu
Address of Applicant :S/o Sri Satya Narasimha Rao.V
Department of Mechanical Engineering, University of College of
Engineering Kakinada (A), JNTUK, Kakinada-533003, East
Godavari, Andhra Pradesh, India Andhra Pradesh India
2)Dr.Alluru Gopala Krishna
(72)Name of Inventor :
1)Kalyana Manohar Veeramallu
2)Dr.Alluru Gopala Krishna

(57) Abstract :

ABSTRACT: Title: A Method of Coating Silicon Carbide on Graphene Nanoplatelets The present disclosure discloses a method of coating silicon carbide on graphene nanoplatelets. The method of coating silicon carbide on graphene nanoplatelets includes placing the reactants in a crucible and sintering in a vacuum sintering furnace at a certain temperature for a specified soaking time. The proposed method is of low cost and is simple that improves oxidation resistance of graphene nanoplatelets to thereby enable its use in high temperature applications. The proposed nanoplatelets can be used as a reinforcement for metal or ceramic matrix composites to enhance the mechanical properties such as strength, hardness, toughness, wear resistance, and thermal conductivity. The silicon carbide coated graphene nanoplatelets find applications for cutting tools, heat sinks, electronic packaging, etc.

No. of Pages : 27 No. of Claims : 9

(12) PATENT APPLICATION PUBLICATION

(21) Application
No.201941052206 A

(19) INDIA

(22) Date of filing of Application :16/12/2019

(43) Publication Date :
20/12/2019

(54) Title of the invention : COTTON FABRIC TREATED WITH LIQUID STATE PHOTO CATALYST TO FILTER THE INCOMING AIR

(51)
International :B01J0035000000,B01J0021060000,A61L0009200000,C02F0001320000,B01J0019120000
classification
(31) Priority
Document :NA
No
(32) Priority :NA
Date
(33) Name
of priority :NA
country
(86)
International
Application :NA
No :NA
Filing
Date
(87)
International : NA
Publication
No
(61) Patent
of Addition
to
Application :NA
Number :NA
Filing
Date
(62)
Divisional to
Application :NA
Number :NA
Filing
Date

(71)**Name of Applicant :**
**1)VISWESWARAN
BALASUBRAMANIAN**
Address of Applicant
:No: 3, Rajaji Street, Karur
- 639001, Tamilnadu, India
Tamil Nadu India
(72)**Name of Inventor :**
**1)VISWESWARAN
BALASUBRAMANIAN**

(57) Abstract :

A Cotton Fabric Treated with Liquid State Photo catalyst to filter the incoming air is disclosed. The cotton fabric is characterized in that it comprises a thin layer of photocatalyst titanium dioxide nanoparticles. On exposure to sunlight or ultraviolet light, the fabric absorbs pollutants in the air, in addition to microorganisms.

No. of Pages : 9 No. of Claims : 3

(12) PATENT APPLICATION PUBLICATION

(21) Application No.201941052245 A

(19) INDIA

(22) Date of filing of Application :17/12/2019

(43) Publication Date : 20/12/2019

(54) Title of the invention : PORTABLE AND REMOTE CONTROLLED VEHICLE TOWING UNIT

(51) International classification	:B60P3/11	(71)Name of Applicant :
(31) Priority Document No	:NA	1)BHARATH INSTITUTE OF HIGHER EDUCATION AND RESEARCH
(32) Priority Date	:NA	Address of Applicant :173, Agharam Road, Selaiyur, Chennai
(33) Name of priority country	:NA	600 073 Tamil Nadu India
(86) International Application No	:NA	(72)Name of Inventor :
Filing Date	:NA	1)Dr. A. Kumaravel
(87) International Publication No	: NA	2)M. Ramamoorthy
(61) Patent of Addition to Application Number	:NA	3)P. Kavitha
Filing Date	:NA	4)Thirunavukkarasu
(62) Divisional to Application Number	:NA	
Filing Date	:NA	

(57) Abstract :

ABSTRACT PORTABLE AND REMOTE CONTROLLED VEHICLE TOWING UNIT This invention is related to a portable and remote controlled towing unit. This towing unit is an ancillary equipment kept inside the vehicle. This is like a wheel jack and can be fixed on any wheel based on the requirement. This is a remote controlled hydraulic system comprising turning and braking systems for towing the vehicle. First we should fix this unit in any vehicle and switch on the hydraulic system to lift the vehicle. Now the vehicle is ready to be towed. During towing, it allows the control of the vehicle and the towing unit as well remotely

No. of Pages : 6 No. of Claims : 1

(12) PATENT APPLICATION PUBLICATION

(21) Application No.201941052262 A

(19) INDIA

(22) Date of filing of Application :17/12/2019

(43) Publication Date : 20/12/2019

(54) Title of the invention : TRANSPARENT SMART WINDOW DISPLAY FOR CAR AND BUILDING

(51) International classification	:G02F1/16	(71)Name of Applicant :
(31) Priority Document No	:NA	1)BHARATH INSTITUTE OF HIGHER EDUCATION
(32) Priority Date	:NA	AND RESEARCH
(33) Name of priority country	:NA	Address of Applicant :173, Agharam Road, Selaiyur, Chennai
(86) International Application No	:NA	600 073 Tamil Nadu India
Filing Date	:NA	(72)Name of Inventor :
(87) International Publication No	: NA	1)Dr. P.NaveenChandran
(61) Patent of Addition to Application Number	:NA	2)Dr. J. Hameed Hussain
Filing Date	:NA	3)Dr.K.Chidambaram
(62) Divisional to Application Number	:NA	
Filing Date	:NA	

(57) Abstract :

ABSTRACT Transparent smart window display for car and building This invention introduces a new innovative technique that can be used in car windows or house windows or building windows. Here we use indium-free material, sensor and micro controller. For many electronic devices, the key component is the thin film transistor. These systems are made using indium-free materials and alternating layers of transparent oxides and could potentially be used to make transparent displays. Here the sensors sense the signal from the user then it sends the signal to the microcontroller. The micro controller is used to operate this transparent window display, which can be changed from being very transparent to being less transparent, thereby controlling the amount of light and heat that passes through the glass. The electro chrominance effect is used here.

No. of Pages : 7 No. of Claims : 2

(12) PATENT APPLICATION PUBLICATION

(21) Application
No.201941052264 A

(19) INDIA

(22) Date of filing of Application :17/12/2019

(43) Publication Date :
20/12/2019

(54) Title of the invention : MODERN COAT FOR SOLDIERS

(51)
International :G08B0021040000,G06Q0020320000,H04W0004020000,H04N0005232000,H04N0009310000
classification
(31) Priority
Document :NA
No
(32) Priority :NA
Date
(33) Name
of priority :NA
country
(86)
International
Application :NA
No :NA
Filing
Date
(87)
International : NA
Publication
No
(61) Patent
of Addition
to
Application :NA
Number :NA
Filing
Date
(62)
Divisional to
Application :NA
Number :NA
Filing
Date

(71)**Name of Applicant :**
1)BHARATH HIGHER EDUCATION AND RESEARCH
Address of Applicant :173, Agharam Road, Selaiyur, Chennai 600 073 Tamil Nadu India
(72)**Name of Inventor :**
1)Dr. M. Senthilkumar
2)Dr. B. Karthik
3)K. Subbulakshmi
4)S. Saravana

(57) Abstract :

ABSTRACT Modern coat for soldiers This invention is a coat that can be worn by the person and it enables maintaining the desired body temperature inside this coat, naturally by insulating the wearer from the outside temperature. This coat has GPS, GSM module, sensor, micro controller, camera, and projector. Those are linked with user smart phone and when the user uses this coat the components start operating automatically. The GPS is used to track the location of the user, and the sensor can sense the temperature, pressure, and obstacle. These signals are sent to the micro controller, which sends it to the GSM module to the user smart phone wirelessly. This coat is also attached with camera and when the user wants to capture images or videos they just press the switch of the camera and the captured images may be sent to a remote control room.

No. of Pages : 8 No. of Claims : 3

(12) PATENT APPLICATION PUBLICATION

(21) Application No.201941052333
A

(19) INDIA

(22) Date of filing of Application :17/12/2019

(43) Publication Date : 20/12/2019

(54) Title of the invention : CONSUMER END LOAD SCHEDULING AND MONITORING USING IOT

(51)

International :H04L0029080000,H02J0003140000,H04M0015000000,G06Q0030020000,G01D0004100000
classification

(31) Priority

Document :NA
No

(32) Priority :NA
Date

(33) Name
of priority :NA
country

(86)

International
Application :NA
No :NA

Filing

Date

(87)

International : NA
Publication
No

(61) Patent
of Addition
to

Application :NA
Number :NA

Filing

Date

(62)

Divisional to
Application :NA
Number :NA

Filing

Date

(71)Name of Applicant :

1)Dr.M.S.SARAVANAN

Address of Applicant :Associate
Professor, Department of Electrical &
Electronics Engineering, Mahendra
College of Engineering, Minnampalli,
Salem. Tamil Nadu India

**2)DR.K.S.CHANDRAGUPTA
MAURYAN**

3)Dr.P.PONMURUGAN

(72)Name of Inventor :

1)Dr.M.S.SARAVANAN

**2)DR.K.S.CHANDRAGUPTA
MAURYAN**

3)Dr.P.PONMURUGAN

(57) Abstract :

This system is a design and implementation of a metering system which interface with utility-side and load-side management. The system can be used in two variants - postpaid and prepaid with cost efficient dynamic tariff plans based on demand and consumption time. The system is made up of a microcontroller unit with an embedded communication module. The communication among the supplier/authority, the system, and consumer is established by their respective identification numbers using Internet of Things (IoT). The consumer and authority can communicate with the system and among themselves through android mobile application. The consumer can schedule his electrical loads; can report the authority in case of any power supply interruption and also authority can inform his end user about the scheduled power interruption in case of any maintenance work. This system can be configured and reconfigured remotely by the android mobile application without changing hardware. Energy consumption status and fault at the consumer line can be monitored with the proposed metering system.

No. of Pages : 11 No. of Claims : 8

(54) Title of the invention : AUTOMATED SECURITY THREAT ANALYSIS AND EXECUTING OPTIMAL RESPONSE FOR WIRELESS SENSOR NETWORKS

(51) International :H04L0029060000,H04L0029080000,G06F0021550000,G06F0021560000,G06N0003080000 classification

(31) Priority Document :NA
No

(32) Priority Date :NA

(33) Name of priority :NA
country

(86) International Application :PCT//
No :01/01/1900
Filing Date

(87) International Publication : NA
No

(61) Patent of Addition to Application :NA
Number :NA
Filing Date

(62) Divisional to Application :NA
Number :NA
Filing Date

(71)Name of Applicant :
1)DR.P.DEEPALAKSHMI
 Address of Applicant :Professor,
 Department of CSE, Kalasalingam
 Academy of Research and Education,
 Anand Nagar, Krishnankoil
 Srivilliputhur, Tamil Nadu India626126
 Tamil Nadu India
2)DR.V.PRAVEENA
3)DR.P.CHINNASAMY
4)DR.S.GEETHA
5)DANTHULURI SUDHA
6)p nagaraj
7)K.MUTHAMIL SUDAR

(72)Name of Inventor :
1)DR.P.DEEPALAKSHMI
2)DR.V.PRAVEENA
3)DR.P.CHINNASAMY
4)DR.S.GEETHA
5)DANTHULURI SUDHA
6)p nagaraj
7)K.MUTHAMIL SUDAR

(57) Abstract :

Abstract: Wireless sensor networks (WSNs) have wide applications these days in all industries. However, sensed data and sensor nodes are susceptible to various security threats owing to their distributed nature and their deployment in remote areas. This can have an undesirable effect on their performance, especially if the network is used for mission-critical applications. The existing threat analysis methods, attack detection and attack responses are not integrated together and optimal response towards the attack are reactive in nature. The integrated threat matrix analysis, security rules, guidelines, and prevention measures are automated and updated using GAN (Generative Adversarial Network) machine learning algorithms by analyzing traffic patterns as whether real or fake and node states. Fake and Real traffic differentiation involves multiple layers of traffic pattern analysis. The prevention measures also updated by learning history of attacks and malicious patterns. The optimal response to attacks includes cut off the sensor node, blocking the traffic, and reporting malicious behaviour. The technique used to respond the attack through a separate secure channel between sensor and master node or server to send commands.

No. of Pages : 3 No. of Claims : 6

(54) Title of the invention : Continuous Energy Supply to House Hold Appliances through Uninterrupted Power Meter

(51) International classification :H02J0009060000,H02J0003140000,H04B0003540000,H02J0009000000,A47J0027210000

(31) Priority Document No :NA

(32) Priority Date :NA

(33) Name of priority country :NA

(86) International Application No :PCT//01/01/1900

Filing Date

(87) International Publication No :NA

(61) Patent of Addition to Application Number :NA

Filing Date

(62) Divisional to Application Number :NA

Filing Date

(71)Name of Applicant :

1)Dr. R. Nafeena/ECE
Address of Applicant :KINGS ENGINEERING COLLEGE, Chennai Bangalore Highway, Opposite to Hyundai Motors, Sriperumbudur Taluk, Irungattukottai-602117, Tamilnadu Tamil Nadu India

2)S.Vatchala
3)Dr.R.Gopi
4)Richard Jimreeves J.S,Assistant Professor/ IT
5)Dr. M. Senthil Kumar
6)A. A Abdul Munaf/ Mech
7)Dr S. Padmapriya
8)Dr.S.Arun ,Prof ECE
9)Dr.A. Nageswaran
10)Dr.N.PARTHEEBAN
11)K. Sudharson

(72)Name of Inventor :

1)Dr. R. Nafeena/ECE
2)S.Vatchala
3)Dr.R.Gopi
4)Richard Jimreeves J.S,Assistant Professor/ IT
5)Dr. M. Senthil Kumar
6)A. A Abdul Munaf/ Mech
7)Dr S. Padmapriya
8)Dr.S.Arun ,Prof ECE
9)Dr.A. Nageswaran
10)Dr.N.PARTHEEBAN
11)K. Sudharson

(57) Abstract :

With the foregoing and other objects in view there is provided, in accordance with the invention, an uninterruptible power distribution system for household and buildings, said system comprising a first electrical power supply connection to be provided from the electrical board through a mains power supply; a second electrical power supply connection to be provided to the plurality of electrical appliances from the mains power supply; a third electrical power supply connection with a constant power level to be provided to a pre-determined number of electrical appliances from the said mains power supply; a first pool of electrical appliances in the said household and buildings; a second pool of electrical appliances categorised for emergency services derived from the said first pool of appliances; at least one switching device for selectively switching the connection of the electrical load incorporated in the said first, second and third electrical power supply connection and at least one micro controller and/or processor for detecting the mode of electrical supply from the mains and communicating with the said at least one switching device. Fig. 4

No. of Pages : 24 No. of Claims : 10

(12) PATENT APPLICATION PUBLICATION

(21) Application
No.201941052711 A

(19) INDIA

(22) Date of filing of Application :18/12/2019

(43) Publication Date :
20/12/2019

(54) Title of the invention : Smart Flash Light

(51)
International :H01L0035300000,H01L0035320000,F21V0033000000,H01L0035000000,F21V0029700000
classification

(31) Priority
Document :NA
No

(32) Priority
Date :NA

(33) Name
of priority :NA
country

(86)
International
Application :PCT//
No :01/01/1900

Filing
Date
(87)
International
Publication : NA
No

(61) Patent
of Addition
to
Application :NA
Number :NA

Filing
Date
(62)

Divisional to
Application :NA
Number :NA
Filing
Date

(71)Name of Applicant :
**1)BHARATH
INSTITUTE OF
HIGHER
EDUCATION AND
RESEARCH**

Address of Applicant
:173, Agharam Road,
Selaiyur, Chennai 600
073 Tamil Nadu India

(72)Name of Inventor :
**1)C. Anuradha
2)S. Pothumani
3)D. Vimala
4)I. Mary Linda**

(57) Abstract :

ABSTRACT Smart Flash Light This invention introduces a new technology for powering a light bulb. Here we use thermo electric generator to operate the flash light. Thermoelectric generator is a solid state semi-conductor device that converts a temperature difference and heat flow into generate voltage, which is useful to power a load. When the users puts his hand on the thermoelectric generator it converts the thermal energy in to electric energy to the power the bulb / LED switch on. This project useful to people and it does not use any battery so we can save energy. It clearly tackles the two main problems that world is facing today, saving of energy and also generation of electricity very efficiently. The above fig: mention when the user put the thermal energy ten it will convert into electrical energy.

No. of Pages : 6 No. of Claims : 2

(12) PATENT APPLICATION PUBLICATION

(21) Application
No.201941052741 A

(19) INDIA

(22) Date of filing of Application :18/12/2019

(43) Publication Date :
20/12/2019

(54) Title of the invention : BLOCKCHAIN METHOD OF IOT BASED SOLUTIONS FOR FINANCES TRANSACTION
MANAGEMENT OF CRYPTO CURRENCY

(51)
International :H04L0009320000,G06Q0020060000,G06Q0040020000,G06Q0040000000,G06Q0020400000
classification
(31) Priority
Document :NA
No
(32) Priority :NA
Date
(33) Name
of priority :NA
country
(86)
International
Application :PCT//
No :01/01/1900
Filing
Date
(87)
International : NA
Publication
No
(61) Patent
of Addition
to
Application :NA
Number :NA
Filing
Date
(62)
Divisional to
Application :NA
Number :NA
Filing
Date

(71)Name of Applicant
:
**1)Dr. V. B.
Narasimha**
Address of
Applicant :Assistant
Professor, Department
of Computer Science
and Engineering,
University College of
Engineering, Osmania
university, Hyderabad,
Telangana State, India
Telangana India
2)Dr. S. Nagaprasad
(72)Name of Inventor :
**1)Dr. V. B.
Narasimha**
2)Dr. S. Nagaprasad

(57) Abstract :

The present invention relates to block chain method of Internet of things (IoT) based solutions for finances transaction management of crypto currency. The objective of the present invention is to overcome the inadequacies of the prior arts in finances transaction management of crypto currency.

No. of Pages : 20 No. of Claims : 5

(12) PATENT APPLICATION PUBLICATION

(21) Application
No.201944045482 A

(19) INDIA

(22) Date of filing of Application :08/11/2019

(43) Publication Date :
20/12/2019

(54) Title of the invention : RAP7BALL GAME

(51)
International :A63B0059550000,A63F0003000000,A63B0067000000,A63F0001040000,A63F0013812000
classification
(31) Priority
Document :US 16/558,661
No
(32) Priority
Date :03/09/2019
(33) Name
of priority :U.S.A.
country
(86)
International
Application :NA
No :NA
Filing
Date
(87)
International
Publication : NA
No
(61) Patent
of Addition
to
Application :NA
Number :NA
Filing
Date
(62)
Divisional to
Application :NA
Number :NA
Filing
Date

(71)**Name of Applicant :**
1)RAJAN PAUL
Address of Applicant
:1682 CHASE DRIVE,
ROCHESTER,
MICHIGAN 48307, USA
U.S.A.
(72)**Name of Inventor :**
1)RAJAN PAUL

(57) Abstract :

A RaP7Ball game that is a combination of a cricket and baseball game is disclosed. The RaP7Ball game comprises the steps of using a field having an inverted equilateral triangle shaped inner field. The RaP7Ball game also includes the steps of choosing a first and second team with each team having fourteen players and using a bat and ball similar to that of a cricket bat and ball. The RaP7Ball game also includes the steps of playing three innings in the game and playing seven overs in each half inning. The method also comprises the steps of bowling seven balls in each over and counting runs scored by each team, wherein the team that scores the most runs at the end of the three innings may be declared the winner of the RaP7Ball game.

No. of Pages : 29 No. of Claims : 20

(12) PATENT APPLICATION PUBLICATION

(21) Application
No.201931044851 A

(19) INDIA

(22) Date of filing of Application :05/11/2019

(43) Publication Date :
20/12/2019

(54) Title of the invention : A SYSTEM TO HELP ACCESS SCHEMES OF GOVERNMENT TO PEOPLE HAVING A SINGLE INTERFACE

(51)
International :G06Q0010100000,G06F0016958000,H04N0007180000,G06T0019000000,A61M0005172000
classification
(31) Priority
Document :NA
No
(32) Priority :NA
Date
(33) Name
of priority :NA
country
(86)
International
Application :NA
No :NA
Filing
Date
(87)
International :NA
Publication
No
(61) Patent
of Addition
to
Application :NA
Number :NA
Filing
Date
(62)
Divisional to
Application :NA
Number :NA
Filing
Date

(71)Name of Applicant
:
**1)Gandhi Institute
for Technology**
Address of
Applicant :Gramadiha,
P.O.: Gangapada, City:
Bhubaneswar, District:
Khurda, Odisha -
752054, India
(72)Name of Inventor :
**1)Mr. BHUPESH
DEKA**
**2)Mr. SITANATH
BISWAS**
**3)Mr. SACHIN
ROUT**
**4)Mr. RITURAJ
BANDHA**
**5)Mr. DURGA
SHANKAR RATH**
**6)Er.
PATITAPABAN
PANDA**
**7)Dr. S KRISHNA
MOHAN RAO**
**8)Dr. PRAVAT
KUMAR SUBUDHI**
**9)Dr. SUJIT
KUMAR PANDA**

(57) Abstract :

The disclosed invention provides a system having a single window portal or application interface to provide access to the schemes of the government to assist the needy people in being aware of the scheme and accessing it. The schemes relevant for a particular person is provided to the person based on the information obtained from the person. The system disclosed herein further provides means to create awareness about the schemes and it also includes means to teach to the novice users about the schemes in various vernacular languages

No. of Pages : 16 No. of Claims : 10

(12) PATENT APPLICATION PUBLICATION

(21) Application
No.201931047034 A

(19) INDIA

(22) Date of filing of Application :19/11/2019

(43) Publication Date :
20/12/2019

(54) Title of the invention : PROCESS FOR MANUFACTURING IMPROVED FIRE RETARDANT AND ANTI-BACTERIAL PLYWOOD

(51)
International :B27D0001040000,B32B0021040000,B27D0001000000,B27D0001060000,B27D0001080000
classification
(31) Priority
Document :NA
No
(32) Priority :NA
Date
(33) Name
of priority :NA
country
(86)
International
Application :NA
No :NA
Filing
Date
(87)
International : NA
Publication
No
(61) Patent
of Addition
to
Application :NA
Number :NA
Filing
Date
(62)
Divisional to
Application :NA
Number :NA
Filing
Date

(71)**Name of Applicant**
:
**1)GREENPLY
INDUSTRIES
LIMITED**
Address of Applicant
:
MADGUL
LOUNGE • , 5TH &
6TH, 23, CHETLA
CENTRAL ROAD,
KOLKATA - 700 027
WEST BENGAL ALSO
AT MAKUM ROAD,
TINSUKIA, ASSAM.
(72)**Name of Inventor** :
1)RAJESH MITTAL

(57) Abstract :

The present invention relates to process of manufacture of fire retardant and anti-bacterial plywood comprising the steps of : Selection of timber; Peeling of veneer from timber; Tenderizing the peeled veneers; Drying the tenderized veneers to achieve upto 8% moisture in the veneers; Conditioning of the dried veneers for 24 hrs; Presetting of veneers through core composing and through panel making; Assembling with phenol formalin glue; Cold pressing (pre-pressing) the assembled veneers to form the base ply shape; Hot pressing the already cold pressed material to make the base ply or MAT ply; Calibration of the base/MAT ply to give it a uniform thickness and a smooth top surface for applying face veneer; Overlaying with face veneer to put a face veneer on top and bottom; Cold pressing the overlaid base ply; Overlying second time with 2 more face to give additional strength; Again, cold pressing the overlaid ply second time; Hot pressing the cold pressed ply; Trimming the edges of the ply to give it a final cut as per market requirement; Sanding the ply to give it a smooth surface; Dipping the ply in preservative solution for anti-borer and anti-termite property addition; Giving it a coating of anti-bacteria solution to kill bacteria in the ply; and marking and stamping the final graded product.

No. of Pages : 19 No. of Claims : 12

(12) PATENT APPLICATION PUBLICATION

(21) Application
No.201931047255 A

(19) INDIA

(22) Date of filing of Application :20/11/2019

(43) Publication Date :
20/12/2019

(54) Title of the invention : NOVEL, ENANTIOMERICALLY ENRICHED OXOISOINDOLIN

(51)
International :C12P0041000000,C07D0207060000,C07D0233540000,C07C0211580000,C07D0257040000
classification
(31) Priority
Document :NA
No
(32) Priority :NA
Date
(33) Name
of priority :NA
country
(86)
International
Application :NA
No :NA
Filing
Date
(87)
International : NA
Publication
No
(61) Patent
of Addition
to
Application :NA
Number :NA
Filing
Date
(62)
Divisional to
Application :NA
Number :NA
Filing
Date

(71)**Name of Applicant**
:
1)Dr Arvind kumar jain
Address of Applicant
:School of Basic and Applied Sciences,
Galgotias University Plot No-2 Sector 17A,
Yamuna Express way,
Grater Noida, Utter Pradesh India -201308
2)Dr Dnyaneshwar Nighot
(72)**Name of Inventor** :
1)Dr Arvind kumar jain
2)Dr Dnyaneshwar Nighot

(57) Abstract :

The present invention discloses Novel, enantiomerically enriched Oxoisoindolin compounds of formula (4).where oxazoline moieties and ketonic moieties are attached to carbon atom adjacent to each other, keto group is at β position from the benzene ring, R1 and R2 are independently hydrogen, optionally alkyl, aryl or optionally substituted poly aryl, optionally substituted lower alkyl, or R1, R2 combined together with carbon atom through which they are attached, from an optionally substituted 6-membered fused aromatic, aliphatic or 5-membered aromatic or aliphatic ring provided that R1 and R2 are attached to carbon atom adjacent to each other; R3 is Alkyl, Aryl, substituted alkyl or aryl, Chloro alkyl or Chloro aryl; or an enantiomeric mixture thereof ; Comprising the step containing an alkyne acylamino alcohol using copper reagent, the present invention efficiently converts the alkyne acylamino alcoholic compound in to highly chemo selective Keto oxazoline compounds with remarkable verity of substrate , mild reaction condition with higher conversion. The present invention discloses Novel, enantiomerically enriched Oxoisoindolin compounds of formula (4).

No. of Pages : 18 No. of Claims : 8

(54) Title of the invention : ZERO RPM-SYNTHESIZED TUNABLE PLASMONIC HOLLOW SILVER NANOSHELLS IN THE FIRST AND SECOND NEAR-IR WINDOWS FOR ENHANCED SOLAR-CATALYSIS

(51) International classification :B82Y0030000000,A61K0041000000,G01N0021552000,A61K0009510000,B22F0001020000
 (31) PriorityDocument No :NA
 (32) PriorityDate :NA
 (33) Nameofprioritycountry :NA
 (86) International Applicaon No :NA
 Filing Date :NA
 (87) International Publication No : NA
 (61) Patent of Addition to :NA
 Application Number :NA
 Filing Date :NA
 (62) Divisional to Application Number :NA
 Filing Date :NA

(71)Name of Applicant :
1)Central University of South Bihar
 Address of Applicant :Central University of South Bihar, SH-7, Gaya-Panchanpur Road, Gaya-824236, India
 (72)Name of Inventor :
1)Amiya Priyam
2)Bhavesh Kumar Dadhich
3)Bhavya Bhushan

(57) Abstract :

Hollow silver nanoshells (HAgNS) having surface plasmon resonances (SPR) in the first and second near-IR window (NIR-I: 650-950 nm; NIR-II:1000-1400 nm) have been synthesized for the first time. A new method based on nanoscale Kirkendall effect has been developed in which dimethylglyoxime (DMG) acts as capping agent as well as growth moderator. Folic Acid (FA) is further added to impart aqueous solubility and stabilization. It finally yields water-soluble, DMG-FA-capped HAgNS. The synthesis process was analyzed for wide range of stirring speeds from zero rpm to 1350 rpm and the synthesis at zero rpm was found to be the best as it yielded HAgNS having narrower SPR band (reduced FWHM) along with greater red-shift of the SPR peak upto 1150 nm in the NIR region. The invention establishes zero-rpm synthesis (no stirring, magnetic or otherwise) as a greener and cost-effective route to obtain 'high quality' HAgNS thereby bringing the energy expenditure to zero. HAgNS exhibits two prominent SPR peaks in the absorption spectra, one corresponding to the quadrupole mode (Q-SPR) and the other symmetric dipole mode (SD-SPR). By deftly controlling the aspect ratio (outer diameter/shell thickness), the dipolar resonances (SD-SPR) have been tuned in a wide NIR range spanning 780 nm to 1150 nm. For the hollow silver nanoshells, this is the maximum red-shift achieved till date in SPR peaks. The spectral range corresponding to 650-1400 nm represents the biologically transparent window which is further divided into two sub-windows: NIR-I ranging from 650-950 and NIR-II ranging from 1000-1400 nm. The latter, i.e. NIR-II window, is more suitable for theranostic applications as scattering becomes very low which means light can penetrate deeper and photothermal efficiency is enhanced. As the SD-SPR is tuned in the NIR II window, the Q-SPR of the HAgNS is concomitantly tuned from 450 to 560 nm in the visible region. Additionally, a less prominent peak is also observed at 330 nm in all these samples which are attributed to antisymmetric dipolar resonances (AD-SPR). Transmission electron microscopy (TEM) revealed that all HAgNS are single-crystal hollow spheres. HAgNSs with tunable plasmon peaks (λ_{SD-SPR}) at 780, 850, 920, 1010, and 1150 nm were synthesized (hence named as HAgNS-780, HAgNS-850, HAgNS-920, HAgNS-1010, and HAgNS-1150, respectively). The corresponding outer diameters were 53 ± 3 , 50 ± 3 , 54 ± 3 , 62 ± 4 , and 40 ± 1 nm as determined by HR-TEM and the aspect ratios (Outer diameter/Shell thickness) were 3.31, 3.33, 3.48, 4.13, and 5.33, respectively. Besides, the HAgNSs were found to be good catalysts in sunlight, for the degradation of dyes, namely, Methyl Orange (MO) and Bromocresol Green (BCG). The solar photocatalytic efficiency of the hollow plasmonic nanoshells, HAgNS-780 and HAgNS-920 were found to be 3.6 and 3.2 times higher, respectively, as compared to solid silver nanospheres (SAgNS-400; $\lambda_{SPR}=400$ nm). Additionally, HAgNS-920 vis-à-vis HAgNS-780 acted as a better catalyst for BCG within NIR window. Thus, the NIR window of the solar spectrum displayed greater efficiency with HAgNSs as plasmonic photocatalysts. The invention will open up new vistas in faster and effective remediation of dye-effluents emanating from the textile industry.

No. of Pages : 17 No. of Claims : 10

(12) PATENT APPLICATION PUBLICATION

(21) Application
No.201931047641 A

(19) INDIA

(22) Date of filing of Application :21/11/2019

(43) Publication Date :
20/12/2019

(54) Title of the invention : TRANSFORMATION OF FLY ASH INTO NON-TOXIC, HIGH WATER ABSORBING POLYMER FOR DROUGHT MANAGEMENT.

(51)
International :A61L001560000,C08F000230000,A61F0002140000,C04B0018080000,C08L0033260000
classification

(31) Priority
Document :NA
No

(32) Priority :NA
Date

(33) Name
of priority :NA
country

(86)
International
Application :NA
No :NA

Filing
Date

(87)
International : NA
Publication
No

(61) Patent
of Addition
to
Application :NA
Number :NA
Filing

Date

(62)
Divisional to
Application :NA
Number :NA
Filing

Date

(71)Name of Applicant :
**1)INDIAN
INSTITUTE OF
TECHNOLOGY
GUWAHATI**

Address of Applicant
:Indian Institute of
Technology Guwahati,
Guwahati Assam India
781039

(72)Name of Inventor :
**1)SAHA, Abhisekh
2)SEKHARAN, Dr.
Sreedeeep
3)MANNA, Dr. Uttam**

(57) Abstract :

The invention relates to a method of preparation flyash containing high water adsorption hydrogel material and its application for drought management. The method comprises polymerization of acrylate monomers in presence of fly ash and crosslinker by free radical polymerization method. The resulting high water adsorption hydrogel exhibits superior water absorption capacity than the corresponding polyacrylates and flyash (basically no water-absorbing material) and a mixture of the two. The invention offers a low cost environment friendly method to covert waste material into eco-friendly material for effective drought control.

No. of Pages : 32 No. of Claims : 11

(12) PATENT APPLICATION PUBLICATION

(21) Application
No.201931048105 A

(19) INDIA

(22) Date of filing of Application :25/11/2019

(43) Publication Date :
20/12/2019

(54) Title of the invention : INTELLIGENT ELECTRICITY SAVING DEVICE

(51)
International :H04N0013282000,H01R0013660000,F24C0007080000,H01R0024780000,B63J0002120000
classification

(31) Priority
Document :NA
No

(32) Priority
Date :NA

(33) Name
of priority :NA
country

(86)
International
Application :NA
No :NA

Filing
Date

(87)
International
Publication : NA
No

(61) Patent
of Addition
to
Application :NA
Number :NA

Filing
Date

(62)
Divisional to
Application :NA
Number :NA

Filing
Date

(71)Name of Applicant :
**1)Dr. Munesh
Chandra Trivedi**

Address of Applicant
:Department of Computer
Science & Engineering,
National Institute of
Technology, Agartala,
P.O.: NIT Agartala,
Barjala, Jirania,
TRIPURA (W), India

**2)Dr. Amit Shastri
3)Dr. Vikas Kumar
Singh
4)Dr. Anurag Aeron
5)Dr. Amit Kumar
Agarwal**

**6)Prashant Bhardwaj
7)Ms. Soumya Trivedi**

(72)Name of Inventor :
**1)Dr. Munesh
Chandra Trivedi
2)Dr. Amit Shastri
3)Dr. Vikas Kumar
Singh
4)Dr. Anurag Aeron
5)Dr. Amit Kumar
Agarwal**

**6)Prashant Bhardwaj
7)Ms. Soumya Trivedi**

(57) Abstract :

The present invention relates to the intelligent electricity saving device. Further, it relates to an electric energy saving and monitoring system and methods thereof. The electric energy saving and monitoring system and methods thereof comprise of intelligent electricity saving device, at least one camera, at least one fan, plurality of lights, plurality of electrical appliance, plurality of electronic appliance, at least one external electrical source, at least one network unit, at least one storage unit, at least one temperature sensor, at least one motion sensor, at least one light sensor and a computer implemented methods. The network unit further comprise of plurality of switch, at least one router and network connectivity.

No. of Pages : 28 No. of Claims : 10

(12) PATENT APPLICATION PUBLICATION

(21) Application
No.201931048224 A

(19) INDIA

(22) Date of filing of Application :25/11/2019

(43) Publication Date :
20/12/2019

(54) Title of the invention : A SIXTH SENSE DEVICE

(51)
International :H04W0004800000,H04L0029080000,G06F0021350000,H04W0004700000,H03K0007080000
classification
(31) Priority
Document :NA
No
(32) Priority :NA
Date
(33) Name
of priority :NA
country
(86)
International
Application :NA
No :NA
Filing
Date
(87)
International
Publication : NA
No
(61) Patent
of Addition
to
Application :NA
Number :NA
Filing
Date
(62)
Divisional to
Application :NA
Number :NA
Filing
Date

(71)Name of
Applicant :
**1)Dr. Munesh
Chandra Trivedi**
Address of
Applicant :Department
of Computer Science &
Engineering, National
Institute of
Technology, Agartala,
P.O.: NIT Agartala,
Barjala, Jirania,
TRIPURA (W), India
2)Dr. Amit Shastri
**3)Dr. Amit Kumar
Agarwal**
**4)Ms. Lalita
Kumari**
5)Vikas Somani
**6)Ms. Soumya
Trivedi**
(72)Name of Inventor
:
**1)Dr. Munesh
Chandra Trivedi**
2)Dr. Amit Shastri
**3)Dr. Amit Kumar
Agarwal**
**4)Ms. Lalita
Kumari**
5)Vikas Somani
**6)Ms. Soumya
Trivedi**

(57) Abstract :

The invention relates to a sixth sense device for identifying data from at least one of an internet or hard drive based on a received input data, said sixth sense device comprising: a camera; a communication drive; a power plug button; a microphone; a text converter; a voice converter; a memory element; and an IOT (internet of things) connecting point. The camera and said microphone receive real time said input data and the communication drive may include at least one of a wi-fi drive, a Bluetooth drive, an RF drive or the like which is communicatively coupled with an IOT device. The device may further include a mobile application to communicate with said IOT device. Moreover, the device may generate an alert message when said sixth sense device identify a criminal activity in said input data. Hence, the device may fetches all information from internet relevant to said input data to provide complete detail of input data.

No. of Pages : 25 No. of Claims : 10

(12) PATENT APPLICATION PUBLICATION

(21) Application
No.201931049330 A

(19) INDIA

(22) Date of filing of Application :30/11/2019

(43) Publication Date :
20/12/2019

(54) Title of the invention : FOOD SPOILAGE DETECTION DEVICE

(51)
International :G01N0033020000,C12Q0001040000,A23L0003350800,A61K0035741000,H01L0051050000
classification

(31) Priority
Document :NA
No

(32) Priority :NA
Date

(33) Name
of priority :NA
country

(86)
International
Application :NA
No :NA

Filing
Date

(87)
International :NA
Publication
No

(61) Patent
of Addition
to :NA
Application :NA
Number :NA

Filing
Date

(62)
Divisional to
Application :NA
Number :NA

Filing
Date

(71)Name of Applicant
:

**1)Dr. Munesh
Chandra Trivedi**
Address of
Applicant :Department
of Computer Science &
Engineering, National
Institute of Technology,
Agartala, P.O.: NIT
Agartala, Barjala,
Jirania, TRIPURA (W),
India

**2)Dr. Amit Shastri
3)Dr. Amit Kumar
Agarwal
4)Dr. Vikas Kumar
Singh
5)Dr. Anurag Aeron
6)Prashant Bhardwaj
7)Ms. Soumya**

**Trivedi
8)Dr. Chandresh
Kumar Chhatlani**

(72)Name of Inventor :
**1)Dr. Munesh
Chandra Trivedi
2)Dr. Amit Shastri
3)Dr. Amit Kumar
Agarwal
4)Dr. Vikas Kumar
Singh**

**5)Dr. Anurag Aeron
6)Prashant Bhardwaj
7)Ms. Soumya
Trivedi
8)Dr. Chandresh
Kumar Chhatlani**

(57) Abstract :

The present invention discloses a Food spoilage detection device 100 for detecting bacteria and its growth. The food spoilage detection device comprising a variety of sensors, electronic components, and plurality of biocompatible organic field effect transistors. The food spoilage detection device is capable of finding a presence of bacteria, type of bacteria, and also bacteria count by combining the data of microbial data, physical data and chemical data. The device is easy to use and it can be used by two different modes, such as invasive technology and non-invasive technology. A method of detecting spoilage of a food product by monitoring bacteria presence, type of bacteria and bacterial growth is also disclosed.

No. of Pages : 24 No. of Claims : 10

(54) Title of the invention : BORON NITRIDE NANO SHEETS(BNNS) FROM HEXAGONAL BORON NITRIDE BY AQUEOUS BI-THERMAL EXFOLIATION PROTOCOL

(51) International Classification : C01B0021064000, C08K0003380000, C04B0035583000, B82Y0040000000, C04B0035583300

(31) Priority Document No : NA

(32) Priority Date : NA

(33) Name of priority country : NA

(86) International Application No : NA

Filing Date : NA

(87) International Publication No : NA

(61) Patent of Addition to Application Number : NA

Filing Date : NA

(62) Divisional to Application Number : NA

Filing Date : NA

(71) Name of Applicant :
1) SIKSHA 'O' ANUSANDHAN DEEMED TO BE UNIVERSITY
 Address of Applicant : JAGAMOHAN NAGAR, JAGAMARA, BHUBANESWAR, ODISHA-751030, INDIA.

(72) Name of Inventor :
1) KULAMANI PARIDA
2) SAMBHU PRASAD PATTNAIK
3) ARJUN BEHERA
4) PRADEEPTA BABU
5) LOPAMUDRA ACHARYA
6) RASHMI ACHARYA

(57) Abstract :

The present invention provides a process for making a two-dimensional material (Boron Nitride Nano Sheets) out of a bulk of three-dimensional layered hexagonal Boron Nitride in an environment friendly process using only water as exfoliant. The process is facile, low cost, scalable and suitable for industrial applications. The process comprises of contacting a three-dimensional layered material h-BN with water (with or without common salt) under repeated cycles of bi-thermal condition to form a two-dimensional material, wherein the three-dimensional material is a hexagonal Boron Nitride and wherein no other chemical is used in the process. We have obtained two-dimensional materials like nanosheets of hexagonal Boron Nitride (BNNSs) by the said process.

No. of Pages : 20 No. of Claims : 10

(12) PATENT APPLICATION PUBLICATION

(21) Application
No.201931049524 A

(19) INDIA

(22) Date of filing of Application :02/12/2019

(43) Publication Date :
20/12/2019

(54) Title of the invention : CLEANING COMPOSITION COMPRISING GYMNOCLADUS POD EXTRACT

(51)
International :C11D0011000000,A61K0008970000,A47L0011400000,C11D0003200000,C11D0001120000
classification
(31) Priority
Document :NA
No
(32) Priority :NA
Date
(33) Name
of priority :NA
country
(86)
International
Application :PCT//
No :01/01/1900
Filing
Date
(87)
International
Publication : NA
No
(61) Patent
of Addition
to
Application :NA
Number :NA
Filing
Date
(62)
Divisional to
Application :NA
Number :NA
Filing
Date

(71)**Name of Applicant**
:
1)PAYUM, Temin
Address of
Applicant :Jawaharlal
Nehru College, Pasighat
Department of Botany,
East Siang Dist,
Arunachal Pradesh -
791103, India.
(72)**Name of Inventor :**
1)PAYUM, Temin

(57) Abstract :

The present invention generally relates to a cleaning composition. Specifically, the present invention relates to a cleaning composition comprising of Gymnocladus pod extract for cleaning variety of hard and soft surfaces. The present invention provides method for extraction of Gymnocladus pod extract and manufacturing the composition comprising of Gymnocladus pod extract.

No. of Pages : 21 No. of Claims : 11

(12) PATENT APPLICATION PUBLICATION

(21) Application No.201931051970
A

(19) INDIA

(22) Date of filing of Application :15/12/2019

(43) Publication Date : 20/12/2019

(54) Title of the invention : SYSTEM AND METHOD OF INTEGRATING AUGMENTED AND VIRTUAL REALITY WITH VOICE RECOGNITION

(51)
International :G06T0019000000,G06Q0050000000,G06F0003010000,G10L0015220000,F16K0037000000
classification
(31) Priority
Document :NA
No
(32) Priority :NA
Date
(33) Name
of priority :NA
country
(86)
International
Application :PCT//
No :01/01/1900
Filing
Date
(87)
International : NA
Publication
No
(61) Patent
of Addition
to
Application :NA
Number :NA
Filing
Date
(62)
Divisional to
Application :NA
Number :NA
Filing
Date

(71)Name of Applicant :
1)ABHIJIT SARKAR
Address of Applicant :24A, Railway
Old Type II Colony, Jhaljhalia Malda,
Near Railway Hospital, West Bengal -
732102
(72)Name of Inventor :
1)ABHIJIT SARKAR

(57) Abstract :

The present invention envisages integration of Augmented Reality and Virtual Reality together, along with voice recognition. The present disclosure also envisages a system wherein user is offered resource material in both AR and VR platforms, integrated in a single device. The present invention aims to enable a user to view the resource material in AR or VR or toggle between the modes. Further, the present invention permits the user to manipulate objects through voice commands.

No. of Pages : 20 No. of Claims : 10

CONTINUED TO PART- 2

(12) PATENT APPLICATION PUBLICATION

(21) Application No.202241021106 A

(19) INDIA

(22) Date of filing of Application :08/04/2022

(43) Publication Date : 29/04/2022

(54) Title of the invention : AN EFFICIENT PORTABLE REMOTE APPLICATION FOR VEHICLE PARKING SYSTEM

(51) International classification :G06Q0010020000, G08G0001140000, G06Q0030060000, G07B0015020000, H04W0012060000

(86) International Application No :NA
 Filing Date :NA

(87) International Publication No : NA

(61) Patent of Addition to Application Number :NA
 Filing Date :NA

(62) Divisional to Application Number :NA
 Filing Date :NA

(71)Name of Applicant :
1)HINDUSTHAN COLLEGE OF ENGINEERING AND TECHNOLOGY
 Address of Applicant :HINDUSTHAN COLLEGE OF ENGINEERING AND TECHNOLOGY, VALLEY CAMPUS, POLLACHI HIGHWAY, COIMBATORE, TAMIL NADU, INDIA - 641032. -----

Name of Applicant : NA
Address of Applicant : NA

(72)Name of Inventor :
1)Dr. I. JASMINE SELVAKUMARI JEYA
 Address of Applicant :PROFESSOR & HEAD-IT, HINDUSTHAN COLLEGE OF ENGINEERING AND TECHNOLOGY, VALLEY CAMPUS, POLLACHI HIGHWAY, COIMBATORE, TAMIL NADU, INDIA - 641032. -----

2)Ms. P. REVATHI
 Address of Applicant :ASSISTANT PROFESSOR/IT, HINDUSTHAN COLLEGE OF ENGINEERING AND TECHNOLOGY, VALLEY CAMPUS, POLLACHI HIGHWAY, COIMBATORE, TAMIL NADU, INDIA - 641032. -----

3)BETSIN KURUVILA MEKKAT
 Address of Applicant :HINDUSTHAN COLLEGE OF ENGINEERING AND TECHNOLOGY, VALLEY CAMPUS, POLLACHI HIGHWAY, COIMBATORE, TAMIL NADU, INDIA - 641032. -----

4)DEVANARAYANAN.P
 Address of Applicant :HINDUSTHAN COLLEGE OF ENGINEERING AND TECHNOLOGY, VALLEY CAMPUS, POLLACHI HIGHWAY, COIMBATORE, TAMIL NADU, INDIA - 641032. -----

5)HARI KRISHNA. J
 Address of Applicant :HINDUSTHAN COLLEGE OF ENGINEERING AND TECHNOLOGY, VALLEY CAMPUS, POLLACHI HIGHWAY, COIMBATORE, TAMIL NADU, INDIA - 641032. -----

6)JAGAN Y
 Address of Applicant :HINDUSTHAN COLLEGE OF ENGINEERING AND TECHNOLOGY, VALLEY CAMPUS, POLLACHI HIGHWAY, COIMBATORE, TAMIL NADU, INDIA - 641032. -----

(57) Abstract :
 :• Vehicle Management System has mainly two types of users, Admin and Customers. ■ ■There is only-one Admin in this software. Admin can add new users to software. The software is intended to do two major tasks i.e. Booking Management and Slot Management. Once the customer selects the parking space, they can reserve it by providing information ■such as vehicle type (bike, car, etc.), license number, arrival time, departure time, date. The customer can cancel their booking by providing the name of the selected parking space. Booking Management keeps track of all the vehicle bookings related transactions. It includes .New Vehicle Registration, Checking Availability, Booking Vehicles, Booking Cancellation, .Payment and Booking History. While in Slot Management, user can browse the parking lots and book a desired ■ parking space. This-will be used to manage the parking lot information. Parking lot consists of a group of parking spaces. Once a user books a slot for a particular date, that slot will be . unavailable for. other users for that date. This will include a graphical view of the parking lot. Every parking space will have a unique parking id and parking name. Here, the logged in customer and admin should be able to view the parking status i.e. whether parking space is -available or already reserved.

No. of Pages : 5 No. of Claims : 5

(12) PATENT APPLICATION PUBLICATION

(21) Application No.202241020883 A

(19) INDIA

(22) Date of filing of Application :07/04/2022

(43) Publication Date : 29/04/2022

(54) Title of the invention : AN INTELLIGENT CHABOT FOR STUDENT CAREER COUNSELING

(51) International classification :G06Q0050200000, G06N0003000000, G06Q0010100000, G06N0020000000, H04L0012580000

(86) International Application No :NA
Filing Date :NA

(87) International Publication No : NA

(61) Patent of Addition to Application Number :NA
Filing Date :NA

(62) Divisional to Application Number :NA
Filing Date :NA

(71)Name of Applicant :

1)HINDUSTHAN COLLEGE OF ENGINEERING AND TECHNOLOGY

Address of Applicant :HINDUSTHAN COLLEGE OF ENGINEERING AND TECHNOLOGY, VALLEY CAMPUS, POLLACHI HIGHWAY, COIMBATORE, TAMIL NADU, INDIA - 641032. -----

Name of Applicant : NA

Address of Applicant : NA

(72)Name of Inventor :

1)Dr. I. JASMINE SELVAKUMARI JEYA

Address of Applicant :PROFESSOR & HEAD-IT, HINDUSTHAN COLLEGE OF ENGINEERING AND TECHNOLOGY, VALLEY CAMPUS, POLLACHI HIGHWAY, COIMBATORE, TAMIL NADU, INDIA - 641032. -----

2)Ms. P. ANITHA

Address of Applicant :ASSISTANT PROFESSOR/IT, HINDUSTHAN COLLEGE OF ENGINEERING AND TECHNOLOGY, VALLEY CAMPUS, POLLACHI HIGHWAY, COIMBATORE, TAMIL NADU, INDIA - 641032. -----

3)AJIT A

Address of Applicant :HINDUSTHAN COLLEGE OF ENGINEERING AND TECHNOLOGY, VALLEY CAMPUS, POLLACHI HIGHWAY, COIMBATORE, TAMIL NADU, INDIA - 641032. -----

4)CHINNADURAI S

Address of Applicant :HINDUSTHAN COLLEGE OF ENGINEERING AND TECHNOLOGY, VALLEY CAMPUS, POLLACHI HIGHWAY, COIMBATORE, TAMIL NADU, INDIA - 641032. -----

5)HARIHARAN R

Address of Applicant :HINDUSTHAN COLLEGE OF ENGINEERING AND TECHNOLOGY, VALLEY CAMPUS, POLLACHI HIGHWAY, COIMBATORE, TAMIL NADU, INDIA - 641032. -----

6)KAILASH S

Address of Applicant :HINDUSTHAN COLLEGE OF ENGINEERING AND TECHNOLOGY, VALLEY CAMPUS, POLLACHI HIGHWAY, COIMBATORE, TAMIL NADU, INDIA - 641032. -----

(57) Abstract :

The Chabot is a software application, which is used to conduct a conversation using text or conversation with users. It can exactly behave as a person as a conversational partner. Bots are Artificial-Intelligence based software, which behaves like humans and is more efficient and faster than human beings are. This project will describe current efforts in the development of an intelligent Career Counseling Bot. Career Counseling project is built using artificial intelligence algorithms that are used for analyzing users queries and understand user's message. It provides some valid result to the query of the user. The User can query any career related query through the system. The user does not have to personally go to career counsellor for the same. The System analyses the question and then answers to the query as if the counsellor answers it. This system helps the user to choose the right career that they should follow according to their interests and capabilities. This project involves an AI based expert system, which helps the students to give a basic idea of possible career opportunities. This project will help the students by taking into consideration, the student's interest and aptitude test result. An Intelligent Career Counseling Bot will help the user in selecting the right career by giving a proper response to the user's query. By analyzing these bots we concluded that there exists no system that can act as a virtual mentor and help students whenever needed

No. of Pages : 6 No. of Claims : 5

(12) PATENT APPLICATION PUBLICATION

(21) Application No.202241021445 A

(19) INDIA

(22) Date of filing of Application :11/04/2022

(43) Publication Date : 29/04/2022

(54) Title of the invention : ANDROID SAFETY APPLICATION USING GPS AND MESSAGING SYSTEM

(51) International classification :G08B0025010000, G08B0021020000, H04W0004900000, G08B0025080000, G10L0015220000

(86) International Application No :NA
 Filing Date :NA

(87) International Publication No : NA

(61) Patent of Addition to Application Number :NA
 Filing Date :NA

(62) Divisional to Application Number :NA
 Filing Date :NA

(71)Name of Applicant :

1)HINDUSTHAN COLLEGE OF ENGINEERING AND TECHNOLOGY

Address of Applicant : HINDUSTHAN COLLEGE OF ENGINEERING AND TECHNOLOGY, VALLEY CAMPUS, POLLACHI HIGHWAY, COIMBATORE, TAMIL NADU, INDIA - 641032. -----

Name of Applicant : NA

Address of Applicant : NA

(72)Name of Inventor :

1)Dr. I. JASMINE SELVAKUMARI JEYA

Address of Applicant : PROFESSOR & HEAD-IT, HINDUSTHAN COLLEGE OF ENGINEERING AND TECHNOLOGY, VALLEY CAMPUS, POLLACHI HIGHWAY, COIMBATORE, TAMIL NADU, INDIA - 641032. -----

2)Ms. K. KAVITHA

Address of Applicant :ASSISTANT PROFESSOR/ IT, HINDUSTHAN COLLEGE OF ENGINEERING AND TECHNOLOGY, VALLEY CAMPUS, POLLACHI HIGHWAY, COIMBATORE, TAMIL NADU, INDIA - 641032. -----

3)AJAY KUMAR J.S

Address of Applicant :HINDUSTHAN COLLEGE OF ENGINEERING AND TECHNOLOGY, VALLEY CAMPUS, POLLACHI HIGHWAY, COIMBATORE, TAMIL NADU, INDIA - 641032. -----

4)LOKESH S

Address of Applicant :HINDUSTHAN COLLEGE OF ENGINEERING AND TECHNOLOGY, VALLEY CAMPUS, POLLACHI HIGHWAY, COIMBATORE, TAMIL NADU, INDIA - 641032. -----

5)MOHAMED ASHIF

Address of Applicant :HINDUSTHAN COLLEGE OF ENGINEERING AND TECHNOLOGY, VALLEY CAMPUS, POLLACHI HIGHWAY, COIMBATORE, TAMIL NADU, INDIA - 641032. -----

6)NAVEEN KUMAR P

Address of Applicant :HINDUSTHAN COLLEGE OF ENGINEERING AND TECHNOLOGY, VALLEY CAMPUS, POLLACHI HIGHWAY, COIMBATORE, TAMIL NADU, INDIA - 641032. -----

(57) Abstract :

In today's world, people using smart phones have increased rapidly and hence, a smart phone can be used efficiently for personal security or various other protection purposes. An advanced system is needed to serve the purpose of getting help as soon as possible. When you need some personal assistance, you can actually turn on your phone and can call or message someone for help. But in a life-threatening emergency like attack, sexual assault, robbery, harassment, accident, fire, birth assistance, we don't have time to open our phone, instead, we need some accessibility methods by which we can reach out for help without actually operating the phone. It is an application for android safety though men can also use it at a distressed situation. Voice command or SOS key can activate it. An alert message with location is sent to the userdefined numbers in every five minutes until the system is turned off. Many cases remain mysterious due to insufficient evidence. So, we have kept audio and video recording option to keep evidence. Continuous location tracking, showing the victim safe zone, offline mode is some of the most useful features of this system. This android application is not only for women safety like of others but this is something different that this application can be used in all kind of emergency situation like (fire accident, medical emergency, etc.). The unique feature of this application is to send the message to the police or other emergency agencies continuously for every five minutes until the stop button in the application is clicked. Continuous location tracking information via SMS helps to find the location of the victim quickly and can be rescued safely.

No. of Pages : 5 No. of Claims : 5

पेटेंट कार्यालय
शासकीय जर्नल

**OFFICIAL JOURNAL
OF
THE PATENT OFFICE**

निर्गमन सं. 24/2021
ISSUE NO. 24/2021

शुक्रवार
FRIDAY

दिनांक: 11/06/2021
DATE: 11/06/2021

पेटेंट कार्यालय का एक प्रकाशन
PUBLICATION OF THE PATENT OFFICE

INTRODUCTION

In view of the recent amendment made in the Patents Act, 1970 by the Patents (Amendment) Act, 2005 effective from 01st January 2005, the Official Journal of The Patent Office is required to be published under the Statute. This Journal is being published on weekly basis on every Friday covering the various proceedings on Patents as required according to the provision of Section 145 of the Patents Act 1970. All the enquiries on this Official Journal and other information as required by the public should be addressed to the Controller General of Patents, Designs & Trade Marks. Suggestions and comments are requested from all quarters so that the content can be enriched.

(Shri Rajendra Ratnoo)
CONTROLLER GENERAL OF PATENTS, DESIGNS & TRADE MARKS

11th JUNE, 2021

CONTENTS

<i>SUBJECT</i>	<i>PAGE NUMBER</i>
JURISDICTION	: 26082-26083
SPECIAL NOTICE	: 26084-26085
EARLY PUBLICATION (DELHI)	: 26086-26128
EARLY PUBLICATION (MUMBAI)	: 26129-26157
EARLY PUBLICATION (CHENNAI)	: 26158-26392
EARLY PUBLICATION (KOLKATA)	: 26393-26402
PUBLICATION AFTER 18 MONTHS (DELHI)	: 26403-26542
PUBLICATION AFTER 18 MONTHS (MUMBAI)	: 26543-26610
PUBLICATION AFTER 18 MONTHS (CHENNAI)	: 26611-26999
PUBLICATION AFTER 18 MONTHS (KOLKATA)	: 27000-27063
WEEKLY ISSUED FER (DELHI)	: 27064-27106
WEEKLY ISSUED FER (MUMBAI)	: 27107-27135
WEEKLY ISSUED FER (CHENNAI)	: 27136-27176
WEEKLY ISSUED FER (KOLKATA)	: 27177-27187
PUBLICATION UNDER SECTION 43(2) IN RESPECT OF THE GRANT (DELHI)	: 27188-27204
PUBLICATION UNDER SECTION 43(2) IN RESPECT OF THE GRANT (MUMBAI)	: 27205-27212
PUBLICATION UNDER SECTION 43(2) IN RESPECT OF THE GRANT (CHENNAI)	: 27213-27230
PUBLICATION UNDER SECTION 43(2) IN RESPECT OF THE GRANT (KOLKATA)	: 27231-27239
INTRODUCTION TO DESIGN PUBLICATION	: 27240
REGISTRATION OF DESIGNS	: 27241-27275

**THE PATENT OFFICE
KOLKATA, 11/06/2021**

Address of the Patent Offices/Jurisdictions

The following are addresses of all the Patent Offices located at different places having their Territorial Jurisdiction on a Zonal basis as shown below:-

<p>1 Office of the Controller General of Patents, Designs & Trade Marks, Boudhik Sampada Bhavan, Near Antop Hill Post Office,S.M.Road,Antop Hill, Mumbai - 400 037</p> <p>Phone: (91)(22) 24123311, Fax : (91)(22) 24123322 E-mail: cgpdtm@nic.in</p>	<p>4 The Patent Office, Government of India, Intellectual Property Rights Building, G.S.T. Road, Guindy, Chennai - 600 032.</p> <p>Phone: (91)(44) 2250 2081-84 Fax : (91)(44) 2250 2066 E-mail: chennai-patent@nic.in</p> <p>❖ The States of Andhra Pradesh, Telangana, Karnataka, Kerala, Tamil Nadu and the Union Territories of Puducherry and Lakshadweep.</p>
<p>2 The Patent Office, Government of India, Boudhik Sampada Bhavan, Near Antop Hill Post Office,S.M.Road,Antop Hill, Mumbai - 400 037</p> <p>Phone: (91)(22) 24137701 Fax: (91)(22) 24130387 E-mail: mumbai-patent@nic.in</p> <p>❖ The States of Gujarat, Maharashtra, Madhya Pradesh, Goa and Chhattisgarh and the Union Territories of Daman and Diu & Dadra and Nagar Haveli</p>	<p>5 The Patent Office (Head Office), Government of India, Boudhik Sampada Bhavan, CP-2, Sector -V, Salt Lake City, Kolkata- 700 091</p> <p>Phone: (91)(33) 2367 1943/44/45/46/87 Fax: (91)(33) 2367 1988 E-Mail: kolkata-patent@nic.in</p> <p>❖ Rest of India</p>
<p>3 The Patent Office, Government of India, Boudhik Sampada Bhavan, Plot No. 32., Sector-14, Dwarka, New Delhi - 110075</p> <p>Phone: (91)(11) 25300200 & 28032253 Fax: (91)(11) 28034301 & 28034302 E.mail: delhi-patent@nic.in</p> <p>❖ The States of Haryana, Himachal Pradesh, Jammu and Kashmir, Punjab, Rajasthan, Uttar Pradesh, Uttaranchal, Delhi and the Union Territory of Chandigarh.</p>	

Website: www.ipindia.nic.in

www.patentoffice.nic.in

All applications, notices, statements or other documents or any fees required by the Patents Act, 1970 and The Patents (Amendment) Act, 2005 or by the Patents (Amendment) Rules, 2006 will be received only at the appropriate offices of the Patent Office.

Fees: The Fees may either be paid in cash or may be sent by Bank Draft or Cheques payable to the Controller of Patents drawn on a scheduled Bank at the place where the appropriate office is situated.

पेटेंट कार्यालय
कोलकाता, दिनांक 11/06/2021

• कार्यालयों के क्षेत्राधिकार के पते

विभिन्न जगहों पर स्थित पेटेंट कार्यालय के पते आंचलिक आधार पर दर्शित उनके प्रादेशिक अधिकार क्षेत्र के साथ नीचे दिए गए हैं:-

<p>1 कार्यालय : महानियंत्रक, एकस्व, अभिकल्प तथा व्यापार चिह्न, एंटोप हिल डाकघर के समीप, एस. एम. रोड, एंटोप हिल, मुम्बई- 400 037, भारत, फोन: (91) (22) 24123311 फ़ैक्स: (91) (22) 24123322 ई. मेल: cgpdtm@nic.in</p>	<p>4 पेटेंट कार्यालय, भारत सरकार इंटेलेक्चुअल प्रॉपर्टी राइट्स बिल्डिंग, इंडस्ट्रियल इस्टेट एसआईडीसीओ आरएमडी गोडाउन एरिया एडजसेन्ट टु ईगल फ्लास्क, जी. एस. टी. रोड, गायन्डी चेन्नई - 600 032. फोन: (91) (44) 2250 2081-84 फ़ैक्स: (91) (44) 2250-2066 ई. मेल: chennai-patent@nic.in ❖ आन्ध्र प्रदेश, तेलंगाना, कर्नाटक, केरल, तमिलनाडु तथा पुडुचेरी राज्य क्षेत्र एवं संघ शासित क्षेत्र, लक्षदीप</p>
<p>2 पेटेंट कार्यालय, भारत सरकार बौद्धिक संपदा भवन, एंटोप हिल डाकघर के समीप, एस. एम. रोड, एंटोप हिल, मुम्बई- 400 037, फोन: (91) (22) 24137701 फ़ैक्स: (91) (22) 24130387 ई. मेल: Mumbai-patent@nic.in ❖ <input type="checkbox"/> गुजरात, महाराष्ट्र, मध्य प्रदेश, गोवा तथा छत्तीसगढ़ राज्य क्षेत्र एवं संघ शासित क्षेत्र, दमन तथा दीव, दावर और नगर हवेली.</p>	<p>5 पेटेंट कार्यालय, भारत सरकार कोलकाता, (प्रधान कार्यालय) बौद्धिक संपदा भवन, सीपी-2, सेक्टर- V, साल्ट लेक सिटी, कोलकाता-700 091, भारत. फोन: (91) (33) 2367 1943/44/45/46/87 फ़ैक्स:/Fax: (91) (33) 2367 1988 ई. मेल: kolkata-patent@nic.in ❖ भारत का अवशेष क्षेत्र</p>
<p>3 पेटेंट कार्यालय, भारत सरकार बौद्धिक संपदा भवन, प्लॉट सं. 32, सेक्टर- 14, द्वारका, नई दिल्ली- 110 075. फोन: (91) (11) 25300200, 28032253 फ़ैक्स: (91) (11) 28034301, 28034302 ई. मेल: delhi-patent@nic.in हरियाणा, हिमाचल प्रदेश, जम्मू तथा कश्मीर, पंजाब, राजस्थान, उत्तर प्रदेश, दिल्ली तथा उत्तरांचल राज्य क्षेत्रों, एवं संघ शासित क्षेत्र चंडीगढ़</p>	

वेबसाइट: <http://www.ipindia.nic.in>
www.patentoffice.nic.in

पेटेंट अधिनियम, 1970 तथा पेटेंट (संशोधन) अधिनियम, 2005 अथवा पेटेंट (संशोधन) नियम, 2006 द्वारा वांछित सभी आवेदन, सूचनाएं, विवरण या अन्य दस्तावेज़ या कोई शुल्क पेटेंट कार्यालय के केवल उपयुक्त कार्यालय में स्वीकृत होंगे। शुल्क: शुल्क या तो नगद रूप में या Controller of Patents के नाम में देय बैंक ड्राफ्ट या चेक के द्वारा भेजी जा सकती है जो उसी स्थान के किसी अनुसूचित बैंक में प्रदत्त हो जहाँ उपयुक्त कार्यालय स्थित है।

SPECIAL NOTICE

18 Months publication as required under Section 11A of the Patents Act, 1970 as amended by the Patents (Amendment) Act, 2005.

Notice is hereby given that any person at any time before the grant of Patent may give representation by way of opposition to the Controller of Patents at appropriate office on the ground and in a manner specified under section 25(1) of the Patents (Amendment) Act, 2005 read with Rule 55 of the Patents (Amendment) Rules, 2006.

Notice is also given that if any interested person requests for copies of the complete specification, drawing and abstract of any application already published, the photocopy of the same can be supplied by the Patent Office as per the jurisdiction on payment of prescribed fees of Rs.8/- per page. If any further details are required to be obtained, the same can be provided by the respective Patent Offices on request.

(Shri Rajendra Ratnoo)
CONTROLLER GENERAL OF PATENTS, DESIGNS & TRADE MARKS

SPECIAL NOTICE

Under the new provision of the Patents Act, 1970 as amended by the Patents (Amendment) Act, 2005 and Rules there under, Publication of the matter relating to Patents in the Official Gazette of India Part III, Section 2 has been discontinued and instead The Official Journal of the Patent Office is being published containing all the activities of The Patent Office such as publication of all the patent applications after 18th months , grant of patents & all other information in respect of the proceedings as required under the provisions of the Patents (Amendment) Act, 2005 and Rules thereunder on weekly basis on every **Friday**.

The Journal is uploaded in the website every Friday. So Paper form and CD-ROM form of the Journal are discontinued from 01/01/2009.

SPECIAL NOTICE

Every effort is being taken to publish all the patent applications under section 11(A) of the Patents Act. However, if duplication of publication of any application is found, then earlier date of publication will be taken for the purpose of provisional protection for applicant and Patent Office will grant Patent not before six months from the date of second publication, provided that there is there is no third party representation.

Early Publication:

The following patent applications have been published under section 11A (2) of The Patents (Amendment) Act 2005 and rule 24A of The Patents (Amendment) Rules, 2006. Any person may file representation by way of opposition to the Controller of Patents at the appropriate office against the grant of the patent in the prescribed manner under section 25(1) of the Patents (Amendment) Act 2005 read with the rule 55 of The Patents (Amendment) Rules, 2006:

(12) PATENT APPLICATION PUBLICATION

(21) Application No.202011007304 A

(19) INDIA

(22) Date of filing of Application :20/02/2020

(43) Publication Date : 11/06/2021

(54) Title of the invention : AN ULTRAFAST RESISTIVE TYPE HUMIDITY SENSOR BASED ON NANOHYBRIDS'

(51) International classification	:G06F0003045000, G01N0027120000, G11C0013000000, G11C0011160000, H01F0027320000	(71) Name of Applicant : 1)INDIAN INSTITUTE OF TECHNOLOGY, ROORKEE Address of Applicant :ROORKEE UTTARAKHAND- 247667, INDIA Uttarakhand India
(31) Priority Document No	:NA	(72) Name of Inventor :
(32) Priority Date	:NA	1)ATUL KUMAR
(33) Name of priority country	:NA	2)PROF. ANIL KUMAR
(86) International Application No	:NA	3)PROF. G.D. VARMA
Filing Date	:NA	
(87) International Publication No	: NA	
(61) Patent of Addition to Application Number:	NA	
Filing Date	:NA	
(62) Divisional to Application Number	:NA	
Filing Date	:NA	

(57) Abstract :

The present invention, relates to ultrafast resistive type humidity sensor based on lanohybrids.' The process for making sensor, firstly prepared the silver nterdigilated electrodes (IDE) on pre-cleaned flexible tempered glass substrates)y using thermal evaporation in vacuum coating unit. The humidity sensor has the capability to record different breathing patterns as well as has the ability to detect >reathing at different rates.

No. of Pages : 26 No. of Claims : 3

(12) PATENT APPLICATION PUBLICATION

(21) Application No.202011010487 A

(19) INDIA

(22) Date of filing of Application :11/06/2020

(43) Publication Date : 11/06/2021

(54) Title of the invention : AN ANTICOUNTERFEIT ELEMENT FOR USE IN HIGH VALUE DOCUMENTS AND METHOD OF MANUFACTURING THEREOF

(51) International classification	:B42D0025290000, B42D0025387000, B42D0025355000, G07D0007120500, B42D0015000000	(71) Name of Applicant : 1)Raj Prehar Address of Applicant :House No 10 , Sector 10 , Chandigarh - 160011, UT. India Chandigarh India 2)Manu Prehar 3)Vijay Raja 4)Vikram Kapadia
(31) Priority Document No	:NA	(72) Name of Inventor : 1)Raj Prehar 2)Manu Prehar 3)Vijay Raja 4)Vikram Kapadia
(32) Priority Date	:NA	
(33) Name of priority country	:NA	
(86) International Application No	:NA	
Filing Date	:NA	
(87) International Publication No	: NA	
(61) Patent of Addition to Application Number	:NA	
Filing Date	:NA	
(62) Divisional to Application Number	:NA	
Filing Date	:NA	

(57) Abstract :

The present invention relates to an anticounterfeit element (100) for use in documents of value or high value documents along with device/equipment for detection of the same and a method of manufacturing the same The anticounterfeit element (100) comprising a substrate (102), a pigment material which exhibit a covert security feature and/or forensic features (104) disposed on the substrate (102), and further dispose of a forensic material with coating/ pigment material exhibit forensic security feature (106) as a unique spectral fingerprint over or aside of covert pigment material, which being detectable upon exciting with a radiation having a wavenumber in a predetermined range, the forensic security feature (106) is incorporated with the covert security feature (104). Further, an equipment (200) for determining genuineness of a document of value is disclosed. The anticounterfeit element (100) is reliable, and is identifiable using the equipment (200).

No. of Pages : 33 No. of Claims : 17

(54) Title of the invention : COMPRESSION WITH ANNEALING SYSTEM FOR PRINTED FILM CONDUCTIVITY ENHANCEMENT

(51) International classification	:H01B0001240000, H01B0001220000, H05K0001090000, G01N0027120000, G06T0007730000	(71) Name of Applicant : 1)Sandeep Kumar Address of Applicant :H. No. 1282/4, Rohtash Nagar, Rohtak (Haryana) Haryana India 2)Chandra Charu Tripathi
(31) Priority Document No	:NA	(72) Name of Inventor :
(32) Priority Date	:NA	1)Sandeep Kumar
(33) Name of priority country	:NA	2)Chandra Charu Tripathi
(86) International Application No	:NA	3)Kapil Bhatt
Filing Date	:NA	
(87) International Publication No	: NA	
(61) Patent of Addition to Application Number	:NA	
Filing Date	:NA	
(62) Divisional to Application Number	:NA	
Filing Date	:NA	

(57) Abstract :

Printed electronics is rising exponentially due to its additive manufacturing nature that saves a lot of functional material. However, the final properties of the printed film depend upon ink constituents, printing technique, thickness, and uniformity of the layer, and post-processing steps such as annealing, sintering, compression, etc. Uniformity of the layer contributes a lot to the electrical conductivity of the printed layer and post-processing plays an important role to achieve it. There are numerous reports on the impact of post-processing techniques on the electrical conductivity of the printed layers and there are various systems commercially available to perform these tasks. But, there is hardly any system that can perform multiple post-processing techniques simultaneously. In the present system, two post-processing techniques can be executed simultaneously i.e. compression and annealing. It consists of two rollers rotating at a similar speed and the crescent-shaped hot plate covering the rollers to anneal the layers during compression. It can be operated manually and with a motor. When the printed layer passes through the nip gap between the rollers it experiences the shear force and it gets compressed as well as became uniform. If during compression the temperature has been kept higher than the boiling temperature of the ink solvent, it helps in the rearrangement of the microstructure and conductivity of the printed layer get enhanced. The nip gap between the rollers can be adjusted to process different thickness of substrate and printing using gear and/or hydraulic. The speed of compression cum annealing can be varied by varying rotational speed of rollers manually and/or using electric motor. The system will be very much useful in both sheet-to-sheet as well as roll-to-roll processes.

No. of Pages : 8 No. of Claims : 10

(12) PATENT APPLICATION PUBLICATION

(21) Application No.202011017923 A

(19) INDIA

(22) Date of filing of Application :27/07/2020

(43) Publication Date : 11/06/2021

(54) Title of the invention : GRINDING MEDIA SEPARATION SYSTEM FOR INK AND OTHER FORMULATIONS PROCESSED THROUGH BEAD MILLING

(51) International classification	:A61K0038000000, B01D0061140000, B02C0017160000, F26B0003120000, C04B0035486000	(71) Name of Applicant : 1)Chandra Charu Tripathi Address of Applicant :University Institute of Engineering and Technology, Kurukshetra University Haryana India 2)Sandeep Kumar
(31) Priority Document No	:NA	(72) Name of Inventor :
(32) Priority Date	:NA	1)Chandra Charu Tripathi
(33) Name of priority country	:NA	2)Sandeep Kumar
(86) International Application No	:NA	3)Kapil Bhatt
Filing Date	:NA	
(87) International Publication No	: NA	
(61) Patent of Addition to Application Number	:NA	
Filing Date	:NA	
(62) Divisional to Application Number	:NA	
Filing Date	:NA	

(57) Abstract :

Grinding media is the basic entity of the bead mill as it transfers the force from the mill to the slurry/suspension to break down the particles. After achieving the desired fineness of the particles or product is ready, grinding media is needed to be separated from the product. There are various commercial bead mills of large capacity and have the provision of grinding media separation. But, there are numerous laboratory as well as small production mills that donTMt have any grinding media separation system. To separate the formulation from grinding media after processing from these systems manual and/or semimanual sieving has been used that results in material wastage as well as time-consuming. Whereas, in the proposed system, there is no material wastage and it will be a very fast process. The system consists of two drums; where the inner drum is perforated and rotates with the motor and the outer drum acts as a collector of the formulation. The mixer of grinding media and the final product is fed into the inner drum and it has been rotated at high speed. The product came out from the holes into the collector drum and the grinding media remains inside. There is a nozzle in the outer drum through which the product can be filled into containers. The rotational speed of the motor can be changed using motor controller. Therefore, the system will be quite efficient for use in the laboratory as well as on a commercial scale for a large portfolio of productsTMs viscosity.

No. of Pages : 7 No. of Claims : 11

(12) PATENT APPLICATION PUBLICATION

(21) Application No.202011018223 A

(19) INDIA

(22) Date of filing of Application :28/07/2020

(43) Publication Date : 11/06/2021

(54) Title of the invention : OPTICAL LIGHT ASSISTED MICRO GRIDLINE BED FOR MANUAL SCREEN PRINTING SYSTEM TO ACHIEVE BETTER REGISTRATION IN MULTILAYER PRINTING OF CIRCUITS AND DEVICES

(51) International classification	:G03F0009000000, B33Y0050020000, H05K0003040000, B41M0003000000, G06K0015100000	(71) Name of Applicant : 1)Sandeep Kumar Address of Applicant :H. No. 1282/4, Rohtash Nagar, Rohtak (Haryana) Haryana India 2)Chandra Charu Tripathi
(31) Priority Document No	:NA	(72) Name of Inventor :
(32) Priority Date	:NA	1)Sandeep Kumar
(33) Name of priority country	:NA	2)Kapil Bhatt
(86) International Application No	:NA	3)Chandra Charu Tripathi
Filing Date	:NA	
(87) International Publication No	: NA	
(61) Patent of Addition to Application Number:	NA	
Filing Date	:NA	
(62) Divisional to Application Number	:NA	
Filing Date	:NA	

(57) Abstract :

Registration is the major issue in the case of multilayer printing of functional circuits and devices. To overcome the registration issue, the alignment of successive masks in printing should be so perfect that upon printing both layers overlap, perfectly. In the case of an automatic roll-to-roll printing system, highly sophisticated mask alignment techniques such as image processing are being used to achieve layers™ registration. While in the case of a sheet to sheet printing it is impossible to achieve good registration which limits the fabrication of multilayer device prototype with precise geometry at laboratory scale. Here, we propose a screen printing system to achieve a high level of registration for multilayer pattern printing on transparent as well as opaque substrates. It consists of an optical light-assisted screen printing bed along with a micro-scale gridline for the perfect alignment of mask and successive printed line. The system can be utilized to print both graphics and electronic devices with very high registration. The range of registration can be a few microns depending upon the gridline resolution.

No. of Pages : 8 No. of Claims : 11

(12) PATENT APPLICATION PUBLICATION

(21) Application No.202011019838 A

(19) INDIA

(22) Date of filing of Application :11/05/2020

(43) Publication Date : 11/06/2021

(54) Title of the invention : RAPID MILK ADULTERATION TESTING KIT AND METHODS THEREOF

(51) International classification	:H01M0010440000, G11B0017049000, G03G0015080000, A24D0003060000, B65D0006220000	(71) Name of Applicant : 1)Rajasthan University of Veterinary & Animal Sciences Address of Applicant :Vijay Bhawan Palace Complex, Veterinary University Road, Near Deen Dayal Upadhyay Circle, Bikaner 334001, Rajasthan, India Rajasthan India
(31) Priority Document No	:NA	(72) Name of Inventor :
(32) Priority Date	:NA	1)SHARMA, Dr. Sanjita
(33) Name of priority country	:NA	
(86) International Application No	:NA	
Filing Date	:NA	
(87) International Publication No	: NA	
(61) Patent of Addition to Application Number	:NA	
Filing Date	:NA	
(62) Divisional to Application Number	:NA	
Filing Date	:NA	

(57) Abstract :

The present invention relates to a rapid milk-adulteration testing kit comprising of test solution(s) for detection of adulterant(s) in milk sample and method thereof. The kit provides test solutions for detection of even traces of detergent, soda, starch and urea. The test solution(s) of the kit has high shelf life of up to a period ranging from 21 months to 27.6 months and low limit of detection (LOD) ranging from =0.1% to =0.25%. The solution based kit employs test reagents in the test solution at high dilution. The kit is a cost effective and user friendly kit for qualitative detection of the presence of said at least one adulterant by definite visual colour change.

No. of Pages : 30 No. of Claims : 14

(12) PATENT APPLICATION PUBLICATION

(21) Application No.202011022187 A

(19) INDIA

(22) Date of filing of Application :27/05/2020

(43) Publication Date : 11/06/2021

(54) Title of the invention : A METHOD AND SYSTEM FOR MINIMIZING AND CONTROLLING THE CONCENTRATE IN A RO WATER PURIFICATION SYSTEM

(51) International classification :C02F0001440000,
C02F0001280000,
C02F0001000000,
C02F0001580000,
C02F0009000000

(31) Priority Document No :NA
(32) Priority Date :NA
(33) Name of priority country :NA
(86) International Application No :NA
Filing Date :NA
(87) International Publication No : NA
(61) Patent of Addition to Application Number :NA
Filing Date :NA
(62) Divisional to Application Number :NA
Filing Date :NA

(71)Name of Applicant :

1)Somany Home Innovation Limited

Address of Applicant :Plot No. 68, Near GSK - R&D, Echelon
Institutional area Sector -32 Gurgaon Haryana,122001 _ India
Haryana India

(72)Name of Inventor :

1)Avnish K Verma

2)Nikhil Maheshwari

(57) Abstract :

The present invention relates to a system and method for minimizing the concentrate in a RO water purification system leading to less or zero discharge. More particularly, the present invention relates to a water purifier employing multiple separation mechanism and controllers for monitoring the re-treatment and re-utilization of separated liquid thereby controlling the amount of concentrate.

No. of Pages : 11 No. of Claims : 5

(12) PATENT APPLICATION PUBLICATION

(21) Application No.202011032257 A

(19) INDIA

(22) Date of filing of Application :28/07/2020

(43) Publication Date : 11/06/2021

(54) Title of the invention : FACE MASK WITH NATURAL ANTI-MICROBIAL FINISH

(51) International classification	:A41D0013110000, A01N0059160000, A61K0008970000, A61Q0019000000, A62B0018080000	(71) Name of Applicant : 1)KEEO LIFE PVT. LTD. Address of Applicant :M-6 OFFICE, BALRAM HOUSE, KARAMPURA, DELHI, NORTH WEST, DELHI 110015, INDIA Delhi India
(31) Priority Document No	:NA	(72) Name of Inventor :
(32) Priority Date	:NA	1)AMIT JAIN
(33) Name of priority country	:NA	2)SAMYAK JAIN
(86) International Application No	:NA	
Filing Date	:NA	
(87) International Publication No	: NA	
(61) Patent of Addition to Application Number	:NA	
Filing Date	:NA	
(62) Divisional to Application Number	:NA	
Filing Date	:NA	

(57) Abstract :

The present disclosure relates to the field of face mask with a naturally occurring anti-microbial finish. Anti-microbial agent like curcumin and aloe vera are safe even if they are ingested in human body compared to commercially available chemicals. The Face mask is made of multilayer system with the outer layer (108) providing water repellent property, second layer (109) providing the particle filtration property, third layer (110) which is cotton rich, treated with natural anti-microbial agent, fourth layer (111) treated with additional anti-microbial or fragrance finish and an inner layer (112) providing moisturizing and soothing effect to skin, being treated with aloe vera.

No. of Pages : 13 No. of Claims : 8

(12) PATENT APPLICATION PUBLICATION

(21) Application No.202111017619 A

(19) INDIA

(22) Date of filing of Application :15/04/2021

(43) Publication Date : 11/06/2021

(54) Title of the invention : GRASPING DEVICE FOR A COOKWARE

(51) International classification	:A61F0002680000, H02G0003080000, H02G0003140000, A61B0017221000, B25B0005120000	(71) Name of Applicant : 1)Ajay Kumar Goyal Address of Applicant :7675 Singh Sabha Road Sai Apartment Flat No. 4 Shakti Nagar, Near Amba Cinema, Delhi-110007, India (IN) Delhi India
(31) Priority Document No	:NA	(72) Name of Inventor :
(32) Priority Date	:NA	1)Ajay Kumar Goyal
(33) Name of priority country	:NA	
(86) International Application No	:NA	
Filing Date	:NA	
(87) International Publication No	: NA	
(61) Patent of Addition to Application Number:	:NA	
Filing Date	:NA	
(62) Divisional to Application Number	:NA	
Filing Date	:NA	

(57) Abstract :

The present invention provides a grasping assembly (1000) for an article which involves screwless connection and locking between the components of the grasping assembly (1000). The grasping assembly (1000) comprises a holding member (200) and a connecting mechanism (400) having a locking unit (410) and a clamp (420). The clamp (420) is operationally coupled with the locking unit (410) such that a plurality of protruding elements (412) of the locking unit (410) penetrate through a plurality of openings (422) of the clamp (420). Further, the connecting mechanism (400) securely engages with the holding member (200) upon snap-fitting. A locking arrangement (2000) of an article and a method of engaging a plurality of grasping assemblies (1000) with an article are also disclosed.

No. of Pages : 33 No. of Claims : 12

(12) PATENT APPLICATION PUBLICATION

(21) Application No.202111018129 A

(19) INDIA

(22) Date of filing of Application :20/04/2021

(43) Publication Date : 11/06/2021

(54) Title of the invention : A PESTICIDE SPRAYING FLYING DEVICE FOR OPTIMIZING THE QUANTITY SPRAYED AND MAKING IT TIME EFFICIENT

(51) International classification	:A01M0007000000, G01R0031280000, B64D0001180000, A61K0009160000, C23C0004180000	(71) Name of Applicant : 1)INDIAN INSTITUTE OF INFORMATION TECHNOLOGY, ALLAHABAD Address of Applicant :IIT Rd, Near Boys Hostel, Devghat, Jhalwa, Prayagraj, Uttar Pradesh, India-211015 Uttar Pradesh India
(31) Priority Document No	:NA	(72) Name of Inventor :
(32) Priority Date	:NA	1)Paawan Kumar
(33) Name of priority country	:NA	2)Shefali Vinod Remteke
(86) International Application No	:NA	3)Dr. Suneel Yadav
Filing Date	:NA	4)Dr. Pritish Kumar
(87) International Publication No	: NA	
(61) Patent of Addition to Application Number	:NA	
Filing Date	:NA	
(62) Divisional to Application Number	:NA	
Filing Date	:NA	

(57) Abstract :

This invention describes a drone based farming device which uses fewer amounts of pesticides in comparison with the traditional manned method of spraying using knapsack sprayers. It ensures environmental protection and management into the farming sector so that soil degradation and water pollution can be avoided. It has a 6 propeller system with an atomized sprayer to spray only the require quantity of pesticide. The drone has two control modes including manual and autonomous and the spraying system operates using the position data from GPS system to automatically return to base position when the tank becomes empty for refill. This addresses critical need of safety of the farmers from the harmful effects of crop protection chemicals and thus the pesticide spraying drone for smart farming which is an automated solution can help improve farmer's health.

No. of Pages : 24 No. of Claims : 9

(12) PATENT APPLICATION PUBLICATION

(21) Application No.202111020342 A

(19) INDIA

(22) Date of filing of Application :04/05/2021

(43) Publication Date : 11/06/2021

(54) Title of the invention : A MOUTH OPENING DEVICE •

(51) International classification	:A61M0016000000, A61B0001240000, A61Q0011000000, A61D0015000000, A61C0017020000	(71) Name of Applicant : 1)INNOVATIVE CANCER CARE AND REHABILITATION PVT LTD. Address of Applicant :FF-02 Omaxe Green Valley Plaza, Sector 42, Faridabad-121003, Haryana, India. Haryana India
(31) Priority Document No	:NA	(72) Name of Inventor :
(32) Priority Date	:NA	1)Dr. Pawan Gupta
(33) Name of priority country	:NA	2)Mr. Rishabh Agrawal
(86) International Application No	:NA	3)Mrs. Shruti Agrawal
Filing Date	:NA	
(87) International Publication No	: NA	
(61) Patent of Addition to Application Number	:NA	
Filing Date	:NA	
(62) Divisional to Application Number	:NA	
Filing Date	:NA	

(57) Abstract :

The present invention relates to an auxiliary mouth opening device for oral care. Said device comprises: a lower Jaw plate (1), an upper Jaw Plate (2), a screw (3), a rivet (4), a measuring scale (5), an arrow (6). The device facilitates oral care in trismus patients. It effectively opens up the mouth and estimates the degree of mouth opening and does not cause injuries to the patients while in use.

No. of Pages : 16 No. of Claims : 3

(12) PATENT APPLICATION PUBLICATION

(21) Application No.202111020599 A

(19) INDIA

(22) Date of filing of Application :06/05/2021

(43) Publication Date : 11/06/2021

(54) Title of the invention : DEEP LEARNING PROCESS MODEL FOR EFFICIENT ASSESSMENT AND PREDICTION OF LEARNERS EMOTIONS IN COLLABORATIVE LEARNING ENVIRONMENT

(51) International classification	:G06N0003040000, G06N0003080000, G05B0013040000, G06K0009620000, G06N0020000000	(71)Name of Applicant : 1)Dr. Srikanta Kumar Mohapatra Address of Applicant :Associate Professor, Department of Computer Science & Engineering, Chitkara University Institute of Engineering and Technology, Chitkara University, Punjab, India- 140401 Punjab India 2)DR. Bidush Kumar Sahoo 3)Dr. Premananda Sahu 4)Mr. Santosh Kumar Sharma 5)Dr. Ankita 6)Dr. Sukant Kishoro Bisoy
(31) Priority Document No	:NA	(72)Name of Inventor : 1)Dr. Srikanta Kumar Mohapatra 2)DR. Bidush Kumar Sahoo 3)Dr. Premananda Sahu 4)Mr. Santosh Kumar Sharma 5)Dr. Ankita 6)Dr. Sukant Kishoro Bisoy
(32) Priority Date	:NA	
(33) Name of priority country	:NA	
(86) International Application No	:NA	
Filing Date	:NA	
(87) International Publication No	: NA	
(61) Patent of Addition to Application Number	:NA	
Filing Date	:NA	
(62) Divisional to Application Number	:NA	
Filing Date	:NA	

(57) Abstract :

Assessment of a learner's in an online mode using Visibility on Video model(VOV). Visibility on Video (VOV) model is a deep learning process model which predicts the learner's emotions and analyses them whether they are interested or not interested in a topic, or they want more explanation about it. Based on the analysis of the learners the teacher or a resource person can change their mode of teaching or teaching aids in a more interactive way. VOV model will predict their emotions using a laptop camera or mobile phone camera and aggregate the information about the learners to the resource person or a teacher about their opinion about the topic without saying anything by the learners. Based on the assessment send by the VOV model the teacher or resource person can change their mode of teaching into interactive one or explain the topic by means of animation or any other videos. VOV model predicts the emotions of the majority learner and suggests the resource person or teacher to change the mode of teaching.

No. of Pages : 9 No. of Claims : 5

(12) PATENT APPLICATION PUBLICATION

(21) Application No.202111021170 A

(19) INDIA

(22) Date of filing of Application :10/05/2021

(43) Publication Date : 11/06/2021

(54) Title of the invention : A PROCESS FOR PREPARING SACCHARIN MONOPHASIC LIQUID FORMULATION TO MITIGATE BEHAVIORAL ABNORMALITIES IN DIABETES

(51) International classification	:A61K0009000000, C07D0275060000, G16B0045000000, B01J0037080000, C07K0005080000	(71) Name of Applicant : 1)Dr. Manish Kumar Address of Applicant :H. No. 568, Shiv Partap Nagar, Ambala Cantt, Haryana 133001 India Haryana India 2)Dr. Sushma Gupta 3)Monica Chail
(31) Priority Document No	:NA	(72) Name of Inventor :
(32) Priority Date	:NA	1)Dr. Manish Kumar
(33) Name of priority country	:NA	2)Dr. Sushma Gupta
(86) International Application No	:NA	3)Monica Chail
Filing Date	:NA	
(87) International Publication No	: NA	
(61) Patent of Addition to Application Number	:NA	
Filing Date	:NA	
(62) Divisional to Application Number	:NA	
Filing Date	:NA	

(57) Abstract :

The present disclosure relates to a process for preparing saccharin monophasic liquid formulation to mitigate behavioral abnormalities in diabetes. The process facilitates in preparation of saccharin monophasic liquid formulation and elucidate the effects of SMLF exposures on behavioural anomalies in non-insulin dependent diabetes mellitus using mice. The process facilitates in evaluating withdrawal effects of SMLF in relation to psychiatric disorders in diabetes. The SMLF containing 10% w/v saccharin sodium is prepared using various excipients and for characterization colour, odour, taste and pH are checked. Streptozotocin is administered in mice on day 1 to induce type-2 diabetes and blood glucose level is determined on day 5. From day 6, the mice are exposed to a two-bottle water and saccharin monophasic oral liquid formulation choice paradigm and are subjected to TST, FST and EPM tests. Plasma 17-deoxycortisol and whole brain monoamine oxidase activity, reduced glutathione and malondialdehyde content are determined.

No. of Pages : 28 No. of Claims : 10

(12) PATENT APPLICATION PUBLICATION

(21) Application No.202111021664 A

(19) INDIA

(22) Date of filing of Application :13/05/2021

(43) Publication Date : 11/06/2021

(54) Title of the invention : AN APPARATUS FOR AUTOMATIC ACCIDENT DETECTION AND PROCEDURAL POST-ACCIDENTAL INCIDENT CONTROLLING METHOD THEREOF

(51) International classification	:G06F0001160000, G01S0017931000, H02H0003040000, G01S0007481000, H04W0004020000	(71)Name of Applicant : 1)Ms. Indu Address of Applicant :Research Scholar, School of Information and Communication Technology, Gautam Buddha University, Greater Noida -201310, Uttar Pradesh, India Uttar Pradesh India 2)Dr. Sandhya Tarar 3)Nishant Poras 4)Mayank Tyagi 5)Ms. Namisha Bhasin 6)Prof. (Dr.) Vipin Kumar Tyagi 7)Purnendu Shekhar Pandey 8)Dr. Mayank Singh
(31) Priority Document No	:NA	(72)Name of Inventor : 1)Ms. Indu 2)Dr. Sandhya Tarar 3)Nishant Poras 4)Mayank Tyagi 5)Ms. Namisha Bhasin 6)Prof. (Dr.) Vipin Kumar Tyagi 7)Purnendu Shekhar Pandey 8)Dr. Mayank Singh
(32) Priority Date	:NA	
(33) Name of priority country	:NA	
(86) International Application No	:NA	
Filing Date	:NA	
(87) International Publication No	: NA	
(61) Patent of Addition to Application Number:	NA	
Filing Date	:NA	
(62) Divisional to Application Number	:NA	
Filing Date	:NA	

(57) Abstract :

The present invention relates to the apparatus for automatic accident detection and procedural post-accidental incident controlling method thereof. The apparatus for automatic accident detection and procedural post-accidental incident control comprised of an input acquisition module, an output presenting module, a database module and a computer readable module. The input acquisition module operable to receive information indicative of current condition and cause of current condition in a preferred area which is further comprised of a polycarbonate enclosure inside of which a sound sensor, a LiDAR sensor and a battery unit are placed. The sound sensor further comprised of at least one microphone, an amplifier, a peak detector, at least one sound microcontroller and a first buffer and a first transceiver. The LiDAR sensor further comprised of at least one light transmitter, at least one light receiver, a light microcontroller, a second buffer and at least one second transceiver.

No. of Pages : 24 No. of Claims : 7

(54) Title of the invention : IOT BASED SMART HEALTHCARE SOLUTION FOR PREDICTING SEVERITY PROGNOSIS IN HEART PATIENTS USING MACHINE LEARNING.

<p>(51) International classification</p> <p>(31) Priority Document No</p> <p>(32) Priority Date</p> <p>(33) Name of priority country</p> <p>(86) International Application No Filing Date</p> <p>(87) International Publication No</p> <p>(61) Patent of Addition to Application Number Filing Date</p> <p>(62) Divisional to Application Number Filing Date</p>	<p>:A61B0005000000, G16H0010600000, G06N0020000000, G06N0003080000, G06N0003040000</p> <p>:NA</p> <p>:NA</p> <p>:NA</p> <p>:NA</p> <p>:NA</p> <p>: NA</p> <p>:NA</p> <p>:NA</p> <p>:NA</p> <p>:NA</p> <p>:NA</p>	<p>(71)Name of Applicant :</p> <p>1)Dr. Laxman Singh (Associate Professor) Address of Applicant :(Principal Investigator) This patent is part of Research project sanctioned by Dr. APJ Abdul Kalam (Govt.) University, Lucknow, U.P, India. under Visvesvaraya Research Promotion Scheme vide Letter No. Dr. APJAKTU/Dean-PGSR/VRP , Address 3: Village-Dakora, P.O-Marrolli, The-Hodal, Distt-Palwal, Haryana-121106, India, Email: laxman.mehlawat2@gmail.comS-2020/05751 Uttar Pradesh India</p> <p>2)Mr. Sover Singh Bisht (Assistant Professor)</p> <p>3)Dr. Mahipal Singh Choudhry (Professor)</p> <p>4)Dr. Altaf Alam (Research Fellow)</p> <p>5)Dr. Gayatri Sakya (Assistant Professor)</p> <p>6)Dr. Sapna Sinha (Associate Professor)</p> <p>7)Rajeev Kumar (Assistant Professor)</p> <p>(72)Name of Inventor :</p> <p>1)Dr. Laxman Singh (Associate Professor)</p> <p>2)Mr. Sover Singh Bisht (Assistant Professor)</p> <p>3)Dr. Mahipal Singh Choudhry (Professor)</p> <p>4)Dr. Altaf Alam (Research Fellow)</p> <p>5)Dr. Gayatri Sakya (Assistant Professor)</p> <p>6)Dr. Sapna Sinha (Associate Professor)</p> <p>7)Rajeev Kumar (Assistant Professor)</p>
--	--	--

(57) Abstract :

Our Invention IOT based Smart Healthcare Solution for Predicting Severity Prognosis in Heart Patients using Machine Learning is a heart disease is the leading cause of death worldwide and Predicting heart disease is a very complex task since it requires experience along with advanced and intelligent knowledge. The invention is a Internet of Things (IoT) technology has adopted in healthcare systems to collect sensor values for heart disease diagnosis and prediction and also a more researchers have focused on the diagnosis of heart disease yet the accuracy of the diagnosis results is low. The invented IoT framework is to evaluate heart disease +99% accurately using a machine learning programming-MLP and the smartwatch and heart monitor device that is attached to the patient monitors the blood pressure and electrocardiogram (ECG). The performance of the system is analyzed by comparing the MLP with existing deep learning neural networks and logistic regression and also the results demonstrate that the MLP based heart disease. The invented system undertakes training as well as testing and the data from the UCI machine learning repository, Framingham, and Public Health Dataset were utilized for training and evaluating the disease. The UCI repository has Cleveland, Hungary, Switzerland, and the VA-Long Beach databases and also selected the Cleveland database as it has +567 records which are most complete.

No. of Pages : 18 No. of Claims : 5

(12) PATENT APPLICATION PUBLICATION

(21) Application No.202111022492 A

(19) INDIA

(22) Date of filing of Application :20/05/2021

(43) Publication Date : 11/06/2021

(54) Title of the invention : LOW COST MANGALORE TILE MANUFACTURE USING WASTE PLASTIC AND CONCRETE.

(51) International classification	:B29B0017000000, B29K0105260000, B29L0031100000, E04F0015100000, B29B0017020000	(71)Name of Applicant : 1)Prof.(Dr.) Pawan Kumar Bharti (Vice-Chancellor) Address of Applicant :Shri Venkateshwara University, Gajraula (Uttar Pradesh) India -244236 E-Mail: padutt@gmail.com, akumarmuit@gmail.com Mobile No:- +918595067540, +918409588012 Uttar Pradesh India 2)Dr. Vaneet Kumar (Associate Professor) 3)Naveen Thakur (Professor) 4)Nikesh Thakur 5)Dr. Mohinder Pal Garg (Associate Professor) 6)Dr. Vineet Bajaj (Professor and Head) 7)Ajay Guleria (Research Scholar) 8)Dr Barjinder Kaur (Assistant Professor) 9)Dr. Dinesh Pathak (Associate Professor) 10)Dr. Saruchi (Associate Professor) 11)Diksha Bhatt (Research Scholar)
(31) Priority Document No	:NA	(72)Name of Inventor : 1)Prof.(Dr.) Pawan Kumar Bharti (Vice-Chancellor) 2)Dr. Vaneet Kumar (Associate Professor) 3)Naveen Thakur (Professor) 4)Nikesh Thakur 5)Dr. Mohinder Pal Garg (Associate Professor) 6)Dr. Vineet Bajaj (Professor and Head) 7)Ajay Guleria (Research Scholar) 8)Dr Barjinder Kaur (Assistant Professor) 9)Dr. Dinesh Pathak (Associate Professor) 10)Dr. Saruchi (Associate Professor) 11)Diksha Bhatt (Research Scholar)
(32) Priority Date	:NA	
(33) Name of priority country	:NA	
(86) International Application No	:NA	
Filing Date	:NA	
(87) International Publication No	: NA	
(61) Patent of Addition to Application	:NA	
Number	:NA	
Filing Date	:NA	
(62) Divisional to Application Number	:NA	
Filing Date	:NA	

(57) Abstract :

The invention is to solid waste is a major problem for India. It is important to take immediate action on how to the intelligent way of reducing plastic waste as a strategy in solid waste management, especially from inorganic materials since it is essential to the welfare of society and the environment. In India there are tons of plastics disposal around the Indian all state and until now has not yet optimized discover or recycle for engineering usage and the quantities of disposable plastics are growing day by day and it takes hundreds of years for plastics material to degrade. Our Invention Low-Cost Mangalore Tile Manufacture using Waste Plastic and Concrete is a manufacturing process and a related product constituted of a Mangalore tile in waste plastic material. following process: 1: crushing a thermoplastic material of recovery. 2: injecting quality plastic material into a mold with a primary punch. 3: The matrix integrated to enable the develop of the first layer of the tile between them, rotating the mold to reverse the reciprocal position of the matrix. 4: the primary punch, replacing the primary punch with a secondary punch to mark out, in its association with the matrix, between the first layer, supported by the matrix. 5 : The second layer of a plastic material arranged inside the Mangalore tile. Advanced Scientific research now has used the mapped recycling approach by producing useful substances from the recycled waste plastic as a second, third strategy to replace natural substance and the reuse of plastic wastes plays an important role in sustainable solid waste management to help save natural resources that are not replenished, it decreases the pollution of the environment and it also helps to save.

No. of Pages : 14 No. of Claims : 8

(12) PATENT APPLICATION PUBLICATION

(21) Application No.202111023026 A

(19) INDIA

(22) Date of filing of Application :24/05/2021

(43) Publication Date : 11/06/2021

(54) Title of the invention : SOLAR AIR HEATER FLAT PLATE ABSORBER INTEGRATED THERMO-ELECTRIC GENERATOR WITH LATENT HEAT STORAGE MATERIAL

(51) International classification	:F24F0005000000, F24S0010500000, F24S0010000000, H01L0035300000, F24S0080500000	(71) Name of Applicant : 1)Eswaramoorthy Muthusamy Address of Applicant :Professor School of Mechanical Engg Shri Mata vaishno Devi University Katra Jammu & Kashmir India
(31) Priority Document No	:NA	(72) Name of Inventor : 1)Eswaramoorthy Muthusamy
(32) Priority Date	:NA	
(33) Name of priority country	:NA	
(86) International Application No	:NA	
Filing Date	:NA	
(87) International Publication No	: NA	
(61) Patent of Addition to Application Number	:NA	
Filing Date	:NA	
(62) Divisional to Application Number	:NA	
Filing Date	:NA	

(57) Abstract :

The present invention provides an innovative design of solar air heater flat plate absorber having an integrated bismuth telluride based thermoelectric generator with latent heat storage materials in rectangular based metal container at longitudinal position. The generated electricity from thermoelectric generator helps to drives the blower to maintain the mass flow rate of air in air heating process using solar radiation. It comprises flat plate absorber, thermoelectric generator, latent heat storage materials, transparent glass sheet, and air inlet and outlet section. The present innovation offers an efficient and self-driven method for mass flow rate of air utilizing solar radiant energy by eliminating external supply of electricity to drive the blower. The positioning and integration of thermoelectric generator and latent heat storage materials an excellent thermal design. The present invention helps to an enhancement of heat transfer mechanism by increase in mass flow rate of air, higher value of heat transfer co-efficient and heat storage for additional time to the operation compared to conventional flat solar air heater.

No. of Pages : 2 No. of Claims : 5

(12) PATENT APPLICATION PUBLICATION

(21) Application No.202111023181 A

(19) INDIA

(22) Date of filing of Application :24/05/2021

(43) Publication Date : 11/06/2021

(54) Title of the invention : A SYSTEM AND METHOD FOR Demeanor BASED TRUST MEASUREMENT AND JOB PLACEMENT IN FOG COMPUTING MILIEU

(51) International classification	:G06F0009500000, H04L0029080000, G06Q0010100000, G06F0016245000, G06Q0010000000	(71) Name of Applicant : 1)Richa Verma Address of Applicant :Department of Computer Science, Babasaheb Bhimrao Ambedkar University, (A Central University), Raebareli Road, Lucknow, Uttar Pradesh India
(31) Priority Document No	:NA	2)Jasleen Kaur
(32) Priority Date	:NA	3)Dr. Shalini Chandra
(33) Name of priority country	:NA	(72) Name of Inventor :
(86) International Application No	:NA	1)Richa Verma
Filing Date	:NA	2)Jasleen Kaur
(87) International Publication No	: NA	3)Dr. Shalini Chandra
(61) Patent of Addition to Application Number	:NA	
Filing Date	:NA	
(62) Divisional to Application Number	:NA	
Filing Date	:NA	

(57) Abstract :

A system (100) for demeanour based trust measurement and job placement in fog computing milieu comprises one or more ground level devices (106) configured to submit corresponding job requests having respective resource requirements, one or more fog broker (102) configured to receive the one or more job request from the one or more ground level devices (106), contain the resource requirements in a matrix determining type and quantity of the resource requirements for each ground level device (106) and broadcast the job requests for with the resource requirements from the matrix, one or more fog nodes (104), having respective capacity plans, registered in the one or more fog broker (102). Each fog node (104) having a trust value. The one or more fog broker configured to place the job request with corresponding resource requirement to the fog node (104) with a highest trust value.

No. of Pages : 31 No. of Claims : 14

(54) Title of the invention : OXYGEN LEVEL ENHANCER IN AIR THROUGH ELECTROLYSIS OF WATER

<p>(51) International classification</p> <p>(31) Priority Document No</p> <p>(32) Priority Date</p> <p>(33) Name of priority country</p> <p>(86) International Application No Filing Date</p> <p>(87) International Publication No</p> <p>(61) Patent of Addition to Application Number Filing Date</p> <p>(62) Divisional to Application Number Filing Date</p>	<p>:C25B0001040000, C25B0015020000, C25B0009000000, C25B0001100000, C01B0013020000</p> <p>:NA</p> <p>:NA</p> <p>:NA</p> <p>:NA</p> <p>:NA</p> <p>:NA</p> <p>:NA</p> <p>:NA</p> <p>:NA</p> <p>:NA</p>	<p>(71)Name of Applicant :</p> <p>1)Pradeep Kumar Gupta Address of Applicant :2/695 Buddhi Vihar, Delhi Road Moradabad Uttar Pradesh India Uttar Pradesh India</p> <p>2)Anubhav Gupta</p> <p>3)Archana Ravindra Jain</p> <p>4)Ankit Kumar</p> <p>5)Arun Kumar Pipersenia</p> <p>6)Navneet Kumar Vishnoi</p> <p>7)Vineet Saxena</p> <p>8)Jyoti Ranjan Labh</p> <p>9)Sandeep Saxena</p> <p>(72)Name of Inventor :</p> <p>1)Pradeep Kumar Gupta</p> <p>2)Anubhav Gupta</p> <p>3)Archana Ravindra Jain</p> <p>4)Ankit Kumar</p> <p>5)Arun Kumar Pipersenia</p> <p>6)Navneet Kumar Vishnoi</p> <p>7)Vineet Saxena</p> <p>8)Jyoti Ranjan Labh</p> <p>9)Sandeep Saxena</p>
--	--	---

(57) Abstract :

An apparatus (100) for generating pure oxygen through electrolysis of water, comprises a main housing (102), a water inlet (108) adapted for supply of fresh charge of water into the main housing (102), a water reservoir (220) adapted to store water within the main housing (102), a main oxygen outlet (112) adapted to supply generated pure oxygen out from the main housing (102), a plurality of oxygen generating cells (210) provided within the main housing (102), a power source (230) configured to supply electrical power to the plurality of oxygen generating cells (210). Each oxygen generating cell of the plurality of oxygen generating cells (210) includes an anode (211) adapted to supply generated pure oxygen, a cathode (213) adapted to exhaust generated hydrogen, and an electrolyte solution (215) including water as a solvent. The anode (211) and the cathode (213) have been partially submerged in the electrolyte solution (215).

No. of Pages : 22 No. of Claims : 10

(12) PATENT APPLICATION PUBLICATION

(21) Application No.202111023392 A

(19) INDIA

(22) Date of filing of Application :26/05/2021

(43) Publication Date : 11/06/2021

(54) Title of the invention : AN ARTIFICIAL INTELLIGENCE (AI) BASED SYSTEM FOR USER CLASSIFICATION AND IDENTIFICATION FOR PROVIDING REWARDS TO USER AND METHOD THEREOF

(51) International classification	:G06Q0030020000, G06N0020000000, G06N0003080000, G06N0007000000, G06N0005020000	(71)Name of Applicant : 1)Deepak Dudeja Address of Applicant :Research Scholar Computer Science & Applications Department Ct University, Ludhiana, Punjab Ferozepur Rd, Sidhwan Khurd, Punjab 142024 Punjab India 2)Sarvesh Kumar 3)Medhavi Malik 4)Ms. Suchita Arora 5)Rashi Saxena 6)Dilip Kumar Saini 7)Dr. Awanish Kumar Singh 8)Neetesh Soni
(31) Priority Document No	:NA	(72)Name of Inventor : 1)Deepak Dudeja 2)Sarvesh Kumar 3)Medhavi Malik 4)Ms. Suchita Arora 5)Rashi Saxena 6)Dilip Kumar Saini 7)Dr. Awanish Kumar Singh 8)Neetesh Soni
(32) Priority Date	:NA	
(33) Name of priority country	:NA	
(86) International Application No	:NA	
Filing Date	:NA	
(87) International Publication No	: NA	
(61) Patent of Addition to Application Number	:NA	
Filing Date	:NA	
(62) Divisional to Application Number	:NA	
Filing Date	:NA	

(57) Abstract :

The present invention discloses an Artificial Intelligence (AI) based system for user classification and identification for providing rewards to a user and method thereof. The system includes, but not limited to, a processing unit provided in a cloud network for analysing previously offered rewards with an account and its transaction history with respect to a predefined business entity; an Artificial Intelligence and Machine learning module to create a metrics of the previously offered rewards and classifying the user with respect to their dealt business entity. The Artificial Intelligence and Machine learning module is configured to generate a new reward and offers for presenting to the user or holder of the account by identifying them on getting eligible after a predefined set of transactions.

No. of Pages : 21 No. of Claims : 8

(12) PATENT APPLICATION PUBLICATION

(21) Application No.202111023393 A

(19) INDIA

(22) Date of filing of Application :26/05/2021

(43) Publication Date : 11/06/2021

(54) Title of the invention : AN APPARATUS FOR PERFORMING CHEMICAL REACTION OF DETECTING ARSENIC

(51) International classification	:C02F0001520000, B01L0003000000, H01M0004360000, C04B0035520000, H05H0001460000	(71) Name of Applicant : 1)DR. PRAVEEN KUMAR Address of Applicant :Quantum School of Health Sciences, Quantum University, Mandawar- 22 Km milestone, Roorkee - Dehradun Highway, Roorkee-247167, Uttarakhand, India Uttarakhand India
(31) Priority Document No	:NA	2)DR. MEENU CHAUDHARY
(32) Priority Date	:NA	3)DR. ASHUTOSH BADOLA
(33) Name of priority country	:NA	4)DR. BHUPENDRA SINGH
(86) International Application No	:NA	(72) Name of Inventor :
Filing Date	:NA	1)DR. PRAVEEN KUMAR
(87) International Publication No	: NA	
(61) Patent of Addition to Application	:NA	
Number	:NA	
Filing Date	:NA	
(62) Divisional to Application Number	:NA	
Filing Date	:NA	

(57) Abstract :

The present invention relates to an apparatus (100) for performing chemical reaction of detecting arsenic gaseous compound: a platform stand (101); a reaction container (102), wherein said reaction container (102) comprises a reagent inlet (105) and a transfer outlet (106); a product retainer container (103), said product retainer container (103) comprises a transfer inlet (107) and a product outlet (108); a curve glass pipe (104), wherein said curve glass pipe (104) connects said reaction container (102) and said product retainer container (103); a plurality of corks (110); and wherein said platform stand (101) is having arrangement to place said reaction container (102) and said product retainer container (103); wherein said curve glass pipe (104) comprises a hollow shape end (109A) and a flat open end (109B); wherein said reaction container (102) and said product retainer container (103) contains a plurality of reagents.

No. of Pages : 18 No. of Claims : 8

(12) PATENT APPLICATION PUBLICATION

(21) Application No.202111023402 A

(19) INDIA

(22) Date of filing of Application :26/05/2021

(43) Publication Date : 11/06/2021

(54) Title of the invention : ELECTRICITY GENERATING DEVICE

(51) International classification	:H04M0001725000, H04R0001020000, H02N0002180000, H04R0007040000, H02K0021160000	(71)Name of Applicant : 1)GRAPHIC ERA (DEEMED TO BE) UNIVERSITY Address of Applicant :566/6, Bell Road, Clement Town, Dehradun 248002, Uttarakhand, India Uttarakhand India 2)GRAPHIC ERA HILL UNIVERSITY, DEHRADUN CAMPUS
(31) Priority Document No	:NA	(72)Name of Inventor :
(32) Priority Date	:NA	1)Deepak Singh Rana
(33) Name of priority country	:NA	2)Sumeshwar Singh
(86) International Application No	:NA	3)Shiv Ashish Dhondiyal
Filing Date	:NA	4)Dr. Varij Panwar
(87) International Publication No	: NA	5)Ms. Palak Aggarwal
(61) Patent of Addition to Application Number	:NA	
Filing Date	:NA	
(62) Divisional to Application Number	:NA	
Filing Date	:NA	

(57) Abstract :

The invention discloses an electricity generating device 101 for generating electricity using sound energy of the environment, said device 101 comprising: a fan motor 201; a magnetic bar 202; a sound vibration source 102; a plurality of magnetic coil 203; a voltmeter 204; a battery; a memory; and a processor. The method of generating electricity using sound energy of the environment comprises: receiving vibration of sound from said sound vibration source 102 to generate magnetic flux between two poles of said magnetic bar 202; rotating said fan motor 201 fitted between said magnetic bar 202 due to vibration of sound received from said sound vibration source 102 for changing magnetic flux; generating electricity in said plurality of magnetic coil 203 due to change in magnetic flux by rotating said fan motor 201; and storing, by said electricity generating device 101, said electricity in said battery for further use.

No. of Pages : 21 No. of Claims : 7

(54) Title of the invention : SYNTHESIS AND PHARMACOLOGICAL EVALUATION OF IBUPROFEN ENTRAPPED SILVER NANOPARTICLES USING HERBALS

<p>(51) International classification :B82Y0030000000, B82Y0040000000, B22F0001000000, A01N0059160000, A61K0031192000</p> <p>(31) Priority Document No :NA (32) Priority Date :NA (33) Name of priority country :NA (86) International Application No :NA Filing Date :NA (87) International Publication No : NA (61) Patent of Addition to Application Number :NA Filing Date :NA (62) Divisional to Application Number :NA Filing Date :NA</p>	<p>(71)Name of Applicant :</p> <p>1)Dr. Mohit Address of Applicant :Associate Professor,Shri Ram Murti Smarak College of Engineering & Technology, Bareilly (Pharmacy),Ram Murti Puram, Bhojipura, 13 K.M., Bareilly-Nainital Highway, Bareilly, U.P., India, Pin Code-243202 Uttar Pradesh India</p> <p>2)Dr. Lalit Singh 3)Dr. Girendra Kumar Gautam 4)Dr. Manmohan Singhal 5)Dr. Amit Kumar Verma 6)Dr. Ajeet Singh 7)Dr. Piush Sharma 8)Dr. Parveen Kumar 9)Dr. Ganesh N. Sharma 10)Dr. Ritesh Jain 11)Dr. Vipin Kumar 12)Dr. Anirudha Rishi 13)Dr. Deenanath Jhade 14)Mr. Gulshan Rathore</p> <p>(72)Name of Inventor :</p> <p>1)Dr. Mohit 2)Dr. Lalit Singh 3)Dr. Girendra Kumar Gautam 4)Dr. Manmohan Singhal 5)Dr. Amit Kumar Verma 6)Dr. Ajeet Singh 7)Dr. Piush Sharma 8)Dr. Parveen Kumar 9)Dr. Ganesh N. Sharma 10)Dr. Ritesh Jain 11)Dr. Vipin Kumar 12)Dr. Anirudha Rishi 13)Dr. Deenanath Jhade 14)Mr. Gulshan Rathore</p>
---	---

(57) Abstract :

The present invention relates to synthesis of ibuprofen loaded silver nanoparticles by using herbal extract. The method used for the synthesis of silver Nano particles by green synthesis and to formulate a cost-effective antibacterial dosage form. The prepared ibuprofen loaded silver nanoparticles by using fruit extracts were effective against the gram negative bacteria E.coli.

No. of Pages : 16 No. of Claims : 1

(12) PATENT APPLICATION PUBLICATION

(21) Application No.202111023457 A

(19) INDIA

(22) Date of filing of Application :26/05/2021

(43) Publication Date : 11/06/2021

(54) Title of the invention : ZIRCONIUM AND URANIUM METAL COMPLEXES OF SEMICARBAZIDE DERIVATIVES WITH ANTIBACTERIAL ACTIVITY

(51) International classification	:A61K0035742000, C12N0015750000, C07D0471040000, A61K0038000000, A61P0031040000	(71) Name of Applicant : 1)Dr. CHANDRA MOHAN Address of Applicant :SBAS, K R MANGALAM UNIVERSITY, SOHNA ROAD,HARYANA, GURUGRAM- 122103, Haryana India
(31) Priority Document No	:NA	2)Mr. VINOD KUMAR
(32) Priority Date	:NA	3)Dr. SARLA KUMARI
(33) Name of priority country	:NA	4)Dr. NEERAJ KUMARI
(86) International Application No	:NA	(72) Name of Inventor :
Filing Date	:NA	1)Dr. CHANDRA MOHAN
(87) International Publication No	: NA	2)Mr. VINOD KUMAR
(61) Patent of Addition to Application Number	:NA	3)Dr. SARLA KUMARI
Filing Date	:NA	4)Dr. NEERAJ KUMARI
(62) Divisional to Application Number	:NA	
Filing Date	:NA	

(57) Abstract :

The present invention relates to synthesis and characterization of Schiff base ligand (L) by reacting semicarbazide with 2-acetylthiophene in ethanol solvent and its metal complexes have also been synthesized by using Zr⁴⁺, Pb²⁺ and U⁶⁺ ions. Schiff bases of semicarbazide are often having promising biological activities like anti-inflammatory, antidepressant, antiglycation, antibacterial etc. Schiff base ligand and metal complexes were characterized and have shown appropriate results when analyzed on UV-Vis., NMR, FT-IR and antibacterial activities. They were tested against gram-negative [E. Coli. (MTCC No: 452)] and gram-positive [Bacillus sp (MTCC No: 297)] bacterial strains by using Kirby-Bauer™s method. Schiff base complexes of Zirconium [Zr(L)₄]Cl₂] and lead [Pb(L)₂]Cl₂] were found to be more active against both bacterial strains having zone of inhibition 11.14 ± 0.2 & 10.23 ± 0.5 mm and 12.02 ± 0.3 & 11.05 ± 0.3 mm on E. Coli. and on Bacillus species respectively.

No. of Pages : 13 No. of Claims : 1

(12) PATENT APPLICATION PUBLICATION

(21) Application No.202111023516 A

(19) INDIA

(22) Date of filing of Application :26/05/2021

(43) Publication Date : 11/06/2021

(54) Title of the invention : A PORTABLE AMBU BAG VENTILATOR SYSTEM •

(51) International classification :A61M0016000000,
A61M0016100000,
G01L0011000000,
F02D0041000000,
A61M0016200000

(31) Priority Document No :NA
(32) Priority Date :NA
(33) Name of priority country :NA
(86) International Application No :NA
Filing Date :NA
(87) International Publication No : NA
(61) Patent of Addition to Application Number :NA
Filing Date :NA
(62) Divisional to Application Number :NA
Filing Date :NA

(71)**Name of Applicant :**
1)GLA University, Mathura
Address of Applicant :GLA University, 17km Stone, NH-2,
Mathura-Delhi Road, CHAUMUHAN MATHURA UTTAR
PRADESH India 281406 Uttar Pradesh India

(72)**Name of Inventor :**
1)Prof. Kamal Sharma
2)Mr. Himanshu Senger
3)Mr. Vineet Sinha
4)Mr. Abhinav Mishra
5)Mr. Shailesh Sharma
6)Prof. Diwakar Bhardwaj

(57) Abstract :

The present invention provides a low cost, portable ventilator system based on Ambu bag, comprising; a feedback controlled squeezing unit (FCSU) (1)for the intake of combination of oxygen and air; a one-directional valve (2)connected at both ends of a two-way tube to control the flow direction; a two-way tube (3)for intake of oxygen and exhale of carbon dioxide; a sensing device (4) adapted to measure the Peak Inspiratory Pressure (PIP) and PEEP pressures and provide pressure values to a controller; a controller(5) to control the amount of squeezing required depending upon the pressure values and opening and closing of one directional valve; a filter(6); and a power supply unit (7) connected to the controller. besides the present invention is cost effective, reliable and potable.

No. of Pages : 22 No. of Claims : 10

(12) PATENT APPLICATION PUBLICATION

(21) Application No.202111023672 A

(19) INDIA

(22) Date of filing of Application :27/05/2021

(43) Publication Date : 11/06/2021

(54) Title of the invention : A SYSTEM FOR BATTERY OPTIMIZATION FOR AUTOMATIC VEHICLE AND METHOD THEREOF

(51) International classification	:G06N0003080000, G06N0003040000, G06K0009000000, G06K0009460000, G01R0031367000	(71) Name of Applicant : 1)Anshuka Bansal Address of Applicant :Associate Professor Electrical & Instrumentation Engineering (EIE), SLIET Longowal, Punjab Punjab India
(31) Priority Document No	:NA	2)Dr. Priti Prabhakar
(32) Priority Date	:NA	3)Sunil Kumar Bansal
(33) Name of priority country	:NA	(72) Name of Inventor :
(86) International Application No	:NA	1)Anshuka Bansal
Filing Date	:NA	2)Dr. Priti Prabhakar
(87) International Publication No	: NA	3)Sunil Kumar Bansal
(61) Patent of Addition to Application Number	:NA	
Filing Date	:NA	
(62) Divisional to Application Number	:NA	
Filing Date	:NA	

(57) Abstract :

The present invention discloses a system for battery optimization for automatic vehicle. The system is configured with Data-driven modeling using different battery signals to provide robust battery capacity estimation using data based decision. The proposed method and system further, a data acquisition unit, which consists of the sensors capture the desired data from battery and convert it in the desired format and presented to a data processing unit. Further, the data processing unit is taking this data and preprocesses it. Further, wherein the instructions to the data processing unit is further comprising a deep neural network and implementing equipment.

No. of Pages : 17 No. of Claims : 6

(12) PATENT APPLICATION PUBLICATION

(21) Application No.202111023776 A

(19) INDIA

(22) Date of filing of Application :28/05/2021

(43) Publication Date : 11/06/2021

(54) Title of the invention : INVERTED VERTICAL E PLATE BANK PROTECTION SYSTEM FOR RIVER

(51) International classification	:E02B0003120000, E02B0003060000, C02F0001440000, G01C0013000000, G01F0023296000	(71) Name of Applicant : 1)Vikas Garg Address of Applicant :Associate Professor, Department of Civil Engineering, Central University of Haryana, Mahendergarh Haryana India
(31) Priority Document No	:NA	(72) Name of Inventor :
(32) Priority Date	:NA	1)Dr Vikas Garg
(33) Name of priority country	:NA	2)Dr Ajay Kumar Bansal
(86) International Application No	:NA	3)Dr Baldev Setia
Filing Date	:NA	4)Dr. D V S Verma
(87) International Publication No	: NA	5)Yempali Priyanka
(61) Patent of Addition to Application Number:	:NA	6)Muskan Garg
Filing Date	:NA	
(62) Divisional to Application Number	:NA	
Filing Date	:NA	

(57) Abstract :

Inverted vertical E plate bank protection system for river to improvise safety of river bank protection, comprises of three horizontal plates which are to be attached at the top edge of vertical plate, at the centre of vertical plate(at bed level) and at bottom of the vertical plate, three horizontal plates protect vertical plate from the direct impact of erosive action of water vertical plate is positioned at the bed level about 0.4 times of depth of water, three size of these horizontal plates were tested 0.05h, 0.1h and 0.5h reduces scour nearly 60-70% around the vertical plate(vane).

No. of Pages : 18 No. of Claims : 5

(12) PATENT APPLICATION PUBLICATION

(21) Application No.202111023892 A

(19) INDIA

(22) Date of filing of Application :28/05/2021

(43) Publication Date : 11/06/2021

(54) Title of the invention : EXPONENTIAL CALCULATOR USING PARALLEL PROCESSOR SYSTEMS

(51) International classification	:H04L0012240000, G06F0009500000, G06F0015800000, G06F0011220000, G06F0015020000	(71) Name of Applicant : 1)LAKHOTIA, Bhavesh Address of Applicant :274, Sector 6, Malviya Nagar, Jaipur 302017, India Rajasthan India
(31) Priority Document No	:NA	(72) Name of Inventor :
(32) Priority Date	:NA	1)LAKHOTIA, Bhavesh
(33) Name of priority country	:NA	
(86) International Application No	:NA	
Filing Date	:NA	
(87) International Publication No	: NA	
(61) Patent of Addition to Application Number	:NA	
Filing Date	:NA	
(62) Divisional to Application Number	:NA	
Filing Date	:NA	

(57) Abstract :

An exponential calculator based on parallel computing is disclosed. The exponential calculator (200) includes a master system (101) and a plurality of nodes interconnected with each other to transfer and receive information and perform sub-computations independently and simultaneously. The master system (101) is configured to select a number of nodes from the plurality of nodes required to perform sub-computations for calculation of an integer exponent. The selected nodes is configured to receive value of a node base and a node exponent from the master system (101). The selected nodes calculate a first computation value, a second computation value and a third computation value. The master system (101) is further configured to instruct a sub-set of the selected nodes to perform summation of a final sub-computation of the selected nodes and provide an output.

No. of Pages : 32 No. of Claims : 24

(12) PATENT APPLICATION PUBLICATION

(21) Application No.202111023942 A

(19) INDIA

(22) Date of filing of Application :28/05/2021

(43) Publication Date : 11/06/2021

(54) Title of the invention : IRON PHTHALOCYANINE SUPRAMOLECULAR ARCHITECTURE •

(51) International classification	:B82Y0030000000, C09K0011650000, B82Y0040000000, C08G0083000000, C01B0021060000	(71) Name of Applicant : 1)GLA University, Mathura Address of Applicant :GLA University,17km Stone, NH-2, Mathura-Delhi Road, CHAUMUHAN MATHURA (U.P) - 281406 Uttar Pradesh India
(31) Priority Document No	:NA	(72) Name of Inventor :
(32) Priority Date	:NA	1)Mr. Anuj Kumar
(33) Name of priority country	:NA	2)Mr. Vinod Kumar Vashistha
(86) International Application No	:NA	3)Mr. Dipak Kumar Das
Filing Date	:NA	
(87) International Publication No	: NA	
(61) Patent of Addition to Application Number	:NA	
Filing Date	:NA	
(62) Divisional to Application Number	:NA	
Filing Date	:NA	

(57) Abstract :

Iron Phthalocyanine Supramolecular Architecture • The present invention discloses a self-assembled FePc nanorods like supramolecular architecture, wherein the molecular-molecular assembly is organized in the fashion of -phase FePc arrangements with a suitable distance between two FePc crystals. The present invention also discloses a method for preparation of self-assembled FePc nanorods like supramolecular architecture, which is characterized in that adopting following steps: dispersing 0.05 g FePc in 10 mL ethylene glycol; providing ultrasonic treatment for 30 min; transferring the slurry into microwave autoclave irradiated at 350W, with varying the heating rate at 120 °C, 150 °C and 180 °C for 5 min; centrifuging the slurry to collect the dark blue precipitate at 5000 rpm; washing the dark blue precipitate successively with methanol and ethanol several times; and drying at 60 °C under vacuum condition for 12 h o obtain FePc nanorods in solid powder form.

No. of Pages : 21 No. of Claims : 8

(12) PATENT APPLICATION PUBLICATION

(21) Application No.202111023970 A

(19) INDIA

(22) Date of filing of Application :29/05/2021

(43) Publication Date : 11/06/2021

(54) Title of the invention : A METHOD FOR TECHNOLOGY INTELLIGENCE QUOTIENT (TIQ)

(51) International classification	:G06Q0010060000, G06Q0030020000, A61K0036110000, G01N0033500000, A61B0005083000	(71) Name of Applicant : 1)Sharda University Address of Applicant :Plot No. 32, 34, Knowledge Park III, Greater Noida, Uttar Pradesh Uttar Pradesh India
(31) Priority Document No	:NA	(72) Name of Inventor :
(32) Priority Date	:NA	1)Dr. Subir Ranjan Das
(33) Name of priority country	:NA	
(86) International Application No	:NA	
Filing Date	:NA	
(87) International Publication No	: NA	
(61) Patent of Addition to Application Number	:NA	
Filing Date	:NA	
(62) Divisional to Application Number	:NA	
Filing Date	:NA	

(57) Abstract :

In the present disclosure a conceptual model has been developed for evaluating Technology Intelligence Quotient (ITQ) of any organisation. Technology Intelligence Quotient is the quotient which serves as the indicator which signifies the competence of an organisation to understand the technological capability of competitors and use information to achieve market leadership using research and development. Further the TIQ enables an organisation to effectively deploy and execute Competitive Technical Intelligence. Thereby, a company can focus onto identifying technological trends, opportunities and threats, and their relationship to competitors™ business strategies.

No. of Pages : 16 No. of Claims : 7

(12) PATENT APPLICATION PUBLICATION

(21) Application No.202111023974 A

(19) INDIA

(22) Date of filing of Application :29/05/2021

(43) Publication Date : 11/06/2021

(54) Title of the invention : SYSTEM AND METHOD FOR PROVIDING LOCATION-BASED SERVICES USING LOCATION ANALYTICS OF USER DEVICES WITH RESPECT TO TIME

(51) International classification	:H04L0029080000, G06Q0030020000, H04W0004029000, G10L0015220000, H04W0004020000	(71) Name of Applicant : 1)Dr. Deepak Dahiya Address of Applicant :College of Computer and Information Sciences, Majmaah University, Majmaah 11952, Saudi Arabia Saudi Arabia
(31) Priority Document No	:NA	2)Dr. Mamta Dahiya
(32) Priority Date	:NA	(72) Name of Inventor :
(33) Name of priority country	:NA	1)Dr. Deepak Dahiya
(86) International Application No	:NA	2)Dr. Mamta Dahiya
Filing Date	:NA	
(87) International Publication No	: NA	
(61) Patent of Addition to Application Number	:NA	
Filing Date	:NA	
(62) Divisional to Application Number	:NA	
Filing Date	:NA	

(57) Abstract :

A method (200) for providing location-based services using location analytics of user devices with respect to time comprising registering (202) a plurality of first user devices (102) associated with respective customers, and a plurality of second user devices (106) associated with respective service providers; generating (204) (206) respective customer profiles and respective service provider profiles; receiving (208) a plurality of locations of all the plurality of registered first user devices (102) on multiple time instances; clustering (210) and forming one or more customer zones at multiple locations; identifying (212) one or more service providers offering the preferred services in the one or more customer zones; providing (214) a list of available services providers offering services preferred by the each customer in the respective customer zone on the respective registered first user device (102); and providing (216) locations of the one or more customer zones to the plurality of registered service providers.

No. of Pages : 28 No. of Claims : 10

(12) PATENT APPLICATION PUBLICATION

(21) Application No.202111024111 A

(19) INDIA

(22) Date of filing of Application :31/05/2021

(43) Publication Date : 11/06/2021

(54) Title of the invention : FRACTURE REDUCTION AND PLATE STABILIZATION SYSTEM

(51) International classification	:A61B0017880000, A61B0017800000, A61B0017700000, A61B0017280000, A61G0013120000	(71) Name of Applicant : 1)Vineet Kumar Address of Applicant :Department of Orthopaedics, Dr RMLIMS, Gomti Nagar, Lucknow, Uttar Pradesh, India-226010 Uttar Pradesh India
(31) Priority Document No	:NA	2)Swagat Mahapatra
(32) Priority Date	:NA	3)Suruchi
(33) Name of priority country	:NA	(72) Name of Inventor :
(86) International Application No	:NA	1)Vineet Kumar
Filing Date	:NA	2)Swagat Mahapatra
(87) International Publication No	: NA	3)Suruchi
(61) Patent of Addition to Application Number	:NA	
Filing Date	:NA	
(62) Divisional to Application Number	:NA	
Filing Date	:NA	

(57) Abstract :

A fracture reduction and plate stabilization system to perform extramedullary fracture fixation for long bone fractures. This system consists of at least one pronged bone and plate holding and stabilizing forceps (Fig. 2) and the jaws on either side of the prong are combination jaw; with variable length. This forceps has at least one serrated jaw with flat and curved tip and other at least one pointed jaw with ball and spike. This fracture reduction and plate stabilization system is compatible with conventional Orthopaedic instruments for performing fracture fixation procedures in which extramedullary fixation. This system also contains a bone plate with multiple indentations on the outer surface between the screw holes. These indentations are meant for engaging the ball spike of the bone and plate reduction forceps. The indentations are positioned in such a way so as to coincide with the spikes of the double pronged bone and plate reduction and stabilizing forceps.

No. of Pages : 25 No. of Claims : 20

(54) Title of the invention : A ROOF DRAIN STRAINER SYSTEM

<p>(51) International classification</p> <p>(31) Priority Document No</p> <p>(32) Priority Date</p> <p>(33) Name of priority country</p> <p>(86) International Application No Filing Date</p> <p>(87) International Publication No</p> <p>(61) Patent of Addition to Application Number Filing Date</p> <p>(62) Divisional to Application Number Filing Date</p>	<p>:E04D0013040000, F16L0055240000, E04D0013080000, E03C0001264000, E03C0001262000</p> <p>:NA</p> <p>:NA</p> <p>:NA</p> <p>:NA</p> <p>:NA</p> <p>: NA</p> <p>:NA</p> <p>:NA</p> <p>:NA</p> <p>:NA</p> <p>:NA</p>	<p>(71)Name of Applicant :</p> <p>1)Dr. VASUDHA ARORA Address of Applicant :(ASSOCIATE PROFESSOR) ITS ENGINEERING COLLEGE, GREATER NOIDA, UP 201308, INDIA Uttar Pradesh India</p> <p>2)Dr. NIHAR RANJAN ROY</p> <p>3)Dr. RASHMI PRIYA</p> <p>4)YOGESH KUMAR</p> <p>5)SAKSHI SHARMA</p> <p>6)SAURABH KUMAR SINGH</p> <p>7)KAMAL KUMAR RANGA</p> <p>8)GOURAV KUMAR</p> <p>(72)Name of Inventor :</p> <p>1)Dr. VASUDHA ARORA</p> <p>2)Dr. NIHAR RANJAN ROY</p> <p>3)Dr. RASHMI PRIYA</p> <p>4)YOGESH KUMAR</p> <p>5)SAKSHI SHARMA</p> <p>6)SAURABH KUMAR SINGH</p> <p>7)KAMAL KUMAR RANGA</p> <p>8)GOURAV KUMAR</p> <p>9)HARDEEP</p>
--	--	---

(57) Abstract :

A roof drain strainer system (1) having upper (2) and lower strainer (3) which are connected and inserted inside the drain pipe (8). The pipe (8) is connected to the strainer system's lower portion and having two internal sides. The upper strainer (2) is connected to the left half side of the strainer system (1) and pipe (8). The lower strainer is connected to another half side or right side of the strainer system (1) and pipe (8). The strainer system (1) is being implanted into main/external pipe (11). There is a coupling (14) is between strainer system and pipe (8).

No. of Pages : 18 No. of Claims : 10

(12) PATENT APPLICATION PUBLICATION

(21) Application No.202111024129 A

(19) INDIA

(22) Date of filing of Application :31/05/2021

(43) Publication Date : 11/06/2021

(54) Title of the invention : INTERNET OF THINGS BASED USER CONTROLLED SOLAR ENERGY POWERED SMART IRRIGATION SYSTEM FOR PRECISION AGRICULTURE

(51) International classification	:A01G0025160000, H04W0084180000, A01B0079000000, G06N0020000000, G06N0003080000	(71)Name of Applicant : 1)Dr. Ranjana Address of Applicant :Associate Professor, Genetics and Plant Breeding, Department of Agriculture, Sanskriti University, Mathura, U.P, India Uttar Pradesh India 2)Dr. Rana Singh 3)Dr. Vilas Raghunath Jadhavar 4)Dr Sumit Saini 5)Anu Prakash 6)Mr. Neeraj Kant 7)Mr. Abdul Faheem 8)Sunil Kumar Mahapatro 9)Mr. Udit Mamodiya 10)Mr. Shashank Srivastav 11)Dheeraj Kumar Dhaked
(31) Priority Document No	:NA	(72)Name of Inventor : 1)Dr. Ranjana 2)Dr. Rana Singh 3)Dr. Vilas Raghunath Jadhavar 4)Dr Sumit Saini 5)Anu Prakash 6)Mr. Neeraj Kant 7)Mr. Abdul Faheem 8)Sunil Kumar Mahapatro 9)Mr. Udit Mamodiya 10)Mr. Shashank Srivastav 11)Dheeraj Kumar Dhaked
(32) Priority Date	:NA	
(33) Name of priority country	:NA	
(86) International Application No	:NA	
Filing Date	:NA	
(87) International Publication No	: NA	
(61) Patent of Addition to Application Number	:NA	
Filing Date	:NA	
(62) Divisional to Application Number	:NA	
Filing Date	:NA	

(57) Abstract :

The present invention relates to internet of things based user controlled solar energy powered smart irrigation system for precision agriculture. The objective of the present invention is to solve the problems in the prior art technologies of precision agriculture related to irrigation control.

No. of Pages : 29 No. of Claims : 4

(12) PATENT APPLICATION PUBLICATION

(21) Application No.202111024237 A

(19) INDIA

(22) Date of filing of Application :31/05/2021

(43) Publication Date : 11/06/2021

(54) Title of the invention : SYSTEM AND METHOD FOR MANUFACTURING BUILDING MATERIALS

(51) International classification	:B29C0064209000, B29C0064106000, B33Y0030000000, B01F0015020000, B29L0031100000	(71) Name of Applicant : 1)ANGIRUS IND PRIVATE LIMITED Address of Applicant :98, Ratneshwar Colony, Garhmagri, Shobhagpura, Udaipur, Rajasthan - 313011, India. Rajasthan India
(31) Priority Document No	:NA	(72) Name of Inventor :
(32) Priority Date	:NA	1)GOSWAMI, Lokesh Puri
(33) Name of priority country	:NA	2)ARORA, Kunjpreet Kaur
(86) International Application No	:NA	
Filing Date	:NA	
(87) International Publication No	: NA	
(61) Patent of Addition to Application Number	:NA	
Filing Date	:NA	
(62) Divisional to Application Number	:NA	
Filing Date	:NA	

(57) Abstract :

The present disclosure relates to a system for manufacturing building material. The system includes a first chamber having inert waste material, and the first chamber is configured to crush the inert waste material into aggregates of pre-defined size. A second chamber having molten plastic material. A mixing chamber, having a heating element, operatively coupled with the first chamber and the second chamber, and configured to receive the inert waste material aggregates and the molten plastic material and generates a composite paste of the inert waste material and the molten plastic. One or more molds, of a pre-defined shape, fluidically configured with the mixing chamber, and configured to receive the composite paste. The one or more molds are subjected to a hydraulic pressure to manufacture the building material.

No. of Pages : 18 No. of Claims : 5

(12) PATENT APPLICATION PUBLICATION

(21) Application No.202111024256 A

(19) INDIA

(22) Date of filing of Application :31/05/2021

(43) Publication Date : 11/06/2021

(54) Title of the invention : AN INSULIN PUMP WITH A LINEAR ACTUATOR ASSEMBLY

(51) International classification	:A61M0005142000, A61M0005172000, G16H0040630000, G06N0020000000, C07K0014620000	(71) Name of Applicant : 1)Dr. Deepak Agrawal Address of Applicant :74, Pragati Apartment Paschim Vihar, New Delhi 110063 Delhi India 2)Prof. Diwakar Vaish
(31) Priority Document No	:NA	(72) Name of Inventor :
(32) Priority Date	:NA	1)Dr. Deepak Agrawal
(33) Name of priority country	:NA	2)Prof. Diwakar Vaish
(86) International Application No	:NA	
Filing Date	:NA	
(87) International Publication No	: NA	
(61) Patent of Addition to Application Number	:NA	
Filing Date	:NA	
(62) Divisional to Application Number	:NA	
Filing Date	:NA	

(57) Abstract :

The present invention discloses an insulin pump with a linear actuator assembly. The assembly includes, but not limited to, a stepper motor placed to drive a piston; a removable insulin cartridge connected with the piston; a connector for connecting the removable insulin cartridge with a body attachment; a processing unit designed to guide for a predetermined delivery from the removable insulin cartridge to the patient by actuating the linear assembly; a machine learning interface to calibrate and to handle the whole process precisely according to the desired level of insulin delivery for the patient. Further, the machine learning interface is further configured to set and schedule the insulin delivery according to previous learning and training for the patient.

No. of Pages : 19 No. of Claims : 9

(12) PATENT APPLICATION PUBLICATION

(21) Application No.202111024369 A

(19) INDIA

(22) Date of filing of Application :01/06/2021

(43) Publication Date : 11/06/2021

(54) Title of the invention : A HONEYPOT BASED NETWORK SECURITY SYSTEM

(51) International classification	:H04L0029060000, H04W0012120000, G06N0020000000, G06F0017180000, G10K0015020000	(71)Name of Applicant : 1)Mr. Binu Kuriakose Vargis Address of Applicant :Department of Information Technology, Inderprastha Engineering College, Ghaziabad, India. Uttar Pradesh India 2)Dr. Kamal Upreti 3)Mr. Philson Manarcad 4)Mr. Vivek Garg 5)Dr. A. Harshavardhan 6)Mr. Basil Paul 7)Dr. Chaitanya P. Agrawal 8)Dr. Sangeeta Arora
(31) Priority Document No	:NA	(72)Name of Inventor : 1)Mr. Binu Kuriakose Vargis 2)Dr. Kamal Upreti 3)Mr. Philson Manarcad 4)Mr. Vivek Garg 5)Dr. A. Harshavardhan 6)Mr. Basil Paul 7)Dr. Chaitanya P. Agrawal 8)Dr. Sangeeta Arora
(32) Priority Date	:NA	
(33) Name of priority country	:NA	
(86) International Application No	:NA	
Filing Date	:NA	
(87) International Publication No	: NA	
(61) Patent of Addition to Application Number	:NA	
Filing Date	:NA	
(62) Divisional to Application Number	:NA	
Filing Date	:NA	

(57) Abstract :

Aspects of the present disclosure relate to a honeypot based network security system (100) and a data processing method (200) thereof. In an aspect, the honeypot-based network security system (100) comprises of: an attacking terminal (102) which sends a source data to the honeypot (104), and a honeypot (104) for acquiring the source data sent by the attacking terminal and comprising of bogus data. The method (200) of data processing on a honeypot-based network security system method comprises of: acquiring (202) a plurality of transmission control protocol (TCP) type source data set that are sent by the attack terminal, simulating (204) a TCP protocol for constructing a TCP feedback data packet which meets the pre-set requirement, and sending (206) the TCP feedback data packet to the attack terminal.

No. of Pages : 23 No. of Claims : 8

(12) PATENT APPLICATION PUBLICATION

(21) Application No.202111024378 A

(19) INDIA

(22) Date of filing of Application :01/06/2021

(43) Publication Date : 11/06/2021

(54) Title of the invention : A SYNERGISTIC HERBAL FORMULATION FOR TREATING VAGINAL INFECTIONS AND METHOD THEREOF

(51) International classification	:A61K0036600000, A61K0009480000, A61K0036610000, A61K0036580000, A61K0009000000	(71) Name of Applicant : 1)IKDK3012 PRIVATE LIMITED Address of Applicant :H NO. 1375, SECTOR-4, GURUGRAM, HARYANA, 122001, INDIA Haryana India
(31) Priority Document No	:NA	(72) Name of Inventor : 1)AASINKUMAR JAGNARAYAN MAURYA
(32) Priority Date	:NA	
(33) Name of priority country	:NA	
(86) International Application No	:NA	
Filing Date	:NA	
(87) International Publication No	: NA	
(61) Patent of Addition to Application Number	:NA	
Filing Date	:NA	
(62) Divisional to Application Number	:NA	
Filing Date	:NA	

(57) Abstract :

A synergistic herbal formulation for treating vaginal infections is disclosed. The formulation comprises effective amount of plant extracts selected from the group consisting of Azadirachta indica at 0.25% to 2% (w/v), Ficus benghalensis at 0.10 - 1% (w/v), Ficus glomerata at 0.10%-1% (w/v), Ficus religiosa at 0.10 - 1% (w/v), Thespesia populnea at 0.10 - 1% (w/v), Ficus infectoria at 0.10 - 1% (w/v) and Melaleuca alternifolia at 0.02 - 1% (w/v). The synergistic herbal formulation further comprises of lactic acids from AHA complex, natural fatty acids of coconut oil, soapnut extracts, glycerine, benzalkonium chloride, soya protein, wheat protein, sodium chloride, potassium sorbate, and fragrance. The synergistic herbal formulation of the present disclosure is effective in treatment of Vulvo-vaginal candidiasis and it can be formulated as water soluble gels, foaming solution, soft gel, solutions, aerosols, creams, ointments, capsules, microcapsules, suppositories or tablets, preferably water soluble gels, capsules or tablets.

No. of Pages : 51 No. of Claims : 14

(12) PATENT APPLICATION PUBLICATION

(21) Application No.202111024379 A

(19) INDIA

(22) Date of filing of Application :01/06/2021

(43) Publication Date : 11/06/2021

(54) Title of the invention : LATERAL FLOW IMMUNOASSAY BASED POINT OF CARE DIAGNOSTIC DEVICE FOR ULTRASENSITIVE COLORIMETRIC DETECTION OF DENGUE

(51) International classification	:G01N0033558000, G01N0033543000, G01N0033569000, A61B0010020000, G01N0033530000	(71) Name of Applicant : 1)Indian Institute of Technology Kanpur Address of Applicant :DEAN, RESEARCH & DEVELOPMENT, ROOM NUMBER 151, FACULTY BUILDING, POST OFFICE: IIT KANPUR, KANPUR- 208016, UTTAR PRADESH, INDIA Uttar Pradesh India
(31) Priority Document No	:NA	(72) Name of Inventor :
(32) Priority Date	:NA	1)Geeta Bhatt
(33) Name of priority country	:NA	2)Mohammed Rashiku B C
(86) International Application No	:NA	3)Poonam Sundriyal
Filing Date	:NA	4)Prof. Shantanu Bhattacharya
(87) International Publication No	: NA	
(61) Patent of Addition to Application Number	:NA	
Filing Date	:NA	
(62) Divisional to Application Number	:NA	
Filing Date	:NA	

(57) Abstract :

The present invention relates to the detection of Dengue. More specifically, the invention provides a lateral Flow Immunoassay based Point of Care Diagnostic Device for Ultrasensitive colorimetric detection of Dengue.

No. of Pages : 20 No. of Claims : 9

(12) PATENT APPLICATION PUBLICATION

(21) Application No.202111024563 A

(19) INDIA

(22) Date of filing of Application :02/06/2021

(43) Publication Date : 11/06/2021

(54) Title of the invention : CIVIL ENGINEERING WATER PUMP WITH GRID CONNECTED INTELLIGENT SOLAR SYSTEM FOR WATER MANAGEMENT

(51) International classification	:H04L0029080000, H04Q0009000000, G01N0033180000, G01D0021020000, G01K0001020000	(71) Name of Applicant : 1)Ajay Kumar Bansal Address of Applicant :School of Engineering and Technology, Central University of Haryana, Jant-Pali, Mahendergarh Haryana India
(31) Priority Document No	:NA	(72) Name of Inventor :
(32) Priority Date	:NA	1)Ajay Kumar Bansal
(33) Name of priority country	:NA	2)Vikas Garg
(86) International Application No	:NA	3)D. V. S. Verma
Filing Date	:NA	4)Baldev Setia
(87) International Publication No	: NA	5)Sunita Bansal
(61) Patent of Addition to Application Number	:NA	6)Dhruvi Bansal
Filing Date	:NA	
(62) Divisional to Application Number	:NA	
Filing Date	:NA	

(57) Abstract :

Civil Engineering water pump with Grid connected intelligent solar system for water management to utilize internet of things (IoT) to monitor a consumer requirements and further enables a consumer to manage the requirements in real-time, water pump comprises water pump has two output valves, one for storage tank and second for direct use with solar panels, at least one sensor to measure temperature and humidity of surrounding area; IOT system for checking the water levels of tank and underground water and water quality having wireless unit configured with the sensor units to transmit the detected data to a remotely placed server unit via a communication network; Micro-Controller for operation of pump automatically based on data feed for different types of crops and requirements of water at different period of time; Water tank with pH value indicator with water quality sensor and timer, alarm buzz at given set time or the sensor give the signal for water requirement; processing module and control unit connected to the at least one sensor; control unit comprises instructions to process data related to at least one of the weather conditions, the water type, pump information ; server unit is configured with a database to store the collected data; computing devices connected to the server unit to receive the detected data from the server unit; and a software application integrated with the computing device to manage the use of water in two tank containing aqueous liquid that is controlled by a flow restricting mechanism connected to the processing module.

No. of Pages : 28 No. of Claims : 7

(12) PATENT APPLICATION PUBLICATION

(21) Application No.202111024621 A

(19) INDIA

(22) Date of filing of Application :02/06/2021

(43) Publication Date : 11/06/2021

(54) Title of the invention : POLYHERBAL FORMULATION FOR ALOPECIA

(51) International classification	:A61Q0007000000, A61K0036280000, A61K0036480000, A61K0036185000, A61K0009000000	(71) Name of Applicant : 1)Dr. Girendra Kumar Gautam Address of Applicant :Director, Shri Ram College of Pharmacy, Parikrama Marg, Muzaffarnagar (U.P.), Pincode:251001. Uttar Pradesh India
(31) Priority Document No	:NA	(72) Name of Inventor :
(32) Priority Date	:NA	1)Dr. Girendra Kumar Gautam
(33) Name of priority country	:NA	2)Dr. Akash Ved
(86) International Application No	:NA	3)Dr. Abhishek Tiwari
Filing Date	:NA	4)Dr. Mohit Chaturvedi
(87) International Publication No	: NA	5)Dr. Sattwik Das
(61) Patent of Addition to Application Number	:NA	6)Dr. Shailesh kumar Gupta
Filing Date	:NA	7)Dr.Vimal Kumar Yadav
(62) Divisional to Application Number	:NA	8)Mr. Paras Sharma
Filing Date	:NA	9)Mr. Mohammad Akhtar Rasool
		10)Mr. Anwar Iqbal Khan

(57) Abstract :

The present invention relates to a composition for promoting hair growth, preventing the hair loss and alopecia. Many herbal products claim to have hair growth promoting activity. Trigonella foenum greacum seed, flower of Hibiscus rosa sinensis Linn and leave of Eclipta alba (L.) extracts were obtained separately by soxhlation method. FT-IR spectrograms peaks study of plants extracts and polymers were found to be compatible. Total eight preparations were formulated by using different ratios of Carbopol 934 and sodium CMC. On comparison of kinetic modeling and release profile data it was evident that Hydro-alcoholic gel FH was found to release the drug in accordance to Higuchi kinetics model.

No. of Pages : 28 No. of Claims : 2

(12) PATENT APPLICATION PUBLICATION

(21) Application No.202111024622 A

(19) INDIA

(22) Date of filing of Application :02/06/2021

(43) Publication Date : 11/06/2021

(54) Title of the invention : FLAX SEED SUPPOSITORIES FOR RAPID DRUG DELIVERY

(51) International classification	:A61K0009020000, A61K0009000000, A61K0047020000, A61K0036899000, A61N0001360000	(71) Name of Applicant : 1)Dr.Amit Kumar Verma Address of Applicant :Faculty Department of Pharmacy, MJP Rohilkhand University Bareilly UP, Pincode: 243006. Uttar Pradesh India
(31) Priority Document No	:NA	(72) Name of Inventor :
(32) Priority Date	:NA	1)Dr.Amit Kumar Verma
(33) Name of priority country	:NA	2)Mrs. Preeti Mishra
(86) International Application No	:NA	
Filing Date	:NA	
(87) International Publication No	: NA	
(61) Patent of Addition to Application Number	:NA	
Filing Date	:NA	
(62) Divisional to Application Number	:NA	
Filing Date	:NA	

(57) Abstract :

The present invention relates to the technical field of medicine, and particularly relates to a stable, non-sticky suppository and a method of preparing thereof. The suppository is prepared by using an flax seed water extract as a main ingredient and glycerinated gelatin base with and without active pharmaceutical ingredient and/or ayurvedic ingredients. The suppository can be used as a laxative, pain relief or for constipation,

No. of Pages : 25 No. of Claims : 6

(12) PATENT APPLICATION PUBLICATION

(21) Application No.202117021546 A

(19) INDIA

(22) Date of filing of Application :12/05/2021

(43) Publication Date : 11/06/2021

(54) Title of the invention : AIR POLLUTANTS CAPTURING TECHNIQUE THROUGH SMART INVENTIVE FRAMEWORK FOR DOWNSTREAM CHEMICAL PROCESSING

(51) International classification	:E01C0001000000, C10L0001020000, H04L0001000000, B01D0046000000, B01D0053640000	(71) Name of Applicant : 1)SHARMA, CHANDAN Address of Applicant :F1, 1st Floor, Plot No-19 Gyan Khand- 1, Indirapuram Ghaziabad-201014 Uttar Pradesh India
(31) Priority Document No	:NA	(72) Name of Inventor :
(32) Priority Date	:NA	1)SHARMA, CHANDAN
(33) Name of priority country	:NA	2)SHARMA, PRAVEEN
(86) International Application No	:PCT/IN2019/050157	3)SHARMA, UJJAWAL
Filing Date	:26/02/2019	
(87) International Publication No	:WO 2019/220449	
(61) Patent of Addition to Application Number	:NA	
Filing Date	:NA	
(62) Divisional to Application Number	:NA	
Filing Date	:NA	

(57) Abstract :

The invention is regarding bringing out an innovative air pollutant capturing technique or process by which a system could be established in order to capture the air pollutants in a city at suitable locations and send the same through the pipeline system to a processing plant in order to convert it into a useful low carbon transportation fuel or any useful chemical product/by-product or petrochemicals and at the same time reducing pollutants and green house gases affecting the environment. The invention states that a system/technique/method/process is brought to efficiently capture the air pollutants using a vacuum ejector system & other associated equipments and infrastructures at major elevated metro stations or at any place inside an urban landscape and send the same through a network of pipeline system having intermediate boosting stations, in order to take the captured pollutants to a nearby processing plant for producing useful fuel or chemicals.

No. of Pages : 16 No. of Claims : 14

(12) PATENT APPLICATION PUBLICATION

(21) Application No.201921036523 A

(19) INDIA

(22) Date of filing of Application :11/03/2020

(43) Publication Date : 11/06/2021

(54) Title of the invention : UAV WITH SENTRY GUN

(51) International classification	:B64C0039020000, H04N0005232000, G06K0009000000, G05D0001000000, B22C0009100000	(71) Name of Applicant : 1)SHUBHAM ANILKUMAR SHAH Address of Applicant :51/B PAVITRANAGAR OPPOSITE CADILA LABORATORY ,GHODASAR,AHMEDABAD Gujarat India
(31) Priority Document No	:NA	(72) Name of Inventor :
(32) Priority Date	:NA	1)SHUBHAM ANILKUMAR SHAH
(33) Name of priority country	:NA	
(86) International Application No	:NA	
Filing Date	:NA	
(87) International Publication No	: NA	
(61) Patent of Addition to Application Number	:NA	
Filing Date	:NA	
(62) Divisional to Application Number	:NA	
Filing Date	:NA	

(57) Abstract :

An unmanned aerial vehicle (100) with sentry gun (08) includes a body with three parts back parts, middle parts and front parts in a metal casted square and a controller. The back part of the body includes double ball joint (11) and magneto rheological damper (10) in angular shape. The middle part of the body includes single ball joint attached in a downward frame, an actuator housing attached with the single ball joint (03), actuator and center of gravity frame. The front part includes a frame attached to the single ball joint (03) where small single ball joint at certain angle and a gun holder attached to the front side to hold the gun (08). Further, the present invention works on scissor mechanism (05) at the top most and least point vertically which is attached with the lowest point of frame. And two precise actuators are connected at lowest point frame horizontally for center of gravity housing part in a metal casted square. As per drawing: FIG. 1.

No. of Pages : 26 No. of Claims : 14

(12) PATENT APPLICATION PUBLICATION

(21) Application No.202021000782 A

(19) INDIA

(22) Date of filing of Application :08/01/2020

(43) Publication Date : 11/06/2021

(54) Title of the invention : MUTANT PENICILLIN G ACYLASES OF ACHROMOBACTER CCM4824

(51) International classification	:C12P0037040000, C12N0009840000, C12P0035040000, C12R0001025000, C12N0011040000	(71) Name of Applicant : 1)FERMENTA BIOTECH LIMITED Address of Applicant :A-1501, Thane One, ~DIL™ Complex, Ghodbunder Road, Majiwada, Thane (West)-400 610, Maharashtra, India. Maharashtra India
(31) Priority Document No	:NA	(72) Name of Inventor :
(32) Priority Date	:NA	1)DESAI, Anupama Datla
(33) Name of priority country	:NA	2)NAGRE, Prashant
(86) International Application No	:NA	3)TAMORE, Jagdish
Filing Date	:NA	4)KRISHNA, Muralidharan
(87) International Publication No	: NA	5)ASHAR, Trupti
(61) Patent of Addition to Application Number	:NA	
Filing Date	:NA	
(62) Divisional to Application Number	:NA	
Filing Date	:NA	

(57) Abstract :

The present invention discloses mutant semi-synthetic -lactam antibiotics synthesizing enzymes of penicillin G acylase from *Achromobacter* sp. CCM4824 generated by site directed mutations with substitution of one or more amino acid positions. The gene sequence encoding mutant penicillin acylase borne on plasmid pKARA9 is expressed in *E.coli* BL21. The enzymes so obtained from recombinant *E.coli* BL21 showed improved penicillin acylase activity, S/H ratio, lower input ratio of acyl donor and improved yields compared to parent penicillin acylase enzyme from *Achromobacter* sp CCM 4824.

No. of Pages : 44 No. of Claims : 10

(12) PATENT APPLICATION PUBLICATION

(21) Application No.202021018340 A

(19) INDIA

(22) Date of filing of Application :29/04/2020

(43) Publication Date : 11/06/2021

(54) Title of the invention : MULTI-DRILL CULTI-ROTAVATOR

(51) International classification	:A01N0043800000, A01C0023000000, A01B0003680000, B60C0011030000, A01N0043713000	(71) Name of Applicant : 1)Dr. Chaitanya A. Patel Address of Applicant :Bhanujit • 6, Chunibhai Colony, Nr. Old Pilot Dairy Cross Roads, Kankaria, Behrampura. Ahmedabad Gujarat India 380022 Gujarat India
(31) Priority Document No	:NA	(72) Name of Inventor :
(32) Priority Date	:NA	1)Dr. Chaitanya A. Patel
(33) Name of priority country	:NA	
(86) International Application No	:NA	
Filing Date	:NA	
(87) International Publication No	: NA	
(61) Patent of Addition to Application Number	:NA	
Filing Date	:NA	
(62) Divisional to Application Number	:NA	
Filing Date	:NA	

(57) Abstract :

Abstract Multi-drill Culti-Rotavator The Multi-drill culti rotavator, according to the present invention, is used for cultivating or ploughing the soil and at the same 10 time, for rotavating the soil for agricultural and gardening purpose. Said culti rotavator effectively drills and cultivates the soil preparing it for the irrigation retaining soil moisture increasing soil absorption capacity of the soil. Said multi drill culti rotavator is hung at the rear end of the tractor. It comprises of: Differential Gear Box Assembly 2, Main Body Assembly 3, Bottom differential Gear box Assembly 4, Gear Axle Assembly 5 , End Bearing Housing Assembly 6, Drill Bit Shaft Assembly 7. Fig 1

No. of Pages : 33 No. of Claims : 9

(12) PATENT APPLICATION PUBLICATION

(21) Application No.202021023187 A

(19) INDIA

(22) Date of filing of Application :02/06/2020

(43) Publication Date : 11/06/2021

(54) Title of the invention : VENTILATOR PUMPING APPARATUS

(51) International classification	:A61M0016000000, A61M0016080000, A23L0003341800, B01D0035020000, F04B0009127000	(71) Name of Applicant : 1)VIVEK RANGRAO DALVI Address of Applicant :SHREENIVAS, PLOT NO.77, SECTOR NO.25, SINDHUNAGAR, PRADHIKARAN, NIGDI, PUNE 411044 Maharashtra India 2)RASIKA VIVEK DALVI
(31) Priority Document No	:NA	(72) Name of Inventor :
(32) Priority Date	:NA	1)VIVEK RANGRAO DALVI
(33) Name of priority country	:NA	2)RASIKA VIVEK DALVI
(86) International Application No	:NA	
Filing Date	:NA	
(87) International Publication No	: NA	
(61) Patent of Addition to Application	:NA	
Number	:NA	
Filing Date	:NA	
(62) Divisional to Application Number	:NA	
Filing Date	:NA	

(57) Abstract :

ABSTRACT VENTILATOR PUMPING APPARATUS A ventilator pumping apparatus 100 is described. The ventilator pumping apparatus 100 includes an air compressor 105, a pressure regulator valve 110, solenoid valve 115, a cylindrical container 120, a controller 125 and a balloon 130. The regulator valve 110 is positioned between the air compressor 105 and the solenoid valve 115. The solenoid valve 115 and the compressor 105 are connected to the controller 125 that controls the ventilator in which the pumping system is integrated. The controller 125 is configured to receive inputs from a user and run the ventilator pumping apparatus 100. The cylindrical container 120 is an airtight container that is sealed with a sealant. The balloon 130 is securely positioned inside the container 120 that further includes a safety valve. FIG. 1 For Publication

No. of Pages : 33 No. of Claims : 12

(12) PATENT APPLICATION PUBLICATION

(21) Application No.202021025879 A

(19) INDIA

(22) Date of filing of Application :19/06/2020

(43) Publication Date : 11/06/2021

(54) Title of the invention : CORONA KAVACH (DEVICE)

(51) International classification :H02K0003400000,
B29C0059100000,
A61K0009510000,
F01N0003080000,
B32B0038000000

(31) Priority Document No :NA
(32) Priority Date :NA
(33) Name of priority country :NA
(86) International Application No :NA
Filing Date :NA
(87) International Publication No : NA
(61) Patent of Addition to Application Number :NA
Filing Date :NA
(62) Divisional to Application Number :NA
Filing Date :NA

(71)Name of Applicant :
1)SHIMPI RAHUL JAYWANTRAO
Address of Applicant :5 JAY, FOREST COLONY, DEOPUR,
DHULE - 424005, MAHARASHTRA, INDIA. Maharashtra India

(72)Name of Inventor :
1)SHIMPI RAHUL JAYWANTRAO

(57) Abstract :

7. ABSTRACT OF THE INVENTION: Now a day's whole world is struggling to find a vaccine for COVID-19. According to the ministry of Health & Family Welfare social distancing is non-pharmaceutical infection prevention and control intervention implemented to avoid or decrease contact between the 5 COVID-19 infected causing pathogen and those who are not, so as to stop or slow down the rate and extent of disease transmission in a community. The preventive measures for COVID-19 are maintaining social distance & keep hands clean. The proposed Corona Kavach Device is intended for maintaining social distance of one/two meter between two persons with announcement in mother tongue. Also it provide periodic 10 reminder to wash our hands. It also equipped with temperature sensor to measure body temperature of user.

No. of Pages : 4 No. of Claims : 2

(12) PATENT APPLICATION PUBLICATION

(21) Application No.202021043671 A

(19) INDIA

(22) Date of filing of Application :07/10/2020

(43) Publication Date : 11/06/2021

(54) Title of the invention : REAL TIME OPTIMUM RESPIRATION ASSISTANCE SYSTEM THROUGH PEAK INSPIRATORY FLOW RATE AND METHOD THEREOF

(51) International classification	:A61M0016000000, A61B0005000000, A61B0005087000, A61M0015000000, B22F0007060000	(71) Name of Applicant : 1)MOHAN SHIVDAS SWAMI Address of Applicant :ERRA 55/3B ASHOK PATH, ERANDVANA, PUNE-411004, MAHARASHTRA, INDIA Maharashtra India
(31) Priority Document No	:NA	2)ADESH GOKHALE
(32) Priority Date	:NA	(72) Name of Inventor :
(33) Name of priority country	:NA	1)MOHAN SHIVDAS SWAMI
(86) International Application No	:NA	2)ADESH GOKHALE
Filing Date	:NA	
(87) International Publication No	: NA	
(61) Patent of Addition to Application Number	:NA	
Filing Date	:NA	
(62) Divisional to Application Number	:NA	
Filing Date	:NA	

(57) Abstract :

The present invention provides a respiratory assistance system (100) and a respiratory assistance method. The respiratory assistance system (100) measures one or more vital respiratory parameters of a patient by a sensing unit (120). A processor (110) determines an optimum flow rate of oxygen based on the vital respiratory parameters and controls a pressure monitor and control unit (116) coupled with an oxygen source (104) to provide the flow of oxygen at the optimum flow rate during a peak inspiratory flow to assist the patient in respiration. Ref. Fig.: Figure 1

No. of Pages : 23 No. of Claims : 12

(12) PATENT APPLICATION PUBLICATION

(21) Application No.202021044084 A

(19) INDIA

(22) Date of filing of Application :09/10/2020

(43) Publication Date : 11/06/2021

(54) Title of the invention : LIQUID ORAL SUSPENSION OF FAVIPIRAVIR

(51) International classification	:A61K0009000000, A61K0031496500, A61K0047020000, A61K0047380000, A61K0009100000	(71) Name of Applicant : 1)AUXILLA PHARMACEUTICALS AND RESEARCH LLP Address of Applicant :Plot no. 194, Medows 2, Gokuldham, Village Sanathal, TA: Sanathal, Ahmedabad-382110, Gujarat India Gujarat India
(31) Priority Document No	:NA	(72) Name of Inventor :
(32) Priority Date	:NA	1)UMRETHIA, MANISH
(33) Name of priority country	:NA	2)KHUNT, DIGNESH
(86) International Application No	:NA	
Filing Date	:NA	
(87) International Publication No	: NA	
(61) Patent of Addition to Application Number	:NA	
Filing Date	:NA	
(62) Divisional to Application Number	:NA	
Filing Date	:NA	

(57) Abstract :

ABSTRACT LIQUID ORAL SUSPENSION OF FAVIPIRAVIR The present invention is a liquid oral suspension of Favipiravir. Particularly the present invention is a liquid oral suspension of Favipiravir comprising Favipiravir and glycerin, the pH of the composition is 4 to 8. The present invention is also process for preparing the liquid oral suspension of Favipiravir.

No. of Pages : 26 No. of Claims : 9

(12) PATENT APPLICATION PUBLICATION

(21) Application No.202121005883 A

(19) INDIA

(22) Date of filing of Application :11/02/2021

(43) Publication Date : 11/06/2021

(54) Title of the invention : GAS PERMEABILITY MEASUREMENT APPARATUS AND METHOD

(51) International classification	:B01F0003040000, C25B0015080000, G01N0015080000, C12M0001120000, B01D0065100000	(71) Name of Applicant : 1)Dr. Netram Kaurav Address of Applicant :Government Holkar (Model, Autonomous) Science College, A.B. Road, Near Bhawarkua Square, Indore, Madhya Pradesh 452017 Madhya Pradesh India
(31) Priority Document No	:NA	2)Ms. Disha Harinkhere
(32) Priority Date	:NA	3)Dr. G. S. Okram
(33) Name of priority country	:NA	(72) Name of Inventor :
(86) International Application No	:NA	1)Dr. Netram Kaurav
Filing Date	:NA	2)Ms. Disha Harinkhere
(87) International Publication No	: NA	3)Dr. G. S. Okram
(61) Patent of Addition to Application Number:	NA	
Filing Date	:NA	
(62) Divisional to Application Number	:NA	
Filing Date	:NA	

(57) Abstract :

A gas permeability measurement apparatus is disclosed. A membrane cell (102) is provided and comprises at least two cylinders (104, 106) with a first gas cylinder (104) having an inlet valve (110). A pressure gauge (114) is configured to feed a test gas which is being supplied at said constant pressure on a feed side of said membrane cell (102). A purging valve (118) coupled to an upper side of said membrane cell (102), and is configured to remove out impurities by purging at least 2-3 times in order to attain a smooth transport rate. A circular-shaped clutch (108) is provided with dimensions more than said membrane cell (102), in order that said membrane cell (102) is detached and/or attached from and/or to said circular-shaped clutch (108) slot. A bubble flow meter (126) is provided in order to measure transport of gas at said downstream side via said outlet valve (112).

No. of Pages : 30 No. of Claims : 9

(12) PATENT APPLICATION PUBLICATION

(21) Application No.202121006745 A

(19) INDIA

(22) Date of filing of Application :18/02/2021

(43) Publication Date : 11/06/2021

(54) Title of the invention : SYSTEM AND METHOD FOR NFC TRANSACTIONS ON USER MOBILE DEVICES

(51) International classification	:G06Q0020320000, G06Q0020200000, G06Q0020340000, H04W0004800000, G06Q0050120000	(71) Name of Applicant : 1)SYNERGISTIC FINANCIAL NETWORKS PRIVATE LIMITED Address of Applicant :801 SAGARTECH PLAZA BUILDING A • , SAKINAKA, ANDHERI EAST, MUMBAI 400072, INDIA Maharashtra India
(31) Priority Document No	:NA	(72) Name of Inventor :
(32) Priority Date	:NA	1)ALOK ARORA
(33) Name of priority country	:NA	2)BHUSHAN THAKER
(86) International Application No	:NA	3)SAMEER CHUGH
Filing Date	:NA	
(87) International Publication No	: NA	
(61) Patent of Addition to Application Number	:NA	
Filing Date	:NA	
(62) Divisional to Application Number	:NA	
Filing Date	:NA	

(57) Abstract :

A system for facilitating a Near-Field Communication (NFC) transaction comprising a userTMs NFC-enabled electronic device, a userTMs NFC-enabled card, and a transaction server is disclosed. The userTMs NFC-enabled electronic device includes a background NFC service (BNS) and applications. The applications may be configured to provide an NFC transaction request including recipient information to the BNS via service calls. The BNS may be configured to provide the recipient information and card details associated with the userTMs NFC-enabled card to the transaction server. Further, the transaction server may be configured to provide the recipient information and the card details to a transaction processor, an acquirer bank, or an issuer bank. A method, an NFC-enabled electronic device, and a transaction server for facilitating the NFC transaction is also disclosed.

No. of Pages : 53 No. of Claims : 22

(12) PATENT APPLICATION PUBLICATION

(21) Application No.202121012817 A

(19) INDIA

(22) Date of filing of Application :24/03/2021

(43) Publication Date : 11/06/2021

(54) Title of the invention : HYDRO WIND ELECTRIC POWER GENERATION SYSTEM

(51) International classification :F03B0017000000,
E21B0043120000,
E21B0041000000,
B60T0011260000,
F03B0013060000

(31) Priority Document No :NA
(32) Priority Date :NA
(33) Name of priority country :NA
(86) International Application No :NA
Filing Date :NA
(87) International Publication No : NA
(61) Patent of Addition to Application Number :NA
Filing Date :NA
(62) Divisional to Application Number :NA
Filing Date :NA

(71)**Name of Applicant :**
1)CHAUHAN, Surjeet Singh
Address of Applicant :A-14, Sarover Housing Society, Near
Gurudwara Chowk, Akurdi, Pune - 411033, Maharashtra, India.
Maharashtra India
(72)**Name of Inventor :**
1)CHAUHAN, Surjeet Singh

(57) Abstract :

The present disclosure relates to a system (100) for generating power, the system includes an electrical generating turbine (106) that receives water from an upper portion (102) of a reservoir, the electrical generating turbine generates electrical power, the upper portion of the reservoir configured to receive water from a source. One or more pipes (118) adapted to allow the passage of water from a lower portion of the reservoir to the upper portion (104) of the reservoir. Hydraulic cylinders (202) are pivotally coupled to a shaft (204) of a windmill device, wherein the rotational motion of one or more blades of the windmill device is converted into a reciprocation motion by windmill rod. Hydraulic cylinder lift pump rod (116) which loaded with water due to pump piston to lift the water from the lower portion of the reservoir to the upper portion of the reservoir.

No. of Pages : 25 No. of Claims : 10

(12) PATENT APPLICATION PUBLICATION

(21) Application No.202121016866 A

(19) INDIA

(22) Date of filing of Application :10/04/2021

(43) Publication Date : 11/06/2021

(54) Title of the invention : READY TO USE LIQUID SOLUTION OF LEVOTHYROXINE

(51) International classification	:A61K0031198000, A61K0047020000, A61K0009080000, A61K0038040000, A61K0009000000	(71) Name of Applicant : 1)AUXILLA PHARMACEUTICALS AND RESEARCH LLP Address of Applicant :Plot no. 194, Medows 2, Gokuldham, Village Sanathal, TA: Sanathal, Ahmedabad-382110, Gujarat, India. Gujarat India
(31) Priority Document No	:NA	(72) Name of Inventor :
(32) Priority Date	:NA	1)PARIKH, DHRUV RAJESHKUMAR
(33) Name of priority country	:NA	2)PATEL, NITESH
(86) International Application No	:NA	3)UMRETHIA, MANISH
Filing Date	:NA	
(87) International Publication No	: NA	
(61) Patent of Addition to Application Number	:NA	
Filing Date	:NA	
(62) Divisional to Application Number	:NA	
Filing Date	:NA	

(57) Abstract :

ABSTRACT READY TO USE LIQUID SOLUTION OF LEVOTHYROXINE The present invention is a ready to use liquid solution of levothyroxine. The present invention is also a ready to use liquid solution of levothyroxine which is comprising levothyroxine, a solubilizer, a stabilizer and water for injection. The present invention is in particular a ready to use liquid solution of levothyroxine and process of preparation of the same.

No. of Pages : 20 No. of Claims : 11

(12) PATENT APPLICATION PUBLICATION

(21) Application No.202121018989 A

(19) INDIA

(22) Date of filing of Application :24/04/2021

(43) Publication Date : 11/06/2021

(54) Title of the invention : DUAL APPLICATION TOPICAL FORMULATIONS FOR TREATING PAIN AND INFLAMMATION

(51) International classification	:A61K0009000000, A61K0047320000, A61K0008490000, A61K0047140000, A61K0031196000	(71) Name of Applicant : 1)VAISHALI ASHISH SHIRSAT Address of Applicant :B-26, HOME CHS, RELIEF ROAD, DAULATNAGAR, SANTACRUZ WEST, MUMBAI-400054, MAHARASHTRA, INDIA Maharashtra India
(31) Priority Document No	:NA	(72) Name of Inventor :
(32) Priority Date	:NA	1)VAISHALI ASHISH SHIRSAT
(33) Name of priority country	:NA	2)ESHA SHAH
(86) International Application No	:NA	3)SNEHA BALU GOVIND
Filing Date	:NA	4)MRUNAL MADAN BULBULE
(87) International Publication No	: NA	
(61) Patent of Addition to Application Number	:NA	
Filing Date	:NA	
(62) Divisional to Application Number	:NA	
Filing Date	:NA	

(57) Abstract :

DUAL APPLICATION TOPICAL FORMULATIONS FOR TREATING PAIN AND INFLAMMATION The present invention relates to a novel topical dual application system and method of treating a pain and inflammation in a subject in need thereof, comprising dual or co-application of two topical formulations comprising Non-steroidal anti-inflammatory agents, counter-irritant agent and analgesic agent. The present invention provides a dual application topical formulation system for treating pain and inflammation, comprising of: first part of proniosomal gel carrier loaded with Non-steroidal anti-inflammatory agents and second part of gel base carrier loaded with analgesic agent selected from Methyl salicylate and counter-irritant agent selected from camphor, wherein the second part provides hydration to first part at the time of topical application resulting into formation of niosomal nanoparticles loaded with Non-steroidal anti-inflammatory agents having particle size in a range of about 250 to 990 nanometers having properties to penetrate through skin for effective treatment.

No. of Pages : 39 No. of Claims : 10

(12) PATENT APPLICATION PUBLICATION

(21) Application No.202121020010 A

(19) INDIA

(22) Date of filing of Application :30/04/2021

(43) Publication Date : 11/06/2021

(54) Title of the invention : DEVICE, SYSTEM AND METHOD FOR RECORDING FINANCIAL TRANSACTION

(51) International classification	:G06Q0020200000, G06Q0010000000, G06Q0020340000, G06K0019070000, A61B0090980000	(71) Name of Applicant : 1)TOHANDS PRIVATE LIMITED Address of Applicant :A-205, Tirupati Ashish CHS, Opp, Hotel Amber, Shahad, Kalyan (W), Thane - 421103, Maharashtra, India. Maharashtra India
(31) Priority Document No	:NA	(72) Name of Inventor :
(32) Priority Date	:NA	1)PRAVEEN MISHRA
(33) Name of priority country	:NA	2)SATYAM SAHU
(86) International Application No	:NA	
Filing Date	:NA	
(87) International Publication No	: NA	
(61) Patent of Addition to Application Number	:NA	
Filing Date	:NA	
(62) Divisional to Application Number	:NA	
Filing Date	:NA	

(57) Abstract :

The present disclosure relates to a system (100) for recording financial transactions, the system includes a device (102) comprising an information input unit (106) having one or more buttons (106-1 -106-6), each of the one or more buttons operable for entering a set of data by a user. A processor (112) configured to receive, from the information input unit, the set of data pertaining to any or a combination of credit information and debit information associated with the transaction of the user. The processor (112) categorize the received set of data and establish, by a communication unit (108), synchronization between the device and the one or more computing devices to transmit the stored set of data, wherein based on the set of data received at the one or more computing devices, a corresponding report is generated that is accessible by the user.

No. of Pages : 23 No. of Claims : 10

(54) Title of the invention : PLASTIC MODIFIED BITUMEN IN PARTIALLY RUBBER AGGREGATED ASPHALT FOR ROAD CONSTRUCTION USING MARSHALL STABILITY TEST

(51) International classification	:C08L0095000000, C08L0021000000, G06Q0010060000, C08L0017000000, G01N0003560000	(71)Name of Applicant : 1)Rajshekhar Gopal Rathod Address of Applicant :Civil Engineering Department, MIT School of Engineering, MIT ADT University,Loni Kalbhor, Pune, Maharashtra 412201 India Maharashtra India
(31) Priority Document No	:NA	2)Shubhum Sham Borhade
(32) Priority Date	:NA	3)Rushikesh Dattatray Gaikwad
(33) Name of priority country	:NA	(72)Name of Inventor :
(86) International Application No	:NA	1)Rajshekhar Gopal Rathod
Filing Date	:NA	2)Shubhum Sham Borhade
(87) International Publication No	: NA	3)Rushikesh Dattatray Gaikwad
(61) Patent of Addition to Application Number:	NA	
Filing Date	:NA	
(62) Divisional to Application Number	:NA	
Filing Date	:NA	

(57) Abstract :

Based on the various literature survey it is found that much research has been carried out on Waste Plastic and Crumb Rubber modified pavement separately, but not one researcher has explored the possibility of blending the Waste Plastic and Crumb Rubber together. Hence in this novel work we used their combination to find the maximum sustainable and stabilized blend to minimize the pollution effect and disposal of it. Waste Plastic and Crumb Rubber are a major threat to the environment as they are not naturally biodegradable and increases environmental pollution. Therefore, utilisation of these materials in Bituminous pavement can easily solve both the problems. The government of India has been looking for alternative methods of recycling them, so it can be easily used in road construction. The research fulfils the proposition. The novelty of this research was to devise a blend using Waste Plastic, Crumb Rubber, Bitumen and Aggregate for s more sustainability stabilization and durability by amplifying its utility. All the above stated objectives were achieved by performing a series of tests on Various blends stated as below. A. Blend of Bitumen and Aggregate without Waste Plastic and Crumb Rubber. B. Blend of Bitumen and Aggregate with 4% Waste Plastic as a partial replacement of Bitumen by the weight of it. C. Blend of Bitumen and Aggregate with 6% Waste Plastic as a partial replacement of Bitumen by the weight of it. D. Blend of Bitumen and Aggregate with 8% Waste Plastic as a partial replacement of Bitumen by the weight of it. E. Blend of Bitumen and Aggregate with 5% Crumb Rubber as a partial replacement of Aggregate by the weight of it. F. Blend of Bitumen and Aggregate with 10% Crumb Rubber as a partial replacement of Aggregate by the weight of it. G. Blend of Bitumen and Aggregate with 15% Crumb Rubber as a partial replacement of Aggregate by the weight of it. H. Blend of Bitumen and Aggregate with 4% Waste Plastic as a partial replacement of Bitumen by the weight of Bitumen and 5% Crumb Rubber by the weight of Aggregate. I. Blend of Bitumen and Aggregate with 6% Waste Plastic as a partial replacement of Bitumen by the weight of Bitumen and 5% Crumb Rubber by the weight of Aggregate. J. Blend of Bitumen and Aggregate with 8% Waste Plastic as a partial replacement of Bitumen by the weight of Bitumen and 5% Crumb Rubber by the weight of Aggregate. Various tests were performed in this research work such as Softening Point Test, Penetration Value Test, Ductility Test, Aggregate Impact Value Test, Aggregate Crushing Value Test, Los Angeles Abrasion Test, and Marshall Stability Test. It was found out that plastic can be used up to 6% by the weight of Bitumen, and Crumb Rubber by 5% by the weight of aggregate when Marshall Stability test was performed. During this novel research blend of both materials are used. It is found that J. Blend of Bitumen and Aggregate with 6% Waste Plastic as a partial replacement of Bitumen by the weight of Bitumen and 5% Crumb Rubber by the weight of Aggregate shows maximum stability by Marshall Stability Test. By using these blends/this blend, we observe maximum stability and sustainability in the constructed road. Furthermore, it also augments the imperviousness of bitumen, straightens out the issue of potholes. The pavement is more durable as it increases its load carrying capacity and reduces thermal cracking. Thus, employment of these blends/ this blend leads to consumption of waste plastic and crumb rubber, which not only solves the decomposition issues, but also moderates pollution By using this type of blend which shows maximum stability and sustainability the impervious property of the Bitumen gets increased by which the problem of potholes gets reduced. The pavement is more durable and it reduces thermal cracking and its load carrying capacity increases. Crumb Rubber is also a noise reducing Agent therefore noise pollution is also minimized. By using this blend the consumption of Waste Plastic and Crumb Rubber can be consumed in Road Construction which reduces the pollution effect and decomposition issue of it.

No. of Pages : 14 No. of Claims : 5

(12) PATENT APPLICATION PUBLICATION

(21) Application No.202121020394 A

(19) INDIA

(22) Date of filing of Application :04/05/2021

(43) Publication Date : 11/06/2021

(54) Title of the invention : A SYSTEM AND METHOD OF VIRTUAL LABORATORY THROUGH VIRTUAL REALITY AND PREDICTIVE ANALYSIS

(51) International classification	:G01N0021450000, G01N0035000000, G06F0003010000, G06F0008610000, B01L0001000000	(71) Name of Applicant : 1)Jay Gupta Address of Applicant :Flat no 9 & 10,2 nd floor, F Bldg, Madhav Nagar, R.A.K Road, Wadala west, Mumbai. Maharashtra, India-400031. Maharashtra India
(31) Priority Document No	:NA	2)Harshada Gupta
(32) Priority Date	:NA	(72) Name of Inventor :
(33) Name of priority country	:NA	1)Jay Gupta
(86) International Application No	:NA	2)Harshada Gupta
Filing Date	:NA	
(87) International Publication No	: NA	
(61) Patent of Addition to Application Number	:NA	
Filing Date	:NA	
(62) Divisional to Application Number	:NA	
Filing Date	:NA	

(57) Abstract :

A System and Method of Virtual laboratory through Virtual reality and Predictive Analysis • Accordingly, system and method of virtual laboratory (remote laboratory) through virtual reality and predictive analysis is disclosed. The student runtime application by using system of the invention, said student is required to download and install the runtime software to enable the execution of the virtual lab on the student's workstation followed by obtaining of Lab data and new simulation objects. lab or experiment data file may include virtual experiment objects, measuring objects, etc.... student may be required to read instructions and to write a set of modeled equations in an online workbook followed by electing, or the student may be required, to do one or more of the following: add objects to workspace from the toolbox, set or inspect properties of lab objects, and/or measuring object properties with measuring tools. Some or all of the results of the experiment may be recorded in the workbook and necessary calculation may be performed. Fig 1

No. of Pages : 33 No. of Claims : 10

(12) PATENT APPLICATION PUBLICATION

(21) Application No.202121020444 A

(19) INDIA

(22) Date of filing of Application :05/05/2021

(43) Publication Date : 11/06/2021

(54) Title of the invention : ARTIFICIAL INTELLIGENCE BASED SMART WI-FI MINIATURE CIRCUIT BREAKER

(51) International classification	:G06N0020000000, H04W0084120000, G06N0005020000, G06N0003080000, H01H0071080000	(71) Name of Applicant : 1)SYMBIOSIS INSTITUTE OF BUSINESS MANAGEMENT-PUNE SYMBIOSIS INTERNATIONAL(DEEMED UNIVERSITY) Address of Applicant :SYMBIOSIS KNOWLEDGE VILLAGE, GRAM LAVAL, TAL MULSHI, PUNE, MAHARASHTRA, INDIA, PIN CODE:A 411 045 Maharashtra India
(31) Priority Document No	:NA	(72) Name of Inventor :
(32) Priority Date	:NA	1)RAMAKRISHNAN RAMAN
(33) Name of priority country	:NA	
(86) International Application No	:NA	
Filing Date	:NA	
(87) International Publication No	: NA	
(61) Patent of Addition to Application Number	:NA	
Filing Date	:NA	
(62) Divisional to Application Number	:NA	
Filing Date	:NA	

(57) Abstract :

Abstract Smartphones which work on 3G, 4G, and 5G bands are fit with media players, cameras, email, and broadband internet, and they are also used to make calls. So, if a smartphone can handle all of these important tasks, why can't it be used to power a circuit breaker AI based sensing neural networks refers to a group of digital equipment with computing techniques that are based on artificial intelligence and are widely used in the field of informatics. However, applications based on these novel systems are continuously being created for use in engineering and digital computing. By using these systems and unleashing the power of AI based sensing neural networks, the sensing of fire and overheating of wires can be predicted and can they can used to turn ON and OFF using the smart phone.

No. of Pages : 19 No. of Claims : 6

(12) PATENT APPLICATION PUBLICATION

(21) Application No.202121020453 A

(19) INDIA

(22) Date of filing of Application :05/05/2021

(43) Publication Date : 11/06/2021

(54) Title of the invention : A PHYSIOTHERAPY DEVICE FOR A PATIENT SUFFERING FROM ORAL SUBMUCOUS FIBROSIS

(51) International classification	:A61K0048000000, A61N0005060000, A61N0001360000, A61K0031167000, A61H0023020000	(71) Name of Applicant : 1)DR. DEEPA JATTI PATIL Address of Applicant :208/2, OFFICERS ENCLAVE, AIRFORCE STATION DARJIPURA, VADODARA-390020. Gujarat India
(31) Priority Document No	:NA	(72) Name of Inventor :
(32) Priority Date	:NA	1)DR. DEEPA JATTI PATIL
(33) Name of priority country	:NA	
(86) International Application No	:NA	
Filing Date	:NA	
(87) International Publication No	: NA	
(61) Patent of Addition to Application Number	:NA	
Filing Date	:NA	
(62) Divisional to Application Number	:NA	
Filing Date	:NA	

(57) Abstract :

ABSTRACT A device for a patient suffering from oral submucous fibrosis that can used in physiotherapy to increase the mouth opening in patients. Oral submucous fibrosis is a premalignant condition occurring due to chewing of areca nut and tobacco products. In severe cases the mouth opening reduces to less than 10 mmm causing difficulty in chewing food and hampering the quality of life. The device is placed between the patient's teeth and activated externally with the help of a single screw to gradually increase the mouth opening over time.

No. of Pages : 16 No. of Claims : 10

(12) PATENT APPLICATION PUBLICATION

(21) Application No.202121020593 A

(19) INDIA

(22) Date of filing of Application :06/05/2021

(43) Publication Date : 11/06/2021

(54) Title of the invention : USING CLASSIFIED TEXT AND DEEP LEARNING INTELLIGENT ALGORITHMS TO IDENTIFY RISK AND PROVIDE EARLY WARNING.

(51) International classification	:G06N0003040000, G06N0003080000, G06Q0010060000, G06N0020000000, G06K0009620000	(71)Name of Applicant : 1)Dr. Anita. K. Patil (HOD) Address of Applicant :Department of Electronics and Telecommunications Engineering, Dr. Vithalrao Vikhe Patil College Of Engineering Ahmednagar- 414111, MH, India. Maharashtra India
(31) Priority Document No	:NA	2)Sudan Jha (Professor)
(32) Priority Date	:NA	3)Dr. Aprna Tripathi
(33) Name of priority country	:NA	4)A. Vijaya Lakshmi (Associate Professor)
(86) International Application No	:NA	5)Dr. Shubhangi Digamber Chikte (Professor)
Filing Date	:NA	6)Prof (Dr.) Baswaraj Gadgay (Regional Director)
(87) International Publication No	: NA	(72)Name of Inventor :
(61) Patent of Addition to Application Number	:NA	1)Dr. Anita. K. Patil (HOD)
Filing Date	:NA	2)Sudan Jha (Professor)
(62) Divisional to Application Number	:NA	3)Dr. Aprna Tripathi
Filing Date	:NA	4)A. Vijaya Lakshmi (Associate Professor)
		5)Dr. Shubhangi Digamber Chikte (Professor)
		6)Prof (Dr.) Baswaraj Gadgay (Regional Director)

(57) Abstract :

Using classified text and deep learning intelligent algorithms to identify risk and provide early warning. ABSTRACT Our Invention Using classified text and deep learning intelligent algorithms to identify highly risk and provide selected early warning is a Deep learning is used to identify specific, potential risks to an enterprise while such risks are still internal WI-FI, electronic communications. The invention is also to a system involves mining and using existing classifications of data to train more than one deep learning algorithms and then unique examining the internal electronic communications with the trained defined algorithm to generate a scored output that will enable enterprise personnel to be alerted to risks and take unique action in time to prevent the risks from resulting in harm to the enterprise or others. The invention is to a structured review of publications utilizing Deep Learning /machine learning methods to aid in engineering risk assessment and also a keyword search is performed to retrieve relevant articles from the databases of high Scopus and Engineering Village. The search results are filtered according to seven selection criteria and the filtering process resulted in the retrieval of one hundred and twenty-four relevant research content and the statistics based on different categories from the citation database is presented.

No. of Pages : 15 No. of Claims : 5

(12) PATENT APPLICATION PUBLICATION

(21) Application No.202121020748 A

(19) INDIA

(22) Date of filing of Application :07/05/2021

(43) Publication Date : 11/06/2021

(54) Title of the invention : MATHEMATICAL MODELLING AND SIMULATION USING REGRESSION ANALYSIS AND MACHINE LEARNING.

(51) International classification	:G06Q0050160000, G06Q0010060000, G05B0017020000, G06N0020000000, G06K0009620000	(71)Name of Applicant : 1)Jyoti Atul Dhanke Address of Applicant :(R) B-11, Swaranjali Society, Shivtirth Nagar Kothrud, Paud Road, Pune-411038, Maharashtra, India. (O) Bharati Vidyapeeth's College of Engineering Lavale, Pune Email: jyotidhanke@gmail.com Mobile:9850079005 Maharashtra India
(31) Priority Document No	:NA	2)Dr. Nilesh Mahajan
(32) Priority Date	:NA	3)Suvarna Ranjeet Jagtap
(33) Name of priority country	:NA	(72)Name of Inventor :
(86) International Application No	:NA	1)Jyoti Atul Dhanke
Filing Date	:NA	2)Dr. Nilesh Mahajan
(87) International Publication No	: NA	3)Suvarna Ranjeet Jagtap
(61) Patent of Addition to Application Number	:NA	
Filing Date	:NA	
(62) Divisional to Application Number	:NA	
Filing Date	:NA	

(57) Abstract :

ABSTRACT Our Invention Mathematical Modelling and Simulation using Regression Analysis and Machine Learning is a of property valuation literature indicated that the vast majority of researchers and complex academics in the field of real estate are focusing on Mass Appraisals rather than on the further development of the existing valuation methods. The variety of mathematical models used within the field of Machine Learning, which are applied to real estate valuations with high accuracy and also the other hand it appears that professional valuers do not use these sophisticated models during daily practice rather they operate using the traditional five methods. The Department of Lands and Surveys in Cyprus recently published the property values for taxation purposes which were calculated by applying a hybrid model based on the Cost approach with the use of regression analysis in order to quantify the specific parameters of each property. the service life of a particular item such as a component section of a building, are mathematically modeled to construct an initial lifecycle condition relationship as condition index (CI) v. time and to update the model, empirical data may be input at any time.

No. of Pages : 20 No. of Claims : 7

(12) PATENT APPLICATION PUBLICATION

(21) Application No.202121020868 A

(19) INDIA

(22) Date of filing of Application :07/05/2021

(43) Publication Date : 11/06/2021

(54) Title of the invention : AN UNDERCUT ANCHOR SYSTEM FOR MECHANICALLY MOUNTING, SUPPORTING, AND HOLDING DRY-CLAD STONES ON BUILDING STRUCTURES.

(51) International classification	:E04F0013080000, E04F0013140000, F24D0003140000, F16B0013080000, E04B0001410000	(71) Name of Applicant : 1)AUM ARTEMEC LLP Address of Applicant :T5, QURESHI COMPOUND, CHINCHOLI ROAD, OFF MUMBAI-AHMEDABAD HIGHWAY, NAIGAON, VASAI - 421208, MAHARASHTRA- INDIA. Maharashtra India
(31) Priority Document No	:NA	(72) Name of Inventor :
(32) Priority Date	:NA	1)SAILESH RAJNIKANT VORA
(33) Name of priority country	:NA	2)KENAR DILIP PATEL
(86) International Application No	:NA	
Filing Date	:NA	
(87) International Publication No	: NA	
(61) Patent of Addition to Application Number	:NA	
Filing Date	:NA	
(62) Divisional to Application Number	:NA	
Filing Date	:NA	

(57) Abstract :

ABSTRACT Title: AN UNDERCUT ANCHOR SYSTEM FOR MECHANICALLY MOUNTING, SUPPORTING AND HOLDING DRY-CLAD STONES ON BUILDING STRUCTURES An undercut anchor system (50) for mechanically mounting, supporting, and holding dry-clad stones on building structures, comprising: a back clip (10) fitted in undercut (Uc) in dry-clad stone (S) by undercut fastener (12); a transome (20) tightened on the wall or ceiling for mounting of dry-clad stone panel/slab (S) by back clip (10) fixed therein; the profiles of back clip (10) and transome (20) are configured mutually complimentary for precise alignment thereof and substantially free of expansion force and stresses developed therein for securely supporting the stone panel/slab (S) on the building structure. The back clip (10) and transome (20) are made from virgin or recycles extruded aluminium sections, preferably aluminium alloy 6063 T6. The dry-clad stone panel/slab (S) fitted with back clip (10) can be mounted on the transome (20) fixed in the wall or ceiling by fasteners (F) either directly or indirectly via subframe (F) with brackets (B). FIGURE 3.

No. of Pages : 34 No. of Claims : 10

(12) PATENT APPLICATION PUBLICATION

(21) Application No.202121020905 A

(19) INDIA

(22) Date of filing of Application :07/05/2021

(43) Publication Date : 11/06/2021

(54) Title of the invention : STRENGTH AND DURABILITY PROPERTIES OF CONCRETE USING GROUNDNUT SHELL AS FINE AGGREGATE

(51) International classification	:C04B0040000000, C04B0103300000, C04B0018240000, C04B0111270000, G01N0033380000	(71)Name of Applicant : 1)Mr. MILIND NANDKUMAR TELAVANE Address of Applicant :HEAD OF DEPARTMENT CIVIL ENGINEERING SHIVAJIRAO S. JONDHLE POLYTECHNIC OPP. ASANGAON RAILWAY STATION ASANGAON, SHAHAPUR, DIST.THANE , MAHARASHTRA 421601 Maharashtra India 2)Dr. M P SURESHKUMAR 3)Dr. ASHOK KUMAR KOSHARIYA 4)Mr. D. ZUNAITHUR RAHMAN 5)Dr. A.ARAVINDAN 6)Mr.S.GUNASEKAR 7)Dr.N.RAMESH 8)Dr.S.RAMESH 9)S.RAGUNATH 10)Dr. PERVAZ AHMAD GANIE
(31) Priority Document No	:NA	(72)Name of Inventor : 1)Mr. MILIND NANDKUMAR TELAVANE 2)Dr. M P SURESHKUMAR 3)Dr. ASHOK KUMAR KOSHARIYA 4)Mr. D. ZUNAITHUR RAHMAN 5)Dr. A.ARAVINDAN 6)Mr.S.GUNASEKAR 7)Dr.N.RAMESH 8)Dr.S.RAMESH 9)S.RAGUNATH 10)Dr. PERVAZ AHMAD GANIE
(32) Priority Date	:NA	
(33) Name of priority country	:NA	
(86) International Application No	:NA	
Filing Date	:NA	
(87) International Publication No	: NA	
(61) Patent of Addition to Application	:NA	
Number	:NA	
Filing Date	:NA	
(62) Divisional to Application Number	:NA	
Filing Date	:NA	

(57) Abstract :

ABSTRACT STRENGTH AND DURABILITY PROPERTIES OF CONCRETE USING GROUNDNUT SHELL AS FINE AGGREGATE Concrete plays a prominent role in the construction industry. In the present scenario, there is a shortage of this material. In the current situation, there is a deficiency of this material. So there is a need to discover choices to supplant it in the solid. To beat the present circumstance, many byproducts which are accessible uninhibitedly like paper squander, red mud, rice husk and plastic squanders can be utilized. Among these, groundnut shell is one of the great waste materials accessible from the oil business. It tends to be broadly utilized for the substitution of fine total. This test examination was done to assess the strength and sturdiness properties of concrete, in which fine total was supplanted with groundnut shell with various rates of 0% to 20% at time frame, were performed. Concrete was clustered by weight on receiving a proportion of 1:1.35:2.52 of M30 grade concrete with water concrete proportion of 0.4. Solid shapes of 150—150—150mm, chambers of 150—300mm were utilized. These shapes, chambers and bars were tried for 7, 14 and 28 days and contrasted and regular cement and it is tracked down that 5% of groundnut shell as fine total substitution delivered better outcomes looking at traditional cement.. Durability properties also show better results at 5% comparing to the conventional concrete. .

No. of Pages : 30 No. of Claims : 8

(54) Title of the invention : CONTACTLESS PALM VEIN BIOMETRIC AUTHENTICATION AND HEALTH MONITORING DEVICE.

<p>(51) International classification</p> <p>(31) Priority Document No</p> <p>(32) Priority Date</p> <p>(33) Name of priority country</p> <p>(86) International Application No Filing Date</p> <p>(87) International Publication No</p> <p>(61) Patent of Addition to Application Number Filing Date</p> <p>(62) Divisional to Application Number Filing Date</p>	<p>:G06K0009000000, A61B0005000000, A61B0005145500, G06F0021320000, A61B0005117000</p> <p>:NA</p> <p>:NA</p> <p>:NA</p> <p>:NA</p> <p>:NA</p> <p>:NA</p> <p>:NA</p> <p>:NA</p> <p>:NA</p> <p>:NA</p> <p>:NA</p>	<p>(71)Name of Applicant :</p> <p>1)Anil Kumar Gupta Address of Applicant :C-DAC Innovation Park, Sr. No.34/B/1, Panchavati, Pashan, Pune-411008, MH, India. E-mail: anilg@cdac.in Maharashtra India</p> <p>2)Dr. Rachna Somkunwar (Associate Professor)</p> <p>3)Amarjeet sharma</p> <p>4)Priyanka Kakade</p> <p>5)Aditya Gupta</p> <p>6)Harsh Gupta</p> <p>7)Pranjal Chinchwade</p> <p>(72)Name of Inventor :</p> <p>1)Anil Kumar Gupta</p> <p>2)Dr. Rachna Somkunwar (Associate Professor)</p> <p>3)Amarjeet sharma</p> <p>4)Priyanka Kakade</p> <p>5)Aditya Gupta</p> <p>6)Harsh Gupta</p> <p>7)Pranjal Chinchwade</p>
--	---	--

(57) Abstract :

ABSTRACT Today, the novel COVID-19 pandemic has taken a significant toll on countries worldwide and impacted the lives and well-being of people across nations. At the moment, many countries have taken measures, some of them stringent, to slow down the spread of SARS-CoV-2, the virus that causes COVID19. The globe is buzzing with uncertainty as there is no cure found for this problem yet. The only way to tackle the novel Coronavirus is taking precautions. People can become infected by touching infected objects or surfaces, then touching their eyes, nose or mouth. This is why it is vital to avoid unnecessary contact and incur hygienic habits. Technology and innovation can propose a helping hand in the fight against this pandemic crisis. One such device is the Contactless Palm Vein Biometric Authentication and COVID-19 Symptom Monitoring Device. The palm vein pattern is a unique biometric identity of human beings that is also a safe and reliable biometric authentication technique. The significant advantage of the multimodal device is that it is contactless, which makes it hygienic and highly helpful in times of pandemic, such as the novel Coronavirus pandemic. We have also added the functionality of pulse oximeter and temperature detection in the system. In this system, we are focusing on the process of designing a palm vein biometrics system, pulse oximeter and temperature detector in a step-by-step manner.

No. of Pages : 19 No. of Claims : 6

(12) PATENT APPLICATION PUBLICATION

(21) Application No.202121020907 A

(19) INDIA

(22) Date of filing of Application :08/05/2021

(43) Publication Date : 11/06/2021

(54) Title of the invention : POINT TO POINT REGRESSION ANALYSIS BIG DATA USING MACHINE LEARNING.

(51) International classification	:G06N0020000000, G06F0017180000, G05B0013020000, G06N0003080000, G06Q0050180000	(71)Name of Applicant : 1)Dr. R.N. Patil Address of Applicant :A/5, Shivam Enclave, Near Rathi C.N.G., Pune - 411046, Maharashtra, India. Email: rajendrakumar.patil@bharativedyapeeth.edu Mobile:9822431072 Maharashtra India 2)Dr. Baljeet Kaur 3)Sunilkumar Rajaram Patil 4)Satish Tukaram Rathod 5)Dr. Gurusharan Kaur 6)Dr. Namrata Tripathi 7)Amruta Mayur Pasarkar 8)Leena Bharat Chaudhari 9)Swati Gopal Gawhale 10)Suvarna Ranjeet Jagtap AN INDIAN NATIONAL 11)Jyoti Atul Dhanke
(31) Priority Document No	:NA	(72)Name of Inventor : 1)Dr. R.N. Patil 2)Dr. Baljeet Kaur 3)Sunilkumar Rajaram Patil 4)Satish Tukaram Rathod 5)Dr. Gurusharan Kaur 6)Dr. Namrata Tripathi 7)Amruta Mayur Pasarkar 8)Leena Bharat Chaudhari 9)Swati Gopal Gawhale 10)Suvarna Ranjeet Jagtap AN INDIAN NATIONAL 11)Jyoti Atul Dhanke
(32) Priority Date	:NA	
(33) Name of priority country	:NA	
(86) International Application No	:NA	
Filing Date	:NA	
(87) International Publication No	: NA	
(61) Patent of Addition to Application	:NA	
Number	:NA	
Filing Date	:NA	
(62) Divisional to Application Number	:NA	
Filing Date	:NA	

(57) Abstract :

ABSTRACT Our Invention point to point regression analysis big data processing using machine learning is a stepwise complex regression analysis-based global big data processing method. The rapid pace of technological advances creates many difficulties for R&D practitioners in analyzing emerging technologies. Patent information analysis is an effective tool in this situation. Conventional patent information analysis has focused on the extraction of vacant, promising, or core technologies and the monitoring of technological trends and also the method includes the following steps: 1: collecting data of factory operation parameters. 2: numbering the collected operation parameters. The invention is also using some of the collected operation defined parameters as dependent variables (tx, ty, tz), using other operation fixed parameters as independent variables and writing linear equations, wherein the parameters are in a linear relationship. The invention is a method and system for providing big data analytics framework for predictive and qualitative predictive analysis for social application developers data scientists and system unique engineers without having technology specific programming experience. The invented the framework contains adapters for the software engineers to configure the big data hub, wherein these hardware/software engineers can easily share, defined store, process and predict unique functionalities with the set of data scientists and user interface (UI) developers.

No. of Pages : 19 No. of Claims : 5

(54) Title of the invention : PLANT-IT

(51) International classification	:A01G0009020000, A47J0027210000, F24F0006000000, A47J0031200000, A01M0021040000	(71) Name of Applicant : 1)Mrs. Preethi Vijay Menon Address of Applicant :Kairali Bangla, 236, E Ward, Tarabai Park, Kolhapur-416003 Maharashtra India
(31) Priority Document No	:NA	(72) Name of Inventor : 1)Mrs. Preethi Vijay Menon
(32) Priority Date	:NA	
(33) Name of priority country	:NA	
(86) International Application No	:NA	
Filing Date	:NA	
(87) International Publication No	: NA	
(61) Patent of Addition to Application Number	:NA	
Filing Date	:NA	
(62) Divisional to Application Number	:NA	
Filing Date	:NA	

(57) Abstract :

A Planter device called as PLANT-IT 100, used for planting of indoor Plants comprising of a lid 101, a container called as main body 102 and a base for the main body 103. The Planter device called as PLANT-IT 100 which claimed in claim no 1, where in the lid 101 mounting on container called as main body 102, to cover the open top end of the Container used for pouring water into the container. The Planter device called as PLANT-IT 100 where in the container called as main body 102 placed on the base plate 103. Where in top end of the main body 102 is open ended for pouring water and bottom end of the container 102 is close ended and mounted on the base 103 to collect excess water. The Planter device called as PLANT-IT 100 where in the container called as main body 102 made by plurality of porous materials to achieve porosity for diffusion of water from the side wall of the container. The Planter device called as PLANT-IT 100 where in the outer side wall of the main body 102 made my micro structure 105 to hold seeds. The design of the serration permits anchoring of roots, permits proper aeration of the plants roots as well as provides a certain level of storage of water. The Planter device called as PLANT-IT 100 where in the process of making of main body 102 of the mixture of material used in such a right quantity and different steps which achieves adequate flow of water through the walls of the container, good capillary action to ensure adequate flow of water irrespective of the level of water in the container as well as provide adequate strength to the container to permit a certain level of mishandling during use and provide adequate strength to withstand the rigors of transportation during and after the manufacturing process till it is made available to the end user. The Planter device called as PLANT-IT 100 where in the container called as main body 102 on which epiphytic plants can be grown. The Planter device called as PLANT-IT 100 which is ecofriendly, safe for use and packaging is designed to withstand the rigors of normal handling during transportation to the end user. The process of making of device includes various steps viz. mixing, string, moulding, heating, firing and drying.

No. of Pages : 45 No. of Claims : 9

(12) PATENT APPLICATION PUBLICATION

(21) Application No.202121020999 A

(19) INDIA

(22) Date of filing of Application :10/05/2021

(43) Publication Date : 11/06/2021

(54) Title of the invention : PROCESS FOR IMPROVING MECHANICAL PROPERTIES OF IMPLEMENTS

(51) International classification	:B32B0021020000, G02F0001130000, B23P0015000000, C23C0008220000, A61C0008020000	(71)Name of Applicant : 1)SANDEEP HARISH DESHMUKH Address of Applicant :C 404, SUN SATELLITE, SINHGAD ROAD, ANAND NAGAR, PUNE, MAHARASHTRA, INDIA- 411051 Maharashtra India
(31) Priority Document No	:NA	2)DR. CHANDRASHEKHAR GOGTE
(32) Priority Date	:NA	(72)Name of Inventor :
(33) Name of priority country	:NA	1)SANDEEP HARISH DESHMUKH
(86) International Application No	:NA	2)DR. CHANDRASHEKHAR GOGTE
Filing Date	:NA	
(87) International Publication No	: NA	
(61) Patent of Addition to Application Number	:NA	
Filing Date	:NA	
(62) Divisional to Application Number	:NA	
Filing Date	:NA	

(57) Abstract :

ABSTRACT PROCESS FOR IMPROVING MECHANICAL PROPERTIES OF IMPLEMENTS A process for improving mechanical properties of implements 200 is disclosed. Accordingly, the preferred process for improving mechanical properties of implements 200 includes a first bionic surface development cycle 204, and a second bionic surface treatment cycle 208. The first cycle 204 includes steps 212 of cutting metal sheet, and then step 216 of rolling the cut sheet in accordance with the topology mimicked from the composite shape of culm leaf of a bamboo tree and buffalo hoof with a bionic surface pattern mimicked from a dung beetle head surface morphology to develop the bionic implement 100. The second step 208 of bionic treatment includes steps such as pre-heating 220, gas carburizing 224, case hardening 228, tempering 232 and coating 236 the bionic implement 100 for improving the mechanical properties of the bionic implement 100. FIG. 1 For Publication

No. of Pages : 20 No. of Claims : 5

(12) PATENT APPLICATION PUBLICATION

(21) Application No.202121021025 A

(19) INDIA

(22) Date of filing of Application :10/05/2021

(43) Publication Date : 11/06/2021

(54) Title of the invention : A MODIFIED BIODEGRADABLE ETHYLENE VINYL ACETATE FOAM AND A PROCESS FOR PREPARATION THEREOFF

(51) International classification	:C08J0009100000, C08K0005140000, A61K0033120000, C08K0009040000, A61K0008270000	(71) Name of Applicant : 1)Dr. Gokul Jaywant Jorwekar Address of Applicant :Pravara Institute of Medical Sciences (Deemed to be University) TM s Dr. Balasaheb Vikhe Patil Rural Medical College, Loni, Tal. Rahata, Dist: Ahmednagar, Maharashtra, India Maharashtra India
(31) Priority Document No	:NA	2)Pravara Institute of Medical Sciences
(32) Priority Date	:NA	3)Dr. Hemsing Kisan Rathod
(33) Name of priority country	:NA	4)Dr. Mohan Nagorao Pawar
(86) International Application No	:NA	(72) Name of Inventor :
Filing Date	:NA	1)Dr. Gokul Jaywant Jorwekar
(87) International Publication No	: NA	2)Dr. Hemsing Kisan Rathod
(61) Patent of Addition to Application Number	:NA	3)Dr. Mohan Nagorao Pawar
Filing Date	:NA	
(62) Divisional to Application Number	:NA	
Filing Date	:NA	

(57) Abstract :

Disclosed is a modified biodegradable EVA Foam comprising of i) modified EVA copolymer in an amount of 58.7wt% & polyhydroxybutyrate in an amount of 39.8 wt%, ii) azodicarbonamide in an amount of 5 wt%, iii) dicumyl peroxide in an amount of 1.5 wt%, iv) calcium carbonate in an amount of 4 wt%, v) talcum powder in an amount of 6 wt%, vi) stearic acid in amount of 1.5 wt%, vii) zinc oxide in an amount of 3 wt%. Also provided is a process for preparing the modified biodegradable EVA Foam. Figure 1.

No. of Pages : 21 No. of Claims : 5

(54) Title of the invention : A QUICK AND EFFECTIVE DISEASE PREDICTION AND TREATMENT SUGGESTION SYSTEM BASED ON MACHINE LEARNING

<p>(51) International classification</p> <p>(31) Priority Document No</p> <p>(32) Priority Date</p> <p>(33) Name of priority country</p> <p>(86) International Application No Filing Date</p> <p>(87) International Publication No</p> <p>(61) Patent of Addition to Application Number Filing Date</p> <p>(62) Divisional to Application Number Filing Date</p>	<p>:G16H0010600000, G06Q0050220000, G16H0050200000, G06F0016245700, G16H0010200000</p> <p>:NA</p> <p>:NA</p> <p>:NA</p> <p>:NA</p> <p>:NA</p> <p>:NA</p> <p>:NA</p> <p>:NA</p> <p>:NA</p>	<p>(71)Name of Applicant :</p> <p>1)Mr. Rahul Bhaurao Diwate Address of Applicant :Narshinha Saraswati Nagar,Near Rajiv Gandhi School,Gopal Nagar,Badnera Road,Amravati,444607. Email id : diwate.rahul@gmail.com Mobile No: 8087748493 Maharashtra India</p> <p>2)Mr. Vijayendra Sanjay Gaikwad</p> <p>3)Mrs. Mayura vishal shelke</p> <p>4)Ms.Savita</p> <p>5)Dr.Sandhya</p> <p>6)Dr. K. V. Bindu</p> <p>7)Ms. D. Nageswari</p> <p>8)Ms. G. Geethamahalakshmi</p> <p>9)Ms. SARITA SHANKARRAO CHAVHAN</p> <p>10)Dr. Archana Chandrakant Lomte</p> <p>11)Mrs.Varsha Rahul Dange</p> <p>12)Ms. B. Nagasri</p> <p>(72)Name of Inventor :</p> <p>1)Mr. Rahul Bhaurao Diwate</p> <p>2)Mr. Vijayendra Sanjay Gaikwad</p> <p>3)Mrs. Mayura vishal shelke</p> <p>4)Ms.Savita</p> <p>5)Dr.Sandhya</p> <p>6)Dr. K. V. Bindu</p> <p>7)Ms. D. Nageswari</p> <p>8)Ms. G. Geethamahalakshmi</p> <p>9)Ms. SARITA SHANKARRAO CHAVHAN</p> <p>10)Dr. Archana Chandrakant Lomte</p> <p>11)Mrs.Varsha Rahul Dange</p> <p>12)Ms. B. Nagasri</p>
--	---	---

(57) Abstract :

Medical data is one of the precise type of data that is pervasive today and is utilized for a diversity of formal and informal determinations. Formal uses of medical data include electronic medical records (EMR) which are composed every time a patient visits her or his doctor, analysis of clinical data from various studies, and so on. Informal examples of medical data can include that kept by an individual to track weight, number of cigarettes smoked, number of alcoholic drinks consumed per week, and so on. Whatever the source of the data, the data is stored for current and future use. The stored medical data is used for research and analysis purposes and is utilized to deliver healthcare to an individual, to track incidence of various diseases and medical conditions, as well as to track the spread of infections, diseases, etc. This invention made to identify one or more records consuming a specific phenotype receiving a plurality of first records, wherein each first record is associated with one or more of a plurality of phenotypes. Machine learning method is employed to identify records. Based on the detection of records, system predicts the diseases and suggest relevant treatments

No. of Pages : 14 No. of Claims : 3

(54) Title of the invention : BIOSENSOR FOR DETECTION OF ANALYTES IN A FLUID

(51) International classification	:G01N0033543000, B01L0003000000, C12Q0001000000, A61B0005000000, F28F0003020000	(71) Name of Applicant : 1)BALDWA, Mehul Address of Applicant :14 Shikshak Nagar, Aerodrome Road, Indore - 452005, Madhya Pradesh, India. Madhya Pradesh India
(31) Priority Document No	:NA	(72) Name of Inventor : 1)BALDWA, Mehul
(32) Priority Date	:NA	
(33) Name of priority country	:NA	
(86) International Application No	:NA	
Filing Date	:NA	
(87) International Publication No	: NA	
(61) Patent of Addition to Application Number	:NA	
Filing Date	:NA	
(62) Divisional to Application Number	:201821048976	
Filed on	:24/03/2019	

(57) Abstract :

The present disclosure relates to a biosensor 100 for detecting analytes present in the fluid. The biosensor 100 includes one or more plates (114-1 to 114-L) configured on a substrate 102 to form at least one channel (104-1 to 104-M) such that one or more containment chambers (106-1 to 106-N) are formed in the channels. The channels (104-1 to 104-M) are mechanically separated from each other by spacers (110), and the containment chambers (106-1 to 106-N) are fluidically separated from adjacent chamber by a discontinuity (108) such that the fluid flows between adjacent chambers only after an application of a predefined pressure on the plate. The multiple chambers (106-1 to 106-N) allows the fluid to undergo pre-processing using different set of reagents provided at different chambers, to mitigate effects of interferents and to efficiently distribute load of the reagents on the chambers (106-1 to 106-N). Further, some of containment chambers allows detection of analytes in the fluid using detection reagents.

No. of Pages : 50 No. of Claims : 6

(12) PATENT APPLICATION PUBLICATION

(21) Application No.202124015840 A

(19) INDIA

(22) Date of filing of Application :03/04/2021

(43) Publication Date : 11/06/2021

(54) Title of the invention : COMBINATION BROAD-SPECTRUM ANTIVIRAL NATURAL EXTRACT SUPPLEMENTS

(51) International classification	:A23L0021250000, A01N0025340000, A61K0031700000, A23K0010330000, A23L0002520000	(71) Name of Applicant : 1)Mark Edward Fenzl Address of Applicant :3734, Breezemont Drive, Sarasota, Florida, 34232, U.S.A. U.S.A.
(31) Priority Document No	:63/100,924	(72) Name of Inventor : 1)Mark Edward Fenzl
(32) Priority Date	:08/04/2020	
(33) Name of priority country	:U.S.A.	
(86) International Application No	:NA	
Filing Date	:NA	
(87) International Publication No	: NA	
(61) Patent of Addition to Application Number	:NA	
Filing Date	:NA	
(62) Divisional to Application Number	:NA	
Filing Date	:NA	

(57) Abstract :

The present technology may include combining different non-synthetic products to form a broad-spectrum antiviral supplement that inhibit or kill viruses. The antiviral supplement can be added to a shake, juice, or food to include antiviral properties. In one embodiment, the supplement may be configured to be admixed in the product. The product may include at least four ingredients selected from a first group, a second group, and a third group. In particular, the supplement may include at least four ingredients with two ingredients selected from the first group. Sweeteners including honey, artificial honey, molasses, or syrup combined with natural preservatives can also be used to provide broad-spectrum antiviral protection.

No. of Pages : 17 No. of Claims : 15

(12) PATENT APPLICATION PUBLICATION

(21) Application No.202041016711 A

(19) INDIA

(22) Date of filing of Application :17/04/2020

(43) Publication Date : 11/06/2021

(54) Title of the invention : A HEALTH ASSESSMENT SMART PHONE TOOL TOWARDS COMPREHENSIVE AND NON-INVASIVE EARLY STAGE DETECTION OF CORONAVIRUS INFECTION

(51) International classification	:A61B0005000000, A61B0005024000, A61B0005145500, A61B0005020500, A61B0005021000	(71) Name of Applicant : 1)Acculi Labs Private Limited Address of Applicant :31 Ground Floor, 3rd Cross Basappa Layout, Near BHEL Water Tank, Pattangere, Raja Rajeshwari Nagar, Bengaluru, Karnataka Karnataka India
(31) Priority Document No	:NA	(72) Name of Inventor :
(32) Priority Date	:NA	1)Rupam Das
(33) Name of priority country	:NA	
(86) International Application No	:NA	
Filing Date	:NA	
(87) International Publication No	: NA	
(61) Patent of Addition to Application Number	:NA	
Filing Date	:NA	
(62) Divisional to Application Number	:NA	
Filing Date	:NA	

(57) Abstract :

Abstract The present invention provides an efficient system and process for non-invasive early stage detection of Coronavirus Infection and monitoring thereof. A non-invasive and comprehensive around the clock detection of Coronavirus Infection by capturing arterial pulse from finger capillaries and using light reflection processing from smart phone camera to find major part of Coronavirus decision marker known as Peripheral Capillary Oxygen Saturation (spO2) • even from hypoxia patients. The present invention utilizes the principle of Photoplethysmography • (PPG), science of Diabetic Cardiovascular Autonomic Neuropathy • , science of Heart Rate Variability (HRV) • and glucose metabolism to estimate overall health status of the people. The present invention makes it easier for clinicians to detect the diseases at the early stage and helps the patients to monitor their progress. It offers a set of various functional biomarkers, which are correlated to various asymptomatic conditions related to various diseases. The overall efficiency of the present invention is 90.72%.

No. of Pages : 43 No. of Claims : 9

(12) PATENT APPLICATION PUBLICATION

(21) Application No.202041017359 A

(19) INDIA

(22) Date of filing of Application :22/04/2020

(43) Publication Date : 11/06/2021

(54) Title of the invention : AN HERBICIDE COMPOSITION AND A PROCESS OF PREPARATION THEREOF

(51) International classification	:B01J0029140000, C10M0125120000, A01N0057280000, C08F0004340000, A61K0031265000	(71) Name of Applicant : 1)M/S TAGROS CHEMICALS INDIA PVT. LTD Address of Applicant :JHAVER CENTRE, RAJAH ANNAMALAI BUILDING, 4TH FLOOR, 72 MARSHALLS ROAD, EGMORE, CHENNAI 600008, India Tamil Nadu India
(31) Priority Document No	:NA	(72) Name of Inventor :
(32) Priority Date	:NA	1)SRIKRISHNAN, Rajaiah
(33) Name of priority country	:NA	2)SREEDHAR, Chemuturi
(86) International Application No	:NA	3)BOSE, Abhijit
Filing Date	:NA	4)PICHUMANI, Narayanamoorthy
(87) International Publication No	: NA	
(61) Patent of Addition to Application Number:	NA	
Filing Date	:NA	
(62) Divisional to Application Number	:NA	
Filing Date	:NA	

(57) Abstract :
AS ATTACHED

No. of Pages : 140 No. of Claims : 20

(12) PATENT APPLICATION PUBLICATION

(21) Application No.202041024382 A

(19) INDIA

(22) Date of filing of Application :10/06/2020

(43) Publication Date : 11/06/2021

(54) Title of the invention : AN ALL-TERRAIN UTILITY VEHICLE AND METHODS THEREOF

(51) International classification	:G05D0001020000, A01B0069000000, B60C0001000000, G06F0001240000, B60F0003000000	(71) Name of Applicant : 1)Mahindra & Mahindra Limited Address of Applicant :Mahindra Research Valley, Mahindra World City, Plot No: 41/1, Anjur P.O. , Chengalpattu, Kanchipuram District, Tamilnadu 603004 India Tamil Nadu India
(31) Priority Document No	:NA	(72) Name of Inventor :
(32) Priority Date	:NA	1)VARADA PRASHANT RAO
(33) Name of priority country	:NA	2)SHANKAR VENUGOPAL
(86) International Application No	:NA	3)SAYANTAN MUKHERJEE
Filing Date	:NA	4)RAM MOHAN SITARAMAN
(87) International Publication No	: NA	5)SIDDHARTHA RAJ
(61) Patent of Addition to Application Number	:NA	6)Ms. SNIGDHARANI EPARI
Filing Date	:NA	7)DEEPAK SAINI
(62) Divisional to Application Number	:NA	8)Ms. ABHISHANSHA GAUTAM
Filing Date	:NA	9)HARSH PATEL
		10)SRINIVAS KANNAN

(57) Abstract :

AN ALL-TERRAIN UTILITY VEHICLE AND METHODS THEREOF The disclosures herein generally relate to a vehicle and more particularly, to an all-terrain utility vehicle which can perform multiple operations, in varied terrain and soil conditions, with precision and guidance. An all-terrain utility vehicle (10) mainly includes wheel track and wheel base adjusting system (100), a height adjusting system (200), a plurality of vertical axle assemblies (300), a steering system (400), an implement position adjusting system (700), a master controller unit (802) and a plurality of wheel drive motors (1200). All the vehicle functions being controlled and guided with the help of an electronic master control module which enables optional manual, remote and autonomous operations. The electronic master control module utilizes externally acquired location data and digital maps with soil and plant information for enabling precision field operations. Fig. 1

No. of Pages : 108 No. of Claims : 38

(12) PATENT APPLICATION PUBLICATION

(21) Application No.202041026785 A

(19) INDIA

(22) Date of filing of Application :24/06/2020

(43) Publication Date : 11/06/2021

(54) Title of the invention : A PORTABLE OXYGEN GENERATOR SYSTEM

(51) International classification	:A61M0016100000, A62B0021000000, A61M0016000000, A62B0007020000, A62B0007080000	(71) Name of Applicant : 1)O2-Matic Products Private Limited Address of Applicant :B450 Mahaveer Tuscan Apartment, Basavanagar Road, Bangalore 560048 Karnataka India
(31) Priority Document No	:NA	(72) Name of Inventor :
(32) Priority Date	:NA	1)John Paul Thambusami Joy Sachidanadam
(33) Name of priority country	:NA	
(86) International Application No	:NA	
Filing Date	:NA	
(87) International Publication No	: NA	
(61) Patent of Addition to Application Number	:NA	
Filing Date	:NA	
(62) Divisional to Application Number	:NA	
Filing Date	:NA	

(57) Abstract :

A PORTABLE OXYGEN GENERATOR SYSTEM ABSTRACT A cartridge system (20) comprising a container (30) and at least four cartridges (70) for generating oxygen, a compressor (190) for compressing the generated oxygen, at least one storage tank (200) configured to store the compressed oxygen received from the compressor (190), an oxygen pressure regulator (210) enabling a uniform flow of oxygen at pre-defined oxygen pressure, an oxygen flow control knob (240) regulating flow ratio of the oxygen being supplied to the patient in an instant, a humidifier means (230) imparting humidity to the oxygen being supplied to a patient, and a display unit displaying a set of information associated with the system and communicatively coupled to the portable oxygen generator system (10) via wireless network. The cartridge(s) may be triggered in a plurality of ways to maintain a continuous outflow of generated oxygen for a longer duration. Further, the operation of the system may be monitored or controlled wirelessly from a distant location. . FIG. 4

No. of Pages : 32 No. of Claims : 17

(12) PATENT APPLICATION PUBLICATION

(21) Application No.202041029619 A

(19) INDIA

(22) Date of filing of Application :13/07/2020

(43) Publication Date : 11/06/2021

(54) Title of the invention : AUTOMATED BELT WRAPPING MACHINE AND METHOD THEREOF

(51) International classification	:D06F0033000000, H01B0013260000, B65B0011020000, H01B0007295000, H01B0013100000	(71) Name of Applicant : 1)J.K. FENNER (INDIA) LIMITED Address of Applicant :480, Anna Salai, 5th Floor, Khivraj Complex Phase II, Nandanam, Chennai Tamil Nadu India
(31) Priority Document No	:NA	(72) Name of Inventor :
(32) Priority Date	:NA	1)M. NAGARAJAN
(33) Name of priority country	:NA	2)N. KARTHIK
(86) International Application No	:NA	
Filing Date	:NA	
(87) International Publication No	: NA	
(61) Patent of Addition to Application Number:	:NA	
Filing Date	:NA	
(62) Divisional to Application Number	:NA	
Filing Date	:NA	

(57) Abstract :

The present invention generally relates to the field of machine automation. The present invention particularly relates to automated wrapping machine. The automated belt wrapping machine comprises of a vertical loader unit, a wrapping unit, a jacket feeder unit, a belt unloading unit, two or more servomotors [2.6], one or more sensors, one or more actuators, operator / user interface and one or more pneumatic cylinders [11]. Further the present invention relates to a method of working of the automated wrapping machine. Advantageously, the present invention can be utilized to wrap a fabric around the belt with automated overlap control. FIGURE 3.

No. of Pages : 46 No. of Claims : 23

(12) PATENT APPLICATION PUBLICATION

(21) Application No.202041030027 A

(19) INDIA

(22) Date of filing of Application :15/07/2020

(43) Publication Date : 11/06/2021

(54) Title of the invention : SECURITY FEATURED SOFTWARE DEFINED UNMANNED WIRELESS SENSING NODE

(51) International classification	:H04W0084180000, G01V0001180000, H02J0007320000, G08B0013000000, A45C0013180000	(71) Name of Applicant : 1)Dr. P. MOHANA PRIYA Address of Applicant :No. 2, Kannagi Street, Muthamiz Nagar, Eswari Nagar, Medical College Road, Near Amirtha Ladies Hostel, Thanjavur Tamil Nadu India
(31) Priority Document No	:NA	(72) Name of Inventor :
(32) Priority Date	:NA	1)Dr. P. MOHANA PRIYA
(33) Name of priority country	:NA	
(86) International Application No	:NA	
Filing Date	:NA	
(87) International Publication No	: NA	
(61) Patent of Addition to Application Number	:NA	
Filing Date	:NA	
(62) Divisional to Application Number	:NA	
Filing Date	:NA	

(57) Abstract :

The present invention relates to a situation aware software defined unmanned wireless sensor nodes to be deployed sensitive installations where security considered as primary priority, more particularly the said sensor nodes to be embodied with an intelligent cryptography technique to secure the data in real time, comprises a plurality of wireless sensor node [120], said wireless sensor node, comprises a functional microcontroller [100] built-in with a communication module [109]; a serial flash memory [110]; and a battery unit [111]. Said wireless sensor node [120] functionally provisioned to have a data-control and a control-application plane referred as open-flow protocol interface that differentiates the software basis of cryptography algorithm and data related, thus ensures the optimum utilization of memory space and also functional efficiency of the microcontroller with minimum complexity involved.
FIGURE 1

No. of Pages : 19 No. of Claims : 8

(12) PATENT APPLICATION PUBLICATION

(21) Application No.202041030593 A

(19) INDIA

(22) Date of filing of Application :17/07/2020

(43) Publication Date : 11/06/2021

(54) Title of the invention : SYSTEM FOR MANUFACTURING OF POWER TRANSMISSION BELT AND METHOD THEREOF

(51) International classification	:H01L0029660000, F16G0005200000, F16G0001100000, H02J0005000000, F16G0001280000	(71) Name of Applicant : 1)J.K. FENNER (INDIA) LIMITED Address of Applicant :480, Anna Salai, 5th Floor, Khivraj Complex Phase II, Nandanam, Chennai Tamil Nadu India
(31) Priority Document No	:NA	(72) Name of Inventor :
(32) Priority Date	:NA	1)P.G.S. SELVAN DINESH DAVIDSON
(33) Name of priority country	:NA	2)M. NAGARAJAN
(86) International Application No	:NA	3)M. PANDY
Filing Date	:NA	4)G. RAJASEKAR
(87) International Publication No	: NA	5)A. DAVID MELCHI MESHACH
(61) Patent of Addition to Application Number	:NA	
Filing Date	:NA	
(62) Divisional to Application Number	:NA	
Filing Date	:NA	

(57) Abstract :

The present invention relates to power transmission belt. More particularly, the present invention relates to a system/equipment for manufacturing of power transmission belt particularly endless wrapped V belt. The system for manufacturing of wrapped power transmission belt comprises of component assembly, fabric frictioning assembly, and curing machine assembly. The consolidated system for manufacturing of the wrapped power transmission belt comprises of an extruder [150], a take-away conveyor [151], a dancing arm [152], geometric inspection [153], a coolant tank [154], an air blower [155], online weigher [156], a paint marking [157], a dancing arm [158], a haul-off unit [159], a conveyor [160], a swing conveyor [161] and a drum building station [162]. Further the present invention relates to a method of manufacturing of power transmission belt. Advantageously the present invention relates to a single piece flow production method from rubber compound stage to finished product with machine automation. FIGURE 17.

No. of Pages : 78 No. of Claims : 42

(12) PATENT APPLICATION PUBLICATION

(21) Application No.202041040957 A

(19) INDIA

(22) Date of filing of Application :22/09/2020

(43) Publication Date : 11/06/2021

(54) Title of the invention : SYSTEM AND METHOD FOR DATA SECURITY AND SECURED AUTHENTICATION

(51) International classification	:G06Q0020400000, H04L0029060000, G06N0020000000, G06F0016951000, G06F0021620000	(71) Name of Applicant : 1)CHETANA KOULAGI Address of Applicant :C12, AJMERA VILLOWS, NEELADRI ROAD, ELECTRONIC CITY PHASE 1, BANGALORE, 560100, KARNATAKA, INDIA Karnataka India
(31) Priority Document No	:NA	(72) Name of Inventor :
(32) Priority Date	:NA	1)CHETANA KOULAGI
(33) Name of priority country	:NA	2)NIKSHEP GRAMPUROHIT
(86) International Application No	:NA	3)SATISH GRAMPUROHIT
Filing Date	:NA	4)PRANJAL GRAMPUROHIT
(87) International Publication No	: NA	
(61) Patent of Addition to Application Number	:NA	
Filing Date	:NA	
(62) Divisional to Application Number	:NA	
Filing Date	:NA	

(57) Abstract :

A system for data security and secured authentication is provided. The system includes a visual media receiving subsystem which receives multiple visual media. The system also includes an entity detection subsystem which detects for presence of entities. The system also includes an entity distinguishing subsystem which distinguishes the entities for being one of an image capturing lens or user(s) and counts the entities. The system also includes a learning subsystem which generates and updates a server with the training model in real-time. The system also includes a user authentication subsystem which authenticates the authorized user. The system also includes an event triggering subsystem which triggers an event on the authorized user device upon occurrence of one of the count of the user(s) is greater than unity, the entities include the image capturing lens, the authentication result includes a negative authentication result, identification of fraudulent activity, or a combination thereof. FIG. 1

No. of Pages : 28 No. of Claims : 10

(12) PATENT APPLICATION PUBLICATION

(21) Application No.202141007423 A

(19) INDIA

(22) Date of filing of Application :22/02/2021

(43) Publication Date : 11/06/2021

(54) Title of the invention : DIGITAL TWINS USING CONVOLUTIONAL NEURAL NETWORKS TO EMULATE DETAILED CONDITIONS WITHIN REPRESENTED PHYSICAL PROCESSES

(51) International classification	:G06N0003040000, G06F0111100000, G06N0003020000, G06F0017130000, G01N0033000000	(71) Name of Applicant : 1)Ecole Centrale School of Engineering, Mahindra University Address of Applicant :Ecole Centrale School of Engineering, Mahindra University , Survey No 62/1A, Bahadurpally, Hyderabad- 500043, Telangana, India Telangana India
(31) Priority Document No	:NA	(72) Name of Inventor :
(32) Priority Date	:NA	1)Dr. Arya K. Bhattacharya
(33) Name of priority country	:NA	
(86) International Application No	:NA	
Filing Date	:NA	
(87) International Publication No	: NA	
(61) Patent of Addition to Application Number	:NA	
Filing Date	:NA	
(62) Divisional to Application Number	:NA	
Filing Date	:NA	

(57) Abstract :

ABSTRACT OF THE INVENTION DIGITAL TWINS USING CONVOLUTIONAL NEURAL NETWORKS TO EMULATE DETAILED CONDITIONS WITHIN REPRESENTED PHYSICAL PROCESSES Most sub-processes in industry, transportation, etc. are describable by approximate versions of the complete sets of partial differential equations that govern their underlying physics, hence their solution in real time will enable significantly superior and precise monitoring, control and prognostics of running processes. Arrays of sensors installed at the physical boundaries of process domains can provide the crucial inputs to ANN-like architectures that can transform these isolated values into detailed field conditions. Provided these ANN-like mechanisms can exhibit the following properties that they respond in process-real-time, their solutions are nearly as accurate as the offline numerical simulations of the governing equations from whose data they learn the functional relationships, and importantly, they can map a few score inputs into around two-orders-of-magnitude more number of outputs. This invention presents Convolutional-NN-like architectures based primarily on transpose convolutions and other design features that satisfy all the three crucial properties. Efficacy is demonstrated on two different, complex, application domains of the reduced Navier-Stokes equations. The invention can be applied to any operating process or dynamical system, to create a digital mockup that runs in parallel at a remote control location taking online sensor inputs and providing real time, accurate, comprehensive view of the internal dynamics of the system. Figure of Abstract: Fig. 1

No. of Pages : 32 No. of Claims : 8

(12) PATENT APPLICATION PUBLICATION

(21) Application No.202141014505 A

(19) INDIA

(22) Date of filing of Application :30/03/2021

(43) Publication Date : 11/06/2021

(54) Title of the invention : INTEGRATED HIGH PRESSURE WATER JET CLEANING APPARATUS IN AUTOMOBILE

(51) International classification	:B60S0003040000, B08B0003020000, C25B0009100000, B08B0009032000, G06Q0090000000	(71)Name of Applicant : 1)Dr. Nagaswarupa H P Address of Applicant :Associate Professor, Department of Studies in Chemistry, Shivagangothri, Davangere University, Davangere -577007 Karnataka India 2)Dr. Praveen Kumar M V 3)Dr. Rudresh M
(31) Priority Document No	:NA	(72)Name of Inventor : 1)Dr. Nagaswarupa H P 2)Dr. Praveen Kumar M V 3)Dr. Rudresh M
(32) Priority Date	:NA	4)Mr. Manjunath T S 5)Dr. Veeresh Kumar G B 6)Dr. C S P Rao 7)Mr. Sevan Chandra M V 8)Mrs. Poornima J G
(33) Name of priority country	:NA	
(86) International Application No	:PCT//	
Filing Date	:01/01/1900	
(87) International Publication No	: NA	
(61) Patent of Addition to Application Number	:NA	
Filing Date	:NA	
(62) Divisional to Application Number	:NA	
Filing Date	:NA	

(57) Abstract :

The present invention relates to an apparatus used for the high pressure water jet cleaning apparatus used to clean / wash the vehicle. In general, proposed product is closest to the known product which is a standalone fixed or portable type. High pressure car washer which needs electrical power to operate and has to be carried separately. This standalone apparatus which costs huge money and to be connected to external electric source to run the apparatus which is a tedious work and costly too. Current invention focuses on the apparatus which is low cost and compact in nature and which is integrated with motor vehicle or motor boat and does not need any external source of electric power and can be connected directly to the engine drive to build the high pressure water jet for cleaning purpose of vehicles including 2W, 3W 4W, truck, buses and marine application. The proposed product is compact and has lower cost of ownership and ease of use as there is no need to carry the water jet washer separately. Apparatus can be used as integral to vehicle engine and does not need any external source of electric power. The proposed concept is readily available with low cost components and is easy to build and install. Hence the total cost of the product can be reduced.

No. of Pages : 8 No. of Claims : 3

(54) Title of the invention : LOW COST SUNLIGHT HARVESTING SYTEM FOR RURAL INDOOR LIGHTING

(51) International classification	:F21S0009030000, F21S0011000000, F21S0019000000, A01N0043160000, F03C0001000000	(71) Name of Applicant : 1)Dr. Praveen Kumar M V Address of Applicant :N0.182, 10th cross Health layout, Bangalore-560091 Karnataka India 2)Dr. Rudresh M 3)Dr. Nagaswarupa H P
(31) Priority Document No	:NA	(72) Name of Inventor : 1)Dr. Rudresh M 2)Dr. Veeresh Kumar G B 3)Dr. Seenappa 4)Dr. Praveen Kumar M V 5)Mr. Manjunath T S 6)Mrs. Poornima J G 7)Mr. Sevan Chandra M V 8)Dr. Nagaswarupa H P
(32) Priority Date	:NA	
(33) Name of priority country	:NA	
(86) International Application No	:PCT///	
Filing Date	:01/01/1900	
(87) International Publication No	: NA	
(61) Patent of Addition to Application Number	:NA	
Filing Date	:NA	
(62) Divisional to Application Number	:NA	
Filing Date	:NA	

(57) Abstract :

The present invention relates to an low cost sunlight harvesting system for rural indoor lighting. India is facing a severe shortage of electricity. Key cities are down with 2-6 hour power cuts while rural India is facing the brunt of this outage with almost 10 hours of daily power cuts. Many would admit the obvious reason for this outage, amongst others, as the reduced availability of coal to generate electricity. 60% of India's electricity comes from coal. With growing uncertainty around the availability and cost of this fossil fuel, a number of power plants are having to run on low capacity and therefore the nation is power deprived. As long as India continues to depend on coal, we will continue to face more and more power outages across the country which will eventually disrupt our economy, our transport, our health services and slow down overall production. Coal, gas and oil will not be the three kinds of the energy world for ever, moreover Fossil fuels are dirty and the prices of the fossil fuels steeply increasing, so renewable are expected to play a key role to overcome the crisis of electricity. There is a high demand for electricity around the world and everyone is looking for renewable source for light. We have so many ways to generate the electricity like, tidal, geo thermal, nuclear, thermal, hydro and solar and among that solar is the highly renewable source what is available in the earth and India is sun's most favored nation. In India renewable energy has particular relevance in remote and rural areas where there are around 289 million people who don't have an access to reliable sources of energy for light. Owing to this, Design and development of 24x7 lighting system has been arrived. In this system, the solar energy will be directly used to lighten the houses during daytime & solar powered lighting system will be used during night, This in turn helps to reduce the consumption of electrical energy and dependency on non renewable energy sources. The invention aimed at achieving the following objectives: 1.To develop a cost effective lighting system for rural 2.To utilize sunlight energy for lighting the house during day and night 3.To develop a reliable and environmental friendly product

No. of Pages : 11 No. of Claims : 3

(12) PATENT APPLICATION PUBLICATION

(21) Application No.202141014597 A

(19) INDIA

(22) Date of filing of Application :30/03/2021

(43) Publication Date : 11/06/2021

(54) Title of the invention : BAITING SCAM ATTACK DETECTION USING TWO WAY AUTHENTICATION BY ECC APPROACH

(51) International classification	:H04L0029060000, H04L0012580000, H04M0015100000, G06F0021550000, A01K0091180000	(71)Name of Applicant : 1)Dr.J.JEAN JUSTUS Address of Applicant :Associate Professor Department of Computer Science & Engineering St. Joseph's College of Engineering Old Mamallapuram Road Chennai Tamilnadu India 600119 Tamil Nadu India 2)Dr. UDHAYA SANKAR S.M 3)Dr.V.GOWRI 4)Dr. GANESAN R. 5)Dr. S. AHAMED ALI 6)Dr. R.THIAAGARAJAN 7)Dr. S. ARUN
(31) Priority Document No	:NA	(72)Name of Inventor : 1)Dr.J.JEAN JUSTUS 2)Dr. UDHAYA SANKAR S.M 3)Dr.V.GOWRI 4)Dr. GANESAN R. 5)Dr. S. AHAMED ALI 6)Dr. R.THIAAGARAJAN 7)Dr. S. ARUN
(32) Priority Date	:NA	
(33) Name of priority country	:NA	
(86) International Application No	:PCT//	
Filing Date	:01/01/1900	
(87) International Publication No	: NA	
(61) Patent of Addition to Application Number	:NA	
Filing Date	:NA	
(62) Divisional to Application Number	:NA	
Filing Date	:NA	

(57) Abstract :

To protect over the client side, the reliable way of approach has been initiated to detect over the unsolicited email messages and illegitimate web pages. To identify whether the web pages is legitimate and authenticated, the two way approach has been initiated. ECC approach generates and verifies over the key digitalized signature. Spam website has to be identified using two way of authentication (i.e. Host based authentication and web based authentication). Acknowledgement has to be given for every packet to analyze by providing personal protection to all Internet users whether the browser as any plug in. The website can be checked whether it is baiting scam target or genuine one by processing the two tier mechanism. Since, the security aspects gets increased the baiting scam attack over the messages such as email messages; SMS and MMS can be reduced.

No. of Pages : 14 No. of Claims : 8

(12) PATENT APPLICATION PUBLICATION

(21) Application No.202141015257 A

(19) INDIA

(22) Date of filing of Application :31/03/2021

(43) Publication Date : 11/06/2021

(54) Title of the invention : MACHINE LEARNING BASED IDENTIFICATION OF TUMOR USING SIANLM AND MFCM ALGORITHM FROM MRI BRAIN IMAGES

(51) International classification	:A61B0005000000, G06T0007000000, G06K0009620000, G16H0050200000, G01R0033560000	(71) Name of Applicant : 1)Dr SALADI SARITHA Address of Applicant :Associate Professor, Dept of ECE, Geethanjali College of Engineering and Technology, Hyderabad, Telangana-501301, India Telangana India
(31) Priority Document No	:NA	2)Dr SPANDANA PARAMKUSHAM
(32) Priority Date	:NA	3)Dr S VALLI SREE
(33) Name of priority country	:NA	(72) Name of Inventor :
(86) International Application No	:PCT//	1)Dr SALADI SARITHA
Filing Date	:01/01/1900	2)Dr SPANDANA PARAMKUSHAM
(87) International Publication No	: NA	3)Dr S VALLI SREE
(61) Patent of Addition to Application Number	:NA	
Filing Date	:NA	
(62) Divisional to Application Number	:NA	
Filing Date	:NA	

(57) Abstract :

This invention is pertaining to detection of brain tumor provided MRI brain images as input. It realizes a framework with desired mechanisms and algorithms for automatic detection of brain tumors. Provided MRI images of brain as input, the framework has different algorithms to arrive at the tumor detection decision with higher level of accuracy. This invention has an improved FCM for soft clustering of MRI image data in order to identify tumors, with the help of feature extraction techniques to improve the performance by reducing computational and time complexity significantly. This invention is also equipped with a multi-model approach towards noise removal as part of SIANLM algorithm. Feature extraction with both PCA and DWT improves tumor detection accuracy. It provides solution to the problem of brain tumor detection with an automated approach that has utility and can be used in Clinical Decision Support Systems (CDSSs) in the real word to save the resources, energy and time of both patients and the clinicians. It benefits to many stakeholders such as patients, doctors, healthcare professionals, healthcare units, researchers and academia.

No. of Pages : 15 No. of Claims : 7

(54) Title of the invention : SOLAR POWER ASSISTED VENTILATED FACE MASK WITH Y BONE SEPERATOR

<p>(51) International classification</p> <p>(31) Priority Document No</p> <p>(32) Priority Date</p> <p>(33) Name of priority country</p> <p>(86) International Application No Filing Date</p> <p>(87) International Publication No</p> <p>(61) Patent of Addition to Application Number Filing Date</p> <p>(62) Divisional to Application Number Filing Date</p>	<p>:A41D0013110000, A62B0023020000, A47C0007020000, A62B0009060000, A61K0009480000</p> <p>:NA</p> <p>:NA</p> <p>:NA</p> <p>:NA</p> <p>:NA</p> <p>: NA</p> <p>:NA</p> <p>:NA</p> <p>:NA</p> <p>:NA</p>	<p>(71)Name of Applicant :</p> <p>1) J E MOSHE DAYAN Address of Applicant :57, DEVA SAHAYA NAGAR S.R. MILLS ROAD, DINDIGUL, TAMILNADU, INDIA, 624003 Tamil Nadu India</p> <p>2)SUGANYA SRINIVASAN</p> <p>3)ARUN PRASAD DEENADAYALAN</p> <p>4)F X EDWIN DEEPAK</p> <p>5)NIVETHA MARTIN</p> <p>6)SHOWRILU KONDAVEETI</p> <p>7)J. JOTHAM ROHIT</p> <p>8)T ESTHER</p> <p>(72)Name of Inventor :</p> <p>1) J E MOSHE DAYAN</p> <p>2)SUGANYA SRINIVASAN</p> <p>3)ARUN PRASAD DEENADAYALAN</p> <p>4)F X EDWIN DEEPAK</p> <p>5)NIVETHA MARTIN</p> <p>6)SHOWRILU KONDAVEETI</p> <p>7)J. JOTHAM ROHIT</p> <p>8)T ESTHER</p>
--	---	---

(57) Abstract :

In the recent days, wearing masks is an extremely important habit that every one of us should be applying since this simple step could significantly reduce the risk of transmission of corona virus. The major problem identified on wearing a 3 or more layered mask, over a long period of time is suffocation, and that it creeps up especially when the user is continuous in physical work. The reason for the above statement is because one will re-inhale the exhaled air on wearing a highly protective multi layered mask and hence the continuous usage will result in suffocation and may also result in losing consciousness as the exhaled air, when re-enters the nostrils affects the respiratory system. Hence the present invention provides a simple solution to the existing problems that are available in wearing the face masks at the same time it also ensures absolute safety to the user in providing optimum safety in preventing microorganisms are bacteria and viruses entering and it primarily has all the multi layered protection like any other high end masks available in the market. The whole system is contemporary and works as an independent module and a user friendly equipment with all safety features ensured.

No. of Pages : 31 No. of Claims : 10

(12) PATENT APPLICATION PUBLICATION

(21) Application No.202141016712 A

(19) INDIA

(22) Date of filing of Application :09/04/2021

(43) Publication Date : 11/06/2021

(54) Title of the invention : SMART JACKET TO MAINTAIN SOCIAL DISTANCING

(51) International classification	:G06F0021560000, G06Q0050220000, G08B0021020000, A45C0013100000, C02F0101100000	(71)Name of Applicant : 1)Dr. Rashmi Priyadarshini B K Address of Applicant :School of ECE, REVA University, Rukmini Knowledge Park, Kanigenahalli, Yelahanka, Bangalore, Karnataka, India 560064. Karnataka India
(31) Priority Document No	:NA	2)M THIRUMAL ANAND
(32) Priority Date	:NA	3)KAUSHAL KALING
(33) Name of priority country	:NA	4)KEERTHI H V
(86) International Application No	:NA	5)MADHU CHANDRIKA B
Filing Date	:NA	(72)Name of Inventor :
(87) International Publication No	: NA	1)Dr. Rashmi Priyadarshini B K
(61) Patent of Addition to Application Number:	:NA	2)M THIRUMAL ANAND
Filing Date	:NA	3)KAUSHAL KALING
(62) Divisional to Application Number	:NA	4)KEERTHI H V
Filing Date	:NA	5)MADHU CHANDRIKA B

(57) Abstract :

The Covid-19 pandemic is tragedy that this generation is faced with, there isn't a stop for this, deadly virus just yet. That doesn't mean we fall victim to it, although travelling outside cannot be avoided completely we can take measures to prevent acquiring the virus. The World Health Organization recommends frequent sanitization of places of contact, temperature checks at regular intervals and most important of all Social Distancing i.e. to maintain at least 6-feet distance from surrounding population. This project is to aid this norm by creating, awareness to the user if a person doesn't follow social distancing protocol around said user and possibly stop the spread.

No. of Pages : 8 No. of Claims : 6

(54) Title of the invention : A METHOD FOR EFFICIENT AND FASTER MACHINE LEARNING TECHNIQUE

<p>(51) International classification</p> <p>(31) Priority Document No</p> <p>(32) Priority Date</p> <p>(33) Name of priority country</p> <p>(86) International Application No Filing Date</p> <p>(87) International Publication No</p> <p>(61) Patent of Addition to Application Number Filing Date</p> <p>(62) Divisional to Application Number Filing Date</p>	<p>:G06N0020000000, G06F0030332300, G06F0016350000, G06K0009620000, A61B0017000000</p> <p>:NA</p> <p>:NA</p> <p>:NA</p> <p>:PCT// :01/01/1900</p> <p>: NA</p> <p>:NA</p> <p>:NA</p> <p>:NA</p>	<p>(71)Name of Applicant : 1)S GOKULAKRISHNAN Address of Applicant :S/o. N SIVANANDHAM, DEPARTMENT OF COMPUTER SCIENCE AND ENGINEERING, SRI CHANDRASEKHARENDRA SARASWATHI VISWA MAHAVIDYALAYA [SCSVMV DEEMED TO BE UNIVERSITY], ENATHUR, KANCHIPURAM 631561, TAMIL NADU, INDIA. Tamil Nadu India</p> <p>2)A R GURU GOKUL 3)N DEVI 4)P LEELA RANI 5)Dr. S SATHYA 6)Dr. C SUNITHA RAM 7)Dr. N KUMARAN 8)J SHYAM MOHAN 9)E PADMA</p> <p>(72)Name of Inventor : 1)S GOKULAKRISHNAN 2)A R GURU GOKUL 3)N DEVI 4)P LEELA RANI 5)Dr. S SATHYA 6)Dr. C SUNITHA RAM 7)Dr. N KUMARAN 8)J SHYAM MOHAN 9)E PADMA</p>
--	--	--

(57) Abstract :

The present invention depicts simple and efficient method for interactively learning non-binary concepts in the learning from random counter-examples (LRC) model. Here, learning takes place from random counter-examples that the learner receives in response to their proper equivalence queries, and the learning time is the number of counter-examples needed by the learner to identify the target concept. Such learning is particularly suited for online ranking, classification, clustering, etc., where machine learning models must be used before they are fully trained.

No. of Pages : 12 No. of Claims : 2

(12) PATENT APPLICATION PUBLICATION

(21) Application No.202141017970 A

(19) INDIA

(22) Date of filing of Application :19/04/2021

(43) Publication Date : 11/06/2021

(54) Title of the invention : FAST IMPROVED VEHICLE RECOGNITION TRACKING USING LPRS

(51) International classification	:G06K0009320000, G06K0009000000, G08G0001017000, G08G0001040000, G06K0009620000	(71)Name of Applicant : 1)SATHYAPRAKASH B.P. Address of Applicant :School of ECE, REVA University, Rukmini Knowledge Park, Kattigenathalli, Yelahanka, Bengaluru, Karnataka, Inda 560064. Karnataka India 2)PRATIK S. NILANGE 3)PRATHAB S 4)PRAJWAL P 5)MANOJ S. K 6)Dr. ROSHAN ZAMEER AHMED
(31) Priority Document No	:NA	(72)Name of Inventor :
(32) Priority Date	:NA	1)SATHYAPRAKASH B.P.
(33) Name of priority country	:NA	2)PRATIK S. NILANGE
(86) International Application No	:NA	3)PRATHAB S
Filing Date	:NA	4)PRAJWAL P
(87) International Publication No	: NA	5)MANOJ S. K
(61) Patent of Addition to Application	:NA	6)Dr. ROSHAN ZAMEER AHMED
Number	:NA	
Filing Date	:NA	
(62) Divisional to Application Number	:NA	
Filing Date	:NA	

(57) Abstract :

ABSTRACT: In every country, there is an evident increase in the number of vehicles on roads and this has become a major problem in traffic control, and vehicle owner identification. Sometimes it becomes difficult in identifying the vehicle number plates where the driver violates traffic and also drives very fast. However, though the vehicle checking system exists it has some faults such as leak checking, and false checking. Also, challenges arise due to the diversity of plate formats, character sizes, rotations, and illumination conditions often during the image acquisition. To avoid such a situation, an intelligent system for traffic surveillance is required where the system is built to meet the said requirements, and replace the traditional way of finding the theft vehicle or any vehicle blacklisted. The intelligent License Plate Recognition System (LPRS) detects the number of plates in the images captured by the camera, and also uses Optical Character Recognition (OCR) to recognize characters in the number plate. The system predicts the confidence of the algorithm enabling it to be smart and redundant free. Features such as Cloud & GPS functionalities are added value to the product by providing useful features to the user.

No. of Pages : 6 No. of Claims : 5

(12) PATENT APPLICATION PUBLICATION

(21) Application No.202141018147 A

(19) INDIA

(22) Date of filing of Application :20/04/2021

(43) Publication Date : 11/06/2021

(54) Title of the invention : WEB BLUEPRINT AND CODE CONSTRUCTION USING MACHINE INTELLIGENCE

(51) International classification	:G06N0003040000, G06K0009620000, G06N0003080000, G06Q0010060000, G06K0009000000	(71)Name of Applicant : 1) Dr. N. SABIYATHEFATIMA Address of Applicant :DEPARTMENT OF COMPUTER SCIENCE ENGINEERING, B.S. ABDUR RAHMAN CRESCENT INSTITUTE OF SCIENCE AND TECHNOLOGY, VANDALUR, CHENNAI, TAMIL NADU, INDIA - 600 048. Tamil Nadu India
(31) Priority Document No	:NA	2)VISHAAL SARAVANAN
(32) Priority Date	:NA	3)NIVETHA G
(33) Name of priority country	:NA	4)YASHWANTH RAJ V
(86) International Application No	:NA	5)ROOBESH BALAJI
Filing Date	:NA	6)MOHAMED ARSHAD S. S
(87) International Publication No	: NA	(72)Name of Inventor :
(61) Patent of Addition to Application Number	:NA	1) Dr. N. SABIYATHEFATIMA
Filing Date	:NA	2)VISHAAL SARAVANAN
(62) Divisional to Application Number	:NA	3)NIVETHA G
Filing Date	:NA	4)ROOBESH BALAJI
		5)MOHAMED ARSHAD S. S
		6)YASHWANTH RAJ V

(57) Abstract :

Much foundational research and groundbreaking progress are witnessed throughout the field of deep learning, machine translation, and computer vision for automatic code generation. The efficient model generates simplistic web design templates by following architecture workflow from hand-drawn images. Developing web templates from hand-drawn illustrations ensures that static product web pages are created faster with minimal workers and much lesser cost. The model pipeline practices the word-embedding system obtained by long short-term memory (LSTM) for code fragments. Also, canny edge detection algorithm provided with VGG19 convolutional neural net (CNN) and attention-based LSTM for web template production. Selected features are concatenated, and a terminal LSTM with a SoftMax function is called for final prediction. The proposed model is verified with a benchmark based on the BLUE score, and performance enhancement is compared among the existing image generation algorithms.

No. of Pages : 18 No. of Claims : 4

(12) PATENT APPLICATION PUBLICATION

(21) Application No.202141018724 A

(19) INDIA

(22) Date of filing of Application :23/04/2021

(43) Publication Date : 11/06/2021

(54) Title of the invention : LOW EARTH ORBIT SATELLITE TRACKING USING AUTOMATED POSITIONING OF ANTENNA

(51) International classification	:H04N0021240000, H04W0024100000, F04B0017030000, H01Q0003080000, F16K0031040000	(71) Name of Applicant : 1) Dr M DEVANATHAN Address of Applicant :SCHOOL OF ECE REVA UNIVERSITY, RUKMINI KNOWLEDGE PARK, KATTIGENAHALLI, YELAHANKA, BANGALORE, KARNATAKA, INDIA 560064. Karnataka India
(31) Priority Document No	:NA	2)SYED SAAD HUSSAIN
(32) Priority Date	:NA	3)VINOD R
(33) Name of priority country	:NA	4)PRAVEEN KUMAR C
(86) International Application No	:NA	5)MOHAMMED RAHMATHULLA
Filing Date	:NA	(72) Name of Inventor :
(87) International Publication No	: NA	1) Dr M DEVANATHAN
(61) Patent of Addition to Application Number	:NA	2)SYED SAAD HUSSAIN
Filing Date	:NA	3)VINOD R
(62) Divisional to Application Number	:NA	4)PRAVEEN KUMAR C
Filing Date	:NA	5)MOHAMMED RAHMATHULLA

(57) Abstract :

' This is a device that monitors the satellite as it travels through space. It is necessary to monitor the satellite and position the antenna to face it in order to receive signals efficiently. The system is originally constructed such that we must have an initial time and a final time, so that the system-rotates from one location to another for the duration. It is necessary to feed both the initial and final positions. 'The stepper motor used can handle up to 4.2 kilogrammes. An arduino nanp is used to feed the path and steps to the motor driver. The stepper motor is controlled by the motor driver. The Real Time clock module keeps track of the time so that the stepper motor moves at the start time and stops at the end time. . ' By our model we have made it possible to maneuver the antenna from north tp south angles depending upon the satellite position in its orbit.

No. of Pages : 5 No. of Claims : 3

(12) PATENT APPLICATION PUBLICATION

(21) Application No.202141019042 A

(19) INDIA

(22) Date of filing of Application :26/04/2021

(43) Publication Date : 11/06/2021

(54) Title of the invention : IOT APPROACH TO SAVE LIFE USING GPS FOR THE TRAVELLER DURING AN ACCIDENT

(51) International classification	:G08B0025000000, G08B0025010000, G08B0025080000, G07C0005080000, A42B0003040000	(71) Name of Applicant : 1) DILNA U Address of Applicant :SCHOOL OF ECE, REVA UNIVERSITY, RUKMINI KNOWLEDGE PARK, KATTIGENAHALLI, YELAHANKA, BANGALORE, KARNATAKA, INDIA - 560 064. Karnataka India
(31) Priority Document No	:NA	2)ABHISHEK M
(32) Priority Date	:NA	3)NOUMANA BEGUM
(33) Name of priority country	:NA	4)DUDEKULA ROSHNI
(86) International Application No	:NA	5)MANIK PRABHU
Filing Date	:NA	(72) Name of Inventor :
(87) International Publication No	: NA	1) DILNA U
(61) Patent of Addition to Application	:NA	2)ABHISHEK M
Number	:NA	3)NOUMANA BEGUM
Filing Date	:NA	4)DUDEKULA ROSHNI
(62) Divisional to Application Number	:NA	5)MANIK PRABHU
Filing Date	:NA	

(57) Abstract :

The main aim of the project is to design and develop a faster first aid service to the accident or in emergency conditions with the help of internet of things and GPS technologies. The rapid growth of technology and infrastructure has made our lives easier. The advent of technology has also increased the traffic hazards and the road accidents take place frequently which causes huge loss of life and property because of the poor emergency facilities. The accident detection project will provide an optimum solution to this drawback. IR sensors can be used as a crash or rollover detector of the vehicle during and after a crash. With signals from an IR sensor, a severe accident due to an obstacle can be recognized. When a vehicle meets with an accident or if a car rolls over, the sensor detects the signal and immediately sends it to the microcontroller. Microcontroller sends the alert message through the GSM module including the location and driver ID details to the registered hospital or a rescue team. So the emergency help team can immediately trace the location through the GPS module, after receiving the information. The location can also be viewed on Google maps. After confirming the location necessary action is taken. This project is useful in detecting the accident precisely by means of IR sensors. Once a person ID is received via message hospital can login to cloud to know the details of the person like NAME: Blood group, previous health issues: family details, person insurance details and organ donation agreement details, using this details it is very easy to provide first AID to the accident or emergency patient.

No. of Pages : 5 No. of Claims : 3

(12) PATENT APPLICATION PUBLICATION

(21) Application No.202141019809 A

(19) INDIA

(22) Date of filing of Application :30/04/2021

(43) Publication Date : 11/06/2021

(54) Title of the invention : IOT BASED SMART ALARM SYSTEM TO MONITOR MEDICATION OF ELDERLY PEOPLE AND PATIENTS

(51) International classification	:H04L0029080000, G08B0025010000, G06F0008200000, A61J0007040000, G08B0021040000	(71) Name of Applicant : 1)BHARATHI S H Address of Applicant :SCHOOL OF ECE REVA UNIVERSITY, RUKMINI KNOWLEDGE PARK, KATTIGENAHALLI, YELAHANKA, BANGALORE, KARNATAKA, INDIA - 560064. Karnataka India
(31) Priority Document No	:NA	2)RASHMITHA R
(32) Priority Date	:NA	3)SHREEVALLABHA A
(33) Name of priority country	:NA	4)SACHIN R
(86) International Application No	:NA	5)SHREYAS S
Filing Date	:NA	(72) Name of Inventor :
(87) International Publication No	: NA	1) BHARATHI S H
(61) Patent of Addition to Application Number	:NA	2)RASHMITHA R
Filing Date	:NA	3)SHREEVALLABHA A
(62) Divisional to Application Number	:NA	4)SACHIN R
Filing Date	:NA	5)SHREYAS S

(57) Abstract :

More than 15% of the world's population is constituted by elderly people leading to population ageing. In developing countries such as India, China etc., population ageing has become a major cause for increase in the death rate due to lack of self- care. In order to overcome these consequences an IOT based solution is implemented. Basically, IOT features connecting the real-world appliances and monitoring through the internet. This methodology is integrated in the custom alarm device to screen the medication of patients and elderly persons. The proposed model focuses on developing a portable application and an alarm device that is controlled by the application. The medications as per the prescription is sent via an android app to the device and the alert is set for the required time. Raspberry pi is used to accomplish the function of an alarm device. Firebase. is utilized as a primary platform in the application to serve as a cloud framework. Android app is used to serve the purpose of interaction with the device. Additionally, sensors such as temperature sensor and pulse rate sensor are used in the end device. The data from the sensor is automatically updated to the cloud and an alert is sent to the controller of the device via android app in the event of emergency.

No. of Pages : 5 No. of Claims : 5

(12) PATENT APPLICATION PUBLICATION

(21) Application No.202141019811 A

(19) INDIA

(22) Date of filing of Application :30/04/2021

(43) Publication Date : 11/06/2021

(54) Title of the invention : AN ADJUSTABLE DEVICE FOR MEASURING

(51) International classification	:A61B0017290000, G06T0011200000, A61L0031140000, G11C0016040000, G01N0033520000	(71) Name of Applicant : 1)Ms. AADHYA KRISHNA Address of Applicant :NO. 206, HOYSALA, MILLERS TANK BUND ROAD, BANGALORE - 560052. Karnataka India
(31) Priority Document No	:NA	(72) Name of Inventor :
(32) Priority Date	:NA	1) Ms. AADHYA KRISHNA
(33) Name of priority country	:NA	
(86) International Application No	:NA	
Filing Date	:NA	
(87) International Publication No	: NA	
(61) Patent of Addition to Application Number	:NA	
Filing Date	:NA	
(62) Divisional to Application Number	:NA	
Filing Date	:NA	

(57) Abstract :

This invention relates to an adjustable device for measuring and more particularly to the simple push-pull mechanism to adjust the container space to the desired measurement. An objective of the present invention is to provide end user simplicity in measuring device rather having complex

No. of Pages : 21 No. of Claims : 9

(12) PATENT APPLICATION PUBLICATION

(21) Application No.202141019816 A

(19) INDIA

(22) Date of filing of Application :30/04/2021

(43) Publication Date : 11/06/2021

(54) Title of the invention : DESIGN AND IMPLEMENTATION OF PRIVATE CLOUD STORAGE FOR ORGANIZATION

(51) International classification	:H04L0029080000, G06F0016130000, G06F0016000000, G06F0021620000, G06F0040134000	(71) Name of Applicant : 1)Dr. BHARATHI S.H Address of Applicant :SCHOOL OF ECE REVA UNIVERSITY, RUKMINI KNOWLEDGE PARK, KATTIGENAHALLI, YELAHANKA, BANGALORE, KARNATAKA, INDIA - 560064. Karnataka India
(31) Priority Document No	:NA	2)VENKATESH T
(32) Priority Date	:NA	3)UJWALKUMAR
(33) Name of priority country	:NA	4)PRIYANKA PATIL
(86) International Application No	:NA	5)VIKAS NAIK
Filing Date	:NA	(72) Name of Inventor :
(87) International Publication No	: NA	1) Dr. BHARATHI S.H
(61) Patent of Addition to Application	:NA	2)VENKATESH T
Number	:NA	3)UJWALKUMAR
Filing Date	:NA	4)PRIYANKA PATIL
(62) Divisional to Application Number	:NA	5)VIKAS NAIK
Filing Date	:NA	

(57) Abstract :

Cloud storage is file storage in the cloud (online). Instead of keeping your files on your local hard drive, external hard drive, or flash drive, you can save them online. There are multiple reasons to use cloud storage services. Maybe your local hard drives are running low on disk space, in which case you can use the cloud as extra storage. If you want to be able to stream your music collection from anywhere, access your work files at home, easily share vacation videos, etc., you can upload your files online to a cloud storage service. Another-reason to use cloud storage is if you want to keep important files secure behind a password and encryption. In short, cloud storage is helpful not only when it comes to backup but also for security and the ability to easily share files with others or access them yourself from anywhere: your phone, tablet, or another computer.

No. of Pages : 5 No. of Claims : 3

(12) PATENT APPLICATION PUBLICATION

(21) Application No.202141019819 A

(19) INDIA

(22) Date of filing of Application :30/04/2021

(43) Publication Date : 11/06/2021

(54) Title of the invention : FOOD WASTE MANAGEMENT USING MOBILE APPLICATION

(51) International classification	:A23L0033105000, G09B0019000000, A61K0038140000, A23L0023000000, B01D0061020000	(71) Name of Applicant : 1)VASI HEMANTH Address of Applicant :D17/1, KRISHNANAGAR, YERRAGUNTLA, KADAPA, ANDHRA PRADESH, INDIA, 516311 Andhra Pradesh India
(31) Priority Document No	:NA	2)VARSHINI V
(32) Priority Date	:NA	3)VARSHA C S
(33) Name of priority country	:NA	4)JUPALLI BALAJI
(86) International Application No	:NA	5)NITYA S
Filing Date	:NA	(72) Name of Inventor :
(87) International Publication No	: NA	1)VASI HEMANTH
(61) Patent of Addition to Application	:NA	2)VARSHINI V
Number	:NA	3)VARSHA C S
Filing Date	:NA	4)JUPALLI BALAJI
(62) Divisional to Application Number	:NA	5)NITYA S
Filing Date	:NA	

(57) Abstract :

Majority of people stop thinking about it, when something is thrown away. Yet, food is a common item which is wasted daily. It is a growing evidence that a significant, share of global food is thrown away every single day. Wasting food has started happening decades ago, the contribution to stop and manage this problem is in everyone's hands. Reducing Food waste is a key sustainability challenge for every one globally .Despite of the issue, the link between innovation practices and food waste management has grabbed a little attention in the past few years. With the advancement in technology, the amount of food wasted globally can be reduced to a huge percent. Additionally hunger is also a major problem that is related to food waste. This paper explains about a vast range of food and hunger management initiatives, methods to solve this problem globally.

No. of Pages : 12 No. of Claims : 4

(12) PATENT APPLICATION PUBLICATION

(21) Application No.202141020063 A

(19) INDIA

(22) Date of filing of Application :01/05/2021

(43) Publication Date : 11/06/2021

(54) Title of the invention : LOW-COST FATIGUE TEST RIG

(51) International classification :G01N0003320000,
B23K0035260000,
G01M0013000000,
H04M0001180000,
G01N0003340000

(31) Priority Document No :NA
(32) Priority Date :NA
(33) Name of priority country :NA
(86) International Application No :PCT// /
Filing Date :01/01/1900
(87) International Publication No : NA
(61) Patent of Addition to Application Number :NA
Filing Date :NA
(62) Divisional to Application Number :NA
Filing Date :NA

(71)Name of Applicant :

1)RAJESH S

Address of Applicant :ASSISTANT PROFESSOR,
DEPARTMENT OF MECHANICAL ENGINEERING, R.M.K.
ENGINEERING COLLEGE, R.S.M. NAGAR,
KAVARAIPETTAI. Tamil Nadu India

(72)Name of Inventor :

1)PARTHEEBAN K

2)MADHANKUMAR S

3)RAMESH P

4)LOKESH KUMAR P J

5)Dr. S D SEKAR

6)SIVAKKUMAR G

7)RAJESH S

(57) Abstract :

Fatigue is important in as much as it is the single largest cause of failure in metals, estimated to comprise approximately 90% of all metallic failures; polymers and ceramics (except for glasses) are also susceptible to this type of failure. Furthermore, fatigue is catastrophic and insidious, occurring very suddenly and without warning. By carrying out this test, the material strength to be varied is determined. Fabricating the apparatus of fatigue test rig using an electric motor and load is given gradually to determine the fatigue strength of material.

No. of Pages : 6 No. of Claims : 4

(12) PATENT APPLICATION PUBLICATION

(21) Application No.202141020107 A

(19) INDIA

(22) Date of filing of Application :03/05/2021

(43) Publication Date : 11/06/2021

(54) Title of the invention : ATMOSPHERIC PARAMETER TRACKING CANSAT USING HAB

(51) International classification	:G06Q0030020000, B64G0001000000, B64G0005000000, B64B0001580000, B63B0022000000	(71) Name of Applicant : 1)AKASH G Address of Applicant :# 1491 GURU KRUPA, FIRST MAIN ROAD, 2/A CROSS, KALYAN NAGAR, T.DASARAHALLI, BANGALORE, KARNATAKA, INDIA 560057. Karnataka India 2)ASHWIN ALEX GEORGE 3)ARJUN S 4)A G ANJU 5)Dr. DEVANATHAN M
(31) Priority Document No	:NA	(72) Name of Inventor :
(32) Priority Date	:NA	1) AKASH G
(33) Name of priority country	:NA	2)ASHWIN ALEX GEORGE
(86) International Application No	:NA	3)ARJUN S
Filing Date	:NA	4)A G ANJU
(87) International Publication No	: NA	5)Dr. DEVANATHAN M
(61) Patent of Addition to Application Number	:NA	
Filing Date	:NA	
(62) Divisional to Application Number	:NA	
Filing Date	:NA	

(57) Abstract :

Catching up to the frontier of space exploration requires tremendous resources, knowledge, and infrastructure. Therefore, space education is perceived as a process for accelerating space technology development. Most developed countries give priority to develop the literacy of space technology in their students in which the CanSat design is utilized as one tool to acquire an understanding of satellite operations. A CanSat is a simulation of a real satellite, integrated within the volume and shape of a soft drink can. The CanSat has constraints about dimensions, weight and expects an appropriate satellite design. The CanSat is then launched to an altitude of a few kilometres by a rocket or dropped from a platform or high-altitude balloon. The communication between the ground station and the CanSat should be achieved accurately for proper transmission and reception of data collected by using the Lora module. Lora is one of the technologies that have received significant attention by the research community in the recent years. LoRa (long range) Technology has revolutionized IoT (Internet of Things) by enabling data communication over a long range while using very low power and highly encrypted. We have chosen appropriate sensors for our CanSat keeping the cost, space, and effectiveness a key factor by opting sensors with maximum functionality. The CanSat built can be launched and used to monitor local weather for an area, in an economical way, used as a tech-demonstrator.

No. of Pages : 8 No. of Claims : 6

(12) PATENT APPLICATION PUBLICATION

(21) Application No.202141020282 A

(19) INDIA

(22) Date of filing of Application :04/05/2021

(43) Publication Date : 11/06/2021

(54) Title of the invention : COMPARISON OF VARIOUS CLUSTERING TECHNIQUES IN VANETS

<p>(51) International classification :H04W0084180000, H04W0004460000, G01C0021260000, H04N0001333000, B60Q0009000000</p> <p>(31) Priority Document No :NA</p> <p>(32) Priority Date :NA</p> <p>(33) Name of priority country :NA</p> <p>(86) International Application No Filing Date :NA</p> <p>(87) International Publication No : NA</p> <p>(61) Patent of Addition to Application Number Filing Date :NA</p> <p>(62) Divisional to Application Number Filing Date :NA</p>	<p>(71)Name of Applicant :</p> <p>1)Chaitanya Nukala, Assistant professor/ Department of CSE, Rajeev Gandhi Memorial College of Engineering and Technology Address of Applicant :Rajeev Gandhi Memorial College of Engineering and Technology, Nandyal, Kurnool, A.P-518501 Andhra Pradesh India</p> <p>2)Dr.Nidamanuru Srinivasa Rao, Assistant Professor/ Department of CSE, Potti Sriramulu Chalavadi Mallikarjuna Rao College of Engineering and Technology</p> <p>3)M.Amareswar, Assistant professor/ Department of CSE, Holy Mary Institute of Technology & Science</p> <p>4).Venkata Ramana, Assistant professor/Department of CSE, Holy Mary Institute of Technology & Science</p> <p>5)Aileni Eenaja, Assistant professor/ Department of CSE, Holy Mary Institute of Technology & Science</p> <p>6)Sumayya Afreen, Assistant professor/ Department of CSE, Stanley College of Engineering and Technology for Women</p> <p>7)Afreen Fatima Mohammed , Assistant professor/Department of IT, Stanley College of Engineering and Technology for Women</p> <p>8)Amtul Sana Amreen, Assistant professor/Department of CSE, Stanley College of Engineering and Technology for Women</p> <p>(72)Name of Inventor :</p> <p>1)Chaitanya Nukala, Assistant professor/ Department of CSE, Rajeev Gandhi Memorial College of Engineering and Technology</p> <p>2)Dr.Nidamanuru Srinivasa Rao, Assistant Professor/ Department of CSE, Potti Sriramulu Chalavadi Mallikarjuna Rao College of Engineering and Technology</p> <p>3)M.Amareswar, Assistant professor/ Department of CSE, Holy Mary Institute of Technology & Science</p> <p>4).Venkata Ramana, Assistant professor/Department of CSE, Holy Mary Institute of Technology & Science</p> <p>5)Aileni Eenaja, Assistant professor/ Department of CSE, Holy Mary Institute of Technology & Science</p> <p>6)Sumayya Afreen, Assistant professor/ Department of CSE, Stanley College of Engineering and Technology for Women</p> <p>7)Afreen Fatima Mohammed , Assistant professor/Department of IT, Stanley College of Engineering and Technology for Women</p> <p>8)Amtul Sana Amreen, Assistant professor/Department of CSE, Stanley College of Engineering and Technology for Women</p>
---	--

(57) Abstract :

Abstract In recent years, there will be a fast expansion in numerous vehicles flying on road. The concentration will be to enhance the navigation standards & road security with assistance of ITS. There will be a requirement for new services & applications in environment of vehicle for comfort & safety. The technical advancement is improved to prevent collisions, to access uninterrupted internet facilities •, to foresee road accidents, to understanding road situations, to extent the capacity of storage, to expand the range of transmission, and to avoid the wireless links interference. The idea of this manuscript will be to enhance ITS to develop the safety of road & navigation procedure. There are numerous methods in n communication. The efficient & effective methods are enhanced to identify the conditions of road with the support of vehicular communication •. This manuscript provides the foundation of intelligent vehicle transport framework •. Different reviews on clustering, VANET modeling, & its based methods are deliberated. Followed by a survey of MAC protocols, hybrid cluster methods for VANET road security applications, multi-level & multi-hop broadcast protocol is examined.

No. of Pages : 12 No. of Claims : 5

(54) Title of the invention : IMPLEMENTATION OF WOMEN SAFETY ELECTRONIC JACKET USING IOT

(51) International classification	:G08B0025010000, B60R0025102000, G08B0013140000, G08G0001000000, B60R0025250000	(71)Name of Applicant : 1)A. Raganna Address of Applicant :School of ECE, REVA University, Rukmini Knowledge Park, Kattigenahalli, Yelahanka, Bangalore, Karnataka, India 560064. Karnataka India 2)Bheemireddy Ekanth Reddy 3)Salla Tharakeswar Reddy 4)Talluri Nandini 5)Sri Krupa CH 6)Dr. Bharathi S.H
(31) Priority Document No	:NA	(72)Name of Inventor : 1)A. Raganna 2)Bheemireddy Ekanth Reddy 3)Salla Tharakeswar Reddy 4)Talluri Nandini 5)Sri Krupa CH 6)Dr. Bharathi S.H
(32) Priority Date	:NA	
(33) Name of priority country	:NA	
(86) International Application No	:NA	
Filing Date	:NA	
(87) International Publication No	: NA	
(61) Patent of Addition to Application Number	:NA	
Filing Date	:NA	
(62) Divisional to Application Number	:NA	
Filing Date	:NA	

(57) Abstract :

ABSTRACT: In today's world, women are feeling unsafe to travel alone whether it is a day or night. Now-a-days women are been attacked by men irrespective of their ages. Women are facing various problems which include robbery/theft, rape, molestation, eve-teasing and various other difficulties. The only thought haunting every girl is when they will . be able to move freely on the streets even in odd hours without worrying about their security. This project focuses on a security for women so that they will never feel . helpless. The system consists of various modules such as GSM, GPS, memory card, shock circuit, buzzer, camera, ESP 32 module. Today there are many cases which are happening about women. It is high time where women need a change. This project is based on women security where women feel protected. This paper describes about safety electronic jacket built for women. In public transport vehicles such as cars, buses and auto-rickshaws as nowadays women are being molested, kidnapped and harassed by the drivers. In each field there is a special impact of women like sports, dance, education, business, in politics also. Women are leading in each field. Are the girls in India are really safe Always we get the answer No. Hence implemented electronic system is fitted in the jacket which has GPS, GSM, Camera, Shock circuit, Buzzer, memory card, vibration sensor which are interfaced with ESP 32 board. This device helps the women in danger to be easily located with the help of global positioning system (GPS). Also messages and calls are given to alert their respective emergency contacts which are already stored in the microcontroller using global system for mobile communication (GSM). Hence this device serves handy when any women traveling outside feel insecure about her surroundings.

No. of Pages : 11 No. of Claims : 5

(12) PATENT APPLICATION PUBLICATION

(21) Application No.202141020323 A

(19) INDIA

(22) Date of filing of Application :04/05/2021

(43) Publication Date : 11/06/2021

(54) Title of the invention : TAMPERPROOF DELIVERY SYSTEM

(51) International classification	:H04L0029060000, A61M0015060000, G06Q0010080000, G07F0017120000, H04L0009320000	(71)Name of Applicant : 1)Dr. THANGARAJA ARUMUGAM Address of Applicant :4a/1, Rastha South Street, Melaseval, Tirunelveli 627452, Tamil Nadu, India Tamil Nadu India 2)Dr. S. SHAHUL HAMEED 3)Dr. R. ARUNA 4)Dr. J. BALAJI 5)VIGNESH KARTHIK S. A
(31) Priority Document No	:NA	(72)Name of Inventor : 1)Dr. THANGARAJA ARUMUGAM 2)Dr. S. SHAHUL HAMEED 3)Dr. R. ARUNA 4)Dr. J. BALAJI 5)VIGNESH KARTHIK S. A
(32) Priority Date	:NA	
(33) Name of priority country	:NA	
(86) International Application No	:NA	
Filing Date	:NA	
(87) International Publication No	: NA	
(61) Patent of Addition to Application	:NA	
Number	:NA	
Filing Date	:NA	
(62) Divisional to Application Number	:NA	
Filing Date	:NA	

(57) Abstract :

ABSTRACT TAMPERPROOF DELIVERY SYSTEM Disclosed is a tamperproof delivery system (100) for ensuring safe and allegation free delivery of articles to a customer, the system (100) comprising: a receptacle (102) configured to receive an article within, wherein the receptacle (102) comprises: a digital lock (200) embedded on the outer surface of the receptacle (102); a digital lock interface (202) configured to enable a user to enter a One-time Password (OTP) for unlocking the digital lock (200) of the receptacle (102) at the time of delivery; an emergency button (204) configured to unlock the digital lock (200) of the receptacle (102) in case the customer is unable to provide the One-time password; and a processing unit (206) connected to the digital lock (200), the digital lock interface (202), and the emergency button (204); a controller (110) in communication with the digital lock (200) of the receptacle (102) and a user device (106).

No. of Pages : 27 No. of Claims : 10

(54) Title of the invention : AN AI BASED SYSTEM FOR GLUCOSE MONITORING AND DETERMINING COMPLIANCE

<p>(51) International classification</p> <p>(31) Priority Document No</p> <p>(32) Priority Date</p> <p>(33) Name of priority country</p> <p>(86) International Application No Filing Date</p> <p>(87) International Publication No</p> <p>(61) Patent of Addition to Application Number Filing Date</p> <p>(62) Divisional to Application Number Filing Date</p>	<p>:A61B0005145000, A61B0005000000, G06N0003080000, G06N0020000000, H04L0012260000</p> <p>:NA</p> <p>:NA</p> <p>:NA</p> <p>:NA</p> <p>:NA</p> <p>:NA</p> <p>:NA</p> <p>:NA</p> <p>:NA</p> <p>:NA</p>	<p>(71)Name of Applicant : 1)Ms.M.Prabha Address of Applicant :Assistant Professor Department of Electronics and Communication Engineering St.Joseph College of Engineering Sriperumbudur, Chennai -602 117 Tamil Nadu India 2)Ms.R.Bhavani 3)Dr. Manish Upadhyay 4)M.Vijayaragavan 5)Mrs.M.Devika Rani 6)Dr. T. Prasanth 7)Dr. S. Vijayalakshmi 8)Dr.S.Sharon Priya 9)Kakirala Durga Bhavani 10)Mr.A.Muthuraman</p> <p>(72)Name of Inventor : 1)Ms.M.Prabha 2)Ms.R.Bhavani 3)Dr. Manish Upadhyay 4)M.Vijayaragavan 5)Mrs.M.Devika Rani 6)Dr. T. Prasanth 7)Dr. S. Vijayalakshmi 8)Dr.S.Sharon Priya 9)Kakirala Durga Bhavani 10)Mr.A.Muthuraman</p>
--	--	---

(57) Abstract :

ABSTRACT AN AI BASED SYSTEM FOR GLUCOSE MONITORING AND DETERMINING COMPLIANCE [033] The present invention discloses an AI based system for glucose monitoring and determining compliance. The system includes, but not limited to, an artificial intelligence (AI) module for learning and determining on the basis of previous history after performing analytics, the amount of delivery of insulin and compliances for various diabetic conditions; a cloud server in conjunction with the artificial intelligence (AI) module to store and process the information and further send it to the user device and determining the compliance for various diabetic conditions and insulin dose; and a user device with a user interface to take input from the user and further display the output values. Accompanied Drawing [FIG. 1]

No. of Pages : 22 No. of Claims : 7

(12) PATENT APPLICATION PUBLICATION

(21) Application No.202141020402 A

(19) INDIA

(22) Date of filing of Application :04/05/2021

(43) Publication Date : 11/06/2021

(54) Title of the invention : LITHIUM-ION BATTERY RANGE AND SOC PREDICTION FOR ELECTRIC VEHICLE

(51) International classification	:H01M0010052500, H01M0004360000, G01R0031392000, G06N0003080000, H01M0002100000	(71)Name of Applicant : 1)Dr. John Chembukkavu Address of Applicant :Head of the department , Department of Electrical and Electronics Engineering, IES College of Engineering, Thrissur-680551 Kerala India 2)Mr.M. Chithik Raja 3)Dr.Vishnu Rajan 4)Mr. Aneesh S 5)Ms. Anitha Mathew 6)Ms. Simitha K M 7)Mr.Sarun Kumar K P 8)Dr.Bobby N D 9)Mr.Arun Jose 10)Dr.S.Brilly Sangeetha
(31) Priority Document No	:NA	(72)Name of Inventor :
(32) Priority Date	:NA	1)Dr. John Chembukkavu
(33) Name of priority country	:NA	2)Mr.M. Chithik Raja
(86) International Application No	:NA	3)Dr.Vishnu Rajan
Filing Date	:NA	4)Mr. Aneesh S
(87) International Publication No	: NA	5)Ms. Anitha Mathew
(61) Patent of Addition to Application	:NA	6)Ms. Simitha K M
Number	:NA	7)Mr.Sarun Kumar K P
Filing Date	:NA	8)Dr.Bobby N D
(62) Divisional to Application Number	:NA	9)Mr.Arun Jose
Filing Date	:NA	10)Dr.S.Brilly Sangeetha

(57) Abstract :

ABSTRACT LITHIUM-ION BATTERY RANGE AND SoC PREDICTION FOR ELECTRIC VEHICLE Due to its growth over a more extended period, the new energy storage industry is the best alternative for lithium-ion battery technologies. The choice of the best modelling technique for battery ageing based on the investigated characterization of lifespan remains a problem. In this invention, the development and formation of various power fade models for comparing performance answers are based on a detailed data collection of Nickel Manganese-Cobalt Oxide (NMC) cells. The evaluation is done using a semi-empirical (SEM) simulation against an artificial neural network model and a machine learning model. One way of forecasting performance depletion is the Nonlinear Autoregressive Network (NARXnet) that can minimize computational effort. To explain the dynamic and nonlinear behaviour of Li-ion battery ageing, it indicates the relevance of methodological choices and model performance for existence. [FIG: 1]

No. of Pages : 16 No. of Claims : 4

(54) Title of the invention : SYSTEM AND METHOD FOR WASHING SOLAR PANEL WITH ADVANCED TECHNIQUE

<p>(51) International classification</p> <p>(31) Priority Document No</p> <p>(32) Priority Date</p> <p>(33) Name of priority country</p> <p>(86) International Application No Filing Date</p> <p>(87) International Publication No</p> <p>(61) Patent of Addition to Application Number Filing Date</p> <p>(62) Divisional to Application Number Filing Date</p>	<p>:F24S0040200000, G05D0001020000, A47L0001020000, B25J0009160000, F24S0030452000</p> <p>:NA</p> <p>:NA</p> <p>:NA</p> <p>:NA</p> <p>:NA</p> <p>:NA</p> <p>:NA</p> <p>:NA</p> <p>:NA</p> <p>:NA</p>	<p>(71)Name of Applicant :</p> <p>1)BATHALA NEERAJA, GOVERNMENT POLYTECHNIC. Address of Applicant :LECTURER, DEPARTMENT OF ELECTRICAL AND ELECTRONICS ENGINEERING, GOVERNMENT POLYTECHNIC, HYDERABAD 500028, TELANGANA, INDIA Telangana India</p> <p>2)Dr. SANDEEP TAYAL, MAHARAJA AGRASEN INSTITUTE OF TECHNOLOGY.</p> <p>3)Dr. AMITA GOEL, MAHARAJA AGRASEN INSTITUTE OF TECHNOLOGY.</p> <p>4)SUVEER CHANDRA DUBEY, INDORE INSTITUTE OF SCIENCE & TECHNOLOGY.</p> <p>5)RITU K R, UNIVERSITY INSTITUTE OF TECHNOLOGY.</p> <p>6)Dr. MOHAMMAD SHABAZ, LOVELY PROFESSIONAL UNIVERSITY.</p> <p>7)Dr. RAJESH KUMAR THEVASIGAMANI, KONERU LAKSHMAIAH EDUCATION FOUNDATION.</p> <p>8)Dr. D. KARUNKUZHALI, PANIMALAR ENGINEERING COLLEGE.</p> <p>9)Dr. SORAKAYA SOMANATHAN MANIVANNAN, VELLORE INSTITUTE OF TECHNOLOGY.</p> <p>10)SHAHUL HAMEED CHETTALI, SAVEETHA SCHOOL OF ENGINEERING.</p> <p>11)YOGENDRA KUMAR, VSP GOVERNMENT PG COLLEGE.</p> <p>12)Dr. CHENDRAPPA MUNI VELU, SAVEETHA SCHOOL OF ENGINEERING.</p> <p>(72)Name of Inventor :</p> <p>1)BATHALA NEERAJA, GOVERNMENT POLYTECHNIC.</p> <p>2)Dr. SANDEEP TAYAL, MAHARAJA AGRASEN INSTITUTE OF TECHNOLOGY.</p> <p>3)Dr. AMITA GOEL, MAHARAJA AGRASEN INSTITUTE OF TECHNOLOGY.</p> <p>4)SUVEER CHANDRA DUBEY, INDORE INSTITUTE OF SCIENCE & TECHNOLOGY.</p> <p>5)RITU K R, UNIVERSITY INSTITUTE OF TECHNOLOGY.</p> <p>6)Dr. MOHAMMAD SHABAZ, LOVELY PROFESSIONAL UNIVERSITY.</p> <p>7)Dr. RAJESH KUMAR THEVASIGAMANI, KONERU LAKSHMAIAH EDUCATION FOUNDATION.</p> <p>8)Dr. D. KARUNKUZHALI, PANIMALAR ENGINEERING COLLEGE.</p> <p>9)Dr. SORAKAYA SOMANATHAN MANIVANNAN, VELLORE INSTITUTE OF TECHNOLOGY.</p> <p>10)SHAHUL HAMEED CHETTALI, SAVEETHA SCHOOL OF ENGINEERING.</p> <p>11)YOGENDRA KUMAR, VSP GOVERNMENT PG COLLEGE.</p> <p>12)Dr. CHENDRAPPA MUNI VELU, SAVEETHA SCHOOL OF ENGINEERING.</p>
--	--	---

(57) Abstract :

Renewable energy is the need of the current situation, hence has growing interest such as photovoltaic energy based on the SPA technique. Efficient maintenance of photovoltaic panels has to be done for the system to work in a significant way. SPA technology is implemented in this invention which consists of three phases for an efficient cleaning process. The energy capacity of the system can be maintained by developing a periodic process of cleaning. SPA technology involves the movement of cleaning robots which are arranged in the form of an array over the panels. This technology used suction cups which are exploited used actuators through cables. The technology involves aerial robots implemented in the SPA method controlling both the position and the force exerted by the robots for performing the cleaning process on the solar panels. The mobility of the robots is low while performing the suction movement as it improves the stability of the system. The robots being driven by cable perform the process of cleaning effectively for a long array of panels fixed continuously. Motion is the cleaning robot is controlled by a smart controller which senses, plans and acts accordingly.

No. of Pages : 9 No. of Claims : 5

(12) PATENT APPLICATION PUBLICATION

(21) Application No.202141020431 A

(19) INDIA

(22) Date of filing of Application :04/05/2021

(43) Publication Date : 11/06/2021

(54) Title of the invention : A DEVICE FOR TRAPPING LOCUST

(51) International classification	:A23K0050100000, A01M0005080000, A01M0001220000, A01M0005000000, A01K0067033000	(71) Name of Applicant : 1)KARUNYA INSTITUTE OF TECHNOLOGY AND SCIENCES Address of Applicant :KARUNYA INSTITUTE OF TECHNOLOGY AND SCIENCES, KARUNYA NAGAR, COIMBATORE-641 114 Tamil Nadu India
(31) Priority Document No	:NA	(72) Name of Inventor :
(32) Priority Date	:NA	1)Dr.S.ELIZABETH AMUDHINI STEPHEN
(33) Name of priority country	:NA	2)Dr.SUJITHA JULIET
(86) International Application No	:NA	3)Dr.G.HEMALATHA
Filing Date	:NA	4)Mr.GEO KINGSLY LYNUS
(87) International Publication No	: NA	
(61) Patent of Addition to Application Number	:NA	
Filing Date	:NA	
(62) Divisional to Application Number	:NA	
Filing Date	:NA	

(57) Abstract :

A SYSTEM FOR LOCUST SWARM TRAP FOR CATTLE FEED CONVERSION AND THE METHOD INVOLVED THEREOF
A system for locust swarm trap for cattle feed conversion is designed that is used to attract the invading Schistocerca gregaria and further sucks the locusts and prevents it from invading the field and destroying the crops. The device is a pole mounted such that it is caught in the flight before it reached the field. The input device consists of a layer that produces an odour to attract the locusts and the suction unit(4) that pulls the locusts to the device. A filter media(2) filters the locusts and takes it to a collecting tank for further processing. The processing unit consists of a collecting tank, a rotary drier(8) and a crusher(10,11). The output from the device will be protein rich cattle feed. This device will address the threat for food security in the country due to the invasion of locust.

No. of Pages : 20 No. of Claims : 13

(12) PATENT APPLICATION PUBLICATION

(21) Application No.202141020435 A

(19) INDIA

(22) Date of filing of Application :05/05/2021

(43) Publication Date : 11/06/2021

(54) Title of the invention : SEMI AUTOMATIC PAPER CUTTING MACHINE USING GENEVA MECHANISM AND INDUSTRIAL INTERNET OF THINGS (IIOT)

<p>(51) International classification :H04L0029080000, B26D0001000000, F16H0027060000, H01H0003440000, B26D0005120000</p> <p>(31) Priority Document No :NA (32) Priority Date :NA (33) Name of priority country :NA (86) International Application No :NA Filing Date :NA (87) International Publication No : NA (61) Patent of Addition to Application Number :NA Filing Date :NA (62) Divisional to Application Number :NA Filing Date :NA</p>	<p>(71)Name of Applicant : 1)Dr.V. DHINAKARAN Address of Applicant :Professor, Department of Mechanical Engineering, Chennai Institute of Technology, Kundrathur, Chennai-69, Tamil Nadu. Ph:9941617332, 9080591216 E-Mail: dhinkaranv@citchennai.net Tamil Nadu India</p> <p>2)Dr. A. SATHISH KUMAR 3)Dr.RAM SUBBIAH 4)Dr.M. KUMAR 5)S RAMA LAKSHMI MALLADI 6)Dr.M. VEERAPATHRAN 7)Dr. S. AJITH ARUL DANIEL 8)Dr. V. SIVABHARATHI 9)Dr. M. THIRUCHITRAMBALAM 10)N S SIVAKUMAR 11)N. NAGARAJAN</p> <p>(72)Name of Inventor : 1)Dr.V. DHINAKARAN 2)Dr. A. SATHISH KUMAR 3)Dr.RAM SUBBIAH 4)Dr.M. KUMAR 5)S RAMA LAKSHMI MALLADI 6)Dr.M. VEERAPATHRAN 7)Dr. S. AJITH ARUL DANIEL 8)Dr. V. SIVABHARATHI 9)Dr. M. THIRUCHITRAMBALAM 10)N S SIVAKUMAR 11)N. NAGARAJAN</p>
---	--

(57) Abstract :

ABSTRACT OF THE INVENTION The design and fabrication of paper cutting machine using Geneva mechanism cuts the paper as per the fixed and required dimension given by the people. The objective of this concept is to design the Geneva mechanism operated paper cutting machine which eliminates the most time taking process of paper marking and helps in feed equal dimension paper in each rotation. The Geneva drive is an indexing mechanism that converts continuous motion into intermittent motion. By means of this mechanism the continuous rotary motion of the sprocket wheel is converted into intermittent rotary motion of roller. Due to which paper is moved between the equal intervals of cutting period. The paper cutting is achieved by the crank and lever mechanism. The sprocket will act as a crank, and then the cutter will act as a lever. These two links are connected by a connecting link. Then the cutter will be back to its original position by the spring effect. The machine is also connected to cloud using Industrial Internet of Things (IIOT). Two sensors are provided in the machine to switching ON and OFF the motor of the machine and one sensor is provided for counting the cuts. This ensures that user can set the quantity of paper he need to cut and when to switch on and off the machine from a remote location. This machine is also used to cut the various kind of paper products, plastic, thin film, leather, slice of nonferrous metal etc. It reduces the manual work of paper cutting, and also it saves the time. It is very useful for the paper manufacturing industry and it avoids the human errors. It can be also used in school, colleges, stationary shopTMs, paper stores, etc.

No. of Pages : 10 No. of Claims : 3

(12) PATENT APPLICATION PUBLICATION

(21) Application No.202141020488 A

(19) INDIA

(22) Date of filing of Application :05/05/2021

(43) Publication Date : 11/06/2021

(54) Title of the invention : CRATUS-THE BAG OF FUTURE

<p>(51) International classification :A45F0003040000, A45C0013020000, A45C0015000000, A45F0003020000, A45C0013100000</p> <p>(31) Priority Document No :NA (32) Priority Date :NA (33) Name of priority country :NA (86) International Application No :NA Filing Date :NA (87) International Publication No : NA (61) Patent of Addition to Application Number:NA Filing Date :NA (62) Divisional to Application Number :NA Filing Date :NA</p>	<p>(71)Name of Applicant : 1) Mr. B. SENTHIKUMAR Address of Applicant :DEPARTMENT OF PRODUCTION ENGINEERING, SRI SAIRAM ENGINEERING COLLEGE, WEST TAMBARAM, CHENNAI, TAMIL NADU - 600044. Tamil Nadu India 2)S. AADITHYA VIKRAM 3)K. LOKESH 4)K. NARAYANASHANKAR 5)R. ANIRUDDH 6)S. DIVYAPRABHU 7)F. JEHYNIN 8)R. SANTHOSH KUMAR 9)G. SOORIYA PRAGASH 10)Dr. G. PUTHILIBAI 11)Dr. S. ARUNPRASAD</p> <p>(72)Name of Inventor : 1) Mr. B. SENTHIKUMAR 2)S. AADITHYA VIKRAM 3)K. LOKESH 4)K. NARAYANASHANKAR 5)R. ANIRUDDH 6)S. DIVYAPRABHU 7)F. JEHYNIN 8)R. SANTHOSH KUMAR 9)G. SOORIYA PRAGASH 10)Dr. G. PUTHILIBAI 11)Dr. S. ARUNPRASAD</p>
--	--

(57) Abstract :

IN THE PRESENT INVENTION IP 68 WATERPROOF / DUST PROOF CRATUS BACKPACK FRAMES ARE DISCLOSED. THIS BAG HAS A BUILT IN PROVISION FOR POWERBANK, BUILT IN PROVISION FOR A FULL POWER STRIP WHICH (INDIA'S FIRST), AND WITH A SINGLE 240 v AC SUPPLY, TO CHARGE THE LAPTOP, TABLET, PHONE, POWERBANK AND ALL AT THE SAME TIME. THE BEST PART WE DON'T HAVE TO TAKE ANYTHING OUT OF YOUR BAG. FULL 180 DEGREE OPENING FOR EASY ACCESS. ORTHOPEDIC BACKSUPPORT AND STERNUM SUPPORT FOR EASY CARRY AND HIGHLY REDUCES PAIN. MESHED INVERTED OOPSILON DESIGN AND S-STRAPS FOR AIR FLOW AND BREATHABILITY ALSO, THE BAG PROVIDES INDIVIDUAL DEDICATED SPACES, AND A BEST IN CLASS VOLUME.

No. of Pages : 11 No. of Claims : 9

(12) PATENT APPLICATION PUBLICATION

(21) Application No.202141020489 A

(19) INDIA

(22) Date of filing of Application :05/05/2021

(43) Publication Date : 11/06/2021

(54) Title of the invention : DESIGN AND FABRICATION OF INBOARD BRAKING SYSTEM IN AN OFF-ROAD VEHICLE

(51) International classification	:B60T0008260000, B60T0001060000, B60T0013580000, B60T0001100000, B60T0008240000	(71) Name of Applicant : 1) PANDYARAJ. V Address of Applicant :DEPARTMENT OF MECHANICAL ENGINEERING, SRI SAIRAM ENGINEERING COLLEGE, WEST TAMBARAM, CHENNAI, TAMIL NADU, INDIA - 600044. Tamil Nadu India
(31) Priority Document No	:NA	(72) Name of Inventor :
(32) Priority Date	:NA	1)PANDYARAJ. V
(33) Name of priority country	:NA	2)RAVINDRAN.S
(86) International Application No	:NA	3)GANAPATHY.S
Filing Date	:NA	4)AVINASH. S
(87) International Publication No	: NA	5)SAI SUBRAMANYAM K
(61) Patent of Addition to Application Number:	:NA	6)SARAVANAN.S
Filing Date	:NA	7)RAGAVENDRAN. R
(62) Divisional to Application Number	:NA	8)DEEPAN KUMAR. R.V
Filing Date	:NA	

(57) Abstract :

A design and built of an off- road race vehicles were disclosed. This invention relates to a novel method for decelerating the vehicle is designed, known as inboard braking system / axle braking system, in which a single brake disc will be mounted on the rear axle of the vehicle. The hydraulic braking system with fixed calipers is used to lock all the four wheels within the predetermined distance and time. The stopping distance of this vehicle at the speed of 40km/hr is found to be 1.5 m. The pedal actuates the master cylinder and is capable of locking four wheels in static condition and dynamically on paved and unpaved surfaces. This new braking method is designed to eliminate recurring problem often encountered. A customized inboard braking system is typically designed as a problem solution for disc deformation. Moreover, the axle braking is to slow down or stop the vehicle safely and effectively by converting kinetic energy into heat.

No. of Pages : 19 No. of Claims : 6

(12) PATENT APPLICATION PUBLICATION

(21) Application No.202141020520 A

(19) INDIA

(22) Date of filing of Application :05/05/2021

(43) Publication Date : 11/06/2021

(54) Title of the invention : A VARIATIONAL AUTO-ENCODER CONVOLUTIONAL NEURAL NETWORK (VAE-CNN) MODEL TO IDENTIFY THE PREVALENCE OF DIABETIC RETINOPATHY DISEASE

(51) International classification	:G06N0003040000, G06K0009620000, G06N0003080000, G06K0009000000, G06T0007000000	(71)Name of Applicant : 1)Mrs. Y.Sravani Devi Address of Applicant :Assistant Professor, Department of Computer Science & Engineering, G. Narayanamma Institute of Technology & Science, Hyderabad, Telangana, INDIA Telangana India 2)Dr. Morampudi Mahesh Kumar 3)Dr. U. S. N. Raju 4)Dr. M. Seetha 5)Dr. N. Kalyani 6)Dr. V Dinesh Reddy 7)Dr. S. Phani Kumar
(31) Priority Document No	:NA	(72)Name of Inventor : 1)Mrs. Y.Sravani Devi 2)Dr. Morampudi Mahesh Kumar 3)Dr. U. S. N. Raju 4)Dr. M. Seetha 5)Dr. N. Kalyani 6)Dr. V Dinesh Reddy 7)Dr. S. Phani Kumar
(32) Priority Date	:NA	
(33) Name of priority country	:NA	
(86) International Application No	:NA	
Filing Date	:NA	
(87) International Publication No	: NA	
(61) Patent of Addition to Application Number	:NA	
Filing Date	:NA	
(62) Divisional to Application Number	:NA	
Filing Date	:NA	

(57) Abstract :

The data scarcity problem in eye dataset to detect eye diseases like diabetic retinopathy, glaucoma and ARMD leads to difficulty in building an affective model with high accuracy using machine learning algorithms or deep neural networks. Likely, optimizing a grading model to have strong generality requires a more data to train the dataset, which is exceedingly difficult for the high severity classes. Traditional data augmentation methods, including random flipping and left/right rotations, cannot generate data with high diversity. To address this, we propose a Variational Auto Encoder Convolutional Neural Network model (VAE-CNN) to synthesize the high-resolution retinal image data and identify the prevalence of the diabetic retinopathy disease. Every VAE can learn to reconstruct each class independently and generating new samples for each class. The pre-processed images are input to DL architecture (CNN in our invention) for the automatic extraction of features and their associated weights to learn the classification rules. The features weights are optimized recursively to ensure the best classification results. Finally, the optimized weights are tested on an unseen set of images.

No. of Pages : 17 No. of Claims : 5

(12) PATENT APPLICATION PUBLICATION

(21) Application No.202141020540 A

(19) INDIA

(22) Date of filing of Application :05/05/2021

(43) Publication Date : 11/06/2021

(54) Title of the invention : A SYSTEM FOR A REMOTELY OPERATED UNDERWATER VEHICLE FOR INSPECTION

(51) International classification	:B63G0008000000, E21B0033035000, B65H0075440000, B63C0011420000, B63C0011520000	(71) Name of Applicant : 1)Planys Technologies Private Limited Address of Applicant :No. 5, Jaya Nagar Extension, Balaji Nagar Main Road, G.K. Avenue, Puzhuthivakkam, Chennai 600091, Tamil Nadu, India Tamil Nadu India
(31) Priority Document No	:NA	(72) Name of Inventor :
(32) Priority Date	:NA	1)Vineet Upadhyay
(33) Name of priority country	:NA	2)Sanchit Gupta
(86) International Application No	:NA	3)Santhosh Ravichandran
Filing Date	:NA	4)Govindaraj K.
(87) International Publication No	: NA	
(61) Patent of Addition to Application Number	:NA	
Filing Date	:NA	
(62) Divisional to Application Number	:NA	
Filing Date	:NA	

(57) Abstract :

A system for a remotely operated underwater vehicle (ROV) for inspection, the system comprising: a safety and distribution box connected with a main power supply source for power distribution to the remotely operated underwater vehicle, a Control Station, a Tether Management System;a buoyant umbilical tether cable connected to the underwater vehicle;a control unit for controlling and operating the ROV; and a tether cable management system interfaced with said control unit for winding and unwinding the buoyant umbilical cable;the safety and distribution box generate a high voltage DC current and transmit to the ROV so that the ROV is capable to operate at predetermined maximum length of the umbilical cable.

No. of Pages : 43 No. of Claims : 21

(12) PATENT APPLICATION PUBLICATION

(21) Application No.202141020546 A

(19) INDIA

(22) Date of filing of Application :05/05/2021

(43) Publication Date : 11/06/2021

(54) Title of the invention : DETECTION OF FORMALDEHYDE IN MARKETED FISH USING X-FRACTAL UWB PATCH ANTENNA AND RADIO WAVES

(51) International classification	:H01Q0009040000, G01N0033120000, A23B0004220000, A01N0001000000, G01N0033020000	(71) Name of Applicant : 1)Dr. Neeraj Kumar Shukla Address of Applicant :Associate Professor, Department of Electrical Engineering, King Khalid University Abha, Kingdom of Saudi Arabia. Saudi Arabia 2)Pawan Kumar Verma 3)RAJKUMAR KRISHNAMURTHY 4)Dr. Rajesh Verma 5)Dr Javed Khan Bhutto 6)Dr.M.Ramkumar Raja
(31) Priority Document No	:NA	(72) Name of Inventor :
(32) Priority Date	:NA	1)Dr. Neeraj Kumar Shukla
(33) Name of priority country	:NA	2)Pawan Kumar Verma
(86) International Application No	:NA	3)RAJKUMAR KRISHNAMURTHY
Filing Date	:NA	4)Dr. Rajesh Verma
(87) International Publication No	: NA	5)Dr Javed Khan Bhutto
(61) Patent of Addition to Application	:NA	6)Dr.M.Ramkumar Raja
Number	:NA	
Filing Date	:NA	
(62) Divisional to Application Number	:NA	
Filing Date	:NA	

(57) Abstract :

Fish is an important food stuff and source of protein all over the world. The ingesting of fish has latterly perceived an upward trend about the issue of adulteration of fish with unsanctioned chemicals and condiments has also come into the light. Traders and suppliers use formalin as an additive substance in fish to outspread the storing life of fresh or chilled fish and artificially improve the sensory attributes. A toxic chemical, formalin is used to preserve bodies and prevent its decay in mortuaries. Even though, the volume of formalin content in fish shrinks tirelessly during storage but cannot be detached totally. Ingesting of fish adulterated with formalin can cause health issues such as abdominal discomfort, vomiting, renal injury, etc. The occurrence of naturally varying levels of formaldehyde present in different food materials including seafood due to post-mortem enzymatic reaction makes the monitoring of illegally added formalin difficult. The estimation of formalin content in fishes can be made as a cost effective solution by using Radio Frequency signal. The RF signal when propagated in free space exhibits three different properties such as reflection, diffraction and scattering according to the variable dielectrics present in free space. Freshness property of a fish has a considerable influence on its quality and has a unique dielectric value. When an RF signal is transmitted and received using the designed X-Fractal UWB Patch antenna the absorption coefficient, Reflection parameter and Diffracted parameter is measured. Fish industry experts say that formalin is sprayed or injected and fish are dipped in it to preserve it. When an RF signal is transmitted and received using the designed X-Fractal UWB Patch antenna the absorption coefficient, Reflection parameter and Diffracted parameter is measured and found to be different. An experiment is conducted for generating a data set with different concentrations of formalin. Therefore, when a fish is placed in our designed device depending upon the received coefficients our supervised learning algorithm predicts the Percentage of formalin content in fish.

No. of Pages : 23 No. of Claims : 9

(12) PATENT APPLICATION PUBLICATION

(21) Application No.202141020552 A

(19) INDIA

(22) Date of filing of Application :05/05/2021

(43) Publication Date : 11/06/2021

(54) Title of the invention : A METHOD FOR DESIGNING FOUNDATIONS OF INDUSTRIAL STRUCTURES AND STRUCTURES SUBJECTED TO DYNAMIC LOADS

(51) International classification	:E04H0009020000, G01N0003320000, E02D0001020000, E02D0027340000, E02D0027440000	(71) Name of Applicant : 1)Dr C.N.V. Satyanarayana Reddy Address of Applicant :Professor, Department of Civil Engineering, Andhra University College of Engineering, Andhra University, Visakhapatnam - 530003, Andhra Pradesh, India
(31) Priority Document No	:NA	Andhra Pradesh India
(32) Priority Date	:NA	(72) Name of Inventor :
(33) Name of priority country	:NA	1)Dr C.N.V. Satyanarayana Reddy
(86) International Application No	:NA	
Filing Date	:NA	
(87) International Publication No	: NA	
(61) Patent of Addition to Application Number	:NA	
Filing Date	:NA	
(62) Divisional to Application Number	:NA	
Filing Date	:NA	

(57) Abstract :

The present disclosure relates to a method for designing foundations of industrial structures and structures subjected to dynamic loads. Coefficient of elastic uniform compression (Cu) of soil, used in the determination of soil spring stiffness for design of foundations of industrial structures and structures subjected to dynamic loads, is generally determined from cyclic plate load tests. The values of Cu determined with respect to test plate size are corrected for actual foundation size based on BarkanTMs equation. The effect of shape of loading plate on Cu is studied in cohesionless and cohesive soils through small scale cyclic load tests conducted in the laboratory using square and circular loading plates of same size. The results of study revealed that the value of coefficient of elastic uniform compression (Cu) of circular test plate is about 0.85 and 1.2 times of Cu of square plate in fine sand and cohesive soils, respectively.

No. of Pages : 21 No. of Claims : 9

(12) PATENT APPLICATION PUBLICATION

(21) Application No.202141020564 A

(19) INDIA

(22) Date of filing of Application :05/05/2021

(43) Publication Date : 11/06/2021

(54) Title of the invention : PROPERTY PURCHASE BASED INCENTIVE REWARD SYSTEM FOR CUSTOMERS

(51) International classification	:G06Q0030020000, G06Q0030060000, G06Q0050160000, G06Q0050260000, G01V0003080000	(71) Name of Applicant : 1)Geddam Venkateswara Rao Address of Applicant :S/O Nageswara Rao, FF-1, 5th Floor, Gostani Apartment, Revenue Layout, PM Palem, Visakhapatnam- 530041, Andhra Pradesh, India. Andhra Pradesh India
(31) Priority Document No	:NA	(72) Name of Inventor :
(32) Priority Date	:NA	1)Geddam Venkateswara Rao
(33) Name of priority country	:NA	
(86) International Application No	:NA	
Filing Date	:NA	
(87) International Publication No	: NA	
(61) Patent of Addition to Application Number	:NA	
Filing Date	:NA	
(62) Divisional to Application Number	:NA	
Filing Date	:NA	

(57) Abstract :

ABSTRACT: Title: Property Purchase Based Incentive Reward System for Customers The present disclosure proposes a property purchase based incentive reward system for customers by a business organization for purchasing a property such as a real estate purchase or a daily commodity purchase or a precious metal purchase thereof. The system 100 comprises a purchase detection module 101, a registration module 102, an automatic filling module 103, a pool registration module 104, a rebirth ID generation module 105 and an incentive calculation module 106. The proposed system provides multiple and continuous incentives to the user without any contribution or promotion of the organization by the customer. The system provides continuous incentive rewards to the customer and corresponding nominees of the customer.

No. of Pages : 15 No. of Claims : 5

(12) PATENT APPLICATION PUBLICATION

(21) Application No.202141020565 A

(19) INDIA

(22) Date of filing of Application :05/05/2021

(43) Publication Date : 11/06/2021

(54) Title of the invention : PERCEPTIBLE SUCCOUR FOR VISUALLY IMPAIRED

(51) International classification	:G06K0009000000, G09B0021000000, A61H0003060000, B60W0030080000, A61F0009080000	(71) Name of Applicant : 1)Dr. Pydimarri Padmaja Address of Applicant :Professor Teegala Krishna Reddy Engineering College, Department of Electronics Communication Engineering (ECE), Meerpet Medbowli, TKR College Rd, Hyderabad, Telangana- 500097 Andhra Pradesh India
(31) Priority Document No	:NA	(72) Name of Inventor :
(32) Priority Date	:NA	1)Dr. Pydimarri Padmaja
(33) Name of priority country	:NA	
(86) International Application No	:NA	
Filing Date	:NA	
(87) International Publication No	: NA	
(61) Patent of Addition to Application Number	:NA	
Filing Date	:NA	
(62) Divisional to Application Number	:NA	
Filing Date	:NA	

(57) Abstract :

Visually impaired and Perceptible Succour people find difficulties detecting obstacles while walking, which makes it dangerous. The smart system comes as a proposed solution to help them to avoid obstacles around them. Object detection is a field of computer vision that detects instances of objects in images/videos which can then be converted to annotated text into voice responses. I proposed a smart solution based on a camera connected to a Raspberry Pi embedded board which captures the videos of the obstacles. The proposed system live streams the output of the camera to the Raspberry Pi board and sends feedback in the form of speech warning messages about the kind of objects present and basic positions of the objects in the person/cameraTMs view. This entire system can be made of compact size and can be attached to a hat so that it would become easy for the visually impaired people to carry it.

No. of Pages : 12 No. of Claims : 4

(12) PATENT APPLICATION PUBLICATION

(21) Application No.202141020598 A

(19) INDIA

(22) Date of filing of Application :06/05/2021

(43) Publication Date : 11/06/2021

(54) Title of the invention : IOT ENABLED SOLAR THERMAL STORAGE TANK IMPLANTED WITH PCM ROOM

<p>(51) International classification :F24S0060300000, F24D0011000000, F28D0020000000, F24D0017000000, F24S0060000000</p> <p>(31) Priority Document No :NA (32) Priority Date :NA (33) Name of priority country :NA (86) International Application No :NA Filing Date :NA (87) International Publication No : NA (61) Patent of Addition to Application Number :NA Filing Date :NA (62) Divisional to Application Number :NA Filing Date :NA</p>	<p>(71)Name of Applicant : 1)Dr. P. MANOJ KUMAR Address of Applicant :ASSISTANT PROFESSOR, DEPARTMENT OF MECHANICAL ENGINEERING, KPR INSTITUTE OF ENGINEERING AND TECHNOLOGY, ARASUR, COIMBATORE, TAMILNADU, INDIA 641407. Tamil Nadu India</p> <p>2)Mr. S. VASANTHASEELAN 3)Dr. RAM SUBBIAH 4)Dr. D.S. JENARIS 5)Dr. K. RAVI KUMAR 6)Dr. M. VIJAYAKUMAR 7)Mr. K. ABRAHAM 8)Dr. P. MICHAEL JOSEPH STALIN 9)Mr. K. SUBASH 10)Mr. M. PRATHIYUNNAN 11)Mr. Q. STALIN ANDREWS</p> <p>(72)Name of Inventor : 1)Dr. P. MANOJ KUMAR 2)Mr. S. VASANTHASEELAN 3)Dr. RAM SUBBIAH 4)Dr. D.S. JENARIS 5)Dr. K. RAVI KUMAR 6)Dr. M. VIJAYAKUMAR 7)Mr. K. ABRAHAM 8)Dr. P. MICHAEL JOSEPH STALIN 9)Mr. K. SUBASH 10)Mr. M. PRATHIYUNNAN 11)Mr. Q. STALIN ANDREWS</p>
---	---

(57) Abstract :

AnIoT enabled solar thermal storage tank implanted with PCM room comprises of a type of solar thermal tank (1) with a secondary water tank (9). The water (5) is stored in the solar thermal tank (1), which is new of this kind with an implanted semi-annular PCM storage room with fins (7) at its bottom. The thermal insulation material (3) is provided between outer and inner layer (2) of the water tank to minimize the heat loss. The organic, eco-friendly, harmless and highly efficient phase change material (6) is stored in the semi-annular room (7) for increasing thermal storage capacity of the solar thermal tank (1). Further, the solar thermal tank (1) is connected to a secondary water tank (9) through the insulated piping (8). The secondary tank (9) is used to tap-out the hot water at the required temperature from the solar thermal tank (1) and store at the desired temperature. A smart valve (4) is fitted near the solar thermal tank (1), which is operated through IoT (Internet of Things) technology using a smart phone. During the operation, the entire set-up is connected to the solar thermal collector (10).

No. of Pages : 14 No. of Claims : 3

(12) PATENT APPLICATION PUBLICATION

(21) Application No.202141020611 A

(19) INDIA

(22) Date of filing of Application :06/05/2021

(43) Publication Date : 11/06/2021

(54) Title of the invention : WATER LEVEL AND WATER DISCHARGE MONITORING OF INLAND WATER BODIES USING LEO SATELLITE CONSTELLATION

(51) International classification	:H04B0007185000, G01F0001660000, H04B0007195000, G06Q0010040000, G06Q0010060000	(71) Name of Applicant : 1) VELS INSTITUTE OF SCIENCE, TECHNOLOGY & ADVANCED STUDIES(VISTAS) Address of Applicant :VELS INSTITUTE OF SCIENCE, TECHNOLOGY & ADVANCED STUDIES(VISTAS), VELAN NAGAR, PV VAITHIYALINGAM RD, PALLAVARAM, CHENNAI, TAMIL NADU - 600117, INDIA. Tamil Nadu India
(31) Priority Document No	:NA	(72) Name of Inventor :
(32) Priority Date	:NA	1) Dr. G. SUSEENDRAN
(33) Name of priority country	:NA	2)Dr. D. AKILA
(86) International Application No	:NA	3)Dr. R. JAYAKARTHIK
Filing Date	:NA	4)Ms. K. PARVATHAVARTHINI
(87) International Publication No	: NA	
(61) Patent of Addition to Application Number	:NA	
Filing Date	:NA	
(62) Divisional to Application Number	:NA	
Filing Date	:NA	

(57) Abstract :

River discharge measurements play an important role in applications such as flood management, climate studies and water resources management. Hence the requirement for long-term, continuous, spatially consistent and readily available river discharge data is high. Recent advances in satellite-based optical remote sensors have improved the field of surface water monitoring to next level. This research designs Low Earth orbit (LEO) satellite constellation-based IoT services for water level and water discharge monitoring of inland water bodies. The IoT sensors consist of Arduino, ultrasonic and flow rate sensors, which are deployed above the water to be monitored. They will measure the altitude, width and velocity of the river. The IoT sensors can detect the presence of the satellite and directly sends the collected river water information to the satellite. The satellites will store and forward the data from IoT sensors to the ground stations. The ground stations act as a gateway between the end-user and IoT sensors. At the end user terminal, a diagnostic decision system is developed where the risks of flood are computed based on the sensed data. The computed risks will be used for broadcasting warning messages to all citizens present in that region, using a risk-warning scheduling mechanism

No. of Pages : 8 No. of Claims : 6

(12) PATENT APPLICATION PUBLICATION

(21) Application No.202141020620 A

(19) INDIA

(22) Date of filing of Application :06/05/2021

(43) Publication Date : 11/06/2021

(54) Title of the invention : SYSTEM AND METHOD FOR SECURE TRANSMISSION IN MOBILE AD HOC NETWORKS USING TRUST MANAGEMENT

(51) International classification	:H04W0084180000, H04L0029060000, H04W0040240000, H04W0012120000, G06F0021570000	(71) Name of Applicant : 1) VELS INSTITUTE OF SCIENCE, TECHNOLOGY & ADVANCED STUDIES(VISTAS) Address of Applicant :VELS INSTITUTE OF SCIENCE, TECHNOLOGY & ADVANCED STUDIES(VISTAS), VELAN NAGAR, PV VAITHIYALINGAM RD, PALLAVARAM, CHENNAI, TAMIL NADU - 600117, INDIA. Tamil Nadu India
(31) Priority Document No	:NA	(72) Name of Inventor :
(32) Priority Date	:NA	1) Dr. V. JAYALAKSHMI
(33) Name of priority country	:NA	2)Dr. S. JAYALAKSHMI
(86) International Application No	:NA	3)Dr. S. PRASANNA
Filing Date	:NA	
(87) International Publication No	: NA	
(61) Patent of Addition to Application Number	:NA	
Filing Date	:NA	
(62) Divisional to Application Number	:NA	
Filing Date	:NA	

(57) Abstract :

A Mobile ad hoc networks (MANETs) consist or a collection or wireless mobile nodes which dynamically exchange data among themselves without the reliance on a fixed base station or a wired backbone network. Due to the openness in network topology, the security of communication in ad hoc wireless networks is significant, and worth following, especially in military applications. Collaboration is fruitful only if all participants operate in an authentic manner. Therefore, establishing and quantifying trust, which is the main impetus for collaboration, is very important for securing distributed networks. In this method, the trust value is estimated based on the node's malicious behavior which can be predicted by considering three essential factors namely (1)the total number of packets forwarded (2) the number of packets correctly transmitted by the node, and (3) the importance of the packets transmitted by the node. The trust value is propagated to each node which does not have a trust value and attains the most trustable path. In trust vector, the most trustable path can be computed as the maximal product value of all directed edges along a path. The path obtained by this method yields not only the path with trusted nodes but also the number of hops is less.So this method provides a secure transimission in the network.

No. of Pages : 11 No. of Claims : 8

(54) Title of the invention : IOT ENABLED WATER QUALITY MONITORING AND ALERTING SYSTEM FOR HOME WATER PURIFIER

(51) International classification	:H04L0029080000, G01N0033180000, H04L0029060000, G05B0019042000, H04L0012260000	(71) Name of Applicant : 1) VELS INSTITUTE OF SCIENCE, TECHNOLOGY & ADVANCED STUDIES(VISTAS) Address of Applicant :VELS INSTITUTE OF SCIENCE, TECHNOLOGY & ADVANCED STUDIES(VISTAS), VELAN NAGAR, P V VAITHIYALINGAM RD, PALLAVARAM, CHENNAI, TAMILNADU-600117, INDIA. Tamil Nadu India
(31) Priority Document No	:NA	(72) Name of Inventor :
(32) Priority Date	:NA	1) Mrs.K. KALAIVANI
(33) Name of priority country	:NA	2)Mrs.K. ULAGAPRIYA
(86) International Application No	:NA	3)Mrs.A. SARITHA
Filing Date	:NA	4)Mr. SYED RIZWAN
(87) International Publication No	: NA	5)Ms. USHA KUMARI
(61) Patent of Addition to Application Number	:NA	
Filing Date	:NA	
(62) Divisional to Application Number	:NA	
Filing Date	:NA	

(57) Abstract :

I Smart solutions for water quality monitoring are gaining importance with advancement in communication technology. This project a detailed overview of recent works carried out in the field of monitoring water through smart sensing using IoT. Also, a power efficient, simpler solution for water quality monitoring based on Internet of Things technology is presented. The model developed is used for testing water samples and the data uploaded over the Internet are analyzed. The system also provides an alert to a user and also to the nearby service centre when there is a deviation of water quality parameters from the pre-defined set of standard values. The proposed system is turbidity, temperature and Ph. The Arduino microcontroller forms a central part of monitoring water; it is observed that most of the IOT based solutions use a controller with external Wi-Fi. Such designs are notjcost effective and power efficient. Here the ESP8266 Wi-Fi Module is a self-contained SOC.with integrated TCP/IP) protocol stack that can give any microcontroller access to your Wi-Fi network. The ESP8266 is capable of either hosting an application or offloading all Wi-Fi networking functions from another application processor. Sensors are directly interfaced to the controller since the proposed system is to monitor domestic water. The sensor parameters such as, turbidity, temperature and pH are measured by placing the sensor into the RO Purifier. The measured parameters can be viewed by using LCD. The data from the sensors are sent to the cloud using the controller. Threshold is set in the cloud based on the standards provided by WHO. Messages are sent from cloud to the users mobile if the value exceeds the threshold. A mobile application has been developed in which values obtained by each sensor in the cloud can be viewed. Data sent from the controller is stored in Ubidots cloud. Ubidots offers a platform for developers to capture data and turn it into useful information. The features include a real-time dashboard to analyze data or control devices and share the data through public links. Data stored in the cloud can be used for detailed analysis. The cloud is programmed to send alert SMS messages whenever the monitored parameter exceeds the threshold limit.

No. of Pages : 8 No. of Claims : 7

(12) PATENT APPLICATION PUBLICATION

(21) Application No.202141020622 A

(19) INDIA

(22) Date of filing of Application :06/05/2021

(43) Publication Date : 11/06/2021

(54) Title of the invention : DEVELOPMENT OF BUCCAL ADHESIVE FILM CONTAINING COMBINATION OF ANTI-OXIDANTS FOR PREVENTING THE PROGR

(51) International classification	:A61K0009000000, A61K0049000000, A61K0036310000, A61K0033340000, A61B0005000000	(71) Name of Applicant : 1) VELS INSTITUTE OF SCIENCE, TECHNOLOGY & ADVANCED STUDIES(VISTAS) Address of Applicant :VELS INSTITUTE OF SCIENCE, TECHNOLOGY & ADVANCED STUDIES(VISTAS), VELAN NAGAR, PV VAITHIYALINGAM RD, PALLAVARAM, CHENNAI, TAMIL NADU - 600117, INDIA. Tamil Nadu India
(31) Priority Document No	:NA	(72) Name of Inventor :
(32) Priority Date	:NA	1) Dr. SHANMUGASUNDARAM P
(33) Name of priority country	:NA	2)Dr. SATHESH KUMAR S
(86) International Application No	:NA	3)Mrs. BHARGAVI B
Filing Date	:NA	
(87) International Publication No	: NA	
(61) Patent of Addition to Application Number	:NA	
Filing Date	:NA	
(62) Divisional to Application Number	:NA	
Filing Date	:NA	

(57) Abstract :

The possibilities of developing oral lesions into a malignant tumor were extensively studied by various oral oncologists. Treating the buccal lesions for the patients is a big task for the physicians. The oral mucosa is highly versatile and the presence of secretion makes it non-stickier to any topical agents. Presences of any foreign substances inside the buccal cavity stimulate the salivary/mucous secretions, thereby quickly draining the topical applications into the gut. The buccal mucosa is the best suited site for local, as well as systemic delivery of drugs due to its physiological features. It is an elegant and effective dosage form with improved bioavailability. It bypasses the hepatic first pass metabolism and does not require swallowing. The effectiveness is enhanced by incorporation of tailored combination of mucoadhesive polymers. The present invention consists of: a. A Novel combination of antioxidants with property to prevent the progression of cancerous lesions towards malignancy b. Buccal film that can deliver the incorporated antioxidants to release effectively on the required site. c. A polymeric combination to enhance the mucoadhesion to the oral mucosa for enhanced delivery of the incorporated agents.

No. of Pages : 12 No. of Claims : 6

(12) PATENT APPLICATION PUBLICATION

(21) Application No.202141020623 A

(19) INDIA

(22) Date of filing of Application :06/05/2021

(43) Publication Date : 11/06/2021

(54) Title of the invention : AN INITIAL STEP TO IMPLEMENT SMART BINS IN CHENNAI LOCAL TRAINS

(51) International classification	:B65F0001000000, B65F0007000000, G06Q0050300000, B61D0041000000, G09B0019000000	(71)Name of Applicant : 1) VELS INSTITUTE OF SCIENCE, TECHNOLOGY & ADVANCED STUDIES(VISTAS) Address of Applicant :VELS INSTITUTE OF SCIENCE, TECHNOLOGY & ADVANCED STUDIES(VISTAS), VELAN NAGAR, PV VAITHIYALINGAM RD, PALLAVARAM, CHENNAI, TAMIL NADU - 600117, INDIA. Tamil Nadu India
(31) Priority Document No	:NA	(72)Name of Inventor :
(32) Priority Date	:NA	1)Dr. A. PREMA KIRUBAKARAN
(33) Name of priority country	:NA	2)Dr. R. RENUGA DEVI
(86) International Application No	:NA	3)Dr. B. BOOBA
Filing Date	:NA	4)Dr. A. THIRUNURTHI RAJA
(87) International Publication No	: NA	5)Dr. NONGMAITHEM AJITH SINGH
(61) Patent of Addition to Application Number	:NA	6)Dr. V. VASANTHI
Filing Date	:NA	7)Mr. S. GOPALAKRISHNAN
(62) Divisional to Application Number	:NA	8)Mr. G. M. SRIDHAR
Filing Date	:NA	9)Mrs. J. LYSA EBEN

(57) Abstract :

An everyday journey in a local train drives us into many ideas. Watching out through the window and you see people littering around, with overflowing dustbins inside the train, paved way to sow this idea of clearing the dustbins ,once it is filled by using smart sensor recognition. The dustbins in a train need to be equipped with a sensor, once it is filled an indicator will indicate the status of the bin filling and this in turn will be emptied in the next nearest station. The nearest station will be always in a standby position to accept the trash from the train dustbin. The process repeats from filling in to getting emptied in a recursive way. This is ah initial process to save our tracks from litter. If this is successful, next we can implement in the passenger and express trains.

No. of Pages : 9 No. of Claims : 6

(12) PATENT APPLICATION PUBLICATION

(21) Application No.202141020624 A

(19) INDIA

(22) Date of filing of Application :06/05/2021

(43) Publication Date : 11/06/2021

(54) Title of the invention : DRONE DETECTION

(51) International classification	:G06K0009000000, G06N0003040000, B64C0039020000, G06K0009620000, G06K0009460000	(71) Name of Applicant : 1) VELS INSTITUTE OF SCIENCE, TECHNOLOGY & ADVANCED STUDIES(VISTAS) Address of Applicant :VELS INSTITUTE OF SCIENCE, TECHNOLOGY & ADVANCED STUDIES(VISTAS), VELAN NAGAR, P V VAITHIYALINGAM RD, PALLAVARAM, CHENNAI, TAMILNADU-600117, INDIA. Tamil Nadu India
(31) Priority Document No	:NA	(72) Name of Inventor :
(32) Priority Date	:NA	1) Dr. K. PRIYADARSINI
(33) Name of priority country	:NA	2)Mr. GOWRISHANKAR R
(86) International Application No	:NA	3)Mr. ASHOK T
Filing Date	:NA	
(87) International Publication No	: NA	
(61) Patent of Addition to Application Number	:NA	
Filing Date	:NA	
(62) Divisional to Application Number	:NA	
Filing Date	:NA	

(57) Abstract :

Drones are Unmanned Aerial Vehicles. The drones are used in delivering goods, medicines, food items and also used to monitor crowd and public events. Sometimes it may be used to capture the personal information. To avoid such circumstances; we need to detect drones in advance. We compared the existing computer vision methods such as background subtraction, edge detection, optical flow and frame difference for object detection. In our work, we used Convolutional Neural Network for both object detection and classification to enhance its performance.

No. of Pages : 8 No. of Claims : 5

(54) Title of the invention : ADDRESSING TWITTER SPAM DRIFT PROBLEM USING SEMI-SUPERVISED LEARNING APPROACH

(51) International classification	:G06N0020000000, H04L0012580000, G06N0007000000, G06N0005000000, G06F0016300000	(71) Name of Applicant : 1)L A Lalitha Address of Applicant :Assistant Professor, School of Computing and Information Technology, REVA University, Bengaluru lalitha.la@reva.edu.in Karnataka India
(31) Priority Document No	:NA	(72) Name of Inventor :
(32) Priority Date	:NA	1)Libina B Thomas
(33) Name of priority country	:NA	2)Mona Nirvinda P
(86) International Application No	:NA	3)N B Mounika
Filing Date	:NA	4)L A Lalitha
(87) International Publication No	: NA	5)Dr. Vishwanath R Hulipalled
(61) Patent of Addition to Application Number	:NA	
Filing Date	:NA	
(62) Divisional to Application Number	:NA	
Filing Date	:NA	

(57) Abstract :

Twitter has revolutionized how people obtain information by encouraging them to share their thoughts and opinions on everyday tweets. Unfortunately, spammers have found Twitter to be very appealing as a result of its high popularity. In contrast to other forms of spam, Twitter spam has become a major problem in recent years. A large number of users and a large volume of information exchanged on Twitter contribute significantly to the dissemination of spam. Twitter and the research community have been designing various spam detection systems using different machine-learning techniques in order to protect users. However, a recent study found that existing machine learning-based detection systems are unable to reliably detect spam because the characteristics of spam tweets change over time. The problem is known as Twitter Spam Drift. To address this, a semi-supervised learning method (SSLA) has been proposed in the proposed framework. The new method learns the domain structure by using unlabeled data. The analysis uses a live Twitter stream of data to deal with the drift. Machine learning is used to detect spam and non-spam users after pre-processing of live-downloaded data. Experiments were performed using several machine-learning algorithms, resulting in using the best performing algorithm for the proposed problem in terms of accuracy.

No. of Pages : 5 No. of Claims : 2

(54) Title of the invention : SYSTEM FOR EFFICIENT TRANSPORTATION OF MEDICAL OXYGEN TO COVID PATIENTS AT HOME QUARANTINE

<p>(51) International classification</p> <p>(31) Priority Document No</p> <p>(32) Priority Date</p> <p>(33) Name of priority country</p> <p>(86) International Application No Filing Date</p> <p>(87) International Publication No</p> <p>(61) Patent of Addition to Application Number Filing Date</p> <p>(62) Divisional to Application Number Filing Date</p>	<p>:A61G0010020000, A61M0016120000, A61M0016000000, B01D0053053000, F17C0013080000</p> <p>:NA</p> <p>:NA</p> <p>:NA</p> <p>:NA</p> <p>:NA</p> <p>:NA</p> <p>:NA</p> <p>:NA</p> <p>:NA</p> <p>:NA</p>	<p>(71)Name of Applicant :</p> <p>1)Dr.K.Dhayalini Address of Applicant :Professor and Head, Department of Electrical and Electronics Engineering, K.Ramakrishnan College of Engineering (Autonomous), Samayapuram, Tiruchirappalli-621112, Tamilnadu, India. Tamil Nadu India</p> <p>2)Dr. N. Shanmuga priya</p> <p>3)Dr.V.Kathiresan</p> <p>4)Prof.S.Nithyanandh</p> <p>5)Preethi B</p> <p>6)Dr.R.Kumar</p> <p>7)Dr.S.Sasikala Devi</p> <p>8)Ms. Dimple Chawla</p> <p>9)ANU C.S</p> <p>10)Dr. Bhavik U swadia</p> <p>11)Dr. Md. Khaja Mohiddin</p> <p>12)Dr.S.Balamurugan</p> <p>(72)Name of Inventor :</p> <p>1)Dr.K.Dhayalini</p> <p>2)Dr. N. Shanmuga priya</p> <p>3)Dr.V.Kathiresan</p> <p>4)Prof.S.Nithyanandh</p> <p>5)Preethi B</p> <p>6)Dr.R.Kumar</p> <p>7)Dr.S.Sasikala Devi</p> <p>8)Ms. Dimple Chawla</p> <p>9)ANU C.S</p> <p>10)Dr. Bhavik U swadia</p> <p>11)Dr. Md. Khaja Mohiddin</p> <p>12)Dr.S.Balamurugan</p>
--	--	--

(57) Abstract :

The System for Efficient Transportation of Medical Oxygen to COVID Patients at Home Quarantine (ETMOCP) helps the COVID patients to make use of the ETMOCP to supply the oxygen at home efficiently in an uninterrupted manner. The oxygen tank stores the oxygen in bulk in a particular street or a locality. The electric post and electric line already have a connection with every home. Here, to the below of electric line with safe distance, the oxygen line is placed with the help of the electric post. Every home has a connection from the oxygen line. A COVID patient is in-home quarantine and requires medical oxygen, then he needs to inform the control unit of the oxygen tank. Then the officials of the control unit make necessary arrangements for the requested patient to utilize the medical oxygen at home. The gas sensor with the speaker alerts the user when there is a leakage. The ETMOCP control unit helps to monitoring and managing the successful functioning of the whole ETMOCP system. By using this ETMOCP, the COVID patients make use of the ETMOCP to supply the oxygen at home efficiently in an uninterrupted manner.

No. of Pages : 16 No. of Claims : 3

(12) PATENT APPLICATION PUBLICATION

(21) Application No.202141020752 A

(19) INDIA

(22) Date of filing of Application :07/05/2021

(43) Publication Date : 11/06/2021

(54) Title of the invention : DOMESTIC GAS BURNER FOR LARGE BOTTOM COOKWARE

(51) International classification :F23D0014060000,
F23D0014700000,
F23D0014580000,
F24C0003080000,
F23D0014020000

(31) Priority Document No :NA
(32) Priority Date :NA
(33) Name of priority country :NA
(86) International Application No :NA
Filing Date :NA
(87) International Publication No : NA
(61) Patent of Addition to Application Number:NA
Filing Date :NA
(62) Divisional to Application Number :NA
Filing Date :NA

(71)**Name of Applicant :**
1)Dr. ZEENATHUL FARIDA ABDUL GANI
Address of Applicant :Professor, Department of Mechanical
Engineering Francis Xavier Engineering College Tirunelveli,
Tamil Nadu Tamil Nadu India
2)Mr. S. DANI

(72)**Name of Inventor :**
1)Mr. S. DANI
2)Dr. ZEENATHUL FARIDA ABDUL GANI

(57) Abstract :

Domestic gas burner is considered as one of the powerful devices invented without any moving parts. The design treatment of these burners has changed over years in various aspects still providing a huge scope for better design. These burners are primarily used indoors which demands safe, stable and efficient functioning. To improve the safety and stable functioning of domestic gas burner, a new burner design has been developed. The proposed burner design is suitable for any commercial gas stoves and can also be employed as a retrofit option with slight modification in existing stoves. The fuel ports in the primary burner head facilitates swirl flow which ensures extended residential time and enhanced mixing. This also improves better anchoring of flamelets to the mouth of the ports leading to better flame stability. Another unique design feature is the circumferential outer ring with an independent mixing tube and control knob. The circumferential outer ring is optional and can be used when cookware with large bottom area is used. This additional feature aids in fast cooking and reduces heat loss due to radiation and convection. Swirl induced flame guarantees complete combustion leading to less pollutant emission. The new burner prototype has been developed with the conventional table top burner specification as reference. A set of preliminary experiments have also been made with varying equivalence ratio and two different diameter bottom cookware. The results from the experiments show an increase in thermal efficiency and reduced cooking time. The increase in efficiency is higher at low equivalence ratio.

No. of Pages : 18 No. of Claims : 8

(12) PATENT APPLICATION PUBLICATION

(21) Application No.202141020753 A

(19) INDIA

(22) Date of filing of Application :07/05/2021

(43) Publication Date : 11/06/2021

(54) Title of the invention : REMOTE CONTROLLED AIR VEHICLE BASED SANITIZING SYSTEM WITH PAYLOAD CARRIER

(51) International classification	:B64C0039020000, A61L0002100000, A61L0002180000, F24F0003160000, A61K0009510000	(71)Name of Applicant : 1)Dr. Raghu Chandra Garimella Address of Applicant :Department of Electrical and Electronics Engineering, Methodist College of Engineering and Technology, Osmania University, Abids, Hyderabad, Telangana, India. Telangana India 2)Dr. Siva Rama Krishna Madeti 3)Dyava SaiBharath Krishna Reddy 4)Nattala Shiva Kumar 5)Butharaju Saidivya 6)Takkala Soumya 7)Chepuri Sadvik 8)Mylarapu Soujanya 9)Namburi Nireekshana 10)Jarapala Ramesh Babu
(31) Priority Document No	:NA	(72)Name of Inventor : 1)Dr. Raghu Chandra Garimella 2)Dr. Siva Rama Krishna Madeti 3)Dyava SaiBharath Krishna Reddy 4)Nattala Shiva Kumar 5)Butharaju Saidivya 6)Takkala Soumya 7)Chepuri Sadvik 8)Mylarapu Soujanya 9)Namburi Nireekshana 10)Jarapala Ramesh Babu
(32) Priority Date	:NA	
(33) Name of priority country	:NA	
(86) International Application No	:NA	
Filing Date	:NA	
(87) International Publication No	: NA	
(61) Patent of Addition to Application	:NA	
Number	:NA	
Filing Date	:NA	
(62) Divisional to Application Number	:NA	
Filing Date	:NA	

(57) Abstract :

In an embodiment of the present disclosure, Remote controlled air vehicle based sanitizing system with payload carrier (2400) is disclosed. The major advantage of present disclosure is to disinfect the larger surfaces and places where minimal human interference is expected, like covid-19 infected areas, isolation wards, public places, offices, educational institutions, factories etc. In the present disclosure, two (02) vacuum filled sanitizer can (2000) are used to disinfect the areas and controlled wirelessly through the data-sender (2100) unit. Further, the proposed system is capable of carrying a payload of about 15kg (like medicines, sanitizers, mini oxygen cylinders, etc.).

No. of Pages : 46 No. of Claims : 10

(54) Title of the invention : IOT BASED AUTOMATIC WATER CLARITY MEASUREMENT SYSTEM POWERED BY SOLAR CELLS

<p>(51) International classification</p> <p>(31) Priority Document No</p> <p>(32) Priority Date</p> <p>(33) Name of priority country</p> <p>(86) International Application No Filing Date</p> <p>(87) International Publication No</p> <p>(61) Patent of Addition to Application Number Filing Date</p> <p>(62) Divisional to Application Number Filing Date</p>	<p>:G01N0033180000, H05B0045100000, G01N0021590000, G01N0021530000, G01N0021310000</p> <p>:NA</p> <p>:NA</p> <p>:NA</p> <p>:NA</p> <p>:NA</p> <p>: NA</p> <p>:NA</p> <p>:NA</p> <p>:NA</p> <p>:NA</p>	<p>(71)Name of Applicant :</p> <p>1)Ms T D Subha Address of Applicant :Assistant Professor, Department of ECE, R.M.K. Engineering College, Kavaraipettai, Chennai, Tamil Nadu. Tamil Nadu India</p> <p>2)Mr T Joel</p> <p>3)Mr V Ramkumar</p> <p>4)Mr S P Vijaya Vardan Reddy</p> <p>5)Ms V Femina</p> <p>6)Ms K Dhivya</p> <p>7)Mr S Jai Ganesh</p> <p>8)Ms V Kannagi</p> <p>9)Mr K Naresh Kumar Thapa</p> <p>10)Dr P Ponmurugan</p> <p>(72)Name of Inventor :</p> <p>1)Ms T D Subha</p> <p>2)Mr T Joel</p> <p>3)Mr V Ramkumar</p> <p>4)Mr S P Vijaya Vardan Reddy</p> <p>5)Ms V Femina</p> <p>6)Ms K Dhivya</p> <p>7)Mr S Jai Ganesh</p> <p>8)Ms V Kannagi</p> <p>9)Mr K Naresh Kumar Thapa</p> <p>10)Dr P Ponmurugan</p>
--	---	---

(57) Abstract :

Water clarity is the most common indicator of water quality. The proposed innovation is an instrument which can automatically measure water clarity in place of manual measurement. The instrument is suspended by buoys at the water surface and uses solar energy to measure the light intensity of LED bulbs after passing through a water column; the result is then converted to Secchi depth by using a regression function. Measurement data are stored in a cloud server so that mobile users can access via an Internet connection. Three experiments were conducted to examine the instrument performance: (i) to ensure light intensity of the LED bulbs is strong enough to pass through the water column; (ii) to determine the regression relationship between the measured light intensity of the instrument and Secchi depth; and (iii) to evaluate the coefficient of variation (CV) of the measured water clarity.

No. of Pages : 11 No. of Claims : 7

(54) Title of the invention : SENSOR BASED SMART BELT

(51) International classification	:A61H0003060000, G09B0021000000, A41F0009000000, G01S0013880000, A62B0033000000	(71)Name of Applicant : 1)Mr. S. Palani Address of Applicant :Sri Krishna College of Engineering and Technology, Kuniyamuthur, Coimbatore. Tamilnadu, India. 641008. Tamil Nadu India 2)Dr. K. Ramesh Babu 3)Dr.J.Janet 4)Dr.V.Ragavi 5)Dr.S.Balakrishnan 6)Dr. G. Ignisha Rajathi 7)Mr. T .Vignesh
(31) Priority Document No	:NA	(72)Name of Inventor : 1)Mr. S. Palani 2)Dr. K. Ramesh Babu 3)Dr.J.Janet 4)Dr.V.Ragavi 5)Dr.S.Balakrishnan 6)Dr. G. Ignisha Rajathi 7)Mr. T .Vignesh
(32) Priority Date	:NA	
(33) Name of priority country	:NA	
(86) International Application No	:NA	
Filing Date	:NA	
(87) International Publication No	: NA	
(61) Patent of Addition to Application	:NA	
Number	:NA	
Filing Date	:NA	
(62) Divisional to Application Number	:NA	
Filing Date	:NA	

(57) Abstract :

In this digitized environmental survival, the technological warfare is an out-bursting criterion for the human survival. The varied techniques are growing in an avalanche pattern with very high impactful manner; it helps the human beings to survive easier. On the other hand, the visually impaired people suffering their day-to-day activities like walking on the road, getting things done in an orderly fashion etc. The solution for this problem is proposed by designing a Sensor Based Smart Belt • which can help the visually impaired person to walk safely without the help of others. It also identifies stagnated water, small pits and gives indications to him/her. The belt worn by the person, senses the obstacle in full length of all degree height of the person, up and down the belt worn by the person i.e., object on road side, person in full height, water on pathway. This also works with 2 modes as in-built and manual choice mode to pick a vibration or alarm or voice instruction to intimate the person with the hindrance in front of him. The sensor stick has features which senses the obstacles and informs the visually impaired about the hindrance within seconds on the pathway only. This technology totally differs from the sensor stick. It stands on top with certain features such as easy to handle, comfortable charging and adaptable designing.

No. of Pages : 6 No. of Claims : 3

(12) PATENT APPLICATION PUBLICATION

(21) Application No.202141020794 A

(19) INDIA

(22) Date of filing of Application :07/05/2021

(43) Publication Date : 11/06/2021

(54) Title of the invention : SUSTAINABLE TREE BASED SMART POWER GENERATION SYSTEM

(51) International classification	:F03D0009250000, H02S0010120000, F03D0009000000, F03D0001020000, F03D0013200000	(71)Name of Applicant : 1) Dr. V. S. ARULMURUGAN Address of Applicant :DEPARTMENT OF EEE, EXCEL COLLEGE OF ENGINEERING AND TECHNOLOGY, KOMARAPALAYAM, NAMAKKAL - 637303. Tamil Nadu India 2)Mr. S. SANKARANANTH 3)Ms. C. RAJESWARI 4)Mr. R. ARUNKUMAR 5)Mr. J. CHANDRAMOHAN 6)Dr. R. GANDHI 7)Dr. M. MALARVIZHI 8)Dr. N. NANDHAGOPAL
(31) Priority Document No	:NA	(72)Name of Inventor :
(32) Priority Date	:NA	1) Dr. V. S. ARULMURUGAN
(33) Name of priority country	:NA	2)Mr. S. SANKARANANTH
(86) International Application No	:NA	3)Ms. C. RAJESWARI
Filing Date	:NA	4)Mr. R. ARUNKUMAR
(87) International Publication No	: NA	5)Mr. J. CHANDRAMOHAN
(61) Patent of Addition to Application Number:	:NA	6)Dr. R. GANDHI
Filing Date	:NA	7)Dr. M. MALARVIZHI
(62) Divisional to Application Number	:NA	8)Dr. N. NANDHAGOPAL
Filing Date	:NA	

(57) Abstract :

An apparatus for generating electrical power. The apparatus comprises of a sustainable energy generator from the natural resources: sun and wind. The apparatus comprises a plurality of solar energy collectors for generating electricity from solar energy; a plurality of wind turbines for generating electricity from wind energy; a support structure having arms extending radially from a vertical shaft; wind turbines surrounded with solar panels are affixed to the arms; and the support structure comprising solar and wind power generators resembles a tree structure not affecting the beauty of nature and vegetation. The power generator is eco-friendly and produce noise-free and carbon-free power for the beneficial of the residential and commercial areas that are not suitable for the construction of traditional wind turbines.

No. of Pages : 21 No. of Claims : 10

(12) PATENT APPLICATION PUBLICATION

(21) Application No.202141020823 A

(19) INDIA

(22) Date of filing of Application :07/05/2021

(43) Publication Date : 11/06/2021

(54) Title of the invention : SYSTEM FOR MENTAL HEALTH DETECTION THROUGH TEXTEMOJI COMMUNICATION AND INTERNET ACTIVITIES USING MACHINE LEARNING

(51) International classification	:G06N0020000000, G16H0050300000, G06N0003080000, G16H0020700000, G06F0009480000	(71)Name of Applicant : 1)Dr. Suhan Address of Applicant :Associate Professor, Manipal Institute of Management, Manipal Academy of Higher Education, Manipal, Karnataka, India Karnataka India 2)Dr. Smitha Nayak 3)Dr.Ramya Shenoy 4)Dr. Sara Kunnath 5)Dr.Vishal Samartha 6)Dr. Ananth Prabhu G 7)Sujaya H
(31) Priority Document No	:NA	(72)Name of Inventor : 1)Dr. Suhan 2)Dr. Smitha Nayak 3)Dr.Ramya Shenoy 4)Dr. Sara Kunnath 5)Dr.Vishal Samartha 6)Dr. Ananth Prabhu G 7)Sujaya H
(32) Priority Date	:NA	
(33) Name of priority country	:NA	
(86) International Application No	:NA	
Filing Date	:NA	
(87) International Publication No	: NA	
(61) Patent of Addition to Application	:NA	
Number	:NA	
Filing Date	:NA	
(62) Divisional to Application Number	:NA	
Filing Date	:NA	

(57) Abstract :

The present invention relates to system for mental health detection through textemoji communication and internet activities using machine learning. The objective of the present invention is to solve the problems in the prior art technologies related to mental illness detection using the internet activities.

No. of Pages : 30 No. of Claims : 6

(12) PATENT APPLICATION PUBLICATION

(21) Application No.202141020845 A

(19) INDIA

(22) Date of filing of Application :07/05/2021

(43) Publication Date : 11/06/2021

(54) Title of the invention : SYSTEM AND DEVICE FACILITATING PURIFICATION MONITORING AND PREDICTION OF FILTERED WATER QUALITY

(51) International classification	:C02F0001000000, C02F0009000000, C02F0001440000, G01N0033180000, C02F0001280000	(71) Name of Applicant : 1)Lustral Innovations Private Limited Address of Applicant :2 - C, Callundalla Block Regency, La Majada App Hennur Main Road, Bangalore - 560043, Karnataka, India. Karnataka India
(31) Priority Document No	:NA	(72) Name of Inventor :
(32) Priority Date	:NA	1)PATNAIK, Aditya
(33) Name of priority country	:NA	2)NAVADA, Shreyas V
(86) International Application No	:NA	
Filing Date	:NA	
(87) International Publication No	: NA	
(61) Patent of Addition to Application Number	:NA	
Filing Date	:NA	
(62) Divisional to Application Number	:NA	
Filing Date	:NA	

(57) Abstract :

The present disclosure relates generally to a water purification system. The water purification system is an IoT based AI enabled water purifier integrated with ultrafiltration, ultraviolet unit and a mineralizer. The water purification system tracks a TDS, pH score, filtration candles quality, auto water spillage detection, total water consumption, turbidity, total water quality and the like. The AI enabled system may further predict daily water consumption and may prevent wastage of water by determining the average water required for drinking and cooking by one or more users.

No. of Pages : 54 No. of Claims : 10

(12) PATENT APPLICATION PUBLICATION

(21) Application No.202141020875 A

(19) INDIA

(22) Date of filing of Application :07/05/2021

(43) Publication Date : 11/06/2021

(54) Title of the invention : NANO PHOTO DIODE ARRAY (NPDA) FOR SUBRETINAL IMPLANT

(51) International classification	:A61N0001050000, A61B0003120000, A61F0002140000, H01L0027144000, A61K0038050000	(71) Name of Applicant : 1)Mr. Vijai Meyappan Address of Applicant :Assistant Professor, Department of Electronics and Communication Engineering, M.I.E.T Engineering college, Trichy-620007, Tamilnadu, India Tamil Nadu India
(31) Priority Document No	:NA	2)Dr. Joseph Daniel R
(32) Priority Date	:NA	(72) Name of Inventor :
(33) Name of priority country	:NA	1)Mr. Vijai Meyappan
(86) International Application No	:NA	2)Dr. Joseph Daniel R
Filing Date	:NA	
(87) International Publication No	: NA	
(61) Patent of Addition to Application Number	:NA	
Filing Date	:NA	
(62) Divisional to Application Number	:NA	
Filing Date	:NA	

(57) Abstract :

The developing country like India is still starving for the improvement in health sector. The age associated Macula degeneration and Retinitis Pigmentosa are the major diseases that particularly affect the elderly people around the world. This work aimed to improve the photo sensing devices that helps to bring back the vision. This invention provides an organic based artificial retina device (Nano photodiode array) that includes carbon nano tube and graphene. This nanomaterial generate electrical pulses under incident light, this helps to stimulate the photoreceptor cells in the retina this helps the restoration of vision those who has retinal problems. Although the chosen nanomaterial complexes is biocompatible and improved electrical performance when compared to other nano blend. Overall this nano complex is a good candidate for sub retinal implants.

No. of Pages : 29 No. of Claims : 8

(54) Title of the invention : Graphical, Hierarchical and Orthogonal Maximum Power Point Tracking Statecharts for Photovoltaic System

(51) International classification	:G05F0001670000, H02J0003380000, G06F0119060000, G06F0030330000, G05B0017020000	(71)Name of Applicant : 1)Dr. Rama Sudha Kasibhatla Address of Applicant :Professor, Department of Electrical Engineering, AU College of Engineering (A), Andhra University, Visakhapatnam, Andhra Pradesh-, India. Andhra Pradesh India
(31) Priority Document No	:NA	2)Dr. Vijaya Santhi Rajamahanthi
(32) Priority Date	:NA	3)Ms. Venkat Pankaj Lahari Molleti
(33) Name of priority country	:NA	4)Dr. Chandra Sekhar Akkapeddi
(86) International Application No	:PCT//	(72)Name of Inventor :
Filing Date	:01/01/1900	1)Dr. Rama Sudha Kasibhatla
(87) International Publication No	: NA	2)Dr. Vijaya Santhi Rajamahanthi
(61) Patent of Addition to Application Number:	:NA	3)Ms. Venkat Pankaj Lahari Molleti
Filing Date	:NA	4)Dr. Chandra Sekhar Akkapeddi
(62) Divisional to Application Number	:NA	
Filing Date	:NA	

(57) Abstract :

Exemplary aspects of the present disclosure are directed towards the design and development of Graphical, Hierarchical and Orthogonal Maximum Power Point Tracking Statecharts for Photovoltaic System. The primary motivation for this invention arises from the fact that integrated PV systems demand MPP tracking speeds in orders of sub- milliseconds. Among the many available MPPT algorithms, the most widely used are Perturb & Observe (P&O) and Incremental conductance (Inc-Con) algorithms, for which statechart-MPPT controller models are developed in this invention. These graphical statechart-MPPT controllers achieved tracking speeds in orders of sub-milliseconds (as low as 0.11ms), under varying irradiance and load conditions in the PV system. Graphical P&O Statechart-MPPT controller(Fig.100) is modelled, designed and deployed in target embedded controller, along with the incorporation of hierarchy. All transition codes and state-action codes are defined appropriately (Fig. 200). Hierarchy is an essential feature of the developed statechart-MPPT controllers, which improves abstraction in the controller model as well as readability. It also reduces the overall required number of transitions in the design. Graphical Inc-con Statechart-MPPT controller(Fig.300) is modelled, designed and deployed in target embedded controller, and incorporates hierarchy and orthogonality. All transition codes and state-action codes are defined appropriately (Fig. 400). Hierarchy is an essential feature of the developed statechart-MPPT controllers, which allows the system to be active in more than one subsystem simultaneously. This allows parallel or concurrent monitoring of various subsystems in the overall system, without hampering the execution and tracking speeds of the MPPT controller of the PV system.

No. of Pages : 15 No. of Claims : 6

(12) PATENT APPLICATION PUBLICATION

(21) Application No.202141020891 A

(19) INDIA

(22) Date of filing of Application :07/05/2021

(43) Publication Date : 11/06/2021

(54) Title of the invention : INTELLIGENT SMART MONITORING SYSTEM FOR EARLY DETECTION OF DIABETIC FOOT ULCER

(51) International classification	:A61B0005000000, G16H0050300000, A61B0005026000, A61K0036280000, A61B0005010000	(71)Name of Applicant : 1)Dr. A. Sivagami Address of Applicant :Associate Professor, Institute of Electronics and communication Engineering Saveetha School of Engineering, SIMATS, Chennai 602 105 Tamilnadu Tamil Nadu India 2)Dr. Annie Grace Vimala 3)Dr. K. Michael Angelo 4)Dr. A. Raja 5)Dr. Bhaskarrao Yakkala 6)Mr. Vijai Meyappan 7)Dr. Gowrishankar.K 8)Dr. K. Baskaran 9)Dr. Kiran George
(31) Priority Document No	:NA	(72)Name of Inventor : 1)Dr. A. Sivagami 2)Dr. Annie Grace Vimala 3)Dr. K. Michael Angelo 4)Dr. A. Raja 5)Dr. Bhaskarrao Yakkala 6)Mr. Vijai Meyappan 7)Dr. Gowrishankar.K 8)Dr. K. Baskaran 9)Dr. Kiran George
(32) Priority Date	:NA	
(33) Name of priority country	:NA	
(86) International Application No	:NA	
Filing Date	:NA	
(87) International Publication No	: NA	
(61) Patent of Addition to Application Number	:NA	
Filing Date	:NA	
(62) Divisional to Application Number	:NA	
Filing Date	:NA	

(57) Abstract :

Diabetic Mellitus is a chronic disease that causes serious health problems, which gradually lead to severe vascular problems and nerve damages. That problem leads to an increase in the chances of foot ulcers prolong to even lower leg amputation. The diabetic cases are significantly increasing over the years in the world. However still diabetes is a major challenge for researchers, though many cases occur of that the diabetic foot ulcer (DFU) is one of the critical factors. But still, they fail to monitor the blood flow level, the temperature of the skin, humidity, and most important parameter that forces acting on pressure points. But this continuous monitoring may help the physician to identify or early detection of foot ulcer formation in the patients. Therefore in this invention, we propose an intelligent monitoring system based on continuous monitoring of the above-mentioned parameters. This system measures the value and process of the parameter within the module. Further, this module is connected with patient mobile or gadgets through IoT, this helps for store complete record of that foot forces on pressure point values, Temperature & humidity information. By merely viewing the graphical information the physician can easily provide treatment for the foot ulcer prone areas or high-pressure point. This processing time taken is really reduced and it is an added advantage for the patients who need not waiting for a long time for the results. This invention helps to improve the quality of life for type1 diabetes mellitus patients.

No. of Pages : 31 No. of Claims : 6

(12) PATENT APPLICATION PUBLICATION

(21) Application No.202141020912 A

(19) INDIA

(22) Date of filing of Application :08/05/2021

(43) Publication Date : 11/06/2021

(54) Title of the invention : AUTOMATED SEWAGE CHANNEL BLOCKAGE DETECTION SYSTEM AND METHODS OF INFORMING THEREOF

(51) International classification	:H04W0084180000, G08C0017020000, G08B0025100000, F17D0005020000, G01N0021330000	(71) Name of Applicant : 1)Vergin Raja Sarobin M Address of Applicant :Assistant Professor Senior School of Computer Science and Engineering, Vellore Institute of Technology, Chennai Tamil Nadu India 2)Jani Anbarasi L 3)Yasashvini R 4)Berin Shalu S 5)Modigari Narendra 6)Dhanya D
(31) Priority Document No	:NA	(72) Name of Inventor :
(32) Priority Date	:NA	1)Vergin Raja Sarobin M
(33) Name of priority country	:NA	2)Jani Anbarasi L
(86) International Application No	:NA	3)Yasashvini R
Filing Date	:NA	4)Berin Shalu S
(87) International Publication No	: NA	5)Modigari Narendra
(61) Patent of Addition to Application	:NA	6)Dhanya D
Number	:NA	
Filing Date	:NA	
(62) Divisional to Application Number	:NA	
Filing Date	:NA	

(57) Abstract :

The present invention herein relates to an automated sewage channel blockage detection system, more particularly a stand-alone module to detect the water level and concentration of gaseous substances inside the sewage channel, more particularly a networked alarming system to inform the occurrence of blockage with location information, in real-time efficiently, comprises a plurality of wireless sensor node [200], said each wireless sensor node, comprises a central computational unit [201], an ultrasonic sensor [202], a flow sensor [203], a wifi module [204], a battery unit [205], a gas sensor [206], a global positioning system [207], and a global system for mobile communication [208] module. Said wireless sensor node [200] in a larger number deployed throughout a sewage channel/pipeline [100] inside to measure sewage flow and level along with the concentration of harmful gas for an instance methane. FIGURE 1

No. of Pages : 16 No. of Claims : 10

(54) Title of the invention : Microwave-Hydrothermal synthesis of BaTiO₃ + NiCuZnFe₂O₄ nanocomposites

<p>(51) International classification :B82Y0030000000, H01F0001340000, C04B0035260000, C01G0049000000, B82Y0040000000</p> <p>(31) Priority Document No :NA (32) Priority Date :NA (33) Name of priority country :NA (86) International Application No :PCT// Filing Date :01/01/1900 (87) International Publication No : NA (61) Patent of Addition to Application Number :NA Filing Date :NA (62) Divisional to Application Number :NA Filing Date :NA</p>	<p>(71)Name of Applicant :</p> <p>1)Dr. Sadhana Katlakunta,Assistant Professor/Department of Physics, University College of Science Address of Applicant :University College of Science, Osmania University, Saifabad, Hyderabad, Telangana-500004 Telangana India</p> <p>2)Gaddameedi Sriramulu, Assistant Professor/Department of Physics, University College of Science</p> <p>3)P. Neeraja, Assistant Professor/Department of Physics, University College of Science</p> <p>4)N. Maramu, Assistant Professor/Department of Physics, Kakatiya Institute of Technology and Science.</p> <p>5)Dr. B. Ravinder Reddy,Assistant Professor/Department of Physics, University College of Science</p> <p>6)G. Padmasree, Associate Professor/ Department of Humanities & Sciences, Stanley College of Engineering and Technology for Women</p> <p>(72)Name of Inventor :</p> <p>1)Dr. Sadhana Katlakunta,Assistant Professor/Department of Physics, University College of Science</p> <p>2)Gaddameedi Sriramulu, Assistant Professor/Department of Physics, University College of Science</p> <p>3)P. Neeraja, Assistant Professor/Department of Physics, University College of Science</p> <p>4)N. Maramu, Assistant Professor/Department of Physics, Kakatiya Institute of Technology and Science.</p> <p>5)Dr. B. Ravinder Reddy,Assistant Professor/Department of Physics, University College of Science</p> <p>6)G. Padmasree, Associate Professor/ Department of Humanities & Sciences, Stanley College of Engineering and Technology for Women</p>
--	---

(57) Abstract :

Abstract The nano-sized BaTiO₃ and NiCuZn ferrite powders were synthesized using Microwave-Hydrothermal (M-H) system at 160—C/45 min. The ferroelectric and ferrite phases were confirmed by the XRD and surface morphologies were studied by SEM and TEM. The size of the powders that were synthesized using M-H system was found to be 4060 nm. The xBaTiO₃ + (1 - x) NiCuZnFe₂O₄ nano-composites were prepared at different weight percentages. The room temperature hysteresis loops were taken on the present composite samples in the field of 5 kOe. The value of coercivity and saturation magnetization was found to be increasing with the decrease of BaTiO₃ content in the composites. The frequency variation dielectric constant ($\hat{\mu}$), dissipation factor (D), initial permeability (μ_i) and quality factor (Q) were studied at room temperature in the frequency range of 1 kHz 1 MHz region. From these studies it was observed that the present composites were useful for the fabrication of Multilayer Chip Inductors (MLCI).

No. of Pages : 17 No. of Claims : 5

(12) PATENT APPLICATION PUBLICATION

(21) Application No.202141020953 A

(19) INDIA

(22) Date of filing of Application :08/05/2021

(43) Publication Date : 11/06/2021

(54) Title of the invention : IMPROVED MAGNETIC PROPERTIES OF CR3+ DOPED SRFE12O19 SYNTHESIZED VIA MICROWAVE HYDROTHERMAL ROUTE

(51) International classification	:H01F0041020000, H01S0003160000, C04B0035626000, B22F0009220000, C03C0004000000	(71) Name of Applicant : 1)Dr. Sadhana Katlakunta,Assistant Professor/Department of Physics, University College of Science. Address of Applicant :University College of Science, Osmania University, Saifabad, Hyderabad, Telangana-500004. Telangana India
(31) Priority Document No	:NA	(72) Name of Inventor :
(32) Priority Date	:NA	1)Dr. Sadhana Katlakunta,Assistant Professor/Department of Physics, University College of Science.
(33) Name of priority country	:NA	
(86) International Application No	:NA	
Filing Date	:NA	
(87) International Publication No	: NA	
(61) Patent of Addition to Application Number:	NA	
Filing Date	:NA	
(62) Divisional to Application Number	:NA	
Filing Date	:NA	

(57) Abstract :

Abstract Cr doped Sr-hexaferrites (SrCr_xFe_{12-x}O₁₉) were prepared using microwave-hydrothermal method and sintered at 950°C/90 min using single mode microwave furnace. With increasing Cr³⁺ content, the lattice parameters changed anisotropically, where \tilde{a}^{TM} increases and \tilde{c}^{TM} decreases. The average grain sizes of sintered hexaferrite are in the range of 280660 nm. XPS spectra shows that for higher Cr³⁺ content i.e., $x > 0.3$, both Fe²⁺ and Fe³⁺ ions are present in the crystal structure. With Cr³⁺ doping saturation magnetization systematically decreased and coercivity increased. Magnetic hyperfine analysis using Mossbauer technique indicates that Cr³⁺ ions preferentially occupy 2a, 12k, and 4f₁ sites.

No. of Pages : 21 No. of Claims : 4

(12) PATENT APPLICATION PUBLICATION

(21) Application No.202141020956 A

(19) INDIA

(22) Date of filing of Application :08/05/2021

(43) Publication Date : 11/06/2021

(54) Title of the invention : A Compact Metamaterial integrated slot patch Penta-band Antenna For Wi-MAX, WLAN, Satellite band and X-band Applications

(51) International classification	:H01Q0009040000, H01Q0001480000, H01Q0001500000, H01Q0001380000, H03F0001560000	(71) Name of Applicant : 1)P.Ezekiel julian Address of Applicant :School of ECE, REVA University Rukmini Knowledge Park, Kattigenahalli, Yelahanka, Bengaluru, Karnataka 560064 Karnataka India
(31) Priority Document No	:NA	2)Vinay D
(32) Priority Date	:NA	3)Pramod kumar
(33) Name of priority country	:NA	4)Muyisa Wasukundi
(86) International Application No	:PCT//	5)Ravikumar M G
Filing Date	:01/01/1900	6)SUBHASH B K
(87) International Publication No	: NA	(72) Name of Inventor :
(61) Patent of Addition to Application Number	:NA	1)P.Ezekiel julian
Filing Date	:NA	2)Vinay D
(62) Divisional to Application Number	:NA	3)Pramod kumar
Filing Date	:NA	4)Muyisa Wasukundi
		5)Ravikumar M G
		6)SUBHASH B K

(57) Abstract :

A penta band loaded with complementary octagonal split ring resonator (COSRR) is reported. The antenna has a size of $0.16\lambda \times 0.16\lambda$, at lower frequency band of 3.33 GHz. The antenna consists of a rectangular slot is placed in the ground plane and complementary octagonal split ring resonator in the radiating patch, which independently resonates lower frequency at 3.33 GHz and other four bands at 5.01GHz, 5.28GHz, 7.46GHz, and 9.48GHz respectively. It is observed that the proposed structure is having better impedance matching, gain, efficiency and stable radiation pattern at targeted frequencies and used for Wi-MAX, WLAN, Satellite band and X-band applications.

No. of Pages : 14 No. of Claims : 3

(12) PATENT APPLICATION PUBLICATION

(21) Application No.202141020964 A

(19) INDIA

(22) Date of filing of Application :09/05/2021

(43) Publication Date : 11/06/2021

(54) Title of the invention : TILED SOLAR DISTILLATION SYSTEM

<p>(51) International classification :C02F0001140000, C02F0001180000, B01D0005000000, B01D0001000000, F24S0010600000</p> <p>(31) Priority Document No :NA</p> <p>(32) Priority Date :NA</p> <p>(33) Name of priority country :NA</p> <p>(86) International Application No :NA</p> <p>Filing Date :NA</p> <p>(87) International Publication No : NA</p> <p>(61) Patent of Addition to Application Number :NA</p> <p>Filing Date :NA</p> <p>(62) Divisional to Application Number :NA</p> <p>Filing Date :NA</p>	<p>(71)Name of Applicant :</p> <p>1)Dr.S.Joe Patrick Gnanaraj Address of Applicant :Associate Professor Department of Mechanical Engineering Francis Xavier engineering college Tirunelveli. Tamil Nadu India</p> <p>2)Dr.Zeenathul Farida Abdul Gani, Francis Xavier engineering college</p> <p>3)Dr.M.Appadurai, Dr. Sivanthi Aditanar college of Engineering</p> <p>4)Mr.M.Muthu Kumar, Kalasalingam Academy of Research and Education</p> <p>5)Dr.M.Jinnah Sheik Mohamed, University of Technology and Applied sciences -Shinas</p> <p>6)A. Kandasamy, Francis Xavier Engineering College</p> <p>7)Dr.K.Athiappan, Jyothi Engineering College</p> <p>8)K.S.Maheswari, Kalasalingam Academy of Research and Education</p> <p>9)I. Syed Abjimiah, Francis Xavier Engineering College</p> <p>10)Dr.S.Nagarajan, Tisaiyanvilai</p> <p>11)Dr. V.Kannan, Thoothukudi</p> <p>(72)Name of Inventor :</p> <p>1)Dr S Ramachandran, CMR Institute of Technology</p> <p>2)Dr.V.Kannan, Thoothukudi</p> <p>3)Dr.S.Joe Patrick Gnanaraj, FXEC</p> <p>4)Dr.M.Jinnah Sheik Mohamed, University of Technology and Applied sciences -Shinas</p> <p>5)A. Kandasamy, FXEC</p> <p>6)P. LEELA JANCY, Sri Sai Ram Institute of Technology</p> <p>7)Dr.K.Athiappan, Jyothi Engineering College</p> <p>8)K.S.Maheswari, Kalasalingam Academy of Research and Education</p> <p>9)M.MUTHU KUMAR, Kalasalingam Academy of Research and Education</p> <p>10)LSYED ABJIMIAH, FXEC</p> <p>11)Dr.S.Nagarajan, Tisayanvilai</p> <p>12)Dr.M.Appadurai, Dr. Sivanthi Aditanar college of Engineering</p>
--	--

(57) Abstract :

The invention is about a solar still made up of tiles that is used to produce pure drinking water by means of distillation process. Generally, the output or yield of solar still (i.e. the pure palatable water) received, depends upon number of factors, namely material of lid, color of tank/sink base, etc. Hence, a still is fabricated in a manner such that a square basin is surrounded by alternate rectangular and triangular stills so as to collect the distilled water effectively. Each still are divided into chambers where solar energy can be obtained. The basin and the arms are covered by any material and they are inclined at a particular angle to obtain better distillate water. The average amount of distillate produced through this process is 18950 ml/per day. This entire solar still is scalable as per the users need.

No. of Pages : 16 No. of Claims : 5

(12) PATENT APPLICATION PUBLICATION

(21) Application No.202141020965 A

(19) INDIA

(22) Date of filing of Application :09/05/2021

(43) Publication Date : 11/06/2021

(54) Title of the invention : VIRTUAL MOM RESPONSIVE BABY MONITORING TOY

(51) International classification	:G08B0021020000, A63H0033000000, G06N0005040000, G06N0020000000, G09B0019000000	(71)Name of Applicant : 1)VNR VIGNANA JYOTHI INSTITUTE OF ENGINEERING AND TECHNOLOGY Address of Applicant :Vignana Jyothi Nagar, Pragathi Nagar, Nizampet (S.O), Hyderabad, Telangana, 500 090, India Telangana India
(31) Priority Document No	:NA	(72)Name of Inventor :
(32) Priority Date	:NA	1)V. BABY
(33) Name of priority country	:NA	2)Dr. S. NAGINI
(86) International Application No	:NA	3)K. JHANSI LAKSMI BAI
Filing Date	:NA	4)Dr. SAGAR YERUVA
(87) International Publication No	: NA	5)G. YASHWANTH
(61) Patent of Addition to Application Number	:NA	6)B. JANAKI RAM
Filing Date	:NA	7)A. RIKHILA
(62) Divisional to Application Number	:NA	8)Dr. D. N. VASUNDHARA
Filing Date	:NA	9)N. V. SAILAJA
		10)A. MADHAVI

(57) Abstract :

ABSTRACT VIRTUAL MOM RESPONSIVE BABY MONITORING TOY • The virtual mom is a responsive baby monitoring toy used to reduce the stress on working mothers. As working mothers find it tedious to manage both work and taking care of the baby, this toy helps them monitor the baby when they're at work. It's a smart toy, equipped with sensors to track different movements /actions of the baby/infant. Trained Deep Learning models and some sensor data help in interpreting the movements/actions of the baby. The inferences made by the sensors are sent to a server through Wi-Fi, from where the mobile application can access and display them. The mobile application acts as the two-way communicator which conveys the moods and actions of the baby to the mother and then returns the chosen style of response from the mother to the toy. The toy provides a provision for the mother to either speak to the baby or play pre-recorded audio clips or play music which makes the baby feel relaxed. The response received from the mother's end is then processed and the toy performs the required action to calm the baby. When the mother is at work, she can observe the kidTMs activities. Some working parents employ babysitters and caretakers to take care of their children while theyTMre away. Sometimes these caretakers donTMt perform their duty genuinely and using this toy, parents can also monitor how the caretakers are behaving with the child. The mother can also send a response whenever she wants to talk and engage the baby, hence making virtual parenting possible, and successful. Fig.2. Circuit Diagram

No. of Pages : 10 No. of Claims : 6

(12) PATENT APPLICATION PUBLICATION

(21) Application No.202141020966 A

(19) INDIA

(22) Date of filing of Application :09/05/2021

(43) Publication Date : 11/06/2021

(54) Title of the invention : AEROSOL USING INTERNET OF THINGS

(51) International classification	:A61M0015000000, G06Q0050220000, A61K0009000000, A61M0011000000, A61J0007040000	(71) Name of Applicant : 1)Dr.K.SREELATHA Address of Applicant :St. PETERS ENGINEERING COLLEGE (A), OPP. TS FOREST ACADEMY DULLAPALLY, MAISAMMAGUDA, MEDCHAL, HYDERABAD, TELANGANA - 500043. Telangana India
(31) Priority Document No	:NA	2)Dr.DIANA MOSES
(32) Priority Date	:NA	3)Dr.A.ANJIAIAH
(33) Name of priority country	:NA	(72) Name of Inventor :
(86) International Application No	:NA	1)Dr.A.ANJIAIAH
Filing Date	:NA	2)Dr.K.SREELATHA
(87) International Publication No	: NA	3)S.MEGHANA
(61) Patent of Addition to Application	:NA	4)M.AKANKSHA
Number	:NA	5)P.SHIVANI
Filing Date	:NA	
(62) Divisional to Application Number	:NA	
Filing Date	:NA	

(57) Abstract :

Aerosol using the internet of things aims at implementing and designing a smart inhaler that provides a measure and aerosolized dose of a wide assortment of medication that is administered to the lungs and air pathways the key feature of the IoT based Smart inhaler is that it helps the patients adhere to their medication routine, and also allows the physicians to monitor their patients remotely. The smart asthma inhaler precisely archives usage- when each dose is taken, it transfers this status to doctors and helps keep the illnesses in check. This technology also gives automatically generated reminders, through the app, informing the patient to use the inhaler whenever necessary.

No. of Pages : 27 No. of Claims : 6

(12) PATENT APPLICATION PUBLICATION

(21) Application No.202141020971 A

(19) INDIA

(22) Date of filing of Application :09/05/2021

(43) Publication Date : 11/06/2021

(54) Title of the invention : OBSTACLE DETECTOR FOR VISUALLY IMPAIRED PEOPLE

(51) International classification	:A61H0003060000, G09B0021000000, G08G0001160000, G01S0015931000, A61F0009080000	(71) Name of Applicant : 1)Dr.K.SREELATHA Address of Applicant :St. PETERS ENGINEERING COLLEGE (A), OPP. TS FOREST ACADEMY DULLAPALLY, MAISAMMAGUDA, MEDCHAL, HYDERABAD, TELANGANA - 500043. Telangana India
(31) Priority Document No	:NA	2)Dr.A.ANJIAH
(32) Priority Date	:NA	3)Dr.DIANA MOSES
(33) Name of priority country	:NA	(72) Name of Inventor :
(86) International Application No	:NA	1)Dr.K.SREELATHA
Filing Date	:NA	2)Dr.DIANA MOSES
(87) International Publication No	: NA	3)Dr.A.ANJIAH
(61) Patent of Addition to Application	:NA	4)B.VAISHNAVI
Number	:NA	5)D.VENU
Filing Date	:NA	6)M.SHALAKA
(62) Divisional to Application Number	:NA	
Filing Date	:NA	

(57) Abstract :

Obstacle detection and warning can improve the mobility as well as the safety of visually impaired people, especially in unfamiliar environments. For this, firstly, obstacles are detected and localized and then the information of the obstacles will be sent to the visually impaired people by using different modalities such as voice, tactile, vibration. Earlier navigation systems were expensive and time-consuming when used in day-to-day life. Our proposed system uses an ultrasonic sensor to detect the obstacles and processes them using a microcontroller which is of an affordable cost. Once the obstacle is detected, the distance is calculated at which the obstacle is located and warns the user according to the range in which the obstacle is present. The proposed system aims at developing a cost-effective system, therefore, increasing the feasibility for the visually impaired people to walk by themselves in almost all environments.

No. of Pages : 22 No. of Claims : 5

(12) PATENT APPLICATION PUBLICATION

(21) Application No.202141020988 A

(19) INDIA

(22) Date of filing of Application :10/05/2021

(43) Publication Date : 11/06/2021

(54) Title of the invention : IOT DRIVEN SMART PISCICULTURE MONITORING AND CONTROL SYSTEM

(51) International classification	:G07C0009000000, A01K0063040000, H04L0029080000, B01D0053840000, G01N0033180000	(71) Name of Applicant : 1)Polly Thomas Address of Applicant :Department of Electrical & Electronics Engineering SAINTGITS College of Engineering, Kottukulam Hills Pathamuttom P. O Kottayam 686532 KERALA Kerala India
(31) Priority Document No	:NA	2)Farah Fathima Raheem
(32) Priority Date	:NA	3)Sanju Joseph Abraham
(33) Name of priority country	:NA	4)Sidharth Sivanraj
(86) International Application No	:NA	5)Vaishnav Nair S
Filing Date	:NA	(72) Name of Inventor :
(87) International Publication No	: NA	1)Polly Thomas
(61) Patent of Addition to Application Number	:NA	2)Farah Fathima Raheem
Filing Date	:NA	3)Sanju Joseph Abraham
(62) Divisional to Application Number	:NA	4)Sidharth Sivanraj
Filing Date	:NA	5)Vaishnav Nair S

(57) Abstract :

Internet of Things (IoT) has now emerged as a governing trend in the electronics era with cloud services and remotely operable electronic systems dominating the ever-increasing electronics product segment. This has now paved the way for a new breed of farms with fully automated farming procedures and mechanized labor giving rise to greater yield and higher quality than previously thought possible. The proposed system aims at bringing the trend of automation to fish farming. This system based on a low cost energy efficient system is connected to multiple sensors allowing it to measure various water quality parameters such as temperature, pH, TDS, Ammonia, salinity, electrical conductivity, water level and light intensity. The proposed system also integrates the control of the various motors used in pisciculture. The proposed system is a 2 part system- it has a measuring part which measures all the values and sends it to a controller and a controller part which controls the various motors associated with the fish farm using relays. Real-time control and monitoring is made possible using a mobile app that allows the user to control and monitor the entire system from any part of the world.

No. of Pages : 17 No. of Claims : 5

(54) Title of the invention : CROWD DETECTION CAMERA TO SPEKE THE MAINTAIN AND IDENTIFY THE SUSPECT USING AI-BASED PROGRAMMING.

<p>(51) International classification</p> <p>(31) Priority Document No</p> <p>(32) Priority Date</p> <p>(33) Name of priority country</p> <p>(86) International Application No Filing Date</p> <p>(87) International Publication No</p> <p>(61) Patent of Addition to Application Number Filing Date</p> <p>(62) Divisional to Application Number Filing Date</p>	<p>:G06K0009000000, G06N0003000000, G06N0020000000, G06N0003040000, G06N0007020000</p> <p>:NA</p> <p>:NA</p> <p>:NA</p> <p>:NA</p> <p>:NA</p> <p>: NA</p> <p>:NA</p> <p>:NA</p> <p>:NA</p> <p>:NA</p>	<p>(71)Name of Applicant :</p> <p>1)K. Anusha (Assistant Professor) Address of Applicant :Dept. of CSE, Geethanjali College of Engineering and Technology, Hyderabad, Telangana 501301, India. E-mail: anushareddy.kallem@gmail.com Telangana India</p> <p>2)G Swapna (Assistant Professor)</p> <p>3)Botla Mamatha (Assistant Professor)</p> <p>4)P. Harish (Assistant Professor)</p> <p>5)Dr. K. Suneetha (Professor)</p> <p>6)Dr. C. Sushama (Associate Professor)</p> <p>7)Dr. K. Venkata Nagendra (Associate Professor)</p> <p>8)P. Yogendra Prasad (Assistant Professor)</p> <p>9)Dr. Manmohan Singhal</p> <p>10)Dr. M. Sunil Kumar (Professor)</p> <p>(72)Name of Inventor :</p> <p>1)K. Anusha (Assistant Professor)</p> <p>2)G Swapna (Assistant Professor)</p> <p>3)Botla Mamatha (Assistant Professor)</p> <p>4)P. Harish (Assistant Professor)</p> <p>5)Dr. K. Suneetha (Professor)</p> <p>6)Dr. C. Sushama (Associate Professor)</p> <p>7)Dr. K. Venkata Nagendra (Associate Professor)</p> <p>8)P. Yogendra Prasad (Assistant Professor)</p> <p>9)Dr. Manmohan Singhal</p> <p>10)Dr. M. Sunil Kumar (Professor)</p>
--	---	--

(57) Abstract :

ABSTRACT Our Invention Crowd Detection Camera to Speke the Maintain and Identify the Suspect Using AI-Based Programming is an advanced computer-implemented method, computer program for detecting anomalous human behavior of advanced computing devices are real-time provided. The Invention is also a method of creating human artificial intelligence in machines and computer software is presented here as well as methods to simulate human reasoning thought and behavior and also the invention serves as a universal artificial intelligence program that will store, retrieve, analyze, assimilate, predict the future and modify information in a manner and fashion which is similar to human beings and which will provide users with a software application that will serve as the main intelligence of one or a multitude of computer based programs, software applications, machines or compilation of machinery. The invention is to a Smart appliance with built-in cameras, such as the Nest Cam and Amazon Echo Look, are becoming pervasive and also a they hold the promise of bringing high fidelity, contextually rich sensing into our homes, workplaces and other environments. Despite recent and impressive advances, computer vision systems are still limited in the types of sensing questions they can answer, and more importantly, do not easily generalize across diverse human environments and also a in response, researchers have investigated hybrid crowd- and AI-powered methods that collect human labels to bootstrap automatic processes.

No. of Pages : 16 No. of Claims : 6

(12) PATENT APPLICATION PUBLICATION

(21) Application No.202141020991 A

(19) INDIA

(22) Date of filing of Application :10/05/2021

(43) Publication Date : 11/06/2021

(54) Title of the invention : INNOVATIVE APPROACHES FOR EFFECTIVE MANAGERIAL COMPETENCY DEVELOPMENT (MCD) ADOPTED BY SIVA SIVANI INSTITUTE OF MANAGEMENT (SSIM)

(51) International classification	:G06Q0010060000, G06Q0010000000, G09B0007020000, G06Q0030000000, G06F0040470000	(71) Name of Applicant : 1)Siva Sivani Institute of Management Address of Applicant :NH-44 Kompally Secenderabad Telangana India - 500100 Telangana India
(31) Priority Document No	:NA	(72) Name of Inventor :
(32) Priority Date	:NA	1)Smt. Aarathy Sampathy, President & Chief Executive Officer/ SSIM
(33) Name of priority country	:NA	2)Dr. Sailesh Sampathy, Vice President & Deputy Chief Executive Officer/ SSIM
(86) International Application No	:NA	3)Mrs. Deepika Sampathy, Associate Vice President / SSIM
Filing Date	:NA	4)Dr. S.V. Ramana Rao, Director / SSIM
(87) International Publication No	: NA	5)Dr. N.C. Rajya Lakshmi, Professor / SSIM
(61) Patent of Addition to Application Number	:NA	
Filing Date	:NA	
(62) Divisional to Application Number	:NA	
Filing Date	:NA	

(57) Abstract :

Abstract The competency movement is gaining unmistakable momentum and popularity in Indian organizations. There is a lack of unanimity as to what is meant by the term ~competence™, due to the lack of consensus in efforts to define effective management. Apart from this, there is also an underlying uncertainty about the practicability of establishing generic managerial competencies. Most sets of management competencies • are developed without recognition of their inherent contradictions and without due regard to their conceptuality. The main aim of this work is to analyse the different competency studies done by SSIM so far and other research findings related to the methodology used in identifying managerial competencies. Second, this study also examines the extent to which there are competencies that are generic to professions, through Company Fact Presentation, Book Review, Industry review, Company review and Article Review Sessions and finally effective usage of OBE in MCD

No. of Pages : 11 No. of Claims : 5

(12) PATENT APPLICATION PUBLICATION

(21) Application No.202141021009 A

(19) INDIA

(22) Date of filing of Application :10/05/2021

(43) Publication Date : 11/06/2021

(54) Title of the invention : A BROILER BREEDER BIRDS FEED MANAGEMENT AND CONTROL SYSTEM AND METHOD THEREOF

(51) International classification	:H02J0050120000, A01K0039012000, A01K0005020000, A01K0039010000, H02J0050800000	(71) Name of Applicant : 1)GOWRISANKAR, Dr. T M. Address of Applicant :17, Sri Ram Avenue, Pappanaickenpalayam, Coimbatore, Tamil Nadu Tamil Nadu India
(31) Priority Document No	:NA	(72) Name of Inventor :
(32) Priority Date	:NA	1)BABU, C
(33) Name of priority country	:NA	
(86) International Application No	:NA	
Filing Date	:NA	
(87) International Publication No	: NA	
(61) Patent of Addition to Application Number	:NA	
Filing Date	:NA	
(62) Divisional to Application Number	:NA	
Filing Date	:NA	

(57) Abstract :

Disclosed herein an uniquely designed automatic systems and methods for accurate and precision feeding of the broiler breeder birds, wherein Feeding System comprising a Reciprocating Feeding module and wherein said Reciprocating Feeding module is moduled at lower and upper tiers of each row of the cages through a feed delivery pipe

No. of Pages : 19 No. of Claims : 15

(12) PATENT APPLICATION PUBLICATION

(21) Application No.202141021017 A

(19) INDIA

(22) Date of filing of Application :10/05/2021

(43) Publication Date : 11/06/2021

(54) Title of the invention : MOUTH MIRROR WITH RETRACTOR AND SUCTION HOLDER

(51) International classification	:A61B0017020000, A61C0017080000, A61C0005900000, A61C0017100000, A61B0013000000	(71) Name of Applicant : 1)VISHNU DENTAL COLLEGE Address of Applicant :VISHNUPUR, BHIMAVARAM WEST GODAVARI, ANDHRA PRADESH INDIA 534202 Andhra Pradesh India
(31) Priority Document No	:NA	(72) Name of Inventor :
(32) Priority Date	:NA	1)Dr. VILLA SAI SRUJANA
(33) Name of priority country	:NA	2)Dr. RAVIKANTH MANYAM
(86) International Application No	:NA	3)Dr. SURESH
Filing Date	:NA	SAJJANMUNGASAVALLICHANDRASHEKAR
(87) International Publication No	: NA	4)Dr.VENKATA RAMA RAJU ALLURI
(61) Patent of Addition to Application Number	:NA	
Filing Date	:NA	
(62) Divisional to Application Number	:NA	
Filing Date	:NA	

(57) Abstract :

APPLICANT: VISHNU DENTAL COLLEGE TITLE: MOUTH MIRROR WITH RETRACTOR AND SUCTION HOLDER
ABSTRACT The present invention discloses a multipurpose mouth mirror with retractor and suction holder to aid in simultaneous retraction, vision, and suction thereby helping dentist to work on patients easily even without chair side assistant in simple procedures. The multipurpose mouth mirror with retractor and suction holder of the present invention comprises of a rectangular handle with rounded edges for holding, integrated with a rectangular retractor component adapted to retract cheek and tongue, at a characterised angle of 110 degrees thereby forming a single unit characterised in slightly curved rectangular retractor component with convex side which is adapted to face towards mucosa for providing better movement of the retractor without causing any trauma and with slight tapering at end to prevent bony obstruction at posterior region along with serrations on back to attain grip in positioning a double-sided mouth mirror on centre of the retractor component at top by means of ball and socket joint through a connector in which the ball and socket employs magnet for extra holding force and prevents dislodgement of the mirror from the retraction component and inadvertent ingestion by making socket cover $\frac{3}{4}$ th of ball; in providing plurality of slots in the sockets for better sterilisation and provides space for movement of the connector to rotate the mirror in required direction and to position the mirror towards site of operation in positioning a suction holder on bottom of the retractor component after the angle, to hold a saliva ejector.

No. of Pages : 13 No. of Claims : 4

(12) PATENT APPLICATION PUBLICATION

(21) Application No.202141021018 A

(19) INDIA

(22) Date of filing of Application :10/05/2021

(43) Publication Date : 11/06/2021

(54) Title of the invention : DIAGNOSIS PREDICTION AND GRADCAM VISUALIZATION OF DENTAL OPGS WITH DEEP LEARNING AI MODEL

(51) International classification	:C12Q0001680900, G06Q0050200000, G16H0030400000, G16H0030200000, G06N0005040000	(71) Name of Applicant : 1)VISHNU DENTAL COLLEGE Address of Applicant :VISHNUPUR, BHIMAVARAM WEST GODAVARI, ANDHRA PRADESH INDIA 534202 Andhra Pradesh India
(31) Priority Document No	:NA	(72) Name of Inventor :
(32) Priority Date	:NA	1)VENKATA RAJESH KUMAR PETTA
(33) Name of priority country	:NA	2)DR SURESH SAJJAN MC
(86) International Application No	:NA	3)DR RAMARAJU A V
Filing Date	:NA	4)ABHINAV DAYAL
(87) International Publication No	: NA	
(61) Patent of Addition to Application Number	:NA	
Filing Date	:NA	
(62) Divisional to Application Number	:NA	
Filing Date	:NA	

(57) Abstract :

APPLICANT: VISHNU DENTAL COLLEGE TITLE: DIAGNOSIS PREDICTION AND GRADCAM VISUALIZATION OF DENTAL OPGS WITH DEEP LEARNING AI MODEL ABSTRACT The present invention discloses a method to predict diagnosis for multiple pathological conditions and GradCAM visualization of the predictions employing OPG images. The method of the present invention comprises of following sequential steps; a. receiving OPG image of a subject; b. submitting the OPG image to a characterized computing system for processing; c. obtaining from the characterized computing system prediction of positive as $\sim 1^{\text{TM}}$ or negative as $\sim 0^{\text{TM}}$ for each of 14 labeled pathological features and GradCAM visualization of each pathological feature predicted

No. of Pages : 15 No. of Claims : 3

(12) PATENT APPLICATION PUBLICATION

(21) Application No.202141021023 A

(19) INDIA

(22) Date of filing of Application :10/05/2021

(43) Publication Date : 11/06/2021

(54) Title of the invention : BROADBAND SINE-SQUARE PROFILED SLOT COUPLED ORTHO MODE TRANSDUCER

(51) International classification	:H01P0001161000, H01P0001060000, G02B0006122000, H01P0011000000, H01P0001163000	(71) Name of Applicant : 1)Indian Space Research Organisation Address of Applicant :Department of Space, Antariksh Bhavan, New BEL Road, Bangalore 560094 Karnataka India
(31) Priority Document No	:NA	(72) Name of Inventor :
(32) Priority Date	:NA	1)Jigar Pandya
(33) Name of priority country	:NA	2)Sagi Sravan Kumar
(86) International Application No	:NA	3)Milind Mahajan
Filing Date	:NA	4)Khagindra Kumar Sood
(87) International Publication No	: NA	5)Rajeev Jyoti
(61) Patent of Addition to Application Number:	NA	6)Rajesh Patel
Filing Date	:NA	
(62) Divisional to Application Number	:NA	
Filing Date	:NA	

(57) Abstract :

Abstract An Ortho Mode Transducer uses a sine-square profile in coupling region and coupling slot in waveguide configuration to achieve broadband performance and comprises of a circular waveguide comprises of two circular waveguide ports at the ends (1,3) and a taper region (2), four branching waveguides (5) and four sine-square profiled coupling apertures (4). The taper region (2) of the waveguide has sine-square profiled section (2a) and comprises of a sine-square profiled slot coupling junction (2b) along the periphery of the waveguide such that a portion of the sine-square profiled coupling aperture (4) is aligned parallel to the axis of the waveguide, while the remaining part of the sine-square profiled coupling aperture (4) runs along the sine-square profiled section (2a) of the taper region (2).

No. of Pages : 22 No. of Claims : 9

(12) PATENT APPLICATION PUBLICATION

(21) Application No.202141021030 A

(19) INDIA

(22) Date of filing of Application :10/05/2021

(43) Publication Date : 11/06/2021

(54) Title of the invention : PRIVACY PRESERVING SPATIAL RANGE QUERY OVER OUTSOURCED ENCRYPTED DATA

<p>(51) International classification :G06F0016290000, H04W0004020000, G06F0021620000, G06F0016953700, H04L0009300000</p> <p>(31) Priority Document No :NA</p> <p>(32) Priority Date :NA</p> <p>(33) Name of priority country :NA</p> <p>(86) International Application No :NA</p> <p>Filing Date :NA</p> <p>(87) International Publication No : NA</p> <p>(61) Patent of Addition to Application Number :NA</p> <p>Filing Date :NA</p> <p>(62) Divisional to Application Number :NA</p> <p>Filing Date :NA</p>	<p>(71)Name of Applicant :</p> <p>1)A.Chandra Mouli, Associate Professor/ Department of CSE, Potti Sriramulu Chalavadi Mallikarjuna Rao College of Engineering and Technology Address of Applicant :Potti Sriramulu Chalavadi Mallikarjuna Rao College of Engineering and Technology. Kotahapeta,Vijayawada, A.P-520001 Andhra Pradesh India</p> <p>2)Girish Kulkarni, Assistant professor/ Department of CSE, B V Raju Institute of Technology</p> <p>3)Mohammad Manzoor Hussain, Assistant professor/Department of CSE, B V Raju Institute of Technology</p> <p>4)Sahadev Maruti Shinde, Assistant professor/Department of CSE, SVERTTMs College of Engineering Pandharpur</p> <p>5)Sarap Manasa, Student /Department of CSE, Rishi MS Institute of Engineering & Technology for WomenTMs</p> <p>6)Asma Begum, Assistant professor/ Department of CSE, Stanley College of Engineering and Technology for Women</p> <p>(72)Name of Inventor :</p> <p>1)A.Chandra Mouli, Associate Professor/ Department of CSE, Potti Sriramulu Chalavadi Mallikarjuna Rao College of Engineering and Technology</p> <p>2)Girish Kulkarni, Assistant professor/ Department of CSE, B V Raju Institute of Technology</p> <p>3)Mohammad Manzoor Hussain, Assistant professor/Department of CSE, B V Raju Institute of Technology</p> <p>4)Sahadev Maruti Shinde, Assistant professor/Department of CSE, SVERTTMs College of Engineering Pandharpur</p> <p>5)Sarap Manasa, Student /Department of CSE, Rishi MS Institute of Engineering & Technology for WomenTMs</p> <p>6)Asma Begum, Assistant professor/ Department of CSE, Stanley College of Engineering and Technology for Women</p>
--	---

(57) Abstract :

Abstract The Location based services (LBS) have received considerable attention and become more popular and vital recently. However, the use of LBS also poses a potential threat to userTMs location privacy. In this aiming at spatial range query, a popular LBS providing information about POIs (Points of Interest) within a given distance, we present an efficient and privacy-preserving location based query solution, called EPLQ. Specifically, to achieve privacy preserving spatial range query, we propose the first predicate only encryption scheme for inner product range, which can be used to detect whether a position is within a given circular area in a privacy-preserving way. Significant challenges still remain in the design of privacy preserving LBS, and new challenges arise particularly due to data outsourcing. In recent years, there is a growing trend of outsourcing data including LBS data because of its financial and operational benefits. Lying at the intersection of mobile computing and cloud computing, designing privacy-preserving outsourced spatial range query faces the challenges. The techniques used to realize privacy preserving query usually increase the search latency. A novel predicate-only encryption scheme for inner product range named IPRE, which allows testing whether the inner product of two vectors is within a given range without disclosing the vectors and an efficient solution for privacy-preserving spatial range query. In particular, we show that whether POI matches a spatial range query or not can be tested by examining whether the inner product of two vectors is in a given range. This can be used for more kinds of privacy-preserving queries over outsourced data. In the spatial range query discussed in this work, we consider Euclidean distance, which is widely used in spatial databases. EPLQ, we have designed a novel predicate-only encryption scheme for inner product range named IPRE and a novel privacy-preserving index tree named ss-tree.

No. of Pages : 13 No. of Claims : 4

(12) PATENT APPLICATION PUBLICATION

(21) Application No.202141021100 A

(19) INDIA

(22) Date of filing of Application :10/05/2021

(43) Publication Date : 11/06/2021

(54) Title of the invention : DESIGN AND FABRICATION OF MICROSTRIP PATCH ANTENNA FOR WIRELESS 5G APPLICATIONS

<p>(51) International classification :H01Q0009040000, H01Q0001380000, H01Q0009060000, H01Q0001500000, H01Q0001220000</p> <p>(31) Priority Document No :NA (32) Priority Date :NA (33) Name of priority country :NA (86) International Application No :NA Filing Date :NA (87) International Publication No : NA (61) Patent of Addition to Application Number :NA Filing Date :NA (62) Divisional to Application Number :NA Filing Date :NA</p>	<p>(71)Name of Applicant :</p> <p>1)Dr Anandhi Meena B,Anna University Address of Applicant :Teaching Fellow, ECE Anna University, University College of Engineering - Dindigul Tamil Nadu India 624622 Tamil Nadu India</p> <p>2)S Parameswari,Kalasalingam Institute of Technology 3)Dr Prasanna Kumar Singh,Noida Institute of Engineering and Technology 4)Dr Arvind Kumar Shukla,IFTM University 5)Santosh Kumar S,Sri Venkateshwara College of Engineering 6)Dr. Shivashankar,Sri Venkateshwara College of Engineering 7)Dr.S.Sugumaran,Vishnu Institute of Technology 8)Dr.M.Kavitha,K Ramakrishnan college of technology 9)Dr Sandip D Satav,JSPM's Jayawantrao Sawant COE 10)Dr. Milind Bhalchandra Tadwalkar,Jayawantrao Sawant College of Engineering 11)Sandeep Kumar Jain,Vivekananda Global University 12)Bhojraj Agrawal,Vivekananda Global University</p> <p>(72)Name of Inventor :</p> <p>1)Dr Anandhi Meena B,Anna University 2)S Parameswari,Kalasalingam Institute of Technology 3)Dr Prasanna Kumar Singh,Noida Institute of Engineering and Technology 4)Dr Arvind Kumar Shukla,IFTM University 5)Santosh Kumar S,Sri Venkateshwara College of Engineering 6)Dr. Shivashankar,Sri Venkateshwara College of Engineering 7)Dr.S.Sugumaran,Vishnu Institute of Technology 8)Dr.M.Kavitha,K Ramakrishnan college of technology 9)Dr Sandip D Satav,JSPM's Jayawantrao Sawant COE 10)Dr. Milind Bhalchandra Tadwalkar,Jayawantrao Sawant College of Engineering 11)Sandeep Kumar Jain,Vivekananda Global University 12)Bhojraj Agrawal,Vivekananda Global University</p>
---	---

(57) Abstract :

Advanced high speed wireless communication has attracted the researchers to focus on designing antennas which can provide optimal radiation. In the current era, 5G wireless communication has occupied the network world as its features are better compared to 4G wireless communication. In this invention we focus on designing circular microstrip patch antenna operating at a resonant frequency of 28.5 GHz with microstrip feed line such that it can be utilized for high speed 5G applications using simulation software CST Microwave Studio. We have selected RT/Duroid 5880 as the substrate material where the substrate height is of 0.65mm with a dielectric constant value of $\epsilon_r = 2.2$ and a loss tangent of 1×10^{-3} . This design is fabricated and analyzed which is found to be very efficient in providing optimal radiation of almost 100%. This antenna design is reliable for advanced high speed networks such as 5G applications with high gain of 10 dB, good return loss of -32.86 dB and an increased bandwidth of 1.636 GHz.

No. of Pages : 12 No. of Claims : 6

(12) PATENT APPLICATION PUBLICATION

(21) Application No.202141021161 A

(19) INDIA

(22) Date of filing of Application :10/05/2021

(43) Publication Date : 11/06/2021

(54) Title of the invention : A COOLANT PIPE FOR CONCRETE ROOF

(51) International classification	:F28D0015040000, F25B0039040000, F25B0043000000, F28D0015020000, F28B0001020000	(71) Name of Applicant : 1)KARUNYA INSTITUTE OF TECHNOLOGY AND SCIENCES Address of Applicant :KARUNYA INSTITUTE OF TECHNOLOGY AND SCIENCES, KARUNYA NAGAR, COIMBATORE-641 114 Tamil Nadu India
(31) Priority Document No	:NA	(72) Name of Inventor :
(32) Priority Date	:NA	1)Dr.TRIJO THARAYIL
(33) Name of priority country	:NA	2)Dr.LAZARUS GODSON ASIRVATHAM
(86) International Application No	:NA	
Filing Date	:NA	
(87) International Publication No	: NA	
(61) Patent of Addition to Application Number:	NA	
Filing Date	:NA	
(62) Divisional to Application Number	:NA	
Filing Date	:NA	

(57) Abstract :

A COOLANT PIPE FOR CONCRETE ROOF A coolant pipe for concrete roof cooling relates to an elongated coolant member(1) with nanomaterial coating (2) to enhance the heat transfer capabilities and porous, permeable layer (3) to acting as a capillary wick and a working fluid(4) at a low pressure. The heat absorbed from the concrete roof is converted into vapour, which is then condensed to liquid. The liquid is returned through the capillary wick to repeat the cycle. An arrangement of coolant pipes with condenser(5) integrated in the concrete surface is capable of cooling the concrete roof and also generates hot water without electricity.

No. of Pages : 23 No. of Claims : 15

(12) PATENT APPLICATION PUBLICATION

(21) Application No.202141021169 A

(19) INDIA

(22) Date of filing of Application :10/05/2021

(43) Publication Date : 11/06/2021

(54) Title of the invention : MULTI-ROTOR HORIZONTAL WIND TURBINE

<p>(51) International classification :F03D0009250000, F03D0001060000, F03D0001020000, F03D0013200000, B64C0027080000</p> <p>(31) Priority Document No :NA (32) Priority Date :NA (33) Name of priority country :NA (86) International Application No :NA Filing Date :NA (87) International Publication No : NA (61) Patent of Addition to Application Number:NA Filing Date :NA (62) Divisional to Application Number :NA Filing Date :NA</p>	<p>(71)Name of Applicant : 1)Dr.D.MURUGANANDAM Address of Applicant :Plot No.28, Jagajeeva Ram Nagar, Selai Yur (Post),Chennai-600073 TamilNadu,India Tamil Nadu India 2)Dr.J.JAYAPRIYA 3)SANKARLAL R L 4)SARALADEVY R 5)RAJINI RAM G 6)Dr.K.SUBATHRA 7)J KOMATHI 8)J.THIRUNAVUKKARASU 9)J.MALATHI 10)K.VELAVAN 11)J. JAYACHANDRAN 12)PARTHIBAN MANI 13)M.ISWARYA 14)V.ESRA 15)V.SUMATHI</p> <p>(72)Name of Inventor : 1)Dr.D.MURUGANANDAM 2)Dr.J.JAYAPRIYA 3)SANKARLAL R L 4)SARALADEVY R 5)RAJINI RAM G 6)Dr.K.SUBATHRA 7)J KOMATHI 8)J.THIRUNAVUKKARASU 9)J.MALATHI 10)K.VELAVAN 11)J. JAYACHANDRAN 12)PARTHIBAN MANI 13)M.ISWARYA 14)V.ESRA 15)V.SUMATHI</p>
--	--

(57) Abstract :

MULTI-ROTOR HORIZONTAL WIND TURBINE Accordingly, embodiments herein disclose a multi-rotor horizontal wind turbine (100) comprising a tower (9) which holds the wind turbine (100) and supports a nacelle (7), a rotor hub (2), a plurality of blades (1), and the other wind turbine equipments. The plurality of blades (1) is designed and arranged perpendicular to translate the relative motion of the wind. When the airflows pass over the blades (1), the wind speed and pressure differential is created between the upper and lower surfaces of the blades (1) and due to the higher pressure at the lower surface, the lift force acts to the blades (1) which in turn translate the rotational motion to the blades (1). These lift propelled turbines have higher efficiency and maximum performance is achieved with the five-bladed design arrangements. Figures to be published with Abstract: Fig. 1

No. of Pages : 16 No. of Claims : 10

(12) PATENT APPLICATION PUBLICATION

(21) Application No.202141021173 A

(19) INDIA

(22) Date of filing of Application :11/05/2021

(43) Publication Date : 11/06/2021

(54) Title of the invention : BRICK-WALLED SOLAR DISTILLATION SYSTEM

(51) International classification	:C02F0001140000, B01D0005000000, C02F0001040000, B01D0001000000, F24F0013220000	(71)Name of Applicant : 1)Dr.S.Joe Patrick Gnanaraj Address of Applicant :Associate Professor Department of Mechanical Engineering Francis Xavier Engineering College Tirunelveli Tamil Nadu India 2)Dr.Zeenathul Farida Abdul Gani, Francis Xavier engineering college 3)Dr.S.Amal Bosco Jude, University VOC College of Engineering 4)S.Rajakumar, University VOC College of Engineering 5)N.Sankareswaran, Anna University Regional Campus 6)Dr. V.Kannan, Thoothukudi
(31) Priority Document No	:NA	(72)Name of Inventor : 1)Dr S Ramachandran, CMR Institute of Technology 2)Dr.V.Kannan, Thoothukudi 3)S. Rajakumar, University VOC College of Engineering 4)Dr.S.Amal Bosco Jude, University VOC College of Engineering 5)N.Sankareswaran, Anna University Regional Campus 6)Dr.S.Joe Patrick Gnanaraj, FXEC
(32) Priority Date	:NA	
(33) Name of priority country	:NA	
(86) International Application No	:NA	
Filing Date	:NA	
(87) International Publication No	: NA	
(61) Patent of Addition to Application Number	:NA	
Filing Date	:NA	
(62) Divisional to Application Number	:NA	
Filing Date	:NA	

(57) Abstract :

The present invention is a solar distillation system fabricated by means of bricks. The entire still is divided into compartments (2) as per the user need. Each compartment(2) has a provision for storing the distilled water(3) collected by condensation process. The collected water(3) in the compartments is a pure condensed water which are ready for drinking. There is a provision on each side to collect the distilled water (3) without usage. The brick-walled solar still rests on a stand(4). The hollow bricks used for the construction provides an environment for collecting the distillate. This provides a perfect alternate to produce purified water in places of water scarcity.

No. of Pages : 15 No. of Claims : 5

(12) PATENT APPLICATION PUBLICATION

(21) Application No.202141021184 A

(19) INDIA

(22) Date of filing of Application :11/05/2021

(43) Publication Date : 11/06/2021

(54) Title of the invention : SMART GARBAGE MONITORING SYSTEM USING SENSORS WITH RFID OVER INTERNET OF THINGS

(51) International classification	:B65F0001140000, B65F0001000000, G06K0017000000, B65F0001160000, G08B0021220000	(71) Name of Applicant : 1)Dr.M.NARAYANAN Address of Applicant :Dr.M.NARAYANAN S/O MADESHAN, No: 1/237, Kumbarahalli, P.Pallipatti Post, Pappireddipatty Taluk, Dharmapuri District, Tamil Nadu, Pin: 635 301 Tamil Nadu India
(31) Priority Document No	:NA	2)Dr. P.Santosh Kumar Patra
(32) Priority Date	:NA	3)Dr.T.POONGOTHAI
(33) Name of priority country	:NA	4)Dr. N. SATHEESH
(86) International Application No	:NA	5)Dr. R SANTHOSHKUMAR
Filing Date	:NA	6)Dr. B.RAJALINGAM
(87) International Publication No	: NA	(72) Name of Inventor :
(61) Patent of Addition to Application Number	:NA	1)Dr.M.NARAYANAN
Filing Date	:NA	
(62) Divisional to Application Number	:NA	
Filing Date	:NA	

(57) Abstract :

7. ABSTRACT A smart garbage monitoring system (100) using Sensors with RFID over internet of things is disclosed. The proposed technology is related to a new garbage collecting way to dispose the waste by using the latest technology. In this technology few sensors are incorporated to the smart bin (11) like photoelectric sensor (16) that detect the clear representation objects, weight sensor (20) that calculate the percentage of the garbage dumped inside the bin (11) and the IR sensor (14). When a person drops the garbage into the bin (11) the Radio frequency identification (RFID) CARD reader (18) reads all the information about that particular person (12) and send a message to him that the materials dropped inside the bin (11) and an appreciation message for using the bin (11). The IR sensor (14) sends the updated information to the concerned authorities (10) who are responsible for that particular area. So, the concerned authorities (12) continuously receive the messages until the bin (11) is squashed and each bin (11) is assigned with a unique ID. With the help of these sensors™ authorities (10) identifies the information about the bin (11) up to date by the unique ID of the bin (11). If the bin (11) is overflowing, the concerned authorities (10) can easily identify the bin (100) location and squash it as early as possible. So, people can again use it. Figure related to abstract is Fig.1.

No. of Pages : 18 No. of Claims : 9

(12) PATENT APPLICATION PUBLICATION

(21) Application No.202141021200 A

(19) INDIA

(22) Date of filing of Application :11/05/2021

(43) Publication Date : 11/06/2021

(54) Title of the invention : SYSTEM FOR MANAGEMENT OF VENTILATORS FOR COVID PATIENTS IN HOSPITAL USING BLOCK CHAIN

(51) International classification	:G16H0040200000, H04W0084180000, B01F0011000000, G06Q0050300000, C07H0001060000	(71)Name of Applicant : 1)Dr. Ananth Prabhu G Address of Applicant :Professor, Department of Computer Science and Engineering, Sahyadri College of Engineering and Management, Mangalore, Karnataka, India Karnataka India 2)Dr.Karuna Pandit 3)Dr. Mustafa Basthikodi 4)Dr. Nethravathi P.S 5)Dr Manjula Sanjay Koti 6)Dr. Anush Bekal 7)Shilpashree S 8)Rohan Don Salins 9)Sonia V. Soans 10)Vaishak N L
(31) Priority Document No	:NA	(72)Name of Inventor :
(32) Priority Date	:NA	1)Dr. Ananth Prabhu G
(33) Name of priority country	:NA	2)Dr.Karuna Pandit
(86) International Application No	:NA	3)Dr. Mustafa Basthikodi
Filing Date	:NA	4)Dr. Nethravathi P.S
(87) International Publication No	: NA	5)Dr Manjula Sanjay Koti
(61) Patent of Addition to Application Number	:NA	6)Dr. Anush Bekal
Filing Date	:NA	7)Shilpashree S
(62) Divisional to Application Number	:NA	8)Rohan Don Salins
Filing Date	:NA	9)Sonia V. Soans
		10)Vaishak N L

(57) Abstract :

The present invention relates to system for management of ventilators for covid patients in hospital using block chain. The objective of the present invention is to solve the problems in the prior art technologies of hospital resource management.

No. of Pages : 25 No. of Claims : 4

(12) PATENT APPLICATION PUBLICATION

(21) Application No.202141021252 A

(19) INDIA

(22) Date of filing of Application :11/05/2021

(43) Publication Date : 11/06/2021

(54) Title of the invention : MACHINE LEARNING BASED DATA MINING FOR ANALYSIS OF STUDENTS PROFILE IN UNIVERSITIES

(51) International classification	:G06Q0050200000, G06K0009620000, G06Q0010060000, H04W0024040000, G01R0027280000	(71)Name of Applicant : 1)Dr. T G Basavaraju, Government SKSJ Technological Institute Address of Applicant :Professor, Government SKSJ Technological Institute - Bangalore Karnataka India 2)Vasanthakumara M, Government SKSJ Technological Institute 3)Dr. Surekha K B, BMS Institute of Technology 4)Dr. Nirmala Hiremani, Visvesvaraya Technological University 5)Dr. Adarsha Sagar H V , Presidency University
(31) Priority Document No	:NA	(72)Name of Inventor :
(32) Priority Date	:NA	1)Dr. T G Basavaraju, Government SKSJ Technological Institute
(33) Name of priority country	:NA	2)Vasanthakumara M, Government SKSJ Technological Institute
(86) International Application No	:NA	3)Dr. Surekha K B, BMS Institute of Technology
Filing Date	:NA	4)Dr. Nirmala Hiremani, Visvesvaraya Technological University
(87) International Publication No	: NA	5)Dr. Adarsha Sagar H V , Presidency University
(61) Patent of Addition to Application Number	:NA	
Filing Date	:NA	
(62) Divisional to Application Number	:NA	
Filing Date	:NA	

(57) Abstract :

Students are the strength of any educational institution whose quality is measured by the process of official recognition termed as Accreditation. The measurement of quality focuses on strength of students hence educational institutions give more importance to prevent drop out of students as high dropping rate of students create bad impact on the institutions resulting in low grade accreditation and finally ends in bad reputation. This invention involves data mining technique for analyzing the student educational data which is utilized by the classification method for predicting the student drop out in undergraduate level at XYZ University. Prediction of student drop out is done based on the raw student academics data enrolled in the university for a particular academic year. Imbalanced raw data is handled through preprocessing where in our invention imbalance dataset is handled by synthetic minority oversampling technique. Followed by which student drop out is predicted using random forest algorithm thereby providing accurate results of 93.5 %. These results can be utilized for reducing the drop out level of students by identification of related potential factors.

No. of Pages : 11 No. of Claims : 6

(12) PATENT APPLICATION PUBLICATION

(21) Application No.202141021273 A

(19) INDIA

(22) Date of filing of Application :11/05/2021

(43) Publication Date : 11/06/2021

(54) Title of the invention : SMART ENTRY POINTS AT PUBLIC PLACES

(51) International classification	:G08B0013240000, G01J0005000000, G10L0025510000, G06N0020000000, G07F0019000000	(71)Name of Applicant : 1)Dr. Supriya V G Address of Applicant :Department of ECE, SIR M Visvesvaraya Institute of Technology affiliated to Visvesvaraya Technological University Belagavi , Hunasamarahalli, Yelahanka, off International airport road, Bangalore-562157 Email Id : drsupriya_ec@sirmvit.edu Phone : 9480690830 Karnataka India
(31) Priority Document No	:NA	2)Dr. Rachappa Jopate
(32) Priority Date	:NA	3)Dr. DivyaJyothi M.G.
(33) Name of priority country	:NA	4)Supritha N
(86) International Application No	:NA	5)Mr. Anoop N prasad
Filing Date	:NA	6)Dr.Chethana Sridhar
(87) International Publication No	: NA	(72)Name of Inventor :
(61) Patent of Addition to Application Number	:NA	1)Dr. Supriya V G
Filing Date	:NA	2)Dr. Rachappa Jopate
(62) Divisional to Application Number	:NA	3)Dr. DivyaJyothi M.G.
Filing Date	:NA	4)Supritha N
		5)Mr. Anoop N prasad
		6)Dr.Chethana Sridhar

(57) Abstract :

The invention discloses a novel mechanism wherein entry is authorised to people who are wearing masks properly, who have sanitised their hands, have temperature within acceptable limits and are not having uneasiness. The aforesaid conditions are monitored using various sensors and using machine learning the surveillance is done without any need of personnel. In case any discrepancy is observed alerting system will inform the personnel to restrict the entry of the airborne disease carrier.

No. of Pages : 9 No. of Claims : 1

(54) Title of the invention : A SMART APPLICATION FOR DELIVERING MEDICINE AT HOME USING E-PRESCRIPTION

<p>(51) International classification</p> <p>(31) Priority Document No</p> <p>(32) Priority Date</p> <p>(33) Name of priority country</p> <p>(86) International Application No Filing Date</p> <p>(87) International Publication No</p> <p>(61) Patent of Addition to Application Number Filing Date</p> <p>(62) Divisional to Application Number Filing Date</p>	<p>:G06Q0050220000, G16H0010600000, G16H0050200000, G16H0040670000, G16H0010650000</p> <p>:NA</p> <p>:NA</p> <p>:NA</p> <p>:NA</p> <p>:NA</p> <p>: NA</p> <p>:NA</p> <p>:NA</p> <p>:NA</p> <p>:NA</p>	<p>(71)Name of Applicant :</p> <p>1)Mrs. M. Prameela Address of Applicant :Assistant Professor, Freshman Engineering Department, Prasad V. Potluri Siddhartha Institute of Technology, Vijayawada-520007. Andhra Pradesh India</p> <p>2)Shaik Mohammed Rafi</p> <p>3)Mr. Shivcharan singh Gandhar</p> <p>4)Mr. Shafqat Nabi Mughal</p> <p>5)Rukhsana Thaker</p> <p>6)Dr. Shanmugananth.</p> <p>7)ANWESH PRADHAN</p> <p>8)Kakirala Durga Bhavani</p> <p>9)Dr.J.Muthukumaran</p> <p>10)Dr. Harikumar Pallathadka</p> <p>11)Mr. Sankararao Majji</p> <p>12)Kaviyaraj R</p> <p>(72)Name of Inventor :</p> <p>1)Mrs. M. Prameela</p> <p>2)Shaik Mohammed Rafi</p> <p>3)Mr. Shivcharan singh Gandhar</p> <p>4)Mr. Shafqat Nabi Mughal</p> <p>5)Rukhsana Thaker</p> <p>6)Dr. Shanmugananth.</p> <p>7)ANWESH PRADHAN</p> <p>8)Kakirala Durga Bhavani</p> <p>9)Dr.J.Muthukumaran</p> <p>10)Dr. Harikumar Pallathadka</p> <p>11)Mr. Sankararao Majji</p> <p>12)Kaviyaraj R</p>
--	---	--

(57) Abstract :

The purpose of this research was to create an E-prescribing application for patients based on the Smartphone. The application is expected to provide an overview of medication that the patient is given during hospitalization and allow the patient to interact with the doctor to receive prescriptions for the profuse syndrome. Online medical system is online web portal where doctors, hospital do the task of providing online treatment to patients avoid crowding. The treatment can be done by selecting symptoms or pair of symptoms age wise. After payment done, then by selecting appropriate nearby medical store patients get home delivery of medicine. The service of this portal can be accessible on mobile by installing application. The service can be accessible on both PCs, laptop and mobile.

No. of Pages : 6 No. of Claims : 5

(12) PATENT APPLICATION PUBLICATION

(21) Application No.202141021280 A

(19) INDIA

(22) Date of filing of Application :11/05/2021

(43) Publication Date : 11/06/2021

(54) Title of the invention : A NOVEL FUZZY DECISION FOR BETTER HETEROGENEOUS MANET

<p>(51) International classification</p> <p>(31) Priority Document No</p> <p>(32) Priority Date</p> <p>(33) Name of priority country</p> <p>(86) International Application No Filing Date</p> <p>(87) International Publication No</p> <p>(61) Patent of Addition to Application Number Filing Date</p> <p>(62) Divisional to Application Number Filing Date</p>	<p>:G08C0017020000, H04L0012240000, H04B0007060000, H04W0012040000, H04B0010112000</p> <p>:NA</p> <p>:NA</p> <p>:NA</p> <p>:NA</p> <p>:NA</p> <p>: NA</p> <p>:NA</p> <p>:NA</p> <p>:NA</p> <p>:NA</p> <p>:NA</p>	<p>(71)Name of Applicant :</p> <p>1)Dr. B. S. Kiruthika Devi, Assistant Professor Address of Applicant :Department of Information Technology, Sri Sairam Engineering College, Chennai Tamil Nadu India</p> <p>2)R Logeshwari, Assistant Professor</p> <p>3)T.Malathi, Assistant Professor</p> <p>4)Dr Sivaramakrishnan S, Assistant professor</p> <p>5)Dr G Suseela, Assistant professor</p> <p>6)Prathima Devadass, Research Scholar</p> <p>7)V. Kiruthiga, Research Scholar</p> <p>8)Venkatesan Pillai, Professor</p> <p>9)Praveena Rachel Kamala S, Assistant Professor</p> <p>10)Dr. B. Prabhu kavin, Assistant Professor</p> <p>(72)Name of Inventor :</p> <p>1)Dr. B. S. Kiruthika Devi, Assistant Professor</p> <p>2)R Logeshwari, Assistant Professor</p> <p>3)T.Malathi, Assistant Professor</p> <p>4)Dr Sivaramakrishnan S, Assistant professor</p> <p>5)Dr G Suseela, Assistant professor</p> <p>6)Prathima Devadass, Research Scholar</p> <p>7)V. Kiruthiga, Research Scholar</p> <p>8)Venkatesan Pillai, Professor</p> <p>9)Praveena Rachel Kamala S, Assistant Professor</p> <p>10)Dr. B. Prabhu kavin, Assistant Professor</p>
--	--	---

(57) Abstract :

ABSTRACT Providing secure and low-cost wireless connectivity is a difficult challenge for long-term economic growth. Established wireless channel capacity is being strained by the demand for wireless data services. By adding spatial diversity, this demand can be met. Multiple antenna is one of the most promising methods for dealing with channel fading, and it necessitates the use of multiple antennas at both the transmitter and receiver ends. The fuzzy-based method has been found to be useful for network communication for surveillance with a large number of nodes in communication range. This network is fairly resistant to node configuration changes. Since mesh topology is used to build the network, all of the nodes in the proposed network have some kind of relationship with one another, resulting in network reliability. Because of the relationship between nodes, this device works reliably even in environments where the radio connection quality is low. The proposed method outperforms previous methods in terms of throughput and low end-to-end latency, according to the results of the research.

No. of Pages : 11 No. of Claims : 6

(12) PATENT APPLICATION PUBLICATION

(21) Application No.202141021300 A

(19) INDIA

(22) Date of filing of Application :11/05/2021

(43) Publication Date : 11/06/2021

(54) Title of the invention : SMART MULTIMODE ELECTRIC CYCLE

(51) International classification	:H02J0003380000, H01M0010052500, H02J0007350000, B60L0008000000, H02S0020000000	(71) Name of Applicant : 1)Dr. D. KARUNKUZHALI Address of Applicant :Professor, Department of Information Technology, Panimalar Engineering College, Poonamallee, Chennai 600 123, Tamil Nadu, India Tamil Nadu India 2)Dr. S. BRINDHA 3)Dr. R. VENKATESH 4)Dr. T. PONNARASI 5)Dr. R. BHARGAVA RAMA GOWD 6)K. E. LAKSHMI PRABHA 7)Dr. R. AHILA 8)Dr. A. KAVITHA 9)V. SUBASHINI 10)Dr. A. DANIEL
(31) Priority Document No	:NA	(72) Name of Inventor :
(32) Priority Date	:NA	1)Dr. D. KARUNKUZHALI
(33) Name of priority country	:NA	2)Dr. S. BRINDHA
(86) International Application No	:NA	3)Dr. R. VENKATESH
Filing Date	:NA	4)Dr. T. PONNARASI
(87) International Publication No	: NA	5)Dr. R. BHARGAVA RAMA GOWD
(61) Patent of Addition to Application	:NA	6)K. E. LAKSHMI PRABHA
Number	:NA	7)Dr. R. AHILA
Filing Date	:NA	8)Dr. A. KAVITHA
(62) Divisional to Application Number	:NA	9)V. SUBASHINI
Filing Date	:NA	10)Dr. A. DANIEL

(57) Abstract :

ABSTRACT Smart Multimode Electric Cycle This invention is related to a Solar electric cycle to operate by renewable power as the fuel. As renewable power is at no cost, the running cost is zero. In addition, the vehicle does not have emission value. It essentially functions on three modes: Solar mode, Wall plug-in charge and manual pedal mechanism. In solar mode the electricity is stored in lithium ion battery with the help of photovoltaic polycrystalline solar panels. The rider can also opt for normal pedal system in absence of electricity. The operation of solar electric cycle is smooth and silent

No. of Pages : 11 No. of Claims : 3

(12) PATENT APPLICATION PUBLICATION

(21) Application No.202141021319 A

(19) INDIA

(22) Date of filing of Application :11/05/2021

(43) Publication Date : 11/06/2021

(54) Title of the invention : COST EFFECTIVE CONVERGENCE MECHANISM FOR SELF-REGULATING MOLDING MACHINE USING IOT.

(51) International classification	:H04W0004700000, H04L0029080000, A61B0005010000, B29C0045760000, G05B0019180000	(71) Name of Applicant : 1)Dr.I.Daniel Lawrence Address of Applicant :Assistant professor, Department of Mechanical Engineering, Loyola Institute of Technology, Chennai - 600123. Tamil Nadu India
(31) Priority Document No	:NA	(72) Name of Inventor :
(32) Priority Date	:NA	1)Dr.I.Daniel Lawrence
(33) Name of priority country	:NA	2)Dr.M.Thirunavukkarasu
(86) International Application No	:NA	3)Dr. B. Kishore
Filing Date	:NA	4)Mr. C. Sathish
(87) International Publication No	: NA	5)Dr.M.selvakumar
(61) Patent of Addition to Application Number	:NA	6)Mr. T.Ramkumar
Filing Date	:NA	
(62) Divisional to Application Number	:NA	
Filing Date	:NA	

(57) Abstract :

Advancement in Internet of Things (IoT) based real time conveyance has become the modernization technology among the researcher due to reliable and progressive standards. Commercial convergence mechanism is a key to develop self-regulating molding machine, involving a vast range of information and communication technologies incorporating machinery, microcontroller, actuators and sensors at different levels. Furthermore, smart device contributes significance for processing, interacting and communicating towards machine-to-machine using wireless network and Radio Frequency Identification (RFID) technologies. A novel IoT based interface mechanism for self-regulating molding machine attempts to facilitate software based Graphical User Interface (GUI) integrated with distinct sensors, actuators, microcontroller, memory and electronics motors. Subsequently, the sensed information is associated to the cloud platform to analyze the operation functionalities and periodically store data of molding machine in real time aspects.

No. of Pages : 10 No. of Claims : 4

(12) PATENT APPLICATION PUBLICATION

(21) Application No.202141021356 A

(19) INDIA

(22) Date of filing of Application :11/05/2021

(43) Publication Date : 11/06/2021

(54) Title of the invention : A SMART MOBILE APP FOR FRUIT COUNTING AND YIELD ESTIMATION IN FARM USING IMAGE PROCESSING TECHNIQUE

(51) International classification	:G06K0009620000, G06K0009000000, G06N0003040000, G06T0007110000, G06T0007120000	(71) Name of Applicant : 1)Dr. J.M. GNANASEKAR Address of Applicant :Professor, Department of Computer Science and Engineering, Sri Venkateswara College of Engineering, Post Box No: 3, Pennalur, Sriperumbudur - 602 117, Kancheepuram Dist, TamilNadu. Ph: 9444508360 E-Mail: jmg_sekar@yahoo.com Tamil Nadu India
(31) Priority Document No	:NA	2)Mr. S. PRABU
(32) Priority Date	:NA	3)Mrs. K. PARKAVI
(33) Name of priority country	:NA	4)Mr. S. PALPANDI
(86) International Application No	:NA	5)Mr. GOWTHAM CHINNARAJU
Filing Date	:NA	(72) Name of Inventor :
(87) International Publication No	: NA	1)Dr. J.M. GNANASEKAR
(61) Patent of Addition to Application Number	:NA	2)Mr. S. PRABU
Filing Date	:NA	3)Mrs. K. PARKAVI
(62) Divisional to Application Number	:NA	4)Mr. S. PALPANDI
Filing Date	:NA	5)Mr. GOWTHAM CHINNARAJU

(57) Abstract :

ABSTRACT OF THE INVENTION A Smart Mobile Application based yield estimation and fruit counting consists of three separate stages internally and they are Image Segmentation for segmenting the object of interest fruits alone, Classification using Support Vector Machine (SVM) classifier for identifying the fruit from entire background image and finally it comes to total yield estimation and automatic fruit counting cumulatively. The captured raw image from the fruit farm is initially processed and converted into its equivalent binary representation after the removal of noise or unwanted pixel values from the image. Now, Image Segmentation is done based on region of interest and performs the feature extraction which in turn generates a pattern of objects. Then, image classification is performed with the help of Support Vector Machine - SVM classifier which involves Normalization, Selecting Activation function, Optimizing parameters after cross validation, Training the model, Testing the model and Evaluate the model performance. After this, training and testing phase leads to train the network model and test them to validate against the final outcome versus backend training dataset images which are used to train the network model. It is then proceeded to predict the object i.e. fruits from the captured image taken in farm and thus estimates the total predicted yield and counts the total number of fruits available in the farm cumulatively. In this way, a smart Mobile App for Fruit counting and Yield estimation in farm helps the farmer to use the Agricultural farm resources effectively and in turn improves the overall farm yield.

No. of Pages : 11 No. of Claims : 5

(12) PATENT APPLICATION PUBLICATION

(21) Application No.202141021385 A

(19) INDIA

(22) Date of filing of Application :12/05/2021

(43) Publication Date : 11/06/2021

(54) Title of the invention : METHOD FOR QUERY EXPANSION USING WORD SENSE DISAMBIGUATION ON TELUGU TEXT CORPUS FOR INFORMATION RETRIEVAL PROCESS

(51) International classification	:G06F0016330000, G06F0040300000, G06F0016310000, G06F0016332000, G06F0016953500	(71) Name of Applicant : 1)Dr. Neeraja Koppula Address of Applicant :Faculty, Department of Information Technology, MLR Institute of Technology, Dundigal, Hyderabad- 500043, Telangana, India Telangana India 2)Dr. B. Padmaja Rani 3)Dr. K. Srinivas Rao
(31) Priority Document No	:NA	(72) Name of Inventor :
(32) Priority Date	:NA	1)Dr. Neeraja Koppula
(33) Name of priority country	:NA	2)Dr. B. Padmaja Rani
(86) International Application No	:NA	3)Dr. K. Srinivas Rao
Filing Date	:NA	
(87) International Publication No	: NA	
(61) Patent of Addition to Application Number:	NA	
Filing Date	:NA	
(62) Divisional to Application Number	:NA	
Filing Date	:NA	

(57) Abstract :

METHOD FOR QUERY EXPANSION USING WORD SENSE DISAMBIGUATION ON TELUGU TEXT CORPUS FOR INFORMATION RETRIEVAL PROCESS The availability of digital documents in the Indian languages is increased due to the availability of high speed internet facility. To access the information from digital documents, effective and efficient methods are required. The words in the documents play a vital role in all prior methods, since sentences and documents depends on words. To improve the accuracy of the information retrieval system, query expansion techniques are used in all Indian languages. Polysemy word Sense identification is important for Indian languages to improve the information retrieval results where different query expansion methods are applied. In our invention, query expansion methodology was proposed for disambiguating the polysemy word in Telugu language using WSD methods and semantic network. In information retrieval system, to improve search results, the users query is enriched with the senses of the polysemous word. For the given input query term searching the senses of the polysemous (disambiguated) word will expands the query automatically. In this context, word and sense relationships must be taken into consideration to reformulate root query in regional Telugu language. The semantic network attempts to capture the relationships between words and senses. The obtained sense is replaced in the query reformulation and this reformulated query is used for information retrieval process.

No. of Pages : 11 No. of Claims : 5

(12) PATENT APPLICATION PUBLICATION

(21) Application No.202141021389 A

(19) INDIA

(22) Date of filing of Application :12/05/2021

(43) Publication Date : 11/06/2021

(54) Title of the invention : PERFORMANCE ENHANCEMENT IN MIMO-OFDM SYSTEM USING FUZZY INFERENCE ARTIFICIAL NEURAL NETWORK

(51) International classification	:H04L0027260000, H04L0025030000, H04W0052260000, H04L0027340000, H04L0001040000	(71)Name of Applicant : 1)Dr.P.V.Naganjaneyulu Address of Applicant :Professor of ECE and Principal, Sri Mittapalli College of Engineering, Thummalapalem, Guntur District, Andhra Pradesh, India. Pin Code: 522019 Andhra Pradesh India 2)Dr.P.Nageswara Rao 3)Mrs.N.Renuka 4)Mr.Kiran Mannem 5)Mr.K.Jamal 6)Dr.Koteswara Rao Seelam 7)Mr.V.T Venkateswarlu
(31) Priority Document No	:NA	(72)Name of Inventor : 1)Dr.P.V.Naganjaneyulu 2)Dr.P.Nageswara Rao 3)Mrs.N.Renuka 4)Mr.Kiran Mannem 5)Mr.K.Jamal 6)Dr.Koteswara Rao Seelam 7)Mr.V.T Venkateswarlu
(32) Priority Date	:NA	
(33) Name of priority country	:NA	
(86) International Application No	:NA	
Filing Date	:NA	
(87) International Publication No	: NA	
(61) Patent of Addition to Application Number	:NA	
Filing Date	:NA	
(62) Divisional to Application Number	:NA	
Filing Date	:NA	

(57) Abstract :

The Wireless World today transmitting Data in the form of Text, Images and Videos over a long distance through a Digital Communication System. This Digital Communication System uses single carrier for transmitting the Data over a long distance leads to Lower Data Transmission Rate, Lower Spectral Efficiency and Lower Reliability. The Multi-Input, Multi-Output-Orthogonal Frequency Division Multiplexing (MIMO-OFDM) is the present best suitable wireless interfacing system for 4G or 5G Wireless Communications. This MIMO-OFDM uses multiple carriers, can offers higher Data Transmission Rate, Spectral Efficiency, and Reliability. The PAPR which is the ratio of peak power to the average power of a signal and significant parameter to be considering for effective utilization of MIMO-OFDM in Wireless Communications, the higher value of PAPR degrades the transmitted signal. The present invention disclosed herein is Performance Enhancement in MIMO-OFDM System using Fuzzy Inference Artificial Neural Network comprising of: Data Symbols (201); Modulation (202); Inverse FFT (203); Fuzzy Inference Artificial Neural Network (204); Encoder (205); Fading (206); Noise (207); Decoder (208); Equalization (209); Demodulation (210); and Re-Generated Data Symbols (211); used to reduce higher PAPR in MIMO-OFDM System by the use of Fuzzy Inference Artificial Neural Network. The present invention disclosed here shows the superior performance in reducing the PAPR and the performance parameters estimated are PAPR of 6.8dB, and SNR of 7.82dB.

No. of Pages : 14 No. of Claims : 9

(12) PATENT APPLICATION PUBLICATION

(21) Application No.202141021391 A

(19) INDIA

(22) Date of filing of Application :12/05/2021

(43) Publication Date : 11/06/2021

(54) Title of the invention : IOT UAV SYSTEM FOR EFFICIENT FIRE DETECTION IN UNMANNED FOREST USING WIRELESS SENSOR NETWORKS AND IMAGE PROCESSING

(51) International classification	:A61B0005000000, G08B0013193000, H04N0005232000, G01V0001220000, H04W0088080000	(71)Name of Applicant : 1)Dr.V.Arulkumar (Assistant Professor, Sri Krishna College of Engineering and Technology) Address of Applicant :Assistant Professor, Computer Science and Business Systems (TCS), Sri Krishna College of Engineering and Technology, Coimbatore. Tamil Nadu India 2)Dr. V. S. Manjula, College of Informatics, Wollo University 3)Mr. A. Ranjith, St. Joseph University in Tanzania 4)Mr.S.Arockia Jayadhas, Joseph University in Tanzania 5)Dr. Shashi Raj K, Dayananda Sagar College of Engineering 6)Dr. Prakash Kuravatti, ATME College of Engineering,
(31) Priority Document No	:NA	(72)Name of Inventor : 1)Dr.V.Arulkumar (Assistant Professor, Sri Krishna College of Engineering and Technology) 2)Dr. V. S. Manjula, College of Informatics, Wollo University 3)Mr. A. Ranjith, St. Joseph University in Tanzania 4)Mr.S.Arockia Jayadhas, Joseph University in Tanzania 5)Dr. Shashi Raj K, Dayananda Sagar College of Engineering 6)Dr. Prakash Kuravatti, ATME College of Engineering,
(32) Priority Date	:NA	
(33) Name of priority country	:NA	
(86) International Application No	:NA	
Filing Date	:NA	
(87) International Publication No	: NA	
(61) Patent of Addition to Application Number	:NA	
Filing Date	:NA	
(62) Divisional to Application Number	:NA	
Filing Date	:NA	

(57) Abstract :

Advances in sensors make VSN the most suitable technique for detecting forest fires. The sensor provides more precise data on this region at all times. Its main advantages are a scalable network and coverage of various sizes. The sensor is able to observe the physical parameters that surround it. We can connect to VSN device and add more sensors to collect different parameters. The sensors can be placed anywhere in the most common places and there is no need to build a tower. The system includes sensor nodes, detection zones and base stations. Environmental parameters are periodically monitored using sensors placed in areas of interest. Each detected data is sent from one node to another node and then directed to the base station. The base station analyzes the monitored decision-making information and provides the data to various users for analysis around the world via the Internet.

No. of Pages : 6 No. of Claims : 6

(12) PATENT APPLICATION PUBLICATION

(21) Application No.202141021487 A

(19) INDIA

(22) Date of filing of Application :12/05/2021

(43) Publication Date : 11/06/2021

(54) Title of the invention : A PROCESS OF RECOVERING SERICIN FROM SILK DEGUMMING WASTE SOLUTION USING AN ELECTROCHEMICAL CELL

(51) International classification	:D01C0003020000, A61K0008640000, H01M0010440000, C25C0007000000, C01B0003500000	(71) Name of Applicant : 1)Nanosentrix Private Limited Address of Applicant :Jyothy Institute of Technology Campus Thataguni, Off Kanakapura Road Bengaluru -560082 Karnataka Karnataka India
(31) Priority Document No	:NA	(72) Name of Inventor :
(32) Priority Date	:NA	1)Dr. Narendra Reddy
(33) Name of priority country	:NA	2)Dr. Uma Ullas Pradhan
(86) International Application No	:NA	
Filing Date	:NA	
(87) International Publication No	: NA	
(61) Patent of Addition to Application Number	:NA	
Filing Date	:NA	
(62) Divisional to Application Number	:NA	
Filing Date	:NA	

(57) Abstract :

A PROCESS OF RECOVERING SERICIN FROM SILK DEGUMMING WASTE SOLUTION USING AN ELECTROCHEMICAL CELL The invention discloses a process of recovering sericin from silk degumming waste solution using an electrochemical cell. The electrochemical cell comprises at least two electrodes, electrochemical cells is operated using DC or AC, and maintained at a particular pH, wherein the electrochemical cellTMs recovery time of sericin is between 15 minutes and 24 hours. The process is highly efficient, low cost and industrially scalable. Further, the invention provides an electrochemical sericin recovery system (100) for recovering sericin from silk degumming waste solution.

No. of Pages : 20 No. of Claims : 8

(12) PATENT APPLICATION PUBLICATION

(21) Application No.202141021547 A

(19) INDIA

(22) Date of filing of Application :12/05/2021

(43) Publication Date : 11/06/2021

(54) Title of the invention : ENSURING NUTRITIONAL VALUE OF FOOD PRODUCTS FROM MANUFACTURERS TO CONSUMERS USING WIRELESS SENSOR NETWORKS AND BLOCKCHAIN TECHNOLOGY

(51) International classification	:B65D0043020000, G09B0019000000, G06Q0030000000, G09B0005020000, A23L0003350800	(71)Name of Applicant : 1)Anitha Rajakumari P Address of Applicant :Research Scholar, SRM Institute of Science and Technology, Delhi-NCR Campus, Ghaziabad- 201204, Uttar Pradesh, India Uttar Pradesh India 2)Dr. Pritee Parwekar 3)Pratyusa Mukherjee 4)Sanjaya Kumar Sarangi 5)Rasmita Lenka 6)Swarnalata Rath 7)Ms. Sana Tak 8)Riya Saini 9)Ritambhara 10)Dr. Nazrul Haq 11)Mr. Dhiraj Kapila 12)Dr.S.Balamurugan
(31) Priority Document No	:NA	(72)Name of Inventor : 1)Anitha Rajakumari P 2)Dr. Pritee Parwekar 3)Pratyusa Mukherjee 4)Sanjaya Kumar Sarangi 5)Rasmita Lenka 6)Swarnalata Rath 7)Ms. Sana Tak 8)Riya Saini 9)Ritambhara 10)Dr. Nazrul Haq 11)Mr. Dhiraj Kapila 12)Dr.S.Balamurugan
(32) Priority Date	:NA	
(33) Name of priority country	:NA	
(86) International Application No	:NA	
Filing Date	:NA	
(87) International Publication No	: NA	
(61) Patent of Addition to Application Number	:NA	
Filing Date	:NA	
(62) Divisional to Application Number	:NA	
Filing Date	:NA	

(57) Abstract :

Ensuring Nutritional Value of Food Products from Manufacturers to Consumers Using Wireless Sensor Networks and Blockchain Technology (NVFPMC) helps the consumer to make use of the NVFPMC to ensuring the nutritional value of food products from manufacturers to consumers automatically using bar-code and blockchain technology. Smart farming is used to cultivate food items efficiently with full nutrition values. The food manufacturing factory helps to process the food items into food products without reducing the nutrition values. Then it measures the nutrition values of each food product and labeled them as a bar-code value. Then the food products are kept maintaining in the food storage unit by retailers. Then it will be transferred to supermarkets through appropriate logistics without degrading the nutrition values of food products. The end-user will purchase the food products in the supermarket by ensuring the nutrition values. If any deviation in the nutrition values, then the user may decide to purchase it or not as well as make a complaint about the products. The NVFPMC control unit helps to monitoring and managing the successful functioning of the whole NVFPMC system. By using this NVFPMC, the consumer to make use of the NVFPMC to ensuring the nutritional value of food products from manufacturers to consumers automatically using bar-code and blockchain technology.

No. of Pages : 16 No. of Claims : 3

(12) PATENT APPLICATION PUBLICATION

(21) Application No.202141021548 A

(19) INDIA

(22) Date of filing of Application :12/05/2021

(43) Publication Date : 11/06/2021

(54) Title of the invention : IOT BASED ELDERLY PEOPLE ACTIVITY MONITORING AND DETECTING UNUSUAL ACTIVITY IN HOME

<p>(51) International classification :A61B0005000000, A61B0005020500, G06Q0050220000, H04L0029080000, A61B0005021000</p> <p>(31) Priority Document No :NA</p> <p>(32) Priority Date :NA</p> <p>(33) Name of priority country :NA</p> <p>(86) International Application No :NA Filing Date :NA</p> <p>(87) International Publication No : NA</p> <p>(61) Patent of Addition to Application Number :NA Filing Date :NA</p> <p>(62) Divisional to Application Number :NA Filing Date :NA</p>	<p>(71)Name of Applicant :</p> <p>1)Dr. S. JAGAN Address of Applicant :Associate Professor, Department of Computer Science and Engineering, Vel Tech Rangarajan Dr.Sagunthala R&D Institute of Science and Technology, No.42, Avadi-Vel Tech Road, Poonamallee - Avadi High Road, Vel Nagar, Chennai-600062, India. Ph: 9498041938 E-Mail: jaganshanmugam83@gmail.com Tamil Nadu India</p> <p>2)Mr. A. THIYAGARAJAN</p> <p>3)Mrs. M. REVATHI</p> <p>4)C.P. JETLIN</p> <p>5)Dr. K. DEEPA THILAK</p> <p>6)Dr. K. KALAISELVI</p> <p>7)Dr. K. GURUNATHAN</p> <p>8)Dr. M. UMASELVI</p> <p>9)Dr. N. KALYANA SUNDARAM</p> <p>10)N. NAGARAJAN</p> <p>(72)Name of Inventor :</p> <p>1)Dr. S. JAGAN</p> <p>2)Mr. A. THIYAGARAJAN</p> <p>3)Mrs. M. REVATHI</p> <p>4)C.P. JETLIN</p> <p>5)Dr. K. DEEPA THILAK</p> <p>6)Dr. K. KALAISELVI</p> <p>7)Dr. K. GURUNATHAN</p> <p>8)Dr. M. UMASELVI</p> <p>9)Dr. N. KALYANA SUNDARAM</p> <p>10)N. NAGARAJAN</p>
---	--

(57) Abstract :

ABSTRACT OF THE INVENTION An IoT enabled cloud-based system consists of two components namely Smart Health device and wireless sensor devices to monitor the elder people™s health condition and unusual activity continuously at home. It enables the user to keep track the elder people™s health activities and support them dynamically without medical people or family members. The smart health device monitors the elder people™s health parameters such as heart rate, oxygen level and blood pressure whereas medical wireless sensor device senses the elder people™s unusual activities like falling down, breathing problem, sudden changes in the physical body, body temperature etc. The message notification will be sent by the IoT based cloud system to the concerned hospital people and family members immediately once if the above said unusual activities and health parameters cross its beyond the threshold limit. In this way, the automated IoT based Cloud system enables the user to keep track the health condition and any unusual activity continuously without any human support and thus an elder people is managed in cost-effective manner.

No. of Pages : 11 No. of Claims : 5

(12) PATENT APPLICATION PUBLICATION

(21) Application No.202141021560 A

(19) INDIA

(22) Date of filing of Application :12/05/2021

(43) Publication Date : 11/06/2021

(54) Title of the invention : A CONTINUOUS NON-RADIATIVE ELECTRICAL IMPEDANCE TOMOGRAPHY COMPUTATION SYSTEM FOR NEONATAL BRAIN CARE

<p>(51) International classification</p> <p>(31) Priority Document No</p> <p>(32) Priority Date</p> <p>(33) Name of priority country</p> <p>(86) International Application No Filing Date</p> <p>(87) International Publication No</p> <p>(61) Patent of Addition to Application Number Filing Date</p> <p>(62) Divisional to Application Number Filing Date</p>	<p>:A61B0005053000, A61B0005000000, G01N0027020000, G01R0033480000, G01T0001290000</p> <p>:NA</p> <p>:NA</p> <p>:NA</p> <p>:NA</p> <p>:NA</p> <p>:NA</p> <p>:NA</p> <p>:NA</p> <p>:NA</p> <p>:NA</p>	<p>(71)Name of Applicant :</p> <p>1)Dr KVSSSS Sairam Address of Applicant :Professor, Department of E&C, NMAMIT NITTE, (Autonomous and Affiliated to VTU, BELAGAVI), Karkala Taluk, Udupi District, Karnataka- 574110 Karnataka India</p> <p>2)Dr. Hiren Madhukar Dekate</p> <p>3)Dr N Saranya</p> <p>4)Dr Sudharsan Jayabalan</p> <p>5)Dr.Ragavanantham Shanmugam</p> <p>6)Dr.G.Naga Rama Devi</p> <p>7)Dr Muralidharan J</p> <p>8)Ms.Vishakha V Jogdand</p> <p>9)Mr. Tej Sai Ram Janapaala</p> <p>10)Mr.Om Prakash Singh</p> <p>11)Mr.Abhisek Saha</p> <p>12)Dr . K Sreenivasulu</p> <p>(72)Name of Inventor :</p> <p>1)Dr KVSSSS Sairam</p> <p>2)Dr. Hiren Madhukar Dekate</p> <p>3)Dr N Saranya</p> <p>4)Dr Sudharsan Jayabalan</p> <p>5)Dr.Ragavanantham Shanmugam</p> <p>6)Dr.G.Naga Rama Devi</p> <p>7)Dr Muralidharan J</p> <p>8)Ms.Vishakha V Jogdand</p> <p>9)Mr. Tej Sai Ram Janapaala</p> <p>10)Mr.Om Prakash Singh</p> <p>11)Mr.Abhisek Saha</p> <p>12)Dr . K Sreenivasulu</p>
--	--	---

(57) Abstract :

Electrical impedance tomography is an interesting issue. For the most recent couple of many years, it is another imaging strategy and has advanced throughout. Voltages are taken by infusing a modest quantity of flow and the electrical properties of tissues are resolved and estimations are made. These voltages changed into a tomographic picture by utilizing a recreating calculation. When contrasted with attractive reverberation imaging and figured tomography examines electrical impedance tomograph contains no distinguished dangers and, it is less expensive. In this invention, to improve this innovation and the part of man-made consciousness the thorough audit of progressions and endeavors accomplished and embraced in ongoing work to address this non-straight, not well-presented issue is introduced. A survey of clinical-based applications electrical impedance tomograph has to be introduced.

No. of Pages : 13 No. of Claims : 6

(12) PATENT APPLICATION PUBLICATION

(21) Application No.202141021564 A

(19) INDIA

(22) Date of filing of Application :13/05/2021

(43) Publication Date : 11/06/2021

(54) Title of the invention : SUSTAINING SOLAR DISTILLATION USING ENERGY STORAGE MATERIALS

(51) International classification	:C02F0001040000, C02F0001140000, B01D0005000000, F24S0060300000, B01D0001000000	(71)Name of Applicant : 1)Dr.S.Joe Patrick Gnanaraj Address of Applicant :Associate Professor Department Of Mechanical Engineering Francis Xavier Engineering College Tirunelveli Tamil Nadu India 2)Dr.Zeenathul Farida Abdul Gani Professor, Francis Xavier Engineering College 3)Dr.S.Imran Khan, AP, Wollega University, Ethiopia 4)Dr. Veer P.Gangwar, Professor, Mittal School Of Business Lovely Professional University 5)Mr.Parthiban P, Assistant Professor, Jyothi Engineering College
(31) Priority Document No	:NA	(72)Name of Inventor : 1)Mr. S.Mayakannan, AP, Vidya Vikas College of Engineering and Technology 2)R. Girimurugan, AP, Nandha College of Technology 3)Mr. E. Manohar, Associate Professor, Francis Xavier Engineering College 4)Ms. P. Leela Jancy, Assistant Professor, Sri Sai Ram Institute of Technology
(32) Priority Date	:NA	
(33) Name of priority country	:NA	
(86) International Application No	:NA	
Filing Date	:NA	
(87) International Publication No	: NA	
(61) Patent of Addition to Application Number	:NA	
Filing Date	:NA	
(62) Divisional to Application Number	:NA	
Filing Date	:NA	

(57) Abstract :

The invention is about water distillation using solar energy which is a non-conventional source of energy widely used nowadays. Here distillation is carried by means of energy storage materials such as bricks, granite, tiles, cement blocks, etc. These materials have the capacity to store heat, hence serves as a perfect alternate for the emerging water demand. The system comprises a stand to hold any of the above said materials which are covered by glass cover to obtain or hold maximum sun rays. There is a collection tank to collect the distilled water. The receiving end is sloped for easier collection of the distillate, thereby the impurities remain underneath.

No. of Pages : 14 No. of Claims : 5

(54) Title of the invention : KADAPPA STONE WATER PURIFIER SYSTEM

<p>(51) International classification :C02F0001140000, C02F0009000000, C02F0001000000, C02F0001040000, B28D0007040000</p> <p>(31) Priority Document No :NA (32) Priority Date :NA (33) Name of priority country :NA (86) International Application No :NA Filing Date :NA (87) International Publication No : NA (61) Patent of Addition to Application Number:NA Filing Date :NA (62) Divisional to Application Number :NA Filing Date :NA</p>	<p>(71)Name of Applicant : 1)Dr.S.JOE PATRICK GNANARAJ Address of Applicant :Associate Professor Department of Mechanical Engineering Francis Xavier engineering college Tirunelveli Tamil Nadu India 2)DR S RAMACHANDRAN, Professor & Head, CMR Institute of Technology 3)Dr.P.Prakash, AP, University college of engineering, Villupuram 4)Mr.A.Ramesh Udhayakumar, Assoc. Prof, Misrimal Navajee Munoth Jain Engineering College 5)Dr.N.S.Balaji, Post Doctoral Fellow, NIT, Trichy</p> <p>(72)Name of Inventor : 1)Dr.Zeenathul Farida Abdul Gani, Prof., Francis Xavier engineering college 2)Mr.A.RAMESH UDHAYAKUMAR, ASSOCIATE PROFESSOR, MISRIMAL NAVAJEE MUNOTH JAIN ENGINEERING COLLEGE 3)Dr.N.S.Balaji, Post Doctoral Fellow, NIT, Trichy 4)Mr. C.T. Justus Panicker, Research scholar, NIT,Trichy 5)Mr.R.Shishir, Research scholar, NIT, Trichy 6)Dr.P.Prakash, AP, University college of engineering, Villupuram</p>
--	--

(57) Abstract :

In this period of increasing demands over purified water, the proposed Kadappa stone based solar distillation system is an efficient product to produce distilled water. The system comprises of a basin comprising unpurified water. saw dust and wick materials in this water performs initial filtration of the impurities. This filtered water is subjected to capture solar energy by means of Kadappa stone at the top surface covered with glass cover. There are collection trays on either sides for collecting the pure distillate. The entire setup is kept on a stand. Hence by means of the non-conventional source of energy distillation is performed.

No. of Pages : 15 No. of Claims : 5

(12) PATENT APPLICATION PUBLICATION

(21) Application No.202141021578 A

(19) INDIA

(22) Date of filing of Application :13/05/2021

(43) Publication Date : 11/06/2021

(54) Title of the invention : Real Time Monitoring of Water Quality Parameters in Aquaculture and Automation of Aerators Based System Using IoT

(51) International classification	:A01K0063040000, A01K0063000000, B01F0003040000, C02F0003200000, A01K0061000000	(71) Name of Applicant : 1)Dr. Kumar Raja D R Address of Applicant :Associate Professor School of C & IT REVA University Bengaluru Karnataka India
(31) Priority Document No	:NA	(72) Name of Inventor :
(32) Priority Date	:NA	1)Dr. Kumar Raja D R
(33) Name of priority country	:NA	2)Dr. G Parthasarathy
(86) International Application No	:PCT//	3)Dr. Mallikarjun M. Kodabagi
Filing Date	:01/01/1900	4)G Hemanth Kumar
(87) International Publication No	: NA	5)Dr. P Ramesh
(61) Patent of Addition to Application Number	:NA	
Filing Date	:NA	
(62) Divisional to Application Number	:NA	
Filing Date	:NA	

(57) Abstract :

In the traditional aquaculture model, the farmer does not know the level of oxygen in the water and has to go to the pond to manually turn on the aerator. Sometimes there may be a delay in turning on the aerators. This leads to a lack of oxygen in the pond, with serious consequences. As the water temperature rises, the metabolic rate of the fish improves and the amount of oxygen in the water decreases which causes the growth of .Low water temperatures reduce the frequency of fish spawning and increase the amount of oxygen in the water. In aquaculture, the pH value is an essential measure of the acidity of the water or the soil. Fish can no longer survive in water pH below 4 and pH above 11. The optimal pH value for fish is from 6.5 to 9. The fish grows poorly and their reproduction is impaired by higher or lower pH values. The development of smart aquaculture is possible only with the help of sensors and requires precise control of devices, in such cases sensors play an important role. The smart aquaculture system uses a sensor to acquire the information about various parameters. Based on information of parameters such as water temperature, pH value and dissolved oxygen, as well as predefined thresholds this information is transmitted to a microcontroller that can take action according to a threshold levels, and the action taken by the controller can change the state of the aeration device and transmit the status directly to the farmer's mobile phone.

No. of Pages : 8 No. of Claims : 3

(54) Title of the invention : AUTONOMOUS WHEELCHAIR ASSISTED SPEECH RECOGNITION SYSTEM FOR PHYSICALLY CHALLENGED ONES

<p>(51) International classification</p> <p>(31) Priority Document No</p> <p>(32) Priority Date</p> <p>(33) Name of priority country</p> <p>(86) International Application No Filing Date</p> <p>(87) International Publication No</p> <p>(61) Patent of Addition to Application Number Filing Date</p> <p>(62) Divisional to Application Number Filing Date</p>	<p>:A61G0005100000, A61G0005120000, A61G0003060000, A61G0005040000, A61G0005140000</p> <p>:NA</p> <p>:NA</p> <p>:NA</p> <p>:NA</p> <p>:NA</p> <p>: NA</p> <p>:NA</p> <p>:NA</p> <p>:NA</p> <p>:NA</p>	<p>(71)Name of Applicant :</p> <p>1)Dr. V.S.AKSHAYA Address of Applicant :HEAD HIGHER STUDIES & INTERNATIONAL RELATIONS, PROFESSOR, DEPARTMENT OF COMPUTER SCIENCE AND ENGINEERING, SRI ESHWAR COLLEGE OF ENGINEERING, VADASITHUR, KINATHUKADAVU - KATTAMPATTI RD, KONDAMPATTY, TAMIL NADU 641202 Tamil Nadu India</p> <p>2)Ms.P.CHITRA</p> <p>3)Dr. M. VARGHEESE</p> <p>4)Ms. N. GAYATHRI</p> <p>5)Ms. G. PRIYANKA</p> <p>6)Dr. G. NALLASIVAN</p> <p>7)Dr. N. YUVARAJ</p> <p>8)Mr. R. ARSHATH RAJA</p> <p>9)Dr. M. RAMKUMAR</p> <p>(72)Name of Inventor :</p> <p>1)Dr. V.S.AKSHAYA</p> <p>2)Ms.P.CHITRA</p> <p>3)Dr. M. VARGHEESE</p> <p>4)Ms. N. GAYATHRI</p> <p>5)Ms. G. PRIYANKA</p> <p>6)Dr. G. NALLASIVAN</p> <p>7)Dr. N. YUVARAJ</p> <p>8)Mr. R. ARSHATH RAJA</p> <p>9)Dr. M. RAMKUMAR</p>
--	---	---

(57) Abstract :

The autonomous wheelchairs tend to extend their operations with conventional devices that help in navigation and controlled movements. Autonomous wheelchairs enable the lives of physically challenged ones with severe impairments to increase their mobility range. With the assistance of either hand or legs, the wheelchairs can be operated to their target distance. However, people with disability on both hand and legs make the operation of wheelchair difficult. It is hence necessary for such persons to manually control the wheelchair with their voices. In this proposal, we develop a speech-assisted wheelchair device that automatically controls the movement of it. It can either be controlled manually or automatically, where the disabled ones are placed over it. With the help of an accelerometer, the movements can be made and with their voice assistant, the destination can be set.

No. of Pages : 15 No. of Claims : 8

(12) PATENT APPLICATION PUBLICATION

(21) Application No.202141021635 A

(19) INDIA

(22) Date of filing of Application :13/05/2021

(43) Publication Date : 11/06/2021

(54) Title of the invention : DESIGN OF SQUARE CROSS SECTION FRAME BICYCLE

<p>(51) International classification</p> <p>(31) Priority Document No</p> <p>(32) Priority Date</p> <p>(33) Name of priority country</p> <p>(86) International Application No Filing Date</p> <p>(87) International Publication No</p> <p>(61) Patent of Addition to Application Number Filing Date</p> <p>(62) Divisional to Application Number Filing Date</p>	<p>:B62K0019020000, B62M0009020000, B62M0001260000, B62K0017000000, F16C0033340000</p> <p>:NA</p> <p>:NA</p> <p>:NA</p> <p>:NA</p> <p>:NA</p> <p>: NA</p> <p>:NA</p> <p>:NA</p> <p>:NA</p> <p>:NA</p> <p>:NA</p>	<p>(71)Name of Applicant :</p> <p>1)Mr.BOKKA TEJA VENKATESH Address of Applicant :DEPARTMENT OF MECHANICAL ENGINEERING, MARRI LAXMAN REDDY INSTITUTE OF TECHNOLOGY AND MANAGEMENT, DUNDIGAL, HYDERABAD 500 043, TELANGANA, INDIA Telangana India</p> <p>2)Mr.KRANTHI KUMAR SINGAM</p> <p>3)Mr.U.SUDHAKAR</p> <p>4)Dr. JANI.S.P</p> <p>5)Mr.KARRI THARUN KUMAR</p> <p>6)Mr.THATIPERTHI TARUN GOPI</p> <p>7)Ms.SRIRLA MOUNIKA</p> <p>8)Mr.MENGU VIJAY JOHN</p> <p>9)Ms.K.SRAVANTHI</p> <p>10)Dr. P.SENTHIL KUMAR</p> <p>(72)Name of Inventor :</p> <p>1)Mr.BOKKA TEJA VENKATESH</p> <p>2)Mr.KRANTHI KUMAR SINGAM</p> <p>3)Mr.U.SUDHAKAR</p> <p>4)Dr. JANI.S.P</p> <p>5)Mr.KARRI THARUN KUMAR</p> <p>6)Mr.THATIPERTHI TARUN GOPI</p> <p>7)Ms.SRIRLA MOUNIKA</p> <p>8)Mr.MENGU VIJAY JOHN</p> <p>9)Ms.K.SRAVANTHI</p> <p>10)Dr. P.SENTHIL KUMAR</p>
--	--	---

(57) Abstract :

ABSTRACT DESIGN OF SQUARE CROSS SECTION FRAME - BICYCLE This patent disclosure covers the design and development of bicycle frame which is useful for both urban and trek purpose. The cross sectional design is inspired by Beams of buildings and compared to circular cross section square cross section have more moment of inertia which reduces the stress developed in it i.e. bending stress. The utilization of material type known plans and designs is known in the earlier workmanship. The plans and arrangements recently contrived and used to slaughter different sorts of defects and variations by ordinary techniques and contraptions are known to comprise fundamentally of recognizable, expected, and evident underlying setups, despite the bunch of plans incorporated by the swarmed earlier craftsmanship which has been created for the satisfaction of innumerable goals and necessities. Triangular frame is chosen to be favorable for center of gravity. Joints are mostly preferred to concentrate and distribute more load uniformly. The design of bicycle frame gives the robust effect. Chain and sprocket mechanism is used for the operation of power transmission that enhances the required pedal stroke rotations. Based on urban cycles this modal would attract present generation for its ultra-stylish robust frame.

No. of Pages : 10 No. of Claims : 7

(12) PATENT APPLICATION PUBLICATION

(21) Application No.202141021636 A

(19) INDIA

(22) Date of filing of Application :13/05/2021

(43) Publication Date : 11/06/2021

(54) Title of the invention : SYSTEM AND METHOD OF PRODUCING BIOGAS USING ORGANIC WASTE FOR HOUSEHOLD PURPOSE

(51) International classification	:C12P0005020000, C12M0001107000, C12M0001000000, C05F0017500000, C02F0011040000	(71) Name of Applicant : 1)Dr.M.DEVI Address of Applicant :PROFESSOR, DEPARTMENT OF CIVIL ENGINEERING, VIVEKANANDHA COLLEGE OF TECHNOLOGY FOR WOMEN, ELAYAMPALAYAM , TIRUCHENGODE TK, NAMAKKAL DISTRICT,TAMIL NADU 637 205 Tamil Nadu India 2)Dr.M.M.SARAVANAN 3)Mr.A.ANANTHAKUMAR 4)Dr.C.G.DEEPANRAJ 5)Mr.G.VISWANATHAN 6)Mr.S.PANNEERSELVAM
(31) Priority Document No	:NA	(72)Name of Inventor : 1)Dr.M.DEVI 2)Dr.M.M.SARAVANAN 3)Mr.A.ANANTHAKUMAR 4)Dr.C.G.DEEPANRAJ 5)Mr.G.VISWANATHAN 6)Mr.S.PANNEERSELVAM
(32) Priority Date	:NA	
(33) Name of priority country	:NA	
(86) International Application No	:NA	
Filing Date	:NA	
(87) International Publication No	: NA	
(61) Patent of Addition to Application Number:	NA	
Filing Date	:NA	
(62) Divisional to Application Number	:NA	
Filing Date	:NA	

(57) Abstract :

ABSTRACT SYSTEM AND METHOD OF PRODUCING BIOGAS USING ORGANIC WASTE FOR HOUSEHOLD PURPOSE
Biogas is an old approach and creating innovation in late energy patterns. Food squanders having high capability of biogas creation if appropriately blended in with cow compost in view of rich nitrogen and sugars content. Food squanders are effectively accessible; more than 150 tons of food squander are unloaded into ground each day. This task assessed that combination of food squander with cow fertilizer gives required nature of biogas and day by day feed of a similar will give great biogas yield and we can save the LPG utilization gracious family applications and give the loss as compost to cultivating. The test outcomes give that the food squander blended in with cow excrement for creating biogas gives 5.32 % of expanded methane content than the methane got from the Cow compost alone. The charging of Food squander alone delivers biogas which is 5.9 % lesser methane content than the methane acquired from the biogas from cow fertilizer. It is better that the biogas created from blending of food squander alongside cow fertilizer delivers better nature of biogas when contrasted and just cow gung or just food squander as the feed.

No. of Pages : 22 No. of Claims : 5

(12) PATENT APPLICATION PUBLICATION

(21) Application No.202141021654 A

(19) INDIA

(22) Date of filing of Application :13/05/2021

(43) Publication Date : 11/06/2021

(54) Title of the invention : PERFORMANCE OPTIMIZATION OF RECONFIGURABLE MANUFACTURING SYSTEM USING DUAL STEP METAHEURISTIC APPROACH

(51) International classification	:G06Q0010040000, G06Q0050060000, G06Q0010060000, G06F0111060000, G06F0030170000	(71) Name of Applicant : 1)Suresh Babu G Address of Applicant :Research Scholar & Assistant Professor Mechanical Engineering VTU RRC, VTU PG Center, Muddenahalli, Chickballapur, 562101 Annamacharya Institute of Technology & Sciences, New Boayanapalli, Rajampet, 516126 sureshbabuhere@gmail.com 9949224453 Karnataka India
(31) Priority Document No	:NA	2)Dr N Chikkanna
(32) Priority Date	:NA	3)Puneet Shetteppanavar
(33) Name of priority country	:NA	(72) Name of Inventor :
(86) International Application No	:NA	1)Suresh Babu G
Filing Date	:NA	2)Dr N Chikkanna
(87) International Publication No	: NA	3)Puneet Shetteppanavar
(61) Patent of Addition to Application	:NA	
Number	:NA	
Filing Date	:NA	
(62) Divisional to Application Number	:NA	
Filing Date	:NA	

(57) Abstract :

TITLE OF INVENTION: Performance Optimization of Reconfigurable Manufacturing System Using Dual Step Metaheuristic Approach
Field of Invention: Mechanical Engineering
ABSTRACT Reconfigurable manufacturing system aka RMS is a novice topology in manufacturing sector that is designed in accordance with the product requirement, however re-configurability is considered as the non-functional system requirement and it is long term behavior. Thus considering the conventional approach dynamic change is highly improbable; hence it is necessary to design the model that has the dynamic change capacity. In this Invention, we have developed (DSMO) dual step metaheuristic optimized approach to solve the two distinctive problem; in first step we optimize the product changes reaction. In second step, we develop the optimized layout for machine selection by optimizing the machine floor arrangement and position of machine. Further dual step mechanism is evaluated through comparison analysis with the existing model of ANC90. Moreover, evaluation is performed by considering two cases adopted from the existing model; in case 1 cost comparison has been carried out whereas in case 2 re-configuration cost, total cost and capital cost are compared. Further comparison has been carried out considering the various scenarios in both cases and comparative analysis indicates that proposed methodologies simply outperforms the existing model.

No. of Pages : 11 No. of Claims : 1

(12) PATENT APPLICATION PUBLICATION

(21) Application No.202141021675 A

(19) INDIA

(22) Date of filing of Application :13/05/2021

(43) Publication Date : 11/06/2021

(54) Title of the invention : THE COGNITIVE LINGUISTIC MODEL FOR LITERARY TEXT ANALYTICS

(51) International classification	:G06F0040300000, G06F0040205000, G09B0019060000, G09B0017000000, G06F0016330000	(71) Name of Applicant : 1)Dr. Bavani Rekha A Address of Applicant :Designation: Assistant Professor Department: English Institution address: Women's Christian College, Chennai. Email id: bavanirekha@wcc.edu.in Mobile No: 9942441864 Tamil Nadu India
(31) Priority Document No	:NA	2)Dr. N. Ayyanathan
(32) Priority Date	:NA	3)Puneet Shetteppanavar
(33) Name of priority country	:NA	(72) Name of Inventor :
(86) International Application No	:NA	1)Dr. Bavani Rekha A
Filing Date	:NA	2)Dr. N. Ayyanathan
(87) International Publication No	: NA	3)Puneet Shetteppanavar
(61) Patent of Addition to Application Number:	NA	
Filing Date	:NA	
(62) Divisional to Application Number	:NA	
Filing Date	:NA	

(57) Abstract :

Page 1 of 1 TITLE: THE COGNITIVE LINGUISTIC MODEL FOR LITERARY TEXT ANALYTICS ABSTRACT Cognitive Linguistic model interprets the given literary text at the linguistic, literary and aesthetic level. Natural language Processing is applied to assess the interpreting skills of the literary text with the help of the proposed content specification of Cognitive Linguistics. Furthermore, the Cognitive Linguistic model observes the learnerTMs strengths and weaknesses using Schema theory to develop the reading comprehension of the literary text with the assessment metrics designed in Content Specification of Cognitive Linguistics

No. of Pages : 13 No. of Claims : 1

(12) PATENT APPLICATION PUBLICATION

(21) Application No.202141021703 A

(19) INDIA

(22) Date of filing of Application :13/05/2021

(43) Publication Date : 11/06/2021

(54) Title of the invention : MODEL PREDICTIVE CURRENT CONTROL OF SINGLE-PHASE 9-LEVEL REDUCED SWITCH MULTILEVEL INVERTER

(51) International classification	:H02M0007483000, H02J0003010000, G05B0013040000, H02J0003180000, H02M0007797000	(71) Name of Applicant : 1)Dr.K.Rameshkumar Address of Applicant :Assistant Professor, Dept. of Electrical and Electronics Engineering, Dr. Mahalingam College of Engineering and Technology, Pollachi. Tamil Nadu India 2)Dr. A.Senthilkumar 3)Dr. M.Kaliamoorthy 4)Mr. P. Kathirvel 5)Mr.A.Maideen Abdhulkader Jeylani
(31) Priority Document No	:NA	(72) Name of Inventor :
(32) Priority Date	:NA	1)Dr.K.Rameshkumar
(33) Name of priority country	:NA	2)Dr. A.Senthilkumar
(86) International Application No	:NA	3)Dr. M.Kaliamoorthy
Filing Date	:NA	4)Mr. P. Kathirvel
(87) International Publication No	: NA	5)Mr.A.Maideen Abdhulkader Jeylani
(61) Patent of Addition to Application Number	:NA	
Filing Date	:NA	
(62) Divisional to Application Number	:NA	
Filing Date	:NA	

(57) Abstract :

In this work, a Model Predictive Current Control (MPCC) of single-phase 9-level reduced switch Multilevel Inverter (MLI) has been proposed for improving power quality. The discrete model of the system is used to predict the future load current for each possible switching state at every sampling instant. For every sampling instant, the controller estimates the cost function. The switching state which reduces the cost function is chosen and applied to the MLI. This invention evaluated in terms of Total Harmonic Distortion (THD) and reference current tracking. The effectiveness of the proposed current control method has been validated by MATLAB/Simulink environment. The obtained results shows that the proposed current control method perform well in steady state and dynamic operating conditions.

No. of Pages : 6 No. of Claims : 8

(12) PATENT APPLICATION PUBLICATION

(21) Application No.202141021727 A

(19) INDIA

(22) Date of filing of Application :13/05/2021

(43) Publication Date : 11/06/2021

(54) Title of the invention : METHOD FOR MANUFACTURING GYPSUM CEMENT COMPOSITE REINFORCED BRICK •

(51) International classification	:C04B0028140000, C04B0111000000, B28B0023000000, B28B0007000000, B29C0070300000	(71) Name of Applicant : 1)M/S. RADHA INDUSTRIES Address of Applicant :NO. 3, E.C.R. ROAD, OPP. PONNUSAMY HOTEL, LAWSPET, PUDUCHERRY - 605008 Pondicherry India
(31) Priority Document No	:NA	(72) Name of Inventor :
(32) Priority Date	:NA	1)Mr. K. PREGASH
(33) Name of priority country	:NA	
(86) International Application No	:NA	
Filing Date	:NA	
(87) International Publication No	: NA	
(61) Patent of Addition to Application Number	:NA	
Filing Date	:NA	
(62) Divisional to Application Number	:NA	
Filing Date	:NA	

(57) Abstract :

ABSTRACT METHOD FOR MANUFACTURING GYPSUM CEMENT COMPOSITE REINFORCED BRICK • manufactures the brick in a simple manner with reduced curing time and also does not require cement plastering for inner wall. The method comprising the steps of: a. forming mold of required size and shape; b. applying releasing agent or oil on inner side of mold; c. mixing calcined gypsum with water in ratio of 100:0.65 and pouring mixture in mold to form first inner gypsum layer (2); d. placing glass fibers in ratio of 0.025 on gypsum layer before setting of the gypsum layer to form middle glass fiber reinforcement layer (3); e. mixing fly ash or sand, lime, cement and calcined gypsum in ratio of 69:20:8:3 one by one or as whole in water at ratio of 0.65 and in aluminum powder at ratio of 0.08 and pouring prepared mixture on glass fiber layer before setting of gypsum and glass fiber layers to form outer cement layer (1); f. removing brick consisting of cement layer, gypsum layer and glass fiber reinforcement layer, from mold after curing process; g. drying removed brick naturally or artificially in heating room, pre-curing process, auto-clave process, etc.; h. wire cutting gypsum cement brick (GCB) in case of requirements; and i. subjecting brick to curing process naturally or artificially based on weather conditions. Refer Figure 1

No. of Pages : 19 No. of Claims : 10

(54) Title of the invention : A SMART IOT BASED INSTANT TOXIC CONTENT DETECTION SYSTEM

<p>(51) International classification</p> <p>(31) Priority Document No</p> <p>(32) Priority Date</p> <p>(33) Name of priority country</p> <p>(86) International Application No</p> <p style="padding-left: 20px;">Filing Date</p> <p>(87) International Publication No</p> <p>(61) Patent of Addition to Application Number</p> <p style="padding-left: 20px;">Filing Date</p> <p>(62) Divisional to Application Number</p> <p style="padding-left: 20px;">Filing Date</p>	<p>(71)Name of Applicant :</p> <p>1)Mr. Arun R Address of Applicant :Assistant Professor, Department of Computer Science and Engineering, Hindusthan Institute of Technology, Othakalmandapam PO Coimbatore 641032. Tamil Nadu India</p> <p>2)Ms.S. Priyadarshini</p> <p>3)Dr.P.Selvaraj</p> <p>4)Dr K.Madhivanan</p> <p>5)Dr Velmurugan J</p> <p>6)Dr. Chandra Prakash Lora</p> <p>7)Dr. A.Jebaraj Ratnakumar</p> <p>8)Dr.S.Balakrishnan</p> <p>(72)Name of Inventor :</p> <p>1)Mr. Arun R</p> <p>2)Ms.S. Priyadarshini</p> <p>3)Dr.P.Selvaraj</p> <p>4)Dr K.Madhivanan</p> <p>5)Dr Velmurugan J</p> <p>6)Dr. Chandra Prakash Lora</p> <p>7)Dr. A.Jebaraj Ratnakumar</p> <p>8)Dr.S.Balakrishnan</p>
---	--

(57) Abstract :

With the rapid development of Indian industrial production, the unique physical of gas in the process of food storage, frozen foods, inflatable packaging, special fuel production, hyperbaric oxygen therapy and the production of chemical products such as human organs. And chemical properties have been widely used. We can see that gas occupies a very important place in human life and the national economy. However, widespread use of gas inevitably leads to the problem of toxic gas leaks. Gas leakage can be easily detected and controlled by applying internet of things-based system. In this work, we are using Arduino Microcontroller which is used to monitor harmful gases and also to intimate alert message to safety control board of industry. Arduinio Microcontroller board is used as central microcontroller which is connected with sensor. LPG gas detector system senses the LPG gas using MQ2 gas sensor. Butane gas is odorless, colorless, and highly flammable at room temperature, and causes serious health effects when inhaled directly. MQ2 is also useful for detecting H2, LPG, CH4, CO, Alcohol, Smoke or Propane. A gas sensor is a device which detects the presence or concentration of gases in the atmosphere. Based on the concentration of the gas the sensor produces a corresponding potential difference by changing the resistance of the material inside the sensor, which can be measured as output voltage. Alcohol sensor (MQ3) which can detect the presence of alcohol gases at concentrations from 0.05 mg/L to 10 mg/L.

No. of Pages : 6 No. of Claims : 4

(12) PATENT APPLICATION PUBLICATION

(21) Application No.202141021737 A

(19) INDIA

(22) Date of filing of Application :13/05/2021

(43) Publication Date : 11/06/2021

(54) Title of the invention : A METHOD AND A SYSTEM FOR PROVIDING A SINGLE CROSS PLATFORM MOBILE APPLICATION TO DELIVER ON DEMAND IMMERSIVE CONTENTS

(51) International classification	:H04N0021630000, H04L0001000000, G06F0011360000, H04L0001180000, G06F0008100000	(71) Name of Applicant : 1)3RDFLIX VISUAL EFFECTS PRIVATE LIMITED Address of Applicant :SY NO 37/A 37P, PLOT NO. 6P, 2-91/77/2/ST/2 2ND FLOOR, SIGNATURE TOWERS, KONDAPUR, HYDERABAD, TELANGANA 500084 INDIA Telangana India
(31) Priority Document No	:NA	(72) Name of Inventor :
(32) Priority Date	:NA	1)Subbarao Siddabattula
(33) Name of priority country	:NA	2)Arpita Saxena
(86) International Application No	:PCT//	3)Rusheel Sandri
Filing Date	:01/01/1900	
(87) International Publication No	: NA	
(61) Patent of Addition to Application Number	:NA	
Filing Date	:NA	
(62) Divisional to Application Number	:NA	
Filing Date	:NA	

(57) Abstract :

ABSTRACT A METHOD AND A SYSTEM FOR PROVIDING A SINGLE CROSS PLATFORM MOBILE APPLICATION TO DELIVER ON DEMAND IMMERSIVE CONTENTS A method (200) for providing a single cross platform mobile application to deliver on demand immersive contents, comprises processors which are coupled to a non-transitory storage device and operable to perform the steps of providing (210) platform specific data in a pipeline in a gaming platform; providing (220) a cross platform framework to stipulate a library; providing (230) a data encapsulated module of the gaming platform which resides inside the cross platform framework, tracking (240) the platform specific data using the cross platform framework, encrypting each platform specific data to generate references for the respective platform specific data and passing the generated references to the data encapsulated module, invoking (250) the data encapsulated module of the gaming platform using native side on demand, to render the platform specific data corresponding to the references and deliver immersive content based on each reference, and displaying and manipulating (260) the delivered immersive content. [Figure 2]

No. of Pages : 27 No. of Claims : 14

(12) PATENT APPLICATION PUBLICATION

(21) Application No.202141021773 A

(19) INDIA

(22) Date of filing of Application :14/05/2021

(43) Publication Date : 11/06/2021

(54) Title of the invention : PHASE SHIFTING TRANSFORMER APPLICATION TO REDUCE POWER CONGESTION AND LOOP FLOWS IN INTERCONNECTED POWER SYSTEMS

(51) International classification	:H02J0003060000, H02J0003380000, G06Q0050060000, H02J0003180000, H02J0003000000	(71) Name of Applicant : 1)Ananda M H Address of Applicant :Ananda M H Scholar, V.T.U/ Assistant professor, School of Electrical and Electronics Engineering, REVA University, Rukmini knowledge park, kattigenahalli, Yelahanka, Bengaluru, 560064 Karnataka,India Karnataka India
(31) Priority Document No	:NA	2)Dr. M.R. Shivakumar
(32) Priority Date	:NA	(72) Name of Inventor :
(33) Name of priority country	:NA	1)Ananda M H
(86) International Application No	:NA	2)Dr. M.R. Shivakumar
Filing Date	:NA	
(87) International Publication No	: NA	
(61) Patent of Addition to Application Number	:NA	
Filing Date	:NA	
(62) Divisional to Application Number	:NA	
Filing Date	:NA	

(57) Abstract :

The exaggerated penetration of wind and solar power, and also the liberalized electricity market making the power system network interconnected and complex. As the power demand is increasing day by day the complexity of operating large power system is also increasing. Congestion within the transmission grid could be a development that is encountered additional usually than before, and so power flow management is a difficulty that becomes progressively vital. Unexpected power flows (also called loop flows) are an increasing problem within the interconnected power systems. These flows will have a detrimental impact on the safe functioning of integrated power networks which will hinder their ability to conduct cross-border trade. This deals with two interconnected parallel power system network and the power flow control by use phase shifting transformer (PST) in between. PSCAD simulation explores that, PSTs installed in the tie-lines have the capability of regulating the power flow, alleviate line overloads, modification parallel line sharing. The results emphasize the importance of PST to facilitate transfer of energy throughout regional transmission interconnection. PST-based power flow management has the potential to manage power congestion while also improving network security.

No. of Pages : 17 No. of Claims : 7

(54) Title of the invention : WIRELESS INTERCOMMUNICATIVE PRODUCT FOR DISCERN MEDICINES IN PHARMACIES USING BLUETOOTH

(51) International classification	:H04W0004800000, G06Q0050220000, A61J0001000000, G16H0020100000, C07H0015040000	(71) Name of Applicant : 1)Sujo Oommen Address of Applicant :Assistant Professor School of Electrical & Electronics Engineering, REVA University, Bangalore-64 Karnataka India 2)Akhil P H 3)Akash V Thabaj 4)Dheeraj S 5)Aman Irshad
(31) Priority Document No	:NA	(72) Name of Inventor : 1)Sujo Oommen 2)Akhil P H 3)Akash V Thabaj 4)Dheeraj S 5)Aman Irshad
(32) Priority Date	:NA	
(33) Name of priority country	:NA	
(86) International Application No	:NA	
Filing Date	:NA	
(87) International Publication No	: NA	
(61) Patent of Addition to Application	:NA	
Number	:NA	
Filing Date	:NA	
(62) Divisional to Application Number	:NA	
Filing Date	:NA	

(57) Abstract :

Smart Technologies plays a promising role in various applications in our daily life ranging from farming, education, governance, automobiles etc. Smart devices, wireless technologies and numerous mobile applications has made man to use technologies at their fingertips. Wireless Technology has also influenced the life style of people and has helped improving the quality of life. Now a days, smart devices have become the need of the hour just because of its monitoring capacity, flexible usage, less maintenance, less power consumption, saving time and energy, faster and timely outputs, safety, security. Interaction between smart devices and mobile and web applications makes it much more attractive, user friendly and flexible as it is compatible with all the mobile and web platforms. The proposed invention is about the usage of such wireless technologies based on Bluetooth that helps in spotting medicines in pharmacies. Pharmacists must carefully process, store, and track an outsized volume of drugs also. This proposed cost effective invention providing a wireless Bluetooth- android based technology that can help in locating the medicines in pharmacies and also helps kept the track of the particular medicine available in the slot which in turn helps in saving time. LEDs are connected to the spots where different medicines are kept. The number of medicines and the names of the medicines along with the spots where they are kept will be fed to the Arduino through a program. The user will also be provided with an option to change the medicine names and their locations accordingly and along with these facilities, can also add a particular medicine to the above list provided that there will be an indicator placed at the location where the medicine is going to be kept. The Proposed system can be modified to be used in libraries for spotting books, in large warehouses to spot a particular product, in parking slots to know the slot of a parked vehicle.

No. of Pages : 15 No. of Claims : 4

(12) PATENT APPLICATION PUBLICATION

(21) Application No.202141021846 A

(19) INDIA

(22) Date of filing of Application :14/05/2021

(43) Publication Date : 11/06/2021

(54) Title of the invention : INTERCONNECTION OF USB DEVICES OVER THE CLOUD

(51) International classification	:H04L0029060000, H04L0029080000, H04L0012280000, H04B0007240000, G06F0021600000	(71) Name of Applicant : 1)Dr. J. VENKATESH Address of Applicant :PROFESSOR, CSE, CHENNAI INSTITUTE OF TECHNOLOGY, SARATHY NAGAR, KUNDRATHUR, CHENNAI-69. Tamil Nadu India
(31) Priority Document No	:NA	2)Dr. R. JANARTHANAN
(32) Priority Date	:NA	3)Dr. CHIRRA KESAVA REDDY
(33) Name of priority country	:NA	4)Mr. V. VISHWA RAJ
(86) International Application No	:NA	(72) Name of Inventor :
Filing Date	:NA	1)Dr. J. VENKATESH
(87) International Publication No	: NA	2)Dr. R. JANARTHANAN
(61) Patent of Addition to Application	:NA	3)Dr. CHIRRA KESAVA REDDY
Number	:NA	4)Mr. V. VISHWA RAJ
Filing Date	:NA	
(62) Divisional to Application Number	:NA	
Filing Date	:NA	

(57) Abstract :

Interconnection of USB devices over the cloud is an essential need of an hour invention as far as data transfer is considered. In the existing mechanism, there is no technique to transfer data between data storage devices without an intermediate device and it is practically impossible to have a device that is compatible with the devices whose data has to be exchanged or transferred. The proposed invention facilitates the transfer of data over the cloud without an intermediate device wherein the two devices will be connected to the cloud server through an authentication and authorization procedure. Thus, the proposed invention will be cost-effective and user friendly along with firewall security for transfer of data and databases between two different devices.

No. of Pages : 15 No. of Claims : 5

(12) PATENT APPLICATION PUBLICATION

(21) Application No.202141021871 A

(19) INDIA

(22) Date of filing of Application :14/05/2021

(43) Publication Date : 11/06/2021

(54) Title of the invention : CAVITIES TO CONTROL BASE FLOWS IN OF HIGH SPEED VEHICLES

(51) International classification	:H04L0012801000, H04W0088080000, H03K0017950000, B01D0029940000, B32B0005180000	(71) Name of Applicant : 1)MOHAMMED ASADULLAH THAKUR Address of Applicant :Professor, Department of Mechanical Engineering, Lords Institute of Engineering and Technology, Survey No. 32, Near Police Academy, Appa Junction, Himayathsagar, Hyderabad, Telangana 500091 Telangana India
(31) Priority Document No	:NA	2)AZEEM HAFIZ P A
(32) Priority Date	:NA	3)HUSSAIN FAYAZ
(33) Name of priority country	:NA	4)MANZOORE ELAHI M SOUDAGAR
(86) International Application No	:NA	(72) Name of Inventor :
Filing Date	:NA	1)MOHAMMED ASADULLAH THAKUR
(87) International Publication No	: NA	2)AZEEM HAFIZ P A
(61) Patent of Addition to Application Number	:NA	3)HUSSAIN FAYAZ
Filing Date	:NA	4)MANZOORE ELAHI M SOUDAGAR
(62) Divisional to Application Number	:NA	
Filing Date	:NA	

(57) Abstract :

Embodiments of the present disclosure are related to control of base flows in the high-speed vehicles using cavities. The cavities in compressible regime can be optimized for a critical diameter, critical depth and critical gap between them. The base flow control apparatus for high-speed vehicle comprising a structure configured in the high-speed vehicle. The structure comprises a solo-cavity to increase base-pressure by pulsating effect, thereby controlling the base flows, and multiple-cavities configured to increase a base pressure by pulsating effect periodically. This periodic excitation happens only in multiple cavities due to the optimization of gap between cavities. By varying gap, the pattern or alignment may be changed, thus controlling periodic excitation for effective control of base flows. The base flow controller increases the base pressure with no input energy. The base flow control in high-speed vehicles eliminates the energy needed to run it, and reduces fuel consumption and operational cost.

No. of Pages : 23 No. of Claims : 9

(54) Title of the invention : BATTERY SWAPPING SMART STATION FOR FUTURE E-VEHICLE TRANSPORTATION

<p>(51) International classification</p> <p>(31) Priority Document No</p> <p>(32) Priority Date</p> <p>(33) Name of priority country</p> <p>(86) International Application No Filing Date</p> <p>(87) International Publication No</p> <p>(61) Patent of Addition to Application Number: Filing Date</p> <p>(62) Divisional to Application Number Filing Date</p>	<p>:B60L0053800000, B60S0005060000, B60L0053300000, H02J0007000000, B60L0053140000</p> <p>:NA</p> <p>:NA</p> <p>:NA</p> <p>:NA</p> <p>:NA</p> <p>:NA</p> <p>:NA</p> <p>:NA</p> <p>:NA</p> <p>:NA</p>	<p>(71)Name of Applicant :</p> <p>1)Dr.T.Vinoth Kumar Address of Applicant :Assistant Professor, Department of Electrical and Electronics Engineering, RVS College of Engineering and Technology, Kumaran kottam campus, Trichy Road, Coimbatore-641402. Tamil Nadu India</p> <p>2)Dr.N.Yogambal Jayalakshmi</p> <p>3)Mr.K.Saravanan</p> <p>4)Dr. C. Vimalraj</p> <p>5)Mr.K.Vairaperumal</p> <p>6)Mr. B.Janarthan</p> <p>7)Dr.A.Kalaiarasi</p> <p>8)Mr.C.S.Sundar Ganesh</p> <p>9)Mrs.N.Lakshmipriya</p> <p>10)Mr. K. Viswanathan</p> <p>(72)Name of Inventor :</p> <p>1)Dr.T.Vinoth Kumar</p> <p>2)Dr.N.Yogambal Jayalakshmi</p> <p>3)Mr.K.Saravanan</p> <p>4)Dr. C. Vimalraj</p> <p>5)Mr.K.Vairaperumal</p> <p>6)Mr. B.Janarthan</p> <p>7)Dr.A.Kalaiarasi</p> <p>8)Mr.C.S.Sundar Ganesh</p> <p>9)Mrs.N.Lakshmipriya</p> <p>10)Mr. K. Viswanathan</p>
---	--	--

(57) Abstract :

Abstract Battery Swapping Smart Station for Future E-Vehicle Transportation In today's world, Innovation organizations have focused on the intelligent nature of a battery swap station infrastructure with the potential to provide a standardized basis on which to deploy the large-scale fleet of hybrid successfully and electric vehicles (i. The swap battery station will calibrate its electrical-vehicle deployment subsystem by carrying out the same approach as in current petrol refuelling plants in which part or fully-charged discharged batteries are substituted or replaced by a couple of minutes. The method of battery swaps has been developed as a promising technology for the conventional EV recharging station approach since it offers individual players a wider experience. This invention idea is dedicated to integrating the battery exchange station with infrastructural, technological, charging and the main problems of the battery exchange station.

No. of Pages : 17 No. of Claims : 5

(54) Title of the invention : CRYSTAL CHEMISTRY, RIETVELD ANALYSIS, MAGNETIC AND MICROWAVE PROPERTIES OF CU-DOPED STRONTIUM HEXAFERRITES

<p>(51) International classification</p> <p>(31) Priority Document No</p> <p>(32) Priority Date</p> <p>(33) Name of priority country</p> <p>(86) International Application No Filing Date</p> <p>(87) International Publication No</p> <p>(61) Patent of Addition to Application Number Filing Date</p> <p>(62) Divisional to Application Number Filing Date</p>	<p>:C04B0035260000, C04B0035626000, C01G0049000000, H01F0001110000, G01N0022000000</p> <p>:NA</p> <p>:NA</p> <p>:NA</p> <p>:NA</p> <p>:NA</p> <p>:NA</p> <p>:NA</p> <p>:NA</p> <p>:NA</p> <p>:NA</p>	<p>(71)Name of Applicant :</p> <p>1)N. Maramu, Assistant Professor/Department of Physics, Kakatiya Institute of Technology and Science Address of Applicant :Kakatiya Institute of Technology and Science, Hasanparthy, Warangal, Telangana-506015 Telangana India</p> <p>2)M. Anil Kumar, Assistant Professor/Department of Mechanical Engineering, Kakatiya Institute of Technology and Science</p> <p>3)Dr. S. Rajyalakshmi,Assistant Professor/ Department of physics, UCST Adikavi Nannaya University</p> <p>4)Dr. Sadhana Katlakunta,Assistant Professor/Department of Physics, University College of Science</p> <p>(72)Name of Inventor :</p> <p>1)N. Maramu, Assistant Professor/Department of Physics, Kakatiya Institute of Technology and Science</p> <p>2)M. Anil Kumar, Assistant Professor/Department of Mechanical Engineering, Kakatiya Institute of Technology and Science</p> <p>3)Dr. S. Rajyalakshmi,Assistant Professor/ Department of physics, UCST Adikavi Nannaya University</p> <p>4)Dr. Sadhana Katlakunta,Assistant Professor/Department of Physics, University College of Science</p>
--	--	--

(57) Abstract :

Abstract Copper-doped M-type strontium hexaferrite particles of composition $\text{SrCu}_x\text{Fe}_{12-x}\text{O}_{19}$ ($x = 0.0$ to 1.0) through co-precipitation were synthesized. The structure of a crystal, morphology, microwave absorption, and magnetic properties of the materials were investigated in detail with Cu concentration. X-ray patterns indicated a single M-type phase for hexaferrites with $x=0.6$, while impurity phase in addition to M-type phase has been observed with $x>0.6$. The obtained results have been explained based on composition, magnetic exchange interaction, and microwave phenomena.

No. of Pages : 20 No. of Claims : 6

(12) PATENT APPLICATION PUBLICATION

(21) Application No.202141021932 A

(19) INDIA

(22) Date of filing of Application :15/05/2021

(43) Publication Date : 11/06/2021

(54) Title of the invention : A LOW COST AUTO TRACKING SOLAR PANEL CELL PHONE CHARGER

<p>(51) International classification :F24S0030000000, H04L0012400000, B61L0027000000, G08G0001133000, H04B0010110000</p> <p>(31) Priority Document No :NA</p> <p>(32) Priority Date :NA</p> <p>(33) Name of priority country :NA</p> <p>(86) International Application No :NA</p> <p>Filing Date :NA</p> <p>(87) International Publication No : NA</p> <p>(61) Patent of Addition to Application Number :NA</p> <p>Filing Date :NA</p> <p>(62) Divisional to Application Number :NA</p> <p>Filing Date :NA</p>	<p>(71)Name of Applicant :</p> <p>1)Dr. GEETHA RAMADAS Address of Applicant :PROFESSOR, DEPARTMENT OF ELECTRICAL & ELECTRONICS ENGINEERING, R.M.K. ENGINEERING COLLEGE, R.S.M. NAGAR, KAVARAIPETTAI TIRUVALLUR DISTRICT, TAMIL NADU PIN:601206 Tamil Nadu India</p> <p>2)Ms. PERARASI M</p> <p>3)Ms. M.VIMALA</p> <p>4)Mr. ALEXANDER JEEVANANTHAM</p> <p>5)Mr. K. NARESH KUMAR</p> <p>6)Ms. A. JENIFER</p> <p>7)Ms. SABARI L UMAMAHESWARI</p> <p>8)Ms. ANNIE ISABELLA L</p> <p>9)Ms. E. ELAKKIA</p> <p>10)Ms. CHANDLA ELLIS</p> <p>(72)Name of Inventor :</p> <p>1)Dr. GEETHA RAMADAS</p> <p>2)Ms. PERARASI M</p> <p>3)Ms. M.VIMALA</p> <p>4)Mr. ALEXANDER JEEVANANTHAM</p> <p>5)Mr. K. NARESH KUMAR</p> <p>6)Ms. A. JENIFER</p> <p>7)Ms. SABARI L UMAMAHESWARI</p> <p>8)Ms. ANNIE ISABELLA L</p> <p>9)Ms. E. ELAKKIA</p> <p>10)Ms. CHANDLA ELLIS</p>
--	---

(57) Abstract :

ABSTRACT A LOW COST AUTO TRACKING SOLAR PANEL CELL PHONE CHARGER Presently, the entire globe is shriveled interior into lesser weight smartphones. Despite, we migrate to different locations using a different mode of transport especially, Indians used to highly prefer public transport. During that situation, it is common for all public that there is an up-lift chance of getting battery down in our smartphones. In such time public mostly rely on the common charging points which are available in the bus depot, railway station, train and also in buses. It is evident that the smartphones which are connected to the common charging points are at a higher risk of getting hacked. We still feel that our smartphones are working well after getting power back up. Since data stealers are not injecting any mark of viruses, alternatively, they snip our precious mobile data while using electric lines to charge our phones. In general, the electric boards placed for charging are safer in Public transports such as Railway Stations or bus terminals. Though there are higher chances of some hackerTMs tactic those public places and insert some data sucking chips and maintain the circuit board as normal it is for non-identification this hacking process is commonly referred to as JUICE HACKING • common cases in the European and Western countries. To evade this problem taking place in the public localities and also to Aware the public of hacking and electricity conservation we plan this present research investigation. Thus the present invention investigation deals with designing and fabrication of solar panel in build with tracking sensors (Auto Tracking Solar Panel Cell Phone Charger) at economically less cost. Through this, we can educate or the aware public on a novel route to overcome mobile data hacking.

No. of Pages : 23 No. of Claims : 7

(12) PATENT APPLICATION PUBLICATION

(21) Application No.202141021933 A

(19) INDIA

(22) Date of filing of Application :15/05/2021

(43) Publication Date : 11/06/2021

(54) Title of the invention : VIRTUAL REALITY LEARNING AND AMUSEMENT SYSTEM BASED ON ARTIFICIAL INTELLIGENCE (AI) AND IOT

(51) International classification	:H04N0005262000, G09B0005060000, G06T0003400000, G06N0020000000, G06N0003063000	(71) Name of Applicant : 1)ADITYA ENGINEERING COLLEGE, Surampalem Address of Applicant :Aditya Nagar, ADB Road, Surampalem, East Godavari District, Andhra Pradesh, India. Pin: 533437 Andhra Pradesh India
(31) Priority Document No	:NA	(72) Name of Inventor :
(32) Priority Date	:NA	1)Dr. Sripada Rama Sree
(33) Name of priority country	:NA	2)Mrs. A. Vanathi
(86) International Application No	:NA	3)Mr. S N S V S C Ramesh
Filing Date	:NA	4)Mr. V. Andiran
(87) International Publication No	: NA	
(61) Patent of Addition to Application Number	:NA	
Filing Date	:NA	
(62) Divisional to Application Number	:NA	
Filing Date	:NA	

(57) Abstract :

ABSTRACT VIRTUAL REALITY LEARNING AND AMUSEMENT SYSTEM BASED ON ARTIFICIAL INTELLIGENCE (AI) AND IOT Aspects of present disclosure relate to system that uses virtual reality to realize various learning and amusement space themes. The system includes main server (001), clients (006), centralized control and play unit (002), communication network unit (003), an environment sensing module (004), a stereo projection unit with panoramic immersion (005). The present invention provides integration of multiple functionalities which realizes cinematic panorama mode, a memory enrichment study room mode and thereby significantly reduces software and hardware implementation costs, obtains more usable solutions at the same time, combines several features in the same mode application, and increases user immersion satisfaction and time consumption performance, improves software and hardware utilisation speed, and lowers the cost of virtual reality industrialization. Figure 1 shall be reference figure.

No. of Pages : 21 No. of Claims : 8

(12) PATENT APPLICATION PUBLICATION

(21) Application No.202141021964 A

(19) INDIA

(22) Date of filing of Application :15/05/2021

(43) Publication Date : 11/06/2021

(54) Title of the invention : AN IOT BASED NECKLACE FOR VISUALLY IMPAIRED PERSONS TO PROTECT JEWELLERY FROM KIDNAPPERS AND THIEVES

(51) International classification	:A61H0003060000, G09B0021000000, G08B0021020000, A61F0009080000, A61B0005000000	(71)Name of Applicant : 1)Mr. T. SANDEEP Address of Applicant :Assistant Professor, Department of Information Technology, Stanley College of Engineering and Technology for Women, Chapel Road, Abids, Hyderabad- 500 001, Telangana. E-Mail: tsandeeep@stanley.edu.in Telangana India 2)Dr. A. KANAKA DURGA 3)Mrs. AFREEN FATIMA MOHAMMED 4)Mrs. K. NAGAMANI 5)Mrs. T. C. SWETHA PRIYA 6)Dr. M. SATHYA 7)Dr. R. CHITHRA 8)Dr. R. DELSHI HOWSALAYA DEVI 9)N S SIVAKUMAR 10)N. NAGARAJAN
(31) Priority Document No	:NA	(72)Name of Inventor : 1)Mr. T. SANDEEP 2)Dr. A. KANAKA DURGA 3)Mrs. AFREEN FATIMA MOHAMMED 4)Mrs. K. NAGAMANI 5)Mrs. T. C. SWETHA PRIYA 6)Dr. M. SATHYA 7)Dr. R. CHITHRA 8)Dr. R. DELSHI HOWSALAYA DEVI 9)N S SIVAKUMAR 10)N. NAGARAJAN
(32) Priority Date	:NA	
(33) Name of priority country	:NA	
(86) International Application No	:NA	
Filing Date	:NA	
(87) International Publication No	: NA	
(61) Patent of Addition to Application Number	:NA	
Filing Date	:NA	
(62) Divisional to Application Number	:NA	
Filing Date	:NA	

(57) Abstract :

ABSTRACT OF THE INVENTION People who are blind have a tough time navigating the world. Walking from one location to another becomes difficult and, in some cases, risky. Visual impairment is a decrease in the ability to see to a certain degree that causes problems not fixable by usual means, such as glasses. • Blindness is described as the inability to see as a result of an injury, disease, or genetic condition. Being visually impaired or blind does not exclude people from leading normal lives. Snatching jewelry and abduction are two major challenges that visually impaired people face both indoors and outdoors. This invention is a smart necklace that protects visually impaired people, especially women, from kidnappers and jewelry thievery. This innovation includes sensors such as door sensors, ultrasonic proximity sensors for detecting human presence, and PIR sensors for detecting motion of IR light-emitting sources (typically human bodies), visual sensors capable of detecting human forms, Ambient light sensors sense the presence of light in the surrounding world. The user's voice is correctly recognized by a voice sensor. a buzzer for alarm sounding, picture capture module for capturing one or more photographs of a blind person's immediate surroundings, GSM modules to send text messages to relatives with the blind's current location via GPS sensor, ESP8266 to link and communicate via the Internet, and Raspberry Pi. Although an infrared sensor may be sufficient to detect people entering and leaving, visual sensors may be used to determine whether or not anyone is in front of the computer screen, especially in front of blind people. When a visually impaired or blind person wears an IOT based necklace and is kidnapped or has their jewelry stolen, a buzzer sends an alarm to their family or guardians based on their voice recorded by a voice sensor. Visually impaired and blind people can thus protect their lives and their belongings from kidnappers and jewel snatchers by using this invention.

No. of Pages : 12 No. of Claims : 2

(12) PATENT APPLICATION PUBLICATION

(21) Application No.202141021974 A

(19) INDIA

(22) Date of filing of Application :16/05/2021

(43) Publication Date : 11/06/2021

(54) Title of the invention : A NOVEL WATERMARKING TECHNIQUES FOR 3D MESH OBJECTS

(51) International classification	:G06T0001000000, H04N0001320000, H04N0021835800, H04W0012100000, H04L0029060000	(71) Name of Applicant : 1)Dr. Shubhangi Digamber Chikte Address of Applicant :Professor, Department of computer science and Engineering, Visvesvaraya Technological university(VTU), center for PG studies, KALABURAGI-585105, Karnataka, India. E-Mail: shubhangidc@vtu.ac.in +91-9448716838 Karnataka India
(31) Priority Document No	:NA	2)Manikamma Malipatil
(32) Priority Date	:NA	(72) Name of Inventor :
(33) Name of priority country	:NA	1)Dr. Shubhangi Digamber Chikte
(86) International Application No	:PCT//	2)Manikamma Malipatil
Filing Date	:01/01/1900	
(87) International Publication No	: NA	
(61) Patent of Addition to Application Number	:NA	
Filing Date	:NA	
(62) Divisional to Application Number	:NA	
Filing Date	:NA	

(57) Abstract :

A novel watermarking techniques for 3D mesh objects Abstract Our Invention novel watermarking techniques for 3D mesh objects is a watermark from an encoded image opens the possibility of various novel applications and also a Several such applications are detailed. The invention is to an employs a reversible watermark in conjunction with a second (robust) watermark and the arrangement, the payload of the reversible watermark conveys data about the robust watermark (e.g., encoding parameters, or an error signal), permitting removal of the robust watermark from an uncorrupted encoded image. The invented technology is also a encoded image can be fully restored to its pristine, uuencoded state even if several different watermarks have been applied and the invention relates to a method of integrity protection of a three-dimensional model, which is characterized in that the method is divided into two steps of embedding watermark and verifying watermark: (1) a vertex for embedding watermark is chosen, and the watermark vertex and the neighboring vertex is led to distribute the whole module as far as possible. (2) a coordinate X1 of each vertex is adjusted, and whether the vertex is a watermark vertex is identified. (3) for each watermark vertex, wi is embedded into x2, and h(wi) is embedded to x3.

No. of Pages : 15 No. of Claims : 7

(12) PATENT APPLICATION PUBLICATION

(21) Application No.202141021977 A

(19) INDIA

(22) Date of filing of Application :16/05/2021

(43) Publication Date : 11/06/2021

(54) Title of the invention : A SYSTEM FOR MONITORING IMPACT OF SACRED CHANTS ON PLANTS AND TREES THROUGH EMW RADIATIONS

(51) International classification	:H04L0012240000, H04B0017210000, G06F0016600000, G06F0016638000, G10H0001000000	(71)Name of Applicant : 1)Dr.S.Thenappan Address of Applicant :Professor of ECE, Department of ECE, KNS Institute of Technology, Bengaluru, Karnataka, India. Pin Code:560064 Karnataka India 2)Mr.N.Manoj Kumar 3)Dr.S.Anantha Padmanabhan 4)Dr.K.Senthil Babu 5)Dr. Pradeep Kumar N.S 6)Dr.S.Mani Naidu 7)Mr.Sukumar B.S 8)Dr.R.Bhargava Rama Gowd
(31) Priority Document No	:NA	(72)Name of Inventor : 1)Dr.S.Thenappan 2)Mr.N.Manoj Kumar 3)Dr.S.Anantha Padmanabhan 4)Dr.K.Senthil Babu 5)Dr. Pradeep Kumar N.S 6)Dr.S.Mani Naidu 7)Mr.Sukumar B.S 8)Dr.R.Bhargava Rama Gowd
(32) Priority Date	:NA	
(33) Name of priority country	:NA	
(86) International Application No	:NA	
Filing Date	:NA	
(87) International Publication No	: NA	
(61) Patent of Addition to Application Number	:NA	
Filing Date	:NA	
(62) Divisional to Application Number	:NA	
Filing Date	:NA	

(57) Abstract :

ABSTRACT A SYSTEM FOR MONITORING IMPACT OF SACRED CHANTS ON PLANTS AND TREES THROUGH EMW RADIATIONS [031] This invention provides a system for monitoring impact of sacred chants on plants and trees through Electromagnetic waves (EMW) radiations. The system includes, but not limited to, a plurality of audio devices for producing sacred chants such as Slokas, Mantras, Duas and Music in the form of Audio; a converting unit designed to convert audios (Mantras, Slokas, Duas and Music) into Electromagnetic waves (EMW), by using an antenna; a processing unit to receive input from the audio devices and antenna, which is further processed and analysed with different antenna parameters, accordingly. Further, the audio is simulated with a user interface or software to determine different antenna parameters provided on a computing device. In addition, the user interface is configured to view and further analysing different antenna parameters. Accompanying drawing [FIGS. 1-4]

No. of Pages : 18 No. of Claims : 8

(12) PATENT APPLICATION PUBLICATION

(21) Application No.202141021986 A

(19) INDIA

(22) Date of filing of Application :17/05/2021

(43) Publication Date : 11/06/2021

(54) Title of the invention : HYBRID MECHANICAL JUICER MIXER GRINDER

(51) International classification	:A47J0019020000, A47J0019060000, G05D0001000000, A47J0043070000, F16K0031050000	(71) Name of Applicant : 1)Dr. Dareddy Ramana Reddy Address of Applicant :Department of Mechanical Engineering, St. Martin's Engineering College, Sy. No.98, Dulapally Road, Dhulapally, Near Kompally, Secunderabad, Telangana-500100, India. Telangana India
(31) Priority Document No	:NA	(72) Name of Inventor :
(32) Priority Date	:NA	1)Dr. Dareddy Ramana Reddy
(33) Name of priority country	:NA	
(86) International Application No	:NA	
Filing Date	:NA	
(87) International Publication No	: NA	
(61) Patent of Addition to Application Number	:NA	
Filing Date	:NA	
(62) Divisional to Application Number	:NA	
Filing Date	:NA	

(57) Abstract :

ABSTRACT: Title: Hybrid Mechanical Juicer Mixer Grinder The present disclosure proposes a Hybrid Juicer Mixer Grinder that can be utilized either in manual mode or in automatic mode based on necessity. The proposed hybrid juicer is integrated with power drive, manual drive, a spindle and a juicer that saves electricity and aids the user to make juices even when power supply is not present. Further the hybrid juicer is configured with a lever that enables switching between automatic mood and manual mode with ease. The hybrid juicer mixer grinder is equally useful for rural as well as urban areas.

No. of Pages : 9 No. of Claims : 10

(12) PATENT APPLICATION PUBLICATION

(21) Application No.202141021987 A

(19) INDIA

(22) Date of filing of Application :17/05/2021

(43) Publication Date : 11/06/2021

(54) Title of the invention : HIGH SPEED OPPOSITE PISTON ENGINE WITH DOUBLE CRANKS

(51) International classification :F02B0053000000,
F02B0075320000,
F02B0075280000,
F02B0053040000,
F02B0071000000
(31) Priority Document No :NA
(32) Priority Date :NA
(33) Name of priority country :NA
(86) International Application No :NA
Filing Date :NA
(87) International Publication No : NA
(61) Patent of Addition to Application Number :NA
Filing Date :NA
(62) Divisional to Application Number :NA
Filing Date :NA

(71)**Name of Applicant :**
1)Dr. Dareddy Ramana Reddy
Address of Applicant :Department of Mechanical
Engineering, St. Martin's Engineering College, Sy. No.98,
Dulapally Road, Dhulapally, Near Kompally, Secunderabad,
Telangana-500100, India. Telangana India
(72)**Name of Inventor :**
1)Dr. Dareddy Ramana Reddy

(57) Abstract :

ABSTRACT: Title: High speed opposite piston engine with double cranks The present disclosure proposes a high speed opposite piston engine with double cranks. The proposed engine utilizes planetary gear train to drive the flywheel at high speed which reduces size of flywheels. The proposed engine is an economical alternative to the conventional multi cylinder engines of the same power capacity. The opposite piston engine provides better brake thermal efficiency than conventional multi cylinder engine of the same capacity and hence provides better fuel economy. Further, the proposed engine reduces idle speed thereby reducing the frictional power loss during idle speed.

No. of Pages : 17 No. of Claims : 5

(12) PATENT APPLICATION PUBLICATION

(21) Application No.202141021988 A

(19) INDIA

(22) Date of filing of Application :17/05/2021

(43) Publication Date : 11/06/2021

(54) Title of the invention : VARIABLE VOLUME ROTARY APPARATUS

(51) International classification :F02B0053000000,
F04C0002260000,
F01C0001200000,
F02B0075320000,
F01C0001000000
(31) Priority Document No :NA
(32) Priority Date :NA
(33) Name of priority country :NA
(86) International Application No :NA
Filing Date :NA
(87) International Publication No : NA
(61) Patent of Addition to Application Number :NA
Filing Date :NA
(62) Divisional to Application Number :NA
Filing Date :NA

(71)**Name of Applicant :**
1)Dr. Dareddy Ramana Reddy
Address of Applicant :Department of Mechanical
Engineering, St. Martin's Engineering College, Sy. No.98,
Dulapally Road, Dhulapally, Near Kompally, Secunderabad,
Telangana-500100, India. Telangana India
(72)**Name of Inventor :**
1)Dr. Dareddy Ramana Reddy

(57) Abstract :

ABSTRACT: Title: Variable Volume Rotary Apparatus The present disclosure proposes a variable volume rotary apparatus that has two rotary discs, and a rotary eye placed in the central hole of cap. The variable volume apparatus aids to combine the better performance characteristics of reciprocating system with those of centrifugal system. The proposed apparatus functions either as a pump or a compressor or a turbine or a rotary internal combustion engine. The proposed apparatus eliminates the need for a clutch when placed in the axle of wheel between the two forks. The apparatus aids to conserve most of the kinetic energy for a short while which is generally lost generally during frequent break applications.

No. of Pages : 25 No. of Claims : 2

(12) PATENT APPLICATION PUBLICATION

(21) Application No.202141021989 A

(19) INDIA

(22) Date of filing of Application :17/05/2021

(43) Publication Date : 11/06/2021

(54) Title of the invention : VEHICLE WITH MULTI ENGINE ASSEMBLY

(51) International classification	:F02B0073000000, B60K0005080000, B60W0030180000, B62D0021150000, F16H0001220000	(71) Name of Applicant : 1)Dr. Dareddy Ramana Reddy Address of Applicant :Department of Mechanical Engineering, St. Martin's Engineering College, Sy. No.98, Dulapally Road, Dhulapally, Near Kompally, Secunderabad, Telangana-500100, India. Telangana India
(31) Priority Document No	:NA	(72) Name of Inventor :
(32) Priority Date	:NA	1)Dr. Dareddy Ramana Reddy
(33) Name of priority country	:NA	
(86) International Application No	:NA	
Filing Date	:NA	
(87) International Publication No	: NA	
(61) Patent of Addition to Application Number	:NA	
Filing Date	:NA	
(62) Divisional to Application Number	:NA	
Filing Date	:NA	

(57) Abstract :

ABSTRACT: Title: Vehicle with Multi Engine Assembly The present disclosure proposes an vehicle with multi engine assembly. The is configured with two engines mounted side by side on a frame, and output shafts are coupled to each other. The present invention makes the vehicle cheaper than other hybrid vehicles with same improvement in fuel efficiency. The proposed multi-engine assembly concept provides standby when one engine fails due to any reason. The proposed vehicle provides facility to run the vehicle engine at high load in all driving conditions thereby the increasing the fuel efficiency. Further the vehicle aids to reduce frictional losses since efficiency of engine is high at high loads.

No. of Pages : 13 No. of Claims : 7

(12) PATENT APPLICATION PUBLICATION

(21) Application No.202141021990 A

(19) INDIA

(22) Date of filing of Application :17/05/2021

(43) Publication Date : 11/06/2021

(54) Title of the invention : DESIGN AND ANALYSIS OF OCTAHEDRON DIELECTRIC RESONATOR ANTENNA FOR S-BAND WIRELESS APPLICATIONS

(51) International classification	:H01Q0009040000, C04B0035622000, H01Q0019060000, H01Q0015140000, H01Q0015080000	(71)Name of Applicant : 1)Gundre Mohith Reddy Address of Applicant :School of ECE, REVA University Rukmini Knowledge Park, Kattigenahalli, Yelahanka, Bengaluru, Karnataka 560064 Karnataka India 2)Bellam Sai Deepak 3)Kullayappa Manjunath Gari Shyamprasad 4)Muppala Yeswanth Varma 5)Sowmiya Bharani 6)Subhash B K
(31) Priority Document No	:NA	(72)Name of Inventor :
(32) Priority Date	:NA	1)Gundre Mohith Reddy
(33) Name of priority country	:NA	2)Bellam Sai Deepak
(86) International Application No	:NA	3)Kullayappa Manjunath Gari Shyamprasad
Filing Date	:NA	4)Muppala Yeswanth Varma
(87) International Publication No	: NA	5)Sowmiya Bharani
(61) Patent of Addition to Application	:NA	6)Subhash B K
Number	:NA	
Filing Date	:NA	
(62) Divisional to Application Number	:NA	
Filing Date	:NA	

(57) Abstract :

The proposed Octahedron design measures a Wide Band incorporated Dielectric Resonator Antenna for S band application. The proposed design is a 3-Dimensional Octahedron shaped Dielectric Resonating Antenna. DRA is energized by utilizing molded gap. The recreation measure is finished with the assistance of CST Studio suite software. The transmitting structure is works for wideband operation between 2.1GHz to 4.1GHz. The transmission bandwidth is 2GHz and 2.7dB, 3.4dB and 4.6dB of gain observed by the proposed antenna at resonances 2.3GHz, 2.9GHz and 3.7GHz respectively and the Impedance value of the design is 49.8Ohms. The proposed Octahedron Dielectric Resonating radiator has good gain, efficiency, and stable radiation pattern and appropriate for S band application.

No. of Pages : 8 No. of Claims : 2

(12) PATENT APPLICATION PUBLICATION

(21) Application No.202141022036 A

(19) INDIA

(22) Date of filing of Application :17/05/2021

(43) Publication Date : 11/06/2021

(54) Title of the invention : DEVELOPMENT OF A SCREENING TOOL FOR SLEEP APNEA FOR EXPERTS IN CLINICAL SETUPS

(51) International classification	:A61B0005000000, A61F0005560000, A61B0005145500, A61B0007000000, A61B0005080000	(71)Name of Applicant : 1)Dr.Poornima G Patil Address of Applicant :Designation: Assistant Professor Dept of CSE, Visvesvaraya Technological University Belagavi Karnataka 590018 India poornima_g_patil@yahoo.com 9448866425 Karnataka India 2)Dr. Jyoti Bali 3)Gireesha H M 4)Prabhavathi C. Nissimagoudar 5)Dr. S. R. Nirmala 6)Dr.Suvarna G Kanakaraddi 7)Rajeshri Rahul Itkarkar 8)Dr. Karuna C. Gull 9)Prof. Jaya Pattanshetti 10)Dr. Piyush Kumar Pareek
(31) Priority Document No	:NA	(72)Name of Inventor : 1)Dr.Poornima G Patil 2)Dr. Jyoti Bali 3)Gireesha H M 4)Prabhavathi C. Nissimagoudar 5)Dr. S. R. Nirmala 6)Dr.Suvarna G Kanakaraddi 7)Rajeshri Rahul Itkarkar 8)Dr. Karuna C. Gull 9)Prof. Jaya Pattanshetti 10)Dr. Piyush Kumar Pareek
(32) Priority Date	:NA	
(33) Name of priority country	:NA	
(86) International Application No	:NA	
Filing Date	:NA	
(87) International Publication No	: NA	
(61) Patent of Addition to Application	:NA	
Number	:NA	
Filing Date	:NA	
(62) Divisional to Application Number	:NA	
Filing Date	:NA	

(57) Abstract :

TITLE OF INVENTION: Development of a Screening tool for Sleep Apnea for experts in clinical setups FIELD OF INVENTION: COMPUTER SCIENCE ABSTRACT Sleep apnea is a type of breathing disorder caused by interruptions in breathing or shallow breathing during night sleep. The disorder can occur in three different forms namely, Obstructive Sleep apnea (OSA), Central Sleep apnea (CSA) and Mixed Sleep apnea (MSA) among which OSA is the most prevalent. In all these three forms of sleep apnea, the interrupted breathing activity leads to the problem of oxygen deficiency leading to the development of chronic cardiac related ailments. Hence an earlier detection of sleep apnea can save patient from life risk. The Invention discloses a low-power, highperformance algorithm for sleep apnea detection based on ECG signal.

No. of Pages : 16 No. of Claims : 1

(54) Title of the invention : SMART AGRICULTURE CHANGEOVER BOX

<p>(51) International classification</p> <p>(31) Priority Document No</p> <p>(32) Priority Date</p> <p>(33) Name of priority country</p> <p>(86) International Application No Filing Date</p> <p>(87) International Publication No</p> <p>(61) Patent of Addition to Application Number Filing Date</p> <p>(62) Divisional to Application Number Filing Date</p>	<p>:G06Q0050020000, H02P0005460000, A01G0025160000, A01M0009000000, H02K0017300000</p> <p>:NA</p> <p>:NA</p> <p>:NA</p> <p>:NA</p> <p>:NA</p> <p>:NA</p> <p>:NA</p> <p>:NA</p> <p>:NA</p> <p>:NA</p>	<p>(71)Name of Applicant :</p> <p>1)BALASUBRAMANIYAM S Address of Applicant :UG Student, Department of EEE, Bannari Amman Institute of Technology, Sathyamangalam, Erode 638401 Tamil Nadu India</p> <p>2)SANGEETHKUMAR C</p> <p>3)SANJAY P</p> <p>4)PATTILINGAM V</p> <p>5)NAVEENKUMAR S</p> <p>6)NAVEEN N</p> <p>7)KAMATCHI KANNAN VIJAYARANGAN</p> <p>8)MAHESWARI KARATTADIPALAYAM THANGAVEL</p> <p>9)VEERAKUMAR SUBRAMANIAN</p> <p>(72)Name of Inventor :</p> <p>1)BALASUBRAMANIYAM S</p> <p>2)SANGEETHKUMAR C</p> <p>3)SANJAY P</p> <p>4)PATTILINGAM V</p> <p>5)NAVEENKUMAR S</p> <p>6)NAVEEN N</p> <p>7)KAMATCHI KANNAN VIJAYARANGAN</p> <p>8)MAHESWARI KARATTADIPALAYAM THANGAVEL</p> <p>9)VEERAKUMAR SUBRAMANIAN</p>
--	--	--

(57) Abstract :

India is a land of agriculture in which Indian farmers plays a vital role. Nowadays, farmers utilize the changeover box manually to control the On/Off of their inductions motor which is located at agricultural field. The farmers can run one induction motor at a time probably if they are single service provider. The manually operated present changeover box has some drawbacks such as it needs the farmer/user to be physically present to turn on/off their induction motors and also has to continuously monitor the inductions motor which helps to pump water to the agricultural fields. The farmer needs to physically change the lever of the changeover box to switch the supply to operate more than one induction motors, this consumes much time for the farmers and also it is difficult for the farmers who are old. Hence, the proposed system remotely controls the lever of the changeover box using the farmer/user smartphone from anywhere through internet. The proposed system involves a DC motor to control the switching action of the changeover box which is connected through NodeMCU ESP8266 and motor driver. This setup helps the farmer to turn on/off the induction motors remotely, to determine which induction motor need to run and also the condition of fuse etc from anywhere using a mobile app over internet connection.

No. of Pages : 10 No. of Claims : 8

(12) PATENT APPLICATION PUBLICATION

(21) Application No.202141022112 A

(19) INDIA

(22) Date of filing of Application :17/05/2021

(43) Publication Date : 11/06/2021

(54) Title of the invention : SYSTEM AND METHOD FOR CONNECTING A SERVICE PROVIDER AND A SERVICE SEEKER FOR A SERVICE

(51) International classification	:G06Q0010080000, G08G0001000000, H04L0029080000, G06Q0010020000, G06F0009500000	(71) Name of Applicant : 1)ONTIPALLI VENKATA HARIKA Address of Applicant :FLAT NO: 202, DOOR NO: 16-1-4, PRANAV ENCLAVE, SRIRAMNAGAR, RAJAMAHENDRAVARAM, 533105, ANDHRA PRADESH, INDIA Andhra Pradesh India
(31) Priority Document No	:NA	(72) Name of Inventor :
(32) Priority Date	:NA	1)ONTIPALLI VENKATA HARIKA
(33) Name of priority country	:NA	
(86) International Application No	:NA	
Filing Date	:NA	
(87) International Publication No	: NA	
(61) Patent of Addition to Application Number	:NA	
Filing Date	:NA	
(62) Divisional to Application Number	:NA	
Filing Date	:NA	

(57) Abstract :

A system (100) for connecting a service provider and a service seeker is disclosed. A service request receiving module (110) receives one or more service delivery requests from the service seeker. A service provider searching module (120) fetches prestored registration information associated with one or more service providers available in proximity to the first geographical location from a service provider repository, searches the one or more service providers corresponding to the service seeker. A service provider selection module (130) selects a service provider from the one or more service providers. A request finalization module (140) determines a category of an item from the one or more service delivery requests, recommends a type of packaging corresponding to the category of the item assigned for the delivery. A route optimization module (140) optimizes a delivery route for the service provider for accomplishment of the service delivery request associated with the item. FIG. 1

No. of Pages : 28 No. of Claims : 10

(54) Title of the invention : SOILLESS AGRICULTURAL MONITORING AND CONTROLLING BASED ON IOT

(51) International classification	:G06Q0050020000, A01G0025160000, G01D0021020000, H04L0029080000, A01B0079000000	(71)Name of Applicant : 1)Dr.M. Sudha Address of Applicant :Assistant Professor Department of Electronic and Communication Engineering Srinivasa Ramanujan Centre SASTRA Deemed to be University Kumbakonam Tamil Nadu India
(31) Priority Document No	:NA	2)Dr.A.Meenakshi
(32) Priority Date	:NA	3)Anooja Ali
(33) Name of priority country	:NA	4)A.Ajil
(86) International Application No	:NA	5)Dr. L.Arun Raj
Filing Date	:NA	6)Dr V P Gladis Pushparathi
(87) International Publication No	: NA	(72)Name of Inventor :
(61) Patent of Addition to Application Number	:NA	1)Dr.M. Sudha
Filing Date	:NA	2)Dr.A.Meenakshi
(62) Divisional to Application Number	:NA	3)Anooja Ali
Filing Date	:NA	4)A.Ajil
		5)Dr. L.Arun Raj
		6)Dr V P Gladis Pushparathi

(57) Abstract :

IoT-based smart farming makes it possible for farmers and farmers to reduce waste and increase productivity ranging from quantities of fertilizer to the number of traveling operations by agricultural vehicles and to efficiently utilize resources such as water, power, etc. IoT intelligent farmer solutions are a system designed with sensors (light, humidity, temperature, soil humidity, crop health, etc.) and the automation of irrigation systems for monitoring the crop field. The prediction of crop yield is extremely difficult due to its reliance on many factors including crop genotype, environmental conditions, management techniques and their interfaces. The information collected by farm sensors is used to forecast the production rate of the crop artificial network. This information contains parameters such as soil, temperature, pressure, precipitation and moisture. Precise yield prediction requires a basic overview of the key relationship between yield and those interacting factors and requires both detailed datasets and efficient algorithms to demonstrate that relationship. A machine learning environment based on environmental data is proposed using IoT for crop yield prediction. To collect such data, a wireless sensor network is set up and retrospectively uploaded to the cloud. We also rendered feature selection based on a trained machine learning model, which enhanced prediction accuracy successfully. Farmers can obtain precise soil information either via the dashboard or via a custom mobile app. Our calculative results showed that the model surpassed other common machine learning approaches significantly.

No. of Pages : 13 No. of Claims : 6

(12) PATENT APPLICATION PUBLICATION

(21) Application No.202141022163 A

(19) INDIA

(22) Date of filing of Application :17/05/2021

(43) Publication Date : 11/06/2021

(54) Title of the invention : A POWER QUALITY AND DEMAND SIDE MANAGEMENT SYSTEM FOR A SMART GRID USING MACHINE LEARNING FOR PROVIDING EFFICIENT RESOURCE UTILIZATION AND THE METHOD THEREOF

(51) International classification	:G06Q0050060000, H02J0013000000, G06Q0010060000, G06N0020000000, G06Q0010040000	(71) Name of Applicant : 1)Dr. Mallikarjunaswamy S Address of Applicant :JSS Academy of Technical Education, JSSATE-B, Campus, Dr.Vishnuvardhan Road, Srinivasapura-Post, Bengaluru 560 060, Karnataka, India Karnataka India 2)Dr. Siddesh G K
(31) Priority Document No	:NA	(72) Name of Inventor : 1)S, Mallikarjunaswamy
(32) Priority Date	:NA	2)G K Siddesh
(33) Name of priority country	:NA	3)N Sharmila
(86) International Application No	:NA	4)M Komala
Filing Date	:NA	5)H N, Mahendra
(87) International Publication No	: NA	6)D, Prakyath
(61) Patent of Addition to Application Number	:NA	7)D, Mahesh Kumar
Filing Date	:NA	8)K, Sathisha Shet
(62) Divisional to Application Number	:NA	9)N Mahesh Kumar
Filing Date	:NA	10)S Pooja
		11)M L, Umashankar
		12)V, Rekha
		13)K, Shashiraj

(57) Abstract :

Abstract: Title: A Power quality and demand side management System for a smart grid Using Machine Learning for providing efficient resource utilization and the method thereof Electricity plays a crucial role in different sectors of the nation including national security, economy, agriculture and healthcare. The design of the power system has been revolutionized by the incorporation of communication technology. This makes the grid smart. Several issues have been addressed in order to make the utility grid smart. In this work, an enhanced algorithm for Power Quality and demand side management (PQDSM) has been proposed using the machine learning for a smart grid. The proposed algorithm ensures sufficient usage of the energy depending on the priorities allocated in the grid. To effectively control the intrusions into the smart grid, a reconfigurable model has been proposed. The recent agent helps in identifying the dishonest entities by making use of the machine learning classifier. The energy utilization can be made optimal by having the accurate information about the energy using the advanced Energy Management along with the interface controlling agents. The proposed scheme has been tested using an efficient simulation tool. From the evaluation, the results revealed that the proposed power quality and demand side management scheme is less vulnerable to any dishonest entity intrusion and optimizes the power utilization in the smart grid. Figure 1

No. of Pages : 27 No. of Claims : 10

(12) PATENT APPLICATION PUBLICATION

(21) Application No.202141022167 A

(19) INDIA

(22) Date of filing of Application :18/05/2021

(43) Publication Date : 11/06/2021

(54) Title of the invention : A NOVEL APPROACH TO IDENTIFY THE FACIAL PARTS USING LOCAL BINARY PATTERN AND COMBINED LVQ CLASSIFIERS

(51) International classification	:G06K0009000000, G06K0009620000, G06K0009460000, G06K0009660000, G06N0020100000	(71)Name of Applicant : 1)Adulapuram Pradeep, Asst professor/ Department of CSE, TKR College of Engineering and Technology Address of Applicant :TKR College of Engineering and Technology, Saroor Nagar,Rangareddy, Hyderabad, Telangana-500097 Telangana India 2)G. Keerthi, Research Scholar /Department of CSE, SRM Institute of Science and Technology 3)Bathini. Sangeetha, Assistant Professor(c) / Department of CSE, JNTUH College of Engineering Sulthanpur 4)Er. Sandeep Ravikanti, Asst professor/ Department of CSE, Methodist College of Engineering & Technology 5)Deva Rajashekar, Asst professor/ Department of CSE, Methodist College of Engineering & Technology 6)Lingala Thirupathi, Research Scholar/ Department of CSE, Gitam Institute of Technology, Gitam (Deemed to be University).
(31) Priority Document No	:NA	(72)Name of Inventor : 1)Adulapuram Pradeep, Asst professor/ Department of CSE, TKR College of Engineering and Technology 2)G. Keerthi, Research Scholar /Department of CSE, SRM Institute of Science and Technology 3)Bathini. Sangeetha, Assistant Professor(c) / Department of CSE, JNTUH College of Engineering Sulthanpur 4)Er. Sandeep Ravikanti, Asst professor/ Department of CSE, Methodist College of Engineering & Technology 5)Deva Rajashekar, Asst professor/ Department of CSE, Methodist College of Engineering & Technology 6)Lingala Thirupathi, Research Scholar/ Department of CSE, Gitam Institute of Technology, Gitam (Deemed to be University).
(32) Priority Date	:NA	
(33) Name of priority country	:NA	
(86) International Application No	:NA	
Filing Date	:NA	
(87) International Publication No	: NA	
(61) Patent of Addition to Application Number	:NA	
Filing Date	:NA	
(62) Divisional to Application Number	:NA	
Filing Date	:NA	

(57) Abstract :

Abstract Security is place a major role in current industry. Authentication of the person is very important in the real world to access the information. One of the best methods is Face recognition which is used for human identification and verification. This biometric method has a unique feature from recognizing one person to another in security field. We propose an algorithm for Face recognition and classification called on Local Binary Pattern (LBP). In static approach, LBP consists of histogram properties for feature extraction. Combined Learning Vector Quantization (LVQ) Classifier is used as Neural Network approach in order to recognize the image form database. The input image is first divided into small regions like eyes, nose, and mouth from which Local Binary Patterns (LBP) histograms are extracted and concatenated into a single feature vector. This input vector is calculated using Euclidian distance to generate the output.

No. of Pages : 14 No. of Claims : 3

(12) PATENT APPLICATION PUBLICATION

(21) Application No.202141022168 A

(19) INDIA

(22) Date of filing of Application :18/05/2021

(43) Publication Date : 11/06/2021

(54) Title of the invention : VIGNA. SP BASED BIOCOMPOSITES AND PROCESS FOR MANUFACTURING THEREOF

(51) International classification	:C08L0023020000, C08L0023100000, C08J0005040000, D21H0011080000, C08L0099000000	(71) Name of Applicant : 1)Yenduva Shanti Address of Applicant :Research Scholar, Department of Mechanical Engineering, School of Technology, GITAM (Deemed to be University), Hyderabad Telangana India
(31) Priority Document No	:NA	2)Ambadipudi Satyadevi
(32) Priority Date	:NA	(72) Name of Inventor :
(33) Name of priority country	:NA	1)Yenduva Shanti
(86) International Application No	:NA	2)Ambadipudi Satyadevi
Filing Date	:NA	
(87) International Publication No	: NA	
(61) Patent of Addition to Application Number:	NA	
Filing Date	:NA	
(62) Divisional to Application Number	:NA	
Filing Date	:NA	

(57) Abstract :

7. ABSTRACT The present invention relates to the bio-composite material and its production method are described. The bio-composite exhibits physical stiffness, strength and toughness comparable to conventional natural fibers. filler material such as Vigna mungo peel powder (VM) that comes from agricultural waste. The material is environmentally friendly and results in light load-bearing capacity. The fabrication of mechanical, and thermomechanical characterization of 10 and 15wt% VM filled glass fiber polymer composites in the present invention. Mechanical strength was determined by tensile, flexural, impact, and hardness measurements according to ASTM standards. Thermomechanical characterization was done by determining damping parameters such as storage modulus, loss modulus, tan delta and the glass transition temperature by the DMA test. The present invention demonstrated that 10 wt% filled composites got excellent mechanical and thermomechanical properties with less mechanical loss, and has significant practical applications. Fig. 1

No. of Pages : 25 No. of Claims : 10

(12) PATENT APPLICATION PUBLICATION

(21) Application No.202141022170 A

(19) INDIA

(22) Date of filing of Application :18/05/2021

(43) Publication Date : 11/06/2021

(54) Title of the invention : METHOD, SYSTEM AND DEVICE FOR INTRUSION DETECTION

(51) International classification	:G08B0013196000, G08B0025080000, G06K0009000000, G08B0013190000, G08B0013240000	(71) Name of Applicant : 1)Dr. D Jaya Kumari Address of Applicant :Dept. of CSE, Sri Vasavi Engineering College (A), Pedatadepalli, Tadepalligudem, Andhra Pradesh - 534101, India Andhra Pradesh India
(31) Priority Document No	:NA	2)Dr. Rupa Chiramdasu
(32) Priority Date	:NA	(72) Name of Inventor :
(33) Name of priority country	:NA	1)Dr. D Jaya Kumari
(86) International Application No	:NA	2)Dr. Rupa Chiramdasu
Filing Date	:NA	
(87) International Publication No	: NA	
(61) Patent of Addition to Application Number	:NA	
Filing Date	:NA	
(62) Divisional to Application Number	:NA	
Filing Date	:NA	

(57) Abstract :

METHOD, SYSTEM AND DEVICE FOR INTRUSION DETECTION ABSTRACT In one aspect, an intrusion detection system for detecting an intruder comprising, an intrusion detection device, a camera, an external server and a database. The intrusion detection device is capable of monitoring the temperature and detecting a change in temperature values in the vicinity at a specific location caused by the intruder, through one or more sensing elements. The camera is capable of capturing a facial image of the intruder, when the increase in temperature value is found compared to the threshold value. The external server is capable of receiving and processing critical information, wherein the critical information is the change in temperature values and captured image and the database, is capable of storing a critical information and triggering an alert to an owner over a GSM and an email. [FIG. 1]

No. of Pages : 17 No. of Claims : 10

(12) PATENT APPLICATION PUBLICATION

(21) Application No.202141022214 A

(19) INDIA

(22) Date of filing of Application :18/05/2021

(43) Publication Date : 11/06/2021

(54) Title of the invention : MACHINE LEARNING BASED EEG SIGNAL PROCESSING FOR SMART PATIENT MONITORING SYSTEM

<p>(51) International classification</p> <p>(31) Priority Document No</p> <p>(32) Priority Date</p> <p>(33) Name of priority country</p> <p>(86) International Application No Filing Date</p> <p>(87) International Publication No</p> <p>(61) Patent of Addition to Application Number Filing Date</p> <p>(62) Divisional to Application Number Filing Date</p>	<p>:A61B0005000000, A61B0005047600, A61B0005047800, A61B0005040000, A61B0005048000</p> <p>:NA</p> <p>:NA</p> <p>:NA</p> <p>:NA</p> <p>:NA</p> <p>:NA</p> <p>:NA</p> <p>:NA</p> <p>:NA</p> <p>:NA</p> <p>:NA</p>	<p>(71)Name of Applicant :</p> <p>1)Dr. Ganesh Kumar R,CHRIST (Deemed to be University) Address of Applicant :Associate Professor Department of Computer Science and Engineering, School of Engineering and Technology, CHRIST (Deemed to be University) - Bangalore Karnataka India Karnataka India</p> <p>2)Dr. Madhavi Mallam,PES Institute of Technology and Management</p> <p>3)Saravanakumar Pichumani,Bannari Amman Institute of Technology</p> <p>4)Srinivas Nagineni, KG Reddy college of engineering & Technology (JNTU Hyderabad)</p> <p>5)Madhurika Budaraju,Keshav Memorial Institute of Technology</p> <p>6)Ramashis Banerjee,National Institute of Technology Silchar</p> <p>7)Dr.S.K. Manju bargavi,Jain (Deemed-to-be) University</p> <p>8)Dr. Suresh L,RNS Institute of Technology</p> <p>9)Rajesh kumar S,Cambridge Institute of Technology</p> <p>10)Mahesh Kumar A S,PES College of Engineering</p> <p>11)Kakirala Durga Bhavani,SRMIST</p> <p>12)Karthikayani.K,SRM Institute of Science and Technology</p> <p>(72)Name of Inventor :</p> <p>1)Dr. Ganesh Kumar R,CHRIST (Deemed to be University)</p> <p>2)Dr. Madhavi Mallam,PES Institute of Technology and Management</p> <p>3)Saravanakumar Pichumani,Bannari Amman Institute of Technology</p> <p>4)Srinivas Nagineni, KG Reddy college of engineering & Technology (JNTU Hyderabad)</p> <p>5)Madhurika Budaraju,Keshav Memorial Institute of Technology</p> <p>6)Ramashis Banerjee,National Institute of Technology Silchar</p> <p>7)Dr.S.K. Manju bargavi,Jain (Deemed-to-be) University</p> <p>8)Dr. Suresh L,RNS Institute of Technology</p> <p>9)Rajesh kumar S,Cambridge Institute of Technology</p> <p>10)Mahesh Kumar A S,PES College of Engineering</p> <p>11)Kakirala Durga Bhavani,SRMIST</p> <p>12)Karthikayani.K,SRM Institute of Science and Technology</p>
--	---	---

(57) Abstract :

In the current pandemic situation, patients with critical diseases are lacking immediate care which would reduce the mortality rate. This invention focuses on continuous monitoring of patientTMs EEG signals for occurrence of any seizures in brain signals. This system is designed using machine learning algorithm for resource optimization thereby implemented using VLSI technology. The proposed algorithm provides competitive performance as it requires EEG signals only from front and frontal temporal lobes instead of signals from standard full EEG system. Seizure detection is accurate just by easily mountable headsets of dry electrode without the need of painful through- hair electrodes which is highly uncomfortable and uses adhesive material. Compact VLSI implementation is uploaded on low power FPGA Actel Igloo AGL250 that consumes 110 Watts of dynamic power and required 1237 logical elements, operating at a detection latency of 10.2 seconds provides specificity of 80.2% and sensitivity of detection as 92.6%.

No. of Pages : 11 No. of Claims : 6

(12) PATENT APPLICATION PUBLICATION

(21) Application No.202141022278 A

(19) INDIA

(22) Date of filing of Application :18/05/2021

(43) Publication Date : 11/06/2021

(54) Title of the invention : A SYSTEM, APPARATUS, AND METHOD FOR HARNESSING ENERGY FROM WATER WAVES

(51) International classification :F03B0013180000,
B60G0017015000,
H02K0035020000,
H02K0007180000,
F03G0007080000

(31) Priority Document No :NA
(32) Priority Date :NA
(33) Name of priority country :NA
(86) International Application No :NA
Filing Date :NA
(87) International Publication No : NA
(61) Patent of Addition to Application Number :NA
Filing Date :NA
(62) Divisional to Application Number :NA
Filing Date :NA

(71)**Name of Applicant :**
1)KLE Technological University
Address of Applicant :KLE Technological University B. V.
Bhoomaraddi Campus, Vidyanagar, Hubballi, Karnataka -580031,
India Karnataka India
2)DESHPANDE, Aditya Mahabaleshwar
3)SIDDAMAL, Saroja Virupakshappa

(72)**Name of Inventor :**
1)DESHPANDE, Aditya Mahabaleshwar
2)SIDDAMAL, Saroja Virupakshappa

(57) Abstract :

The present invention provides a Wave Energy Recovery System (WERS) (100) and method for recovering energy from water waves. The WERS comprises an energy recovery unit 101, which includes an oscillator mechanism 103 comprising a directional control valve 108 and a double acting cylinder 109, and a linear generator unit 104. The energy recovery unit 101 is integrated to an actuator 102 having a fluid and an actuator piston, wherein the actuator receives the mechanical energy from the waves, which causes the actuator piston to move and converts the fluid in the actuator into a pressurized fluid flow. The pressurized fluid flow passing through the directional control valve 108 enters into the double acting cylinder 109. The double acting cylinder 109 produces high frequency reciprocating linear motion, which is fed to the linear generator unit 104. The linear generator unit 104 converts the kinetic energy to electrical energy.

No. of Pages : 23 No. of Claims : 4

(54) Title of the invention : SYSTEM AND DESIGN OF SENSOR BASED ELECTRONIC VENTILATOR FOR COVID-19 PATIENTS

<p>(51) International classification :A61M0016000000, A61M0016100000, A61B0005000000, A61M0016160000, A61M0016120000</p> <p>(31) Priority Document No :NA (32) Priority Date :NA (33) Name of priority country :NA (86) International Application No :NA Filing Date :NA (87) International Publication No : NA (61) Patent of Addition to Application Number :NA Filing Date :NA (62) Divisional to Application Number :NA Filing Date :NA</p>	<p>(71)Name of Applicant : 1)Dr. Rajkumar Narayanan Address of Applicant :Assistant Professor, Department of Computer Science, St. Claret College, Jalahalli - 560013, Bengaluru, Karnataka, India Karnataka India 2)Zafrul Hasan 3)Sanjaya Kumar Sarangi 4)Rasmita Lenka 5)Radhika S Patil 6)Shwetha G 7)Vaishnavi Ajay Inamdar 8)Shryavani K 9)Dr. V. Tamizhazhagan 10)Vivek Veeraiah 11)Dr. Md. Khaja Mohiddin 12)Dr.S.Balamurugan</p> <p>(72)Name of Inventor : 1)Dr. Rajkumar Narayanan 2)Zafrul Hasan 3)Sanjaya Kumar Sarangi 4)Rasmita Lenka 5)Radhika S Patil 6)Shwetha G 7)Vaishnavi Ajay Inamdar 8)Shryavani K 9)Dr. V. Tamizhazhagan 10)Vivek Veeraiah 11)Dr. Md. Khaja Mohiddin 12)Dr.S.Balamurugan</p>
---	---

(57) Abstract :

System and Design of Sensor-Based Electronic Ventilator for COVID-19 Patients (SBEV) help the patients to make use of the SBEV to inhale the required oxygen safely and automatically based on different body measurements using various sensors. The ventilator is used to refine the O2 and CO2 gases frequently by using front and back movable pistons. The CO2 filter helps to absorb the CO2 gases from the ventilator to the patient. The fresh air is also inputted into the ventilator hose. The combined air and O2 have been passed through a humidifier to normalize the O2 with standard heat and humidity. One side valve helps to pass the gases in one way only. The various sensors are used to measure the different body values like temperature, heart rate, etc. to control the flow of O2 to the patients from the ventilator by the control unit. The ventilator outflow helps to move away from the CO2 gas from the ventilator. The SBEV control unit helps to monitoring and managing the successful functioning of the whole SBEV system. By using this SBEV, the patients to make use of the SBEV to inhale the required oxygen safely and automatically based on different body measurements using various sensors.

No. of Pages : 16 No. of Claims : 3

(12) PATENT APPLICATION PUBLICATION

(21) Application No.202141022387 A

(19) INDIA

(22) Date of filing of Application :19/05/2021

(43) Publication Date : 11/06/2021

(54) Title of the invention : SYSTEM FOR CASH DEPOSITING AND DISPENSING WITH AUTO SANITIZATION FUNCTIONALITY BASED ON THE INTERNET OF THINGS

<p>(51) International classification</p> <p>(31) Priority Document No</p> <p>(32) Priority Date</p> <p>(33) Name of priority country</p> <p>(86) International Application No</p> <p>Filing Date</p> <p>(87) International Publication No</p> <p>(61) Patent of Addition to Application Number:</p> <p>Filing Date</p> <p>(62) Divisional to Application Number</p> <p>Filing Date</p>	<p>:G07F0019000000, G07D0011000000, G07D0001020000, A61L0002240000, G07D0011245000</p> <p>:NA</p> <p>:NA</p> <p>:NA</p> <p>:NA</p> <p>:NA</p> <p>:NA</p> <p>:NA</p> <p>:NA</p> <p>:NA</p> <p>:NA</p>	<p>(71)Name of Applicant :</p> <p>1)Dr. Devi.A Address of Applicant :Assistant Professor, Reva University, School of Computer Science and Applications, Bangalore, India Karnataka India</p> <p>2)Dr. Kolachina Srinivas</p> <p>3)Dr. K. Bhavana Raj</p> <p>4)Ms.Charu Singh</p> <p>5)Dr. Vivek Kapur</p> <p>6)Dr. Smita Nirakhi</p> <p>7)Dr. Richa Gupta</p> <p>8)Mr. Sachin Dhull</p> <p>9)Smriti Sachan</p> <p>10)Mr. Dipesh Vaya</p> <p>11)Puja Acharya</p> <p>12)Mrs. Jyoti Gupta</p> <p>(72)Name of Inventor :</p> <p>1)Dr. Devi.A</p> <p>2)Dr. Kolachina Srinivas</p> <p>3)Dr. K. Bhavana Raj</p> <p>4)Ms.Charu Singh</p> <p>5)Dr. Vivek Kapur</p> <p>6)Dr. Smita Nirakhi</p> <p>7)Dr. Richa Gupta</p> <p>8)Mr. Sachin Dhull</p> <p>9)Smriti Sachan</p> <p>10)Mr. Dipesh Vaya</p> <p>11)Puja Acharya</p> <p>12)Mrs. Jyoti Gupta</p>
--	--	--

(57) Abstract :

The present invention relates to system for cash depositing and dispensing with auto sanitization functionality based on the internet of things. The objective of the present invention is to solve the problems in the prior art technologies of disinfecting the cash dispensing or deposit in an automatic teller machine.

No. of Pages : 26 No. of Claims : 5

(12) PATENT APPLICATION PUBLICATION

(21) Application No.202141022434 A

(19) INDIA

(22) Date of filing of Application :19/05/2021

(43) Publication Date : 11/06/2021

(54) Title of the invention : MULTI STAGE BLADE ROTOR FOR HORIZONTAL AXIS WIND TURBINE

<p>(51) International classification :F03D0009250000, F03D0001060000, F03D0003060000, F03D0001020000, F03D0003020000</p> <p>(31) Priority Document No :NA (32) Priority Date :NA (33) Name of priority country :NA (86) International Application No :NA Filing Date :NA (87) International Publication No : NA (61) Patent of Addition to Application Number :NA Filing Date :NA (62) Divisional to Application Number :NA Filing Date :NA</p>	<p>(71)Name of Applicant : 1)Dr.Praveen Mannam Address of Applicant :H.No: 102-2-411, Bonthapadu-(Village), Etukuru (Post), Guntur (Md & Dt), Andhra Pradesh-522017. Email id: praveen0216@gmail.com Mobile No: +91-7337065969 Andhra Pradesh India 2)Dr. NMG Kumar, Sree Vidyanikethan Engineering College 3)Saurabh Kumar Singh, S B JAIN INSTITUTE OF TECHNOLOGY MANAGEMENT AND RESEARCH 4)Dr. Chandrasekar K., SJB Institute of Tech 5)Dr. Shivappa H A, Dr. Ambedkar Institute of Technology 6)S.SENTHILMURUGAN, SRMIST 7)VISWANATHAN GANESH, Chalmers University of Technology 8)Hiran Gabriel D J, PSG college of Technology 9)Dr.Hasan Koten, Istanbul Medeniyet University 10)Dr.Sourabh Kumar Jain, Research Foundation of India 11)Dr.Makarand Upadhyaya, BITS, Pilani 12)Seerapu Varalakshmi, Dr.LANKAPALLI BULLAYYA COLLEGE OF ENGINEERING 13)M.Veerasundaram, SRI SAIRAM INSTITUTE OF TECHNOLOGY</p> <p>(72)Name of Inventor : 1)Dr.Praveen Mannam 2)Dr. NMG Kumar, Sree Vidyanikethan Engineering College 3)Saurabh Kumar Singh, S B JAIN INSTITUTE OF TECHNOLOGY MANAGEMENT AND RESEARCH 4)Dr. Chandrasekar K., SJB Institute of Tech 5)Dr. Shivappa H A, Dr. Ambedkar Institute of Technology 6)S.SENTHILMURUGAN, SRMIST 7)VISWANATHAN GANESH, Chalmers University of Technology 8)Hiran Gabriel D J, PSG college of Technology 9)Dr.Hasan Koten, Istanbul Medeniyet University 10)Dr.Sourabh Kumar Jain, Research Foundation of India 11)Dr.Makarand Upadhyaya, BITS, Pilani 12)Seerapu Varalakshmi, Dr.LANKAPALLI BULLAYYA COLLEGE OF ENGINEERING 13)M.Veerasundaram, SRI SAIRAM INSTITUTE OF TECHNOLOGY</p>
---	---

(57) Abstract :

Currently wind turbines have been intended to yield the kinetic energy from the wind and the same convert this kinetic energy into electrical energy. The favoured type of wind turbine for electricity generation purpose is a horizontal axis wind turbine (HAWT). The size of wind turbines and constituting components like blades grow up rapidly. As blades grow larger, the amount of reinforcement upsurges in a logarithmic progression. Size and cost of blades can be concentrated using rotor/blade supporting means. In this invention, joined blade rotor system specially for HAWT presented. This present invention also intended to provide light weight, low cost and high efficiency rotor system for horizontal axis wind turbine (HAWT). The rotor system may preferably include a number of joined blade assemblies spreading radially from a central hub having a considerably horizontal axis. Each joined blade assembly may preferably encompass at least two blades, a first blade and a second blade (or may comprise more blades) in dissimilar rotor planes. The first and second blades may rather be linked by one or more brace systems to each other.

No. of Pages : 12 No. of Claims : 3

(54) Title of the invention : APPARATUS FOR SANITIZING ARTICLES WITH ROTATABLE INNER CHAMBER TO EVENLY DISTRIBUTE UV RADIATION

<p>(51) International classification</p> <p>(31) Priority Document No</p> <p>(32) Priority Date</p> <p>(33) Name of priority country</p> <p>(86) International Application No Filing Date</p> <p>(87) International Publication No</p> <p>(61) Patent of Addition to Application Number Filing Date</p> <p>(62) Divisional to Application Number Filing Date</p>	<p>:A61L0002100000, F21V0007000000, A61L0002240000, H01J0061350000, A61L0002260000</p> <p>:NA</p> <p>:NA</p> <p>:NA</p> <p>:PCT// :01/01/1900</p> <p>: NA</p> <p>:NA</p> <p>:NA</p> <p>:NA</p> <p>:NA</p>	<p>(71)Name of Applicant :</p> <p>1)VAYU NANDANA KISHORE. PABBISSETTI Address of Applicant :Assistant Professor, Freshman Engineering Department, Lakireddy Balireddy College of Engineering, Mylavaram, Krishna District, Andhra Pradesh - 521230, India. Andhra Pradesh India</p> <p>2)ATRAGADA. CHITTI BABU</p> <p>3)JUJJAVARAPU. ASHOK</p> <p>4)PARITALA.RAGHAVA RAO</p> <p>5)NAGHAVARAPU. NARASIMHA RAO</p> <p>6)BHOGLI. JAYARAM SATYANARAYANA SWAMY</p> <p>7)NAKKA. RAJESWARA RAO</p> <p>8)PADAMATI.NARESH</p> <p>9)SRIKHAKOLANU. NAGA SURYA MANASA</p> <p>(72)Name of Inventor :</p> <p>1)VAYU NANDANA KISHORE. PABBISSETTI</p> <p>2)ATRAGADA. CHITTI BABU</p> <p>3)JUJJAVARAPU. ASHOK</p> <p>4)PARITALA.RAGHAVA RAO</p> <p>5)NAGHAVARAPU. NARASIMHA RAO</p> <p>6)BHOGLI. JAYARAM SATYANARAYANA SWAMY</p> <p>7)NAKKA. RAJESWARA RAO</p> <p>8)PADAMATI.NARESH</p> <p>9)SRIKHAKOLANU. NAGA SURYA MANASA</p>
--	---	--

(57) Abstract :

7. ABSTRACT An apparatus (100) for sanitizing articles with rotatable inner chamber to evenly distribute UV radiation is disclosed. The apparatus comprises of a cylindrical housing (2) with an acting inner wall, a top door (4), and an acting inner portion of a base (6). The apparatus comprises of two UV light (8a, 8b) sources disposed one on the acting inner wall of the said cylindrical housing (2) and one on the acting inner portion of the said base (6) of the cylindrical housing (2). The acting inner wall of the cylindrical housing (2) is surfaced with a highly reflecting layer and/or a coating. The said top door (4) is configured to selectively close and open for substantially sealing the cylindrical housing. The apparatus embraces an article placed in the cylindrical housing with the said electronic circuitry activating the UV lamp (8a, 8b) for a predetermined period of time, such that UV light from the light source and UV light (8a, 8b) reflected back into the cylindrical housing by the plurality of reflector layer illuminates the article for sanitizing the article (12). The figure associated with Abstract is Fig. 1.

No. of Pages : 13 No. of Claims : 5

(12) PATENT APPLICATION PUBLICATION

(21) Application No.202141022473 A

(19) INDIA

(22) Date of filing of Application :19/05/2021

(43) Publication Date : 11/06/2021

(54) Title of the invention : BIFACIAL BUCK BOOST POWER CONVERTER WITH CHARGING FACET FOR E-BIKE

(51) International classification	:G01R0031367000, H02P0006182000, H02M0003158000, H02J0007000000, H01L0031068000	(71) Name of Applicant : 1)Gopinath A Address of Applicant :Associate Professor, School of Electrical & Electronics Engineering, REVA University, Bangalore-560064 Karnataka India
(31) Priority Document No	:NA	2)Nagesh B K
(32) Priority Date	:NA	3)Sudhakar Rao P
(33) Name of priority country	:NA	(72) Name of Inventor :
(86) International Application No	:NA	1)Gopinath A
Filing Date	:NA	2)Nagesh B K
(87) International Publication No	: NA	3)Sudhakar Rao P
(61) Patent of Addition to Application Number	:NA	
Filing Date	:NA	
(62) Divisional to Application Number	:NA	
Filing Date	:NA	

(57) Abstract :

Electric-bikes or e-bikes are human-powered pedal-drive which combines the mechanical pedal-drive with electric motor actuated from an on-board rechargeable battery package in excess of the pedals. The rider or user can have a choice to use ride using pedals or using battery power or simultaneously. Recently, e-bikes has become most commodious, economical, and eco-friendly transportation mode for short distances, hence gain immense vogue in various countries. Normally, an energy management mechanism is very predominant for ameliorate the system efficiency and elongate the endurance. Therefore, well-crafted charging strategies with engulf the estimation approaches for tracking battery capacity are key facet in energy management of e- bikes. Thus, an economical and compact size integrated with SOC estimation Function and energy produced from the back electromotive force (BEMF) used for charging the battery by using bifacial power converter fed e-bike is proposed. The main layout is a series bi-facial buck-boost converter, which fetch the energy stored in battery for driving the e-bike and can recycle the energy produced from the back electromotive force (BEMF) of the motor (supplying back) to charge battery by changing the operation mode (either Buck or Boost Mode) by comparing the back emf and battery voltage. Additionally, the proposed converter can also set out as a charger cascaded with a rectifier circuit by connecting with AC source.

No. of Pages : 11 No. of Claims : 3

(54) Title of the invention : AN INSTRUMENT TO GO AGAINST SPOOFING ASSAULTS IN THE UTILIZATION OF ENGINEERED INSIGHT

<p>(51) International classification</p> <p>(31) Priority Document No</p> <p>(32) Priority Date</p> <p>(33) Name of priority country</p> <p>(86) International Application No Filing Date</p> <p>(87) International Publication No</p> <p>(61) Patent of Addition to Application Number Filing Date</p> <p>(62) Divisional to Application Number Filing Date</p>	<p>:H04L0029060000, G06N0003000000, G06N0020000000, G06F0021550000, H04L0009060000</p> <p>:NA</p> <p>:NA</p> <p>:NA</p> <p>:NA</p> <p>:NA</p> <p>:NA</p> <p>:NA</p> <p>:NA</p> <p>:NA</p> <p>:NA</p>	<p>(71)Name of Applicant :</p> <p>1)Dr. B. ANIRUDHAN Address of Applicant :Nehru Arts and Science College, (Autonomous), Nehru Gardens, T. M. Palayam, Coimbatore 641105, Tamil Nadu, India Tamil Nadu India</p> <p>2)SENTHIL KUMAR SEETHAPATHY</p> <p>3)Dr. N. SHANI</p> <p>4)Dr. S. SENTHIL KUMAR</p> <p>5)Dr. P. K. MANOJ KUMAR</p> <p>6)M. LEELAVATHI</p> <p>7)Dr. N. KAVITHA</p> <p>8)Dr. K. SELVAVINAYAKI</p> <p>9)Dr. D. VIMAL KUMAR</p> <p>(72)Name of Inventor :</p> <p>1)Dr. B. ANIRUDHAN</p> <p>2)SENTHIL KUMAR SEETHAPATHY</p> <p>3)Dr. N. SHANI</p> <p>4)Dr. S. SENTHIL KUMAR</p> <p>5)Dr. P. K. MANOJ KUMAR</p> <p>6)M. LEELAVATHI</p> <p>7)Dr. N. KAVITHA</p> <p>8)Dr. K. SELVAVINAYAKI</p> <p>9)Dr. D. VIMAL KUMAR</p>
--	--	--

(57) Abstract :

ABSTRACT AN INSTRUMENT TO GO AGAINST SPOOFING ASSAULTS IN THE UTILIZATION OF ENGINEERED INSIGHT Because of the ever-increasing complexities in cybercrimes, there is the want for cyber protection techniques to be more robust and sensible. this can make protection mechanisms to be capable of making actual-time decisions which could efficaciously respond to sophisticated attacks. mainly, the usage of synthetic intelligence for preventing cyber crimes. The ever-increasing risk of cyber attacks and crimes grew exponentially with latest improvements in artificial intelligence. it's been applied in nearly each discipline of sciences and engineering. From healthcare to robotics, AI has created a revolution. It turned into determined that artificial sensible methods have made excellent contributions to fighting cybercrimes with vast improvement in intrusion detection systems. It became additionally determined that there may be a reduction in computational complexity, model schooling times and fake alarms. wherein conventional security systems is probably sluggish and insufficient, artificial intelligence strategies can enhance their standard protection performance and provide higher protection from more and more sophisticated cyber threats. Beside the notable opportunities attributed to AI inside cyber protection, its use has justified dangers and concerns. To in addition boom the adulthood of cyber safety, a holistic view of businesses™ cyber surroundings is required wherein AI is mixed with human perception, considering neither human beings nor AI alone has verified universal achievement on this sphere. it is consequently recommended that to enhance studies in synthetic intelligence for CyberSec, need to undertake more recent techniques and also put up in other associated stores. Figure 2

No. of Pages : 11 No. of Claims : 4

(12) PATENT APPLICATION PUBLICATION

(21) Application No.202141022498 A

(19) INDIA

(22) Date of filing of Application :20/05/2021

(43) Publication Date : 11/06/2021

(54) Title of the invention : AN INTELLIGENT GUIDED PLAYER PERFORMANCE SYSTEM FOR SPORT FENCING

(51) International classification	:A63B0071060000, A63B0069360000, A63B0069020000, A63B0024000000, A63B0102320000	(71) Name of Applicant : 1)SpearAI Practice Private Limited Address of Applicant :J 58 Chaithanya Smaran, Whitefield Hoskote main road, Kannamangala, Bangalore, Karnataka Karnataka India
(31) Priority Document No	:NA	(72) Name of Inventor :
(32) Priority Date	:NA	1)Manisha Sriraman
(33) Name of priority country	:NA	2)Poorvi Sriraman
(86) International Application No	:PCT// /	
Filing Date	:01/01/1900	
(87) International Publication No	: NA	
(61) Patent of Addition to Application Number	:NA	
Filing Date	:NA	
(62) Divisional to Application Number	:NA	
Filing Date	:NA	

(57) Abstract :

AN INTELLIGENT GUIDED PLAYER PERFORMANCE SYSTEM FOR SPORT FENCING The present invention provides an intelligent guided player performance system for the sport of fencing that provides continuous and personalized player performance improvement capabilities to coaches and students. The intelligent guided player performance system of the present invention efficiently accounts for valid and invalid touches during practice sessions, based on the weapon used, through non-invasion methods, and records such data and converts it into data models which can be used to improve player performance.

No. of Pages : 16 No. of Claims : 5

(54) Title of the invention : A KIND OF RECTANGULAR PATCH ANTENNA USING MULTI-RESONANT SLOTS FOR BANDWIDTH IMPROVEMENT

<p>(51) International classification</p> <p>(31) Priority Document No</p> <p>(32) Priority Date</p> <p>(33) Name of priority country</p> <p>(86) International Application No</p> <p style="padding-left: 20px;">Filing Date</p> <p>(87) International Publication No</p> <p>(61) Patent of Addition to Application Number</p> <p style="padding-left: 20px;">Filing Date</p> <p>(62) Divisional to Application Number</p> <p style="padding-left: 20px;">Filing Date</p>	<p>:H01Q0009040000, H01Q0001380000, H01Q0001500000, H01Q0001480000, H01Q0005500000</p> <p>:NA</p> <p>:NA</p> <p>:NA</p> <p>:NA</p> <p>:NA</p> <p>: NA</p> <p>:NA</p> <p>:NA</p> <p>:NA</p> <p>:NA</p> <p>:NA</p>	<p>(71)Name of Applicant :</p> <p>1)BOLLAVATHI LOKESHWAR, RVRJCCE Address of Applicant :Assistant Professor, Department of ECE, R.V.R. & J.C. College of Engineering, Chowdavaram, Guntur, Andhra Pradesh India-522019 Andhra Pradesh India</p> <p>2)Mr.RAMESH DESHPADE, BVRIT</p> <p>3)Mrs. LANKA PADMALATHA, GEC</p> <p>4)Mrs. MADHAVI DEVI LANKA, PVPSIT</p> <p>5)Dr. E. GNANAMANO HARAN, ANNAMALAI UNIVERSITY</p> <p>6)Mrs. T. NIRMALA, SPMVV</p> <p>(72)Name of Inventor :</p> <p>1)BOLLAVATHI LOKESHWAR, RVRJCCE</p> <p>2)Mr.RAMESH DESHPADE, BVRIT</p> <p>3)Mrs. LANKA PADMALATHA, GEC</p> <p>4)Mrs. MADHAVI DEVI LANKA, PVPSIT</p> <p>5)Dr. E. GNANAMANO HARAN, ANNAMALAI UNIVERSITY</p> <p>6)Mrs. T. NIRMALA, SPMVV</p>
---	--	--

(57) Abstract :

The present invention discloses a kind of rectangular patch antenna using multi-resonant slots for bandwidth improvement 100. A rectangular patch 102 loaded with U-shaped slot 103 and defected ground structure are attached to top and bottom surfaces of the dielectric substrate 101, respectively. U-slot consists of two parallel vertical rectangular slots and a horizontal rectangular slot. To improve the impedance matching, a simple transformed unit 105 is placed between the microstrip line 104 and feed point. Ansoft HFSS software is used to design and simulate the proposed antenna, which exhibits multi-resonant characteristics with the inclusion of several structures which are termed as multi-resonant structures. The notch band of 5.26 GHz (impedance bandwidth of 0.8 GHz) is observed by introducing U-slot 103 and the corresponding gain is 4.587 dB at 7 GHz. The notch band antenna eliminates the interference caused by WLAN systems.

No. of Pages : 15 No. of Claims : 8

(12) PATENT APPLICATION PUBLICATION

(21) Application No.202141022523 A

(19) INDIA

(22) Date of filing of Application :20/05/2021

(43) Publication Date : 11/06/2021

(54) Title of the invention : MILK ANALYZER APPARATUS

(51) International classification	:G01N0033040000, A01J0005040000, A01J0005013000, G01N0033060000, G01N0021780000	(71) Name of Applicant : 1)Babumon Gopi Address of Applicant :~Sreehari™ Near Ayini Temple, Ayini Temple Road, Maradu P.O, Ernakulam. Kerala India
(31) Priority Document No	:NA	(72) Name of Inventor : 1)Babumon Gopi
(32) Priority Date	:NA	
(33) Name of priority country	:NA	
(86) International Application No	:NA	
Filing Date	:NA	
(87) International Publication No	: NA	
(61) Patent of Addition to Application Number	:NA	
Filing Date	:NA	
(62) Divisional to Application Number	:NA	
Filing Date	:NA	

(57) Abstract :

Title: Milk Analyzer Apparatus. A milk analyzer apparatus configured to simultaneously measure Fat content and corrected lactometer reading of raw milk within a very short time frame is disclosed. A part of the milk sample is passed through an oscillating U-tube (2) to calculate the CLR content whereas another part of the milk sample is mixed with EDTA solution, wherein said milk-EDTA mixture it is subjected to optical analysis in an optical sensor assembly (16) unit to determine the Fat content. A microcontroller unit (21) controls and regulates the operation of the various components of the apparatus, as well as computing the CLR and Fat content of the milk sample. FIG.1

No. of Pages : 25 No. of Claims : 9

(12) PATENT APPLICATION PUBLICATION

(21) Application No.202141022529 A

(19) INDIA

(22) Date of filing of Application :20/05/2021

(43) Publication Date : 11/06/2021

(54) Title of the invention : CLOUD AND IOT BASED ALCOHOL AND HEALTH MONITORING SYSTEM

(51) International classification	:A61B0005000000, H04L0029080000, G01R0019250000, B60R0021010000, A61B0005180000	(71)Name of Applicant : 1)Dr.AR.Sivakumaran Address of Applicant :Professor Department of Information Technology Malla Reddy Engineering College for Women, Secunderabad-500100. Tamil Nadu India 2)Dr.M.Vanitha 3)Dr.P.T.Vasanth Raj 4)Dr.Hemanta Kumar Bhuyan 5)Mr.D.Selvapandian 6)Dr Sundara Pandiyan S 7)Dr.Jebakumar Immanuel D
(31) Priority Document No	:NA	(72)Name of Inventor : 1)Dr.AR.Sivakumaran 2)Dr.M.Vanitha 3)Dr.P.T.Vasanth Raj 4)Dr.Hemanta Kumar Bhuyan 5)Mr.D.Selvapandian 6)Dr Sundara Pandiyan S 7)Dr.Jebakumar Immanuel D
(32) Priority Date	:NA	
(33) Name of priority country	:NA	
(86) International Application No	:NA	
Filing Date	:NA	
(87) International Publication No	: NA	
(61) Patent of Addition to Application	:NA	
Number	:NA	
Filing Date	:NA	
(62) Divisional to Application Number	:NA	
Filing Date	:NA	

(57) Abstract :

Wireless alcohol and health monitoring system that can monitor a human 24x7. Vehicle driving to manufacturing plants, Offices, Hospitals, Military, and other such ventures need to screen their staff/faculty follow all hard-working attitudes that incorporate, not coming to premises affected by liquor. This guarantees legitimate hard-working attitudes are followed. Our proposed framework takes into consideration liquor and wellbeing checking in addition to a detailing framework that screens this and reports it to concerned staff distantly over the web. Our framework comprises an IOT based circuit framework that utilizes a microcontroller-based circuit framework. The framework has liquor just as pulse observing sensors to check for liquor utilization just as improper circulatory strain checking. This guarantees no events of mishaps because of liquor impact or unpleasant medical issues. This system consists of addiction to alcohol finding with health monitoring. Controlling and processing is completed through the Arduino Uno board, all the sensors are connected to Arduino UNO. Through this technique, we will measure ECG, heartbeat, BP, and spo2. Through sensors, it is possible to live off these values. Here all the sensors are powered employing a solar energy system. these analog sensors are often connected to Arduino through any of the six analog pins. These values are then used for detecting any critical situation. within the case of a critical situation, an alert is often given as a message. Also, it's possible to watch the personTMs health from any location within the world through the cloud. Data from sensors is uploaded to the cloud periodically with no interruption if the web is out there. Here ESP8266 wifi module is employed for connecting Arduino to the web.

No. of Pages : 6 No. of Claims : 2

(12) PATENT APPLICATION PUBLICATION

(21) Application No.202141022539 A

(19) INDIA

(22) Date of filing of Application :20/05/2021

(43) Publication Date : 11/06/2021

(54) Title of the invention : SYSTEM AND METHOD FOR TRAFFIC PREDICTION

(51) International classification	:G01C0021340000, G08G0001010000, G01C0021360000, H04L0012851000, G06N0020000000	(71) Name of Applicant : 1)Suvitha D Address of Applicant :Anna University CEG campus, Chennai - 600025 Tamil Nadu India
(31) Priority Document No	:NA	(72) Name of Inventor : 1)Suvitha D
(32) Priority Date	:NA	
(33) Name of priority country	:NA	
(86) International Application No	:NA	
Filing Date	:NA	
(87) International Publication No	: NA	
(61) Patent of Addition to Application Number	:NA	
Filing Date	:NA	
(62) Divisional to Application Number	:NA	
Filing Date	:NA	

(57) Abstract :

The disclosed invention relates to a system and a method of predicting traffic. The disclosed invention provides a robust and effective traffic prediction system using decision tree classifier. The disclosed invention provides a system (100) comprising: data receiving unit (108) configured to receive traffic data; a data storage unit (110) configured to create a lookup table in a database (104); a processing unit (112) configured to: partition training data; discard dependencies on statistical noise and/or anomalies in the traffic data; predict traffic range for one or more routes based on the traffic data using a decision tree classifier; predict an optimal route from the one or more routes; and generate a map using one or more third party product and service providers based on the predicted optimal route; a display unit (116) communicably connected to at least one of the user devices (106a-106m) and configured to display the generated map.

No. of Pages : 18 No. of Claims : 10

(54) Title of the invention : FLOOD RESCUE OPERATION USING INTELLIGENT DRONE FOR SUPPORTING DISASTER MANAGEMENT

(51) International classification	:B64C0039020000, G08B0025010000, G08B0027000000, G08B0025140000, G06Q0010060000	(71) Name of Applicant : 1)Mahesh Kumar Address of Applicant :Assistant Professor School of Electrical & Electronics Engineering, REVA University, Bangalore-64 Karnataka India
(31) Priority Document No	:NA	2)Dhanush P Shetty
(32) Priority Date	:NA	3)Bharath Rao N
(33) Name of priority country	:NA	4)Bhargav S
(86) International Application No	:NA	5)Hemanth L
Filing Date	:NA	(72) Name of Inventor :
(87) International Publication No	: NA	1)Mahesh Kumar
(61) Patent of Addition to Application Number	:NA	2)Dhanush P Shetty
Filing Date	:NA	3)Bharath Rao N
(62) Divisional to Application Number	:NA	4)Bhargav S
Filing Date	:NA	5)Hemanth L

(57) Abstract :

ABSTRACT Flood is such an adverse natural calamity which can washaway several people and houses from their location within a short span. It can even submerge the whole low altitude areas under the water which makes it even harder to locate exact location of the human habitation. The submergence of the area will easily change the terrain and itTMs hard to get the knowledge of whatTMs beneath the water. This project uses an Unmanned Aerial Vehicle (UAV) to quickly fly over an area and detect people stranded in multiple areas and send their location data using Global Positioning System (GPS) module back to the control center where they can mark the coordinates in the flood affected areaTMs map and categorize the severity of the rescue plan on priority basis. The system also has a speaker in the UAV which will help the first responders communicate with the people by providing valuable information regarding the situation. The model will have a UAV, communication system and live video streaming system. The first responders will move to the location and to assess the situation like number of people stranded, boat routes planning and to do routine checks, they can use the UAV and its accessories to plan their action in an efficient way. It will have an on-board communication system to have half-duplex communication with the survivors and first responders. To make the disaster management easier and rescue planning faster, we have used a computer vision library tool which detects people and sends their location back to the control center.

No. of Pages : 13 No. of Claims : 3

(54) Title of the invention : MACHINE LEARNING SUPPORTED PREDICTIVE SYSTEM AND METHOD OF ANALYZING THE EMOTION OF CUSTOMERS THEREOF

<p>(51) International classification</p> <p>(31) Priority Document No</p> <p>(32) Priority Date</p> <p>(33) Name of priority country</p> <p>(86) International Application No Filing Date</p> <p>(87) International Publication No</p> <p>(61) Patent of Addition to Application Number Filing Date</p> <p>(62) Divisional to Application Number Filing Date</p>	<p>:G06Q0030020000, G06Q0030060000, H04N0005232000, G06Q0010060000, H04W0004000000</p> <p>:NA</p> <p>:NA</p> <p>:NA</p> <p>:NA</p> <p>:NA</p> <p>: NA</p> <p>:NA</p> <p>:NA</p> <p>:NA</p> <p>:NA</p>	<p>(71)Name of Applicant :</p> <p>1)Dr. VEMPATI KRISHNA Address of Applicant :Professor, Department of Computer Science and Engineering, TKR college of Engineering and Technology, Saroornagar, Hyderabad Telangana India</p> <p>2)Dr. V. L. PAVANI</p> <p>3)Dr. M. I. THARIQ HUSSAN</p> <p>4)Dr. N. NALINI</p> <p>5)Mr. P. NARESH</p> <p>6)Ms. APARNA MANIKONDA</p> <p>7)Mr. VORUGANTI RAMESH</p> <p>8)Dr. A. L. SREENIVASULU</p> <p>(72)Name of Inventor :</p> <p>1)Dr. VEMPATI KRISHNA</p> <p>2)Dr. V. L. PAVANI</p> <p>3)Dr. M. I. THARIQ HUSSAN</p> <p>4)Dr. N. NALINI</p> <p>5)Mr. P. NARESH</p> <p>6)Ms. APARNA MANIKONDA</p> <p>7)Mr. VORUGANTI RAMESH</p> <p>8)Dr. A. L. SREENIVASULU</p>
--	---	---

(57) Abstract :

The present invention relates to a customer behavior predictive system to facilitate displaying of appropriate products while browsing the sites, more particularly machine learning supported emotion analysis system considering the spending pattern, browsing history, idle time spent, ad-popup time and response in real-time, effectively, comprising an internet of things enabled standalone device, said standalone device [100a, 100b and 100c] interfaced with a camera device along with an image processing module to capture the activities, interactions, and facial expressions and a display unit, an internet server, said internet server [200] wirelessly connected with the said standalone device, an a mobile phone device, said mobile phone device [300] displayed the processed data delivered by the said internet server. FIGURE 1

No. of Pages : 19 No. of Claims : 10

(12) PATENT APPLICATION PUBLICATION

(21) Application No.202141022696 A

(19) INDIA

(22) Date of filing of Application :21/05/2021

(43) Publication Date : 11/06/2021

(54) Title of the invention : INTERNET OF THINGS AND ARTIFICIAL INTELLIGENCE BASED INTELLIGENT VEHICLE CONTROLLED RESCUE SYSTEM FOR EPILEPSY PATIENTS

<p>(51) International classification :G06F0016951000, G06N0003080000, H04N0007180000, H04L0029080000, G06Q0050180000</p> <p>(31) Priority Document No :NA (32) Priority Date :NA (33) Name of priority country :NA (86) International Application No :NA Filing Date :NA (87) International Publication No : NA (61) Patent of Addition to Application Number:NA Filing Date :NA (62) Divisional to Application Number :NA Filing Date :NA</p>	<p>(71)Name of Applicant : 1)Dr.Reshma V.K Address of Applicant :Assistant Professor, Department of Computer Science and Engineering, Jawaharlal College of Engineering and Technology, Jawahar Gardens,Lakkidi, Mangalam, Ottapalam, Kerala, India Kerala India 2)Ms.Charu Singh 3)Dr. Aleem Ali 4)Dr. Navaid Zafar Rizvi 5)Dr. Meena Rao 6)Dr. Pooja Malik 7)Dr. Raviranjn Kr. Singh 8)Dr. Vineet Kumar Singh 9)Dr. Anubhav Kumar Prasad 10)Dr. Dharm Raj Singh 11)Dr. Pavithra G. 12)Prof. Anupama T.A.</p> <p>(72)Name of Inventor : 1)Dr.Reshma V.K 2)Ms.Charu Singh 3)Dr. Aleem Ali 4)Dr. Navaid Zafar Rizvi 5)Dr. Meena Rao 6)Dr. Pooja Malik 7)Dr. Raviranjn Kr. Singh 8)Dr. Vineet Kumar Singh 9)Dr. Anubhav Kumar Prasad 10)Dr. Dharm Raj Singh 11)Dr. Pavithra G. 12)Prof. Anupama T.A.</p>
--	--

(57) Abstract :

The present invention relates to internet of things and artificial intelligence based intelligent vehicle controlled rescue system for epilepsy patients. The objective of the present invention is to solve the problems in the prior art technologies of driverTMs health monitoring and automatically stop the car according to the abrupt attack of epilepsy.

No. of Pages : 30 No. of Claims : 4

(12) PATENT APPLICATION PUBLICATION

(21) Application No.202141022852 A

(19) INDIA

(22) Date of filing of Application :21/05/2021

(43) Publication Date : 11/06/2021

(54) Title of the invention : DEVELOPMENT OF LOW COST SOLAR POWERED SMART TRAP: AN INTEGRATED PEST MANAGEMENT

(51) International classification	:A01M0001100000, A01M0001020000, A01M0001040000, A01N0025180000, A01M0001200000	(71) Name of Applicant : 1)Dr. KATARAKI PRAMODKUMAR S Address of Applicant :Associate Professor, School Of Mechanical Engineering, REVA University, Rukmini Knowledge Park Kattigenahalli, Yelhanka, Bangalore. 560064. Karnataka. Karnataka India
(31) Priority Document No	:NA	(72) Name of Inventor :
(32) Priority Date	:NA	1)Dr. KATARAKI PRAMODKUMAR S
(33) Name of priority country	:NA	2)Dr. Ahmad Faiz Bin Zubair
(86) International Application No	:NA	3)Dr. Jamaluddin Bin Abdullah
Filing Date	:NA	4)Dr. Ahmed A. Hussien
(87) International Publication No	: NA	5)Dr. Isam Qasem
(61) Patent of Addition to Application Number	:NA	6)Dr. Ayub Ahmed Janvekar
Filing Date	:NA	7)Mr. Syed Anas Quadri
(62) Divisional to Application Number	:NA	8)Mr. Vineeth Kumar D
Filing Date	:NA	9)Mr. Jeeva S
		10)Ms. Kruthi J.R

(57) Abstract :

The indiscriminate usage of pesticides to control insect pest population has led to production of pesticide residue and pest damaged crops, therefore IPM aims to reduce indiscriminate usage of pesticides by using parasitoids, traps. The open traps (delta, jackson, sticky) significantly attract non-target insect pests and dust particles thereby leading to inefficient crop scouting. While enclosed traps (funnel, McPhail) set up with pheromone lures attract target insect pests and avoid significant attraction of non-target insect pests, but depend on crop scouting for pest identification. To eliminate inefficient crop scouting, identification of camera captured insect pests by SVM technique was developed. But ambient light conditions, plant orientations, hiding place of insect pests leads to generation of low quality camera images. Here, efforts are made to develop a Solar Powered Smart trap that performs efficiently and overcomes inefficient crop scouting by automatically camera capturing and counting of trapped insect pests.

No. of Pages : 4 No. of Claims : 3

(12) PATENT APPLICATION PUBLICATION

(21) Application No.202141022856 A

(19) INDIA

(22) Date of filing of Application :21/05/2021

(43) Publication Date : 11/06/2021

(54) Title of the invention : REAL TIME PATIENT HEALTH MONITORING AND INDICATION TO DOCTORS USING IOT

(51) International classification	:A61B0005000000, G16H0050300000, H04L0029080000, A61B0005020500, A61B0005110000	(71) Name of Applicant : 1)Dr. Kalpana Murugan Address of Applicant :Professor and Head Department of Electronics and Communication Engineering Kalasalingam Academy of Research And Education, Anand Nagar, Krishnankoil-626126, Tamil Nadu, India. Tamil Nadu India 2)Dr. V. Muneeswaran 3)Mrs. S. Murugeswari 4)Mr. A. Rahul Kumar Reddy 5)Mr. T. Monish kumar 6)Mr. P. Ammaar
(31) Priority Document No	:NA	(72) Name of Inventor : 1)Dr. Kalpana Murugan 2)Dr. V. Muneeswaran 3)Mrs. S. Murugeswari 4)Mr. A. Rahul Kumar Reddy 5)Mr. T. Monish kumar 6)Mr. P. Ammaar
(32) Priority Date	:NA	
(33) Name of priority country	:NA	
(86) International Application No	:NA	
Filing Date	:NA	
(87) International Publication No	: NA	
(61) Patent of Addition to Application Number	:NA	
Filing Date	:NA	
(62) Divisional to Application Number	:NA	
Filing Date	:NA	

(57) Abstract :

Remote based health monitoring diagnosis in medial field requires more number of sensors and human efforts if it is processed in a large extent. It is a hard task due to the shortage of medical professionals and system setup. To overcome this issue an IoT based health care application is proposed in the research work. The proposed method consists of the web and mobile application based on continuous wireless monitoring of patients. The objective is to implement a low-cost system and transmit the patient unconditional signs in emergency situations. Sensors are being used for measuring the patient unconditional signs by using the wireless network. The sensors data are collected and transmitted to the cloud for storage via Wi-Fi module connected with the controller. The data is processed in the cloud and feedback steps are taken on the analysed data which can be further analysed by a doctor remotely. Remote viewing reduces burden to doctors and provides the exact health status of patient condition and it is sent to the doctor.

No. of Pages : 7 No. of Claims : 4

(12) PATENT APPLICATION PUBLICATION

(21) Application No.202141022867 A

(19) INDIA

(22) Date of filing of Application :21/05/2021

(43) Publication Date : 11/06/2021

(54) Title of the invention : METHOD TO UTILISE VEHICLE AREA IN PLATOON MANAGEMENT FOR ENERGY EFFICIENCY

(51) International classification	:B62D0035000000, G01V0005000000, G07B0015060000, G08G0001070000, F03G0007080000	(71) Name of Applicant : 1)M S Sunitha Patel Address of Applicant :Door No.02, 19th Block, Dr.Rajkumar Road, Near BSNL Office, JSS Layout, Mysuru-570019 Karnataka India
(31) Priority Document No	:NA	(72) Name of Inventor :
(32) Priority Date	:NA	1)M S Sunitha Patel
(33) Name of priority country	:NA	
(86) International Application No	:NA	
Filing Date	:NA	
(87) International Publication No	: NA	
(61) Patent of Addition to Application Number	:NA	
Filing Date	:NA	
(62) Divisional to Application Number	:NA	
Filing Date	:NA	

(57) Abstract :

The invention relates to a method which utilize the vehicle area for optimal vehicle combination with two or more vehicles while moving in longitudinal direction. The invention also relates to vehicles for such a method. The invention can be applied in all road vehicles, where air drag is found in moving vehicle because of the area which resists the vehicle movement. The invention can be applied to achieve energy efficiency on all road vehicles which are propelled by conventional or non-conventional energies.

No. of Pages : 16 No. of Claims : 7

(12) PATENT APPLICATION PUBLICATION

(21) Application No.202141022882 A

(19) INDIA

(22) Date of filing of Application :21/05/2021

(43) Publication Date : 11/06/2021

(54) Title of the invention : RAIDAL AXIS ACTIVE-MAGNETO-RHEOLOGICAL TOOL DAMPER FOR BORING OPERATIONS

(51) International classification	:F16F0009530000, B23Q0011000000, C08K0005000000, B60G0017060000, F16F0015020000	(71) Name of Applicant : 1)S. Lakshmana kumar Address of Applicant :150/1, Srinagar, Aravinthar Ashramam Road, Narasothipatty, Salem Tamil Nadu India 2)Saranya S N 3)Rajan Raj Jawahar
(31) Priority Document No	:NA	(72) Name of Inventor :
(32) Priority Date	:NA	1)S. Lakshmana kumar
(33) Name of priority country	:NA	2)Saranya S N
(86) International Application No	:NA	3)Rajan Raj Jawahar
Filing Date	:NA	
(87) International Publication No	: NA	
(61) Patent of Addition to Application Number	:NA	
Filing Date	:NA	
(62) Divisional to Application Number	:NA	
Filing Date	:NA	

(57) Abstract :

The invention relates to a fully active damping system, preferably for use in any machining operations. The varying amplitude of vibrations induced during machining operation is converted into voltage by a pre-programmed microcontroller which in turn used to vary the viscosity of the magneto-rheological fluid and flow rate of fluid in the electromagnetic chamber. This process activates the damper which minimizes the vibration produced during machining.

No. of Pages : 19 No. of Claims : 6

(12) PATENT APPLICATION PUBLICATION

(21) Application No.202141022885 A

(19) INDIA

(22) Date of filing of Application :22/05/2021

(43) Publication Date : 11/06/2021

(54) Title of the invention : Colourless Turmerones and Their Extraction Method Thereof

(51) International classification	:G06T0007900000, A61K0036899800, G01N0033360000, A61K0033000000, G06K0009460000	(71) Name of Applicant : 1)Mr. Chamalla Tirumalarao Address of Applicant :Door No: 27-256, Panchayat Officer's Colony, Appannapalem, Vepagunta, Visakhapatnam, Andhra Pradesh, India- 530047. Andhra Pradesh India
(31) Priority Document No	:NA	(72) Name of Inventor :
(32) Priority Date	:NA	1)Mr. Chamalla Tirumalarao
(33) Name of priority country	:NA	
(86) International Application No	:PCT//	
Filing Date	:01/01/1900	
(87) International Publication No	: NA	
(61) Patent of Addition to Application Number	:NA	
Filing Date	:NA	
(62) Divisional to Application Number	:NA	
Filing Date	:NA	

(57) Abstract :

ABSTRACT: Title: Colourless Turmerones and Their Extraction Method Thereof The present disclosure proposes colourless turmerones and their extraction method thereof. The proposed method extracts colourless turmerones that does not form stains on the applied area and encourages use of turmerones. The colourless turmerones is applied on any substance or body or cloth and no visible colour or stain is formed on any surface, and the medicinal properties and efficacy of the colourless turmerones are retained. The proposed method extracts colourless turmerones which is helpful in preventive care, health maintenance, and slowing age-related degeneration. The extracted colourless turmerones does not stain on clothes of users.

No. of Pages : 16 No. of Claims : 6

(12) PATENT APPLICATION PUBLICATION

(21) Application No.202141022887 A

(19) INDIA

(22) Date of filing of Application :22/05/2021

(43) Publication Date : 11/06/2021

(54) Title of the invention : INTERNET OF THINGS BASED EBOLA VIRUS DETECTION AMONG MASSES

(51) International classification	:G06N0003000000, G06N0020000000, H04W0084180000, C07K0016100000, G06N0003020000	(71)Name of Applicant : 1)Dr. PANEM CHARANARUR Address of Applicant :H. NO. 97, NEAR SANTHERI VIDYALAYA, HANKON, KARWAR (U.K), KARNATAKA 581301 Karnataka India 2)Mr. DEEPAK SHRIPAT MANE 3)Dr. V. S. MANJULA 4)Mr. A. RANJITH 5)Dr. HARIKUMAR PALLATHADKA 6)Dr.ANITA VENAİK 7)Dr. KEYURKUMAR M NAYAK
(31) Priority Document No	:NA	(72)Name of Inventor : 1)Dr. PANEM CHARANARUR 2)Mr. DEEPAK SHRIPAT MANE 3)Dr. V. S. MANJULA 4)Mr. A. RANJITH 5)Dr. HARIKUMAR PALLATHADKA 6)Dr.ANITA VENAİK 7)Dr. KEYURKUMAR M NAYAK
(32) Priority Date	:NA	
(33) Name of priority country	:NA	
(86) International Application No	:PCT//	
Filing Date	:01/01/1900	
(87) International Publication No	: NA	
(61) Patent of Addition to Application	:NA	
Number	:NA	
Filing Date	:NA	
(62) Divisional to Application Number	:NA	
Filing Date	:NA	

(57) Abstract :

The health sector also opts for new scientific advances to track and diagnose Ebola Virus, which is currently in turmoil around the world. Artificial Intelligence is one way to control virus replication and the possibility of transmission in real-time. Artificial Intelligence technology can be an efficient approach. However, it is difficult to track individuals because Artificial Intelligence needs to undergo even more adjustments and the IoT sensors provide an ample feedback request. The proposal allows Bluetooth controlled sensors (Bluetooth Version 5.2 or BTV5.2) to be used to tackle the current crisis and allow quicker analysis by Artificial Intelligence for data collection by a person and sends the data to the processing engine to detect if an individual is infected or not. Both IoT-enabled Bluetooth modules sensors are combined with mobile phone cases to make the transport of people simpler. An embedded Artificial Intelligence module can process the status of the person and submit the information to the municipal authority or the nearest hospitals. The Artificial Intelligence controlled smartphone device allows patients to be monitored in real-time and limits the outbreak.

No. of Pages : 12 No. of Claims : 8

(12) PATENT APPLICATION PUBLICATION

(21) Application No.202141022889 A

(19) INDIA

(22) Date of filing of Application :22/05/2021

(43) Publication Date : 11/06/2021

(54) Title of the invention : MONITORING AND DETECTION OF COVID-19 PATIENTS USING INTERNET OF THINGS

(51) International classification	:A61B0005000000, A61B0005024000, G06Q0050220000, A61B0005010000, A61B0005145000	(71)Name of Applicant : 1)Dr. G.R.RAGHAV Address of Applicant :ASSOCIATE PROFESSOR,DEPARTMENT OF MECHANICAL ENGINEERING,SCMS SCHOOL OF ENGINEERING AND TECHNOLOGY, VIDYA NAGAR, PALISSERY, KARUKUTTY, ERNAKULAM-683576 Kerala India 2)Mr. DEEPAK SHRIPAT MANE 3)Dr. V. S. MANJULA 4)Mr. A. RANJITH 5)Dr. R. RAJ MOHAN 6)Dr. HARIKUMAR PALLATHADKA 7)Mr.ATUL BHARDWAJ
(31) Priority Document No	:NA	(72)Name of Inventor :
(32) Priority Date	:NA	1)Dr. G.R.RAGHAV
(33) Name of priority country	:NA	2)Mr. DEEPAK SHRIPAT MANE
(86) International Application No	:PCT//	3)Dr. V. S. MANJULA
Filing Date	:01/01/1900	4)Mr. A. RANJITH
(87) International Publication No	: NA	5)Dr. R. RAJ MOHAN
(61) Patent of Addition to Application	:NA	6)Dr. HARIKUMAR PALLATHADKA
Number	:NA	7)Mr.ATUL BHARDWAJ
Filing Date	:NA	
(62) Divisional to Application Number	:NA	
Filing Date	:NA	

(57) Abstract :

The coronavirus outbreak is a threat to humanity in recent times that disrupts the global healthcare systems. The healthcare and government policies make utmost concern in preventing the infectious spread and in reducing the rate of infections in humans. In such cases, the monitoring and detection of infections across different organs in the human body are essential that may provide the original value of their heart rate and oxygen level. Further, various other parameters like blood sugar level and blood pressure are essentially monitored and safe diagnosis is carried out to save their lives. In this project, the interconnected Internet of Thing (IoT) based smart bands are used for pulse rate detection, oxygen level, and blood sugar levels. Such estimation would enable the patients to reduce the rate of infections via suitable medicines.

No. of Pages : 13 No. of Claims : 8

(12) PATENT APPLICATION PUBLICATION

(21) Application No.202141022914 A

(19) INDIA

(22) Date of filing of Application :22/05/2021

(43) Publication Date : 11/06/2021

(54) Title of the invention : SYSTEM AND METHOD FOR CROP AND FERTILIZER RECOMMENDATION THROUGH SOIL NUTRIENT MONITORING USING CYBER PHYSICAL SYSTEM AND MACHINE LEARNING

<p>(51) International classification :C05G0003000000, G01N0033240000, A01C0021000000, A01B0079000000, A01C0023040000</p> <p>(31) Priority Document No :NA</p> <p>(32) Priority Date :NA</p> <p>(33) Name of priority country :NA</p> <p>(86) International Application No :PCT// Filing Date :01/01/1900</p> <p>(87) International Publication No : NA</p> <p>(61) Patent of Addition to Application Number :NA Filing Date :NA</p> <p>(62) Divisional to Application Number :NA Filing Date :NA</p>	<p>(71)Name of Applicant :</p> <p>1)Dr. Ajit Danti Address of Applicant :Professor, Department of Computer Science and Engineering, School of Engineering and Technology, Christ (Deemed to Be University), Bangalore, India Karnataka India</p> <p>2)Dr. Balachandran Krishnan</p> <p>3)Dr. Suresha M</p> <p>4)Dr. Sujatha A K</p> <p>5)Prof. Manohar Madgi</p> <p>6)Dr. VG. Ravindhren</p> <p>7)Dr. Sapna Katiyar</p> <p>8)Dr. Vinayendra Mani Tripathi</p> <p>9)Dr. Soojey Ramchandra Deshpande</p> <p>10)Mrs. Sonu Rana</p> <p>11)Mrs. Monika Dhiman</p> <p>12)Mrs. Anu Prakash</p> <p>(72)Name of Inventor :</p> <p>1)Dr. Ajit Danti</p> <p>2)Dr. Balachandran Krishnan</p> <p>3)Dr. Suresha M</p> <p>4)Dr. Sujatha A K</p> <p>5)Prof. Manohar Madgi</p> <p>6)Dr. VG. Ravindhren</p> <p>7)Dr. Sapna Katiyar</p> <p>8)Dr. Vinayendra Mani Tripathi</p> <p>9)Dr. Soojey Ramchandra Deshpande</p> <p>10)Mrs. Sonu Rana</p> <p>11)Mrs. Monika Dhiman</p> <p>12)Mrs. Anu Prakash</p>
--	--

(57) Abstract :

The present invention relates to system and Method for crop and fertilizer recommendation through soil nutrient monitoring using cyber physical system and machine learning. The objective of the present invention is to solve the problems in the prior art technologies of crop and fertilizer recommendation based on soil nutrient, soil type and agriculture field location.

No. of Pages : 30 No. of Claims : 7

(54) Title of the invention : IOT ENABLED SMART AND SECURE E-CAMPUS

<p>(51) International classification</p> <p>(31) Priority Document No</p> <p>(32) Priority Date</p> <p>(33) Name of priority country</p> <p>(86) International Application No Filing Date</p> <p>(87) International Publication No</p> <p>(61) Patent of Addition to Application Number Filing Date</p> <p>(62) Divisional to Application Number Filing Date</p>	<p>:H04L0029080000, F21V0033000000, H02J0003000000, H04W0004700000, G06Q0050200000</p> <p>:NA</p> <p>:NA</p> <p>:NA</p> <p>:PCT// :01/01/1900</p> <p>: NA</p> <p>:NA</p> <p>:NA</p> <p>:NA</p> <p>:NA</p>	<p>(71)Name of Applicant :</p> <p>1)Dr. Jereesha Mary S J Address of Applicant :Professor, Annai Velankanni College of Engineering, Kanyakumari District, TamilNadu. Tamil Nadu India</p> <p>2)Dr. Sebastin Antony Joe, 3)Mr.Haydar Sabeeh Kalash 4)Dr.Ronald S. Cordova 5)Mr.Suresh Palarimath 6)Ms.Tamilarasi 7)Ms. Anish Pon Yamini K 8)Ms. Manju V M 9)Dr.S.Brilly Sangeetha 10)Dr. Wilfred Blessing N .R</p> <p>(72)Name of Inventor :</p> <p>1)Dr. Jereesha Mary S J 2)Dr. Sebastin Antony Joe, 3)Mr.Haydar Sabeeh Kalash 4)Dr.Ronald S. Cordova 5)Mr.Suresh Palarimath 6)Ms.Tamilarasi 7)Ms. Anish Pon Yamini K 8)Ms. Manju V M 9)Dr.S.Brilly Sangeetha 10)Dr. Wilfred Blessing N .R</p>
--	---	---

(57) Abstract :

ABSTRACT IOT enabled smart and secure e-campus Internet of Things is considered as a cloud-based global network connecting different things through sensors. The IoT integrates several devices that interact with other items, computers, infrared, and the atmosphere in an intelligent way. This notion of innovation emphasizes the essential elements of a 'smart and safe education campus' model, and The Internet-of-Things (IoT) infrastructure enables an intelligent campus. An intelligent campus connects servers, peripherals, campus facilities, and internet connectivity for users. And the smart campus uses the IoT networks to link campus assets to the IP network, including exterior lighting, house, lighting, heating, cooling systems, security monitoring and physical connectivity systems, car parks, and more. Via the Internet of Things, all on an intelligent campus shares campus resources, The campus becomes a platform for innovation.

No. of Pages : 27 No. of Claims : 8

(12) PATENT APPLICATION PUBLICATION

(21) Application No.202141022931 A

(19) INDIA

(22) Date of filing of Application :22/05/2021

(43) Publication Date : 11/06/2021

(54) Title of the invention : AUTOMATED METICULOUS MITIGATION OF TRAFFIC CONGESTION IN HANDLING UNINTERRUPTED TRAVEL OF EMERGENCY VEHICLES USING RFID AND IOT

(51) International classification	:H04L0029080000, G08G0001096500, G08B0005360000, G06Q0050100000, H04W0004800000	(71)Name of Applicant : 1)Dr.S.Vinodhkumar, Rajalakshmi Engineering College, Chennai Address of Applicant :Associate Professor Department of CSE, Rajalakshmi Engineering College, Chennai. Tamil Nadu India 2)Dr.M.Senbagavalli, Alliance University, Bangalore 3)Dr.K.Ramalakshmi, Alliance University, Bangalore 4)Dr. Hemalatha Gunasekaran 5)Mr. Venkatesan K, St. Joseph's College of Engineering, Chennai 6)Dr.S.Balakrishnan, Sri Krishna College of Engineering and Technology
(31) Priority Document No	:NA	(72)Name of Inventor : 1)Dr.S.Vinodhkumar, Rajalakshmi Engineering College, Chennai 2)Dr.M.Senbagavalli, Alliance University, Bangalore 3)Dr.K.Ramalakshmi, Alliance University, Bangalore 4)Dr. Hemalatha Gunasekaran 5)Mr. Venkatesan K, St. Joseph's College of Engineering, Chennai 6)Dr.S.Balakrishnan, Sri Krishna College of Engineering and Technology
(32) Priority Date	:NA	
(33) Name of priority country	:NA	
(86) International Application No	:NA	
Filing Date	:NA	
(87) International Publication No	: NA	
(61) Patent of Addition to Application Number	:NA	
Filing Date	:NA	
(62) Divisional to Application Number	:NA	
Filing Date	:NA	

(57) Abstract :

Traffic congestion is a growing problem everyone faces in their daily life. Traffic congestion has become the newly generated conundrum in metropolitan cities of India. Internet of Things is an environment of smart devices which are always, anywhere and anytime connected with each other while sending and receiving some data or information which can further be processed to generate meaningful analytic results. In this work, we proposed an IOT based system for providing clearance to any emergency vehicle with the aid of employing RFID technology by turning all the red lights to green on the path of the emergency vehicle. And also, we are using an IR sensor that can measure the heat of an object as well as detects the motion.

No. of Pages : 5 No. of Claims : 3

(12) PATENT APPLICATION PUBLICATION

(21) Application No.202141022951 A

(19) INDIA

(22) Date of filing of Application :23/05/2021

(43) Publication Date : 11/06/2021

(54) Title of the invention : Analyser for Online Aspect Based Sentiment Analysis in Social Media.

(51) International classification	:G06F0040300000, G06Q0050000000, G06Q0030020000, G06N0020000000, G06F0040284000	(71) Name of Applicant : 1)Dr. Mary Sowjanya Alamanda (Assistant Professor) Address of Applicant :Department of Computer Science and Systems Engineering, Andhra University College of Engineering (A)Visakhapatnam-530017, Andhra Pradesh, India. E-mail: sowmaa@yahoo.com Andhra Pradesh India 2)Ms. Srividya Kotagiri (Assistant Professor)
(31) Priority Document No	:NA	(72) Name of Inventor :
(32) Priority Date	:NA	1)Dr. Mary Sowjanya Alamanda (Assistant Professor)
(33) Name of priority country	:NA	2)Ms. Srividya Kotagiri (Assistant Professor)
(86) International Application No	:PCT//	
Filing Date	:01/01/1900	
(87) International Publication No	: NA	
(61) Patent of Addition to Application Number:	:NA	
Filing Date	:NA	
(62) Divisional to Application Number	:NA	
Filing Date	:NA	

(57) Abstract :

ABSTRACT Our Invention, Analyser for Online Aspect Based Sentiment Analysis in Social media fore-commerce websites, customer reviews have become extremely important to acquire business insights relating to merits and demerits of their products and services. The Sentiment Analysis also known as Opinion Mining has been found to be highly useful in this area. Aspect Based Sentiment Analysis (ABSA) identifies not only the sentiments of customers but also the quality of service and other related useful information. This invention also provides Sentiment Analysis of Twitter information that can be used to monitor real events such as political events or business stock-market movements. This is an automated extraction of expressions of positive, negative or neutral attitudes from text has received considerable attention from invention during the past decade. The invention is useful for growing internet users with innovative technologies using real-time online review sites, social networks and personal blogs to express their opinions. The tools provided by natural language processing and deep learning /machine learning along with other direct programming tools to work with large volumes of text, makes it possible to begin extracting sentiments from social media. This works on Twitter social media and gives the polarity which can be used in product profiling, trend analysis and forecasting. The promising results have shown that this approach can be further developed to cater business environment needs through sentiment analysis in social media.

No. of Pages : 16 No. of Claims : 7

(12) PATENT APPLICATION PUBLICATION

(21) Application No.202141022953 A

(19) INDIA

(22) Date of filing of Application :23/05/2021

(43) Publication Date : 11/06/2021

(54) Title of the invention : BUOYANCY EFFECTS ON MHD CHEMICALLY REACTING AND RADIATING CASSON FLUID PAST A PERMEABLE STRETCHING SHEET IN A POROUS MEDIUM

(51) International classification	:G06F0030200000, G06F0119080000, F04D0017160000, F01D0001360000, G06F0017100000	(71)Name of Applicant : 1)Dr. Y. HARI KRISHNA Address of Applicant :ASSISTANT PROFESSOR, DEPARTMENT OF HUMANITIES AND SCIENCE, ANURAG ENGINEERING COLLEGE, ANANTHAGIRI (V), KODAD,SURYAPET,TELANGANA-508 206 Telangana India
(31) Priority Document No	:NA	2)Dr. Y. SUNITA RANI
(32) Priority Date	:NA	3)Dr.M.V.RAMANA MURTHY
(33) Name of priority country	:NA	4)Dr. N. VIJAYA
(86) International Application No	:PCT//	5)Dr.K.JAYASANKAR
Filing Date	:01/01/1900	(72)Name of Inventor :
(87) International Publication No	: NA	1)Dr. Y. HARI KRISHNA
(61) Patent of Addition to Application Number:	:NA	2)Dr. Y. SUNITA RANI
Filing Date	:NA	3)Dr.M.V.RAMANA MURTHY
(62) Divisional to Application Number	:NA	4)Dr. N. VIJAYA
Filing Date	:NA	5)Dr.K.JAYASANKAR

(57) Abstract :

The upfront intension of this study is to explore theoretical influence of combined effects of thermal and solute buoyancy forces of Casson fluid due to porous elongated surface considering thermal radiation, heat source and chemical reaction into account for suction and injection. Basic governing equations of the flow are mathematically modeled basing upon the Casson constitutive equations. Later these were transmuted to dimensionless equations by inducing suitable similarity variables. The moderate Runge- Kutta Fehlberg shooting technique method is applied to plot the graphs. With the aid of these graphs the influence physical parameters velocity, and concentration are discussed. Non Newtonian nature of the fluid is observed from the Casson parameter evidently. Velocity of the fluid diminish for Casson parameter, magnetic parameter, permeability parameter and reverse trend is observed thermal Grashof number, solute Grashof number. profiles decrease for buoyancy forces and Prandtl number where as opposite behaviour can be observed in all remaining cases. Concentration profiles accelerate for Casson parameter, magnetic parameter, permeability parameter, and Prandtl number opposite behavior in remaining cases. Clearly it is observed that the influence of critical parameters on velocity, temperature and concentration profiles attains higher values in the case of injection and lesser values in case of suction. Impact of skin friction, Sherwood and Nusselt numbers on the flow for diverse critical parameters are exposed realistically via graphs.

No. of Pages : 27 No. of Claims : 8

(54) Title of the invention : Integration with Student Lifecycle Management with SAP (SLcM)

<p>(51) International classification</p> <p>(31) Priority Document No</p> <p>(32) Priority Date</p> <p>(33) Name of priority country</p> <p>(86) International Application No Filing Date</p> <p>(87) International Publication No</p> <p>(61) Patent of Addition to Application Number Filing Date</p> <p>(62) Divisional to Application Number Filing Date</p>	<p>:G06Q0050200000, G06F0016230000, G06Q0010100000, G09B0007020000, G09B0007000000</p> <p>:NA</p> <p>:NA</p> <p>:NA</p> <p>:PCT// :01/01/1900</p> <p>: NA</p> <p>:NA</p> <p>:NA</p> <p>:NA</p> <p>:NA</p>	<p>(71)Name of Applicant :</p> <p>1)Dr. Chethana Sridhar Address of Applicant :Dept of Computer Applications Sivananda Sarma Memorial RV College , 17, 36th cross Road,26th Main Road, 4th T Block East , Jayanagar Bengaluru, Karnataka 560041 Karnataka India</p> <p>2)Dr. T.Milton</p> <p>3)Dr. A.BALAMURUGAN</p> <p>4)Ashwini M Chalawadi</p> <p>5)D Sandhya</p> <p>6)Dr. Suresh M B</p> <p>7)Dr Dinesh H A</p> <p>8)Krupa R</p> <p>9)Dr. Manoj H M</p> <p>(72)Name of Inventor :</p> <p>1)Dr. Chethana Sridhar</p> <p>2)Dr. T.Milton</p> <p>3)Dr. A.BALAMURUGAN</p> <p>4)Ashwini M Chalawadi</p> <p>5)D Sandhya</p> <p>6)Dr. Suresh M B</p> <p>7)Dr Dinesh H A</p> <p>8)Krupa R</p> <p>9)Dr. Manoj H M</p>
--	---	---

(57) Abstract :

The Invention discloses a Novel system empowered with predictive analysis for student relationship and improvements, Various aspects in relation to studentTMs performance are considered as inputs, effects of these inputs on studentsTM performance are monitored and if any corrections are required, mentors are informed for necessary action. Improvements in the studentTMs behaviour is assured using student lifecycle management, the invention also has an alumni module which monitors the progress of student even after graduation.

No. of Pages : 11 No. of Claims : 1

(54) Title of the invention : A Novel Data Security System using Hybrid Cloud Computing

<p>(51) International classification</p> <p>(31) Priority Document No</p> <p>(32) Priority Date</p> <p>(33) Name of priority country</p> <p>(86) International Application No Filing Date</p> <p>(87) International Publication No</p> <p>(61) Patent of Addition to Application Number Filing Date</p> <p>(62) Divisional to Application Number Filing Date</p>	<p>:H04L0029080000, H04L0012260000, H04L0012240000, H04L0029060000, G06F0009500000</p> <p>:NA</p> <p>:NA</p> <p>:NA</p> <p>:PCT// :01/01/1900</p> <p>: NA</p> <p>:NA</p> <p>:NA</p> <p>:NA</p> <p>:NA</p>	<p>(71)Name of Applicant :</p> <p>1)Shaik Mohammed Rafi Address of Applicant :Assistant Professor, ECE Department, Sai Rajeswari Institute of Technology, Lingapuram, Proddatur Andhra Pradesh India</p> <p>2)Dr.Purnendu Shekhar Pandey</p> <p>3)G. Venkata Ramana Reddy</p> <p>4)Dr Varun V L</p> <p>5)Mr. Sankararao Majji</p> <p>6)Dr. Harikumar Pallathadka</p> <p>7)Dr.J Suresh Goud</p> <p>8)G.K.Jakir Hussain</p> <p>9)Dr.Manoranjan Dash</p> <p>10)Dr Balajee Maram</p> <p>11)Kaviyaraj R</p> <p>(72)Name of Inventor :</p> <p>1)Shaik Mohammed Rafi</p> <p>2)Dr.Purnendu Shekhar Pandey</p> <p>3)G. Venkata Ramana Reddy</p> <p>4)Dr Varun V L</p> <p>5)Mr. Sankararao Majji</p> <p>6)Dr. Harikumar Pallathadka</p> <p>7)Dr.J Suresh Goud</p> <p>8)G.K.Jakir Hussain</p> <p>9)Dr.Manoranjan Dash</p> <p>10)Dr Balajee Maram</p> <p>11)Kaviyaraj R</p>
--	---	---

(57) Abstract :

Abstract: Computer without network connectivity is an exception today. Earlier on everyone was using the computer to solve its individual problem. Now a day these problem related application are not available on the standalone desktop, these application are working as a client server application. In this system, server part is available at some remote machine while the client part is available at user's machine. Cloud computing is implemented using the four deployment models private cloud, public cloud, cloud hybrid and community cloud. Some of the user organization feels that the data can be misused by the company who owned the infrastructure. As a result, either they do not use the cloud services hosted on public cloud or the use only some limited services, so negate the use of cloud computing to a great extent. The solution to this is provided by the evolution of hybrid cloud. The corporate that feels security as one of the major issue in migration to cloud computing makes the use of hybrid cloud for their usage.

No. of Pages : 6 No. of Claims : 6

(12) PATENT APPLICATION PUBLICATION

(21) Application No.202141022983 A

(19) INDIA

(22) Date of filing of Application :24/05/2021

(43) Publication Date : 11/06/2021

(54) Title of the invention : A NOVEL MATERIAL FABRICATION TO DETECT BREAST CANCER USING DEEP NOVEL CLASSIFICATION MECHANISM

(51) International classification	:G06T0007000000, A61B0006000000, G06T0007440000, G16H0030400000, G06T0005100000	(71) Name of Applicant : 1)Dr. J. VENKATESH Address of Applicant :PROFESSOR, DEPARTMENT OF CSE, CHENNAI INSTITUTE OF TECHNOLOGY, SARATHY NAGAR, KUNDRATHUR, CHENNAI-69. Tamil Nadu India 2)Dr. ANITA TITUS 3)Dr. R. JANARTHANAN 4)Mrs. C.ANITHA 5)Dr. CHIRRA KESAVA REDDY 6)Mr. RANJITH S
(31) Priority Document No	:NA	(72) Name of Inventor : 1)Dr. J. VENKATESH 2)Dr. ANITA TITUS 3)Dr. R. JANARTHANAN 4)Mrs. C.ANITHA 5)Dr. CHIRRA KESAVA REDDY 6)Mr. RANJITH S
(32) Priority Date	:NA	
(33) Name of priority country	:NA	
(86) International Application No	:PCT//	
Filing Date	:01/01/1900	
(87) International Publication No	: NA	
(61) Patent of Addition to Application Number	:NA	
Filing Date	:NA	
(62) Divisional to Application Number	:NA	
Filing Date	:NA	

(57) Abstract :

Breast Cancer is a serious cause in the world, and it raises the death ratio in a drastic manner. Most of the women are suffered due to this kind of breast cancer disease, in which several kinds of literature are available regarding this breast cancer identification, but all are struck over a certain level. Lots of researchers in the industry providing different digital image processing schemes to identify Breast Cancer in a clear manner to save the lives of women but all are struck with real-world prediction scenarios. For Breast Cancer identification mammography is a well-known technique, in which it screens the breast cancer cells in a clear manner. However, based on the workload and manual expertise failures, numerous failures and wrong classification procedures reported as well. So, that a novel computer-assisted digital image processing technique and the smart tool are required to provide intelligent prediction logics to identify breast cancer in earlier conditions instead of detecting that in complex stages. In this paper, a novel Deep Learning enabled Image Processing tool is designed, called as Digital Image Processing Scheme enabled Smart Kit (DIPSK) to identify the breast cancer disease effectively in earlier stages without any human intervention.

No. of Pages : 23 No. of Claims : 7

(12) PATENT APPLICATION PUBLICATION

(21) Application No.202141022988 A

(19) INDIA

(22) Date of filing of Application :24/05/2021

(43) Publication Date : 11/06/2021

(54) Title of the invention : WORKOUT PLANS FOR COORDINATING CARDIOVASCULAR AND MUSCLOSKELETAL SESSIONS

(51) International classification	:G09B0019000000, A63B0022020000, A63B0024000000, A63B0022000000, A63B0021002000	(71)Name of Applicant : 1)Dr. S. SETHU,Assistant Professor, Department of Physical Education and Sports Address of Applicant :Assistant Professor, Department of Physical Education and Sports, Manonmaniam Sundaranar University Tirunelveli Tamilnadu India 627012 Tamil Nadu India 2)Dr. A. S. NAGESWARAN ,Director, Council for College & Curriculum Development 3)Mr. R. RAMAKRISHNAN,Research Scholar, Department of Physical Education and Sports 4)Ms. M. GANESHWARI,Research Scholar, Department of Physical Education and Sports
(31) Priority Document No	:NA	(72)Name of Inventor :
(32) Priority Date	:NA	1)Dr. S. SETHU,Assistant Professor, Department of Physical Education and Sports
(33) Name of priority country	:NA	2)Dr. A. S. NAGESWARAN ,Director, Council for College & Curriculum Development
(86) International Application No	:PCT//	3)Mr. R. RAMAKRISHNAN,Research Scholar, Department of Physical Education and Sports
Filing Date	:01/01/1900	4)Ms. M. GANESHWARI,Research Scholar, Department of Physical Education and Sports
(87) International Publication No	: NA	
(61) Patent of Addition to Application Number	:NA	
Filing Date	:NA	
(62) Divisional to Application Number	:NA	
Filing Date	:NA	

(57) Abstract :

The technique to decide exercise schedule and session for an individual vary. Based on the individual contribution and decide first-hand exercise info to decide a majority of exercise needs for the main sort of exercise plan. The principal kind of exercise depends on individual contribution and portray the exercise plan including the exercise schedule session for the first and second sorts of exercises. This also allows a more favourable interaction of the musculoskeletal system and the skeletal muscle pump, and delivers an increase in cardiac and peripheral muscle perfusion, as well. It improves physiological efficiency and decreases myocardial stress, which results in increased individual performance, health, and safety when combined with physical activity. Thus, it prevents the contracting and relaxing muscle from operating in conjunction with the pumping during any kind of physical activity.

No. of Pages : 9 No. of Claims : 5

(54) Title of the invention : FALL DETECTION AND AVOIDANCE SYSTEM FOR OLDSTERS

(51) International classification	:G08B0021040000, A61B0005000000, G16H0010600000, G08B0025010000, G06Q0050220000	(71) Name of Applicant : 1)Dr. Kalpana Murugan Address of Applicant :Professor and Head, Department of Electronics and Communication Engineering Kalasalingam Academy of Research And Education, Anand Nagar, Krishnankoil-626126, Tamil Nadu, India Tamil Nadu India
(31) Priority Document No	:NA	2)Dr. V. Muneeswaran
(32) Priority Date	:NA	3)Mr. Sadda Ashok Reddy
(33) Name of priority country	:NA	4)Mr. Rachakonda Dharmendra
(86) International Application No	:PCT//	5)Mr. Shaik Imran
Filing Date	:01/01/1900	(72) Name of Inventor :
(87) International Publication No	: NA	1)Dr. Kalpana Murugan
(61) Patent of Addition to Application Number	:NA	2)Dr. V. Muneeswaran
Filing Date	:NA	3)Mr. Sadda Ashok Reddy
(62) Divisional to Application Number	:NA	4)Mr. Rachakonda Dharmendra
Filing Date	:NA	5)Mr. Shaik Imran

(57) Abstract :

Senior individuals dealing with significant clinical issues by tumbling down. Particularly when they are living alone, old individuals will in general harm themselves from tumbling down more regularly. During the time of fall occurred, there is a need for clinical regard to be given quickly to minimize the danger of faller from getting serious. Such countless advancement has been created which some are used webcams to screen the exercises of elderly folks individuals. Besides, the expense of working and establishment is high and it is just pertinent for a home unit or restricted inside unit. Security issues have been shown up by a few clients. Current popularized gadget needed for the client to wear remote crisis transmitter on the body in type of pendant and wristband. In this strategy, because of continuous swing and development of the gadget, it shows a high bogus alert. This undertaking proposed a fall identification framework which is practical and dependable to identify fall and caution close by medical services community or family members for help and backing. For fall recognition, an accelerometer and whirligig were utilized to identify the speed increase and body slant point of the faller separately. By coupling the accelerometer with a whirligig, the exactness of the framework was improved because of decreasing in bogus positives and genuine negatives. Additionally, this wearable device requires less execution cost and gives a speedy reaction. Thus, this fall identification and ready framework has the sensitivity and specificity of 95% and 90% separately. Be that as it may, the limit of this device can't distinguish a user falling against a wall and falling end in sitting position. Suggestion for future work is to build up an intuitive presentation which empowers users to enter close by medical services place and relative's phone number.

No. of Pages : 7 No. of Claims : 4

(12) PATENT APPLICATION PUBLICATION

(21) Application No.202141023019 A

(19) INDIA

(22) Date of filing of Application :24/05/2021

(43) Publication Date : 11/06/2021

(54) Title of the invention : SMART IRRIGATION SYSTEM USING INDUSTRIAL INTERNET OF THINGS (IIOT)

<p>(51) International classification</p> <p>(31) Priority Document No</p> <p>(32) Priority Date</p> <p>(33) Name of priority country</p> <p>(86) International Application No Filing Date</p> <p>(87) International Publication No</p> <p>(61) Patent of Addition to Application Number Filing Date</p> <p>(62) Divisional to Application Number Filing Date</p>	<p>:A01G0025160000, A01C0023040000, A01G0025060000, G05B0015020000, A01G0027020000</p> <p>:NA</p> <p>:NA</p> <p>:NA</p> <p>:PCT// :01/01/1900</p> <p>: NA</p> <p>:NA</p> <p>:NA</p> <p>:NA</p>	<p>(71)Name of Applicant :</p> <p>1)MR. S. SRINIVASAN Address of Applicant :ASSISTANT PROFESSOR, DEPARTMENT OF AGRICULTURE ENGINEERING, NEHRU INSTITUTE OF TECHNOLOGY, JAWAHAR GARDENS • , KALIAPURAM, THIRUMALAYAMPALAYAM (PO), COIMBATORE- 641105, TAMILNADU, INDIA E-MAIL: srinitech2k@gmail.com Tamil Nadu India</p> <p>2)MRS. GULJA S NAIR</p> <p>3)MR. R. BHARATHIKANNA</p> <p>4)MR. A. C. RAMKUMAR</p> <p>5)MR. N. MOHAMMED RAFFIC</p> <p>6)MR. A.S. RAJAN</p> <p>7)MR. S. RADHAKRISHNAN</p> <p>8)MR. P. SIVA</p> <p>9)MR. A. BALTHILAK</p> <p>10)DR. C. MADHUSUDAN NAYAK</p> <p>11)Mr.N.Nagarajan</p> <p>(72)Name of Inventor :</p> <p>1)MR. S. SRINIVASAN</p> <p>2)MRS. GULJA S NAIR</p> <p>3)MR. R. BHARATHIKANNA</p> <p>4)MR. A. C. RAMKUMAR</p> <p>5)MR. N. MOHAMMED RAFFIC</p> <p>6)MR. A.S. RAJAN</p> <p>7)MR. S. RADHAKRISHNAN</p> <p>8)MR. P. SIVA</p> <p>9)MR. A. BALTHILAK</p> <p>10)DR. C. MADHUSUDAN NAYAK</p>
--	--	---

(57) Abstract :

Irrigation is the process of applying water to the crops artificially to fulfill their water requirements. The frequency, rate, amount and time of irrigation are different for different crops and also vary according to the types of soil and seasons. In traditional methods efficiency is poor because of the uneven distribution of water. Also, the chances of water loss are very high. The modern method Sprinkler system and Drip system helps in the proper way of water usage. Irrigation should be optimum because even over-irrigation can spoil the crop production. Excess water leads to waterlogging, hinder germination, increased salt concentration and uprooting because roots can't withstand standing water. Thus the proper irrigation method is to be used for the best cultivation. Sprinkler and drip irrigation system lags in controlling excess water and nutritional level of soil level. These system consumes excessive energy (pump should be operated continuously), does not fulfill water requirements of crops based on season. In this invention, irrigation system is designed such a way that crops get exact water and nutrients at specific location immediately when shortage occurs. Irrigation system takes care of seasonal changes, weather conditions, age of crop and can be monitored and operated remotely.

No. of Pages : 9 No. of Claims : 4

(12) PATENT APPLICATION PUBLICATION

(21) Application No.202141023148 A

(19) INDIA

(22) Date of filing of Application :24/05/2021

(43) Publication Date : 11/06/2021

(54) Title of the invention : Smart Socket- An Technology Enabler To Prevent Electrical Hazards in Household Applications

(51) International classification	:H02J0007000000, H01R0013660000, H04L0029080000, H02J0007020000, A61K0031410000	(71)Name of Applicant : 1)Dr. V. Muneeswaran Address of Applicant :Assistant Professor, Department of Electronics and Communication Engineering Kalasalingam Academy of Research And Education, Anand Nagar, Krishnankoil-626126, Tamil Nadu, India Tamil Nadu India 2)Dr. Kalpana Murugan 3)Mr. Mangala Madhu 4)Mr. G. Siddu Sai Shareef 5)Mr. Guttapalli Pavan Kumar 6)Mr. Gudipati Harsha Vardhan
(31) Priority Document No	:NA	(72)Name of Inventor : 1)Dr. V. Muneeswaran 2)Dr. Kalpana Murugan 3)Mr. Mangala Madhu 4)Mr. G. Siddu Sai Shareef 5)Mr. Guttapalli Pavan Kumar 6)Mr. Gudipati Harsha Vardhan
(32) Priority Date	:NA	
(33) Name of priority country	:NA	
(86) International Application No	:PCT//	
Filing Date	:01/01/1900	
(87) International Publication No	: NA	
(61) Patent of Addition to Application Number	:NA	
Filing Date	:NA	
(62) Divisional to Application Number	:NA	
Filing Date	:NA	

(57) Abstract :

Power is a crucial electrical amount and nowadays everything in an exceedingly and also world depends on having the ability to stay them running. Because of industrial growth & urbanization power may be a basic would like of our life. Within the gifted situation of electricity conservation, associated degree of automatic charger is provided capable of charging many removable batteries comprising a block for activity power from the mains and several other battery charging modules. A while some have a tendency to simply place the charging and could not monitor the mobile when obtaining 100% charging ,in order to overcame this downside a brand new methodology referred to as smart socket • it ought to conserve the ability and avoid the wastage of electricity when obtaining 100% of charge.

No. of Pages : 6 No. of Claims : 4

(12) PATENT APPLICATION PUBLICATION

(21) Application No.202141023154 A

(19) INDIA

(22) Date of filing of Application :24/05/2021

(43) Publication Date : 11/06/2021

(54) Title of the invention : Investigation on PV Fed Hybrid Electric Vehicles with Various Power Electronic Circuits

<p>(51) International classification :B60W0010080000, B60L0058100000, B60L0058120000, B60L0050600000, B60L0015200000</p> <p>(31) Priority Document No :NA (32) Priority Date :NA (33) Name of priority country :NA (86) International Application No :PCT// Filing Date :01/01/1900 (87) International Publication No : NA (61) Patent of Addition to Application Number :NA Filing Date :NA (62) Divisional to Application Number :NA Filing Date :NA</p>	<p>(71)Name of Applicant : 1)Srinivas Cheera, Research Scholar / Department of EEE, University College of Engineering, Osmania University Address of Applicant :University College of Engineering, Osmania University, Hyderabad, Telangana- 500007 Telangana India 2)B. Srikanth Goud, Assistant Professor / Department of EEE, Anurag College of Engineering 3)Seelam VSV Prabhu Deva Kumar, Assistant Researcher /R&D Center, JoongAng Control Co., Ltd 4)Dr.CH.Naga Sai kalyan,Assistant professor/Department of EEE, Vasireddy Venkatadri Institute of Technology. 5)Dr. K.V.G Raghavendra , Sustainable Energies Research and Project Consultant/Nextgen Management consultancy 6)Kiran Kommireddy,Assistant Engineer / Mechanical Maintenance 7)A.N Venkateswarlu, Associate Professor/Department of EEE, Vignan's Lara Institute of Technology and Science 8)Dr. Gaurav Srivastava,Assistant professor/Department of EEE, Poornima College of Engineering</p> <p>(72)Name of Inventor : 1)Srinivas Cheera, Research Scholar / Department of EEE, University College of Engineering, Osmania University 2)B. Srikanth Goud, Assistant Professor / Department of EEE, Anurag College of Engineering 3)Seelam VSV Prabhu Deva Kumar, Assistant Researcher /R&D Center, JoongAng Control Co., Ltd 4)Dr.CH.Naga Sai kalyan,Assistant professor/Department of EEE, Vasireddy Venkatadri Institute of Technology. 5)Dr. K.V.G Raghavendra , Sustainable Energies Research and Project Consultant/Nextgen Management consultancy 6)Kiran Kommireddy,Assistant Engineer / Mechanical Maintenance 7)A.N Venkateswarlu, Associate Professor/Department of EEE, Vignan's Lara Institute of Technology and Science 8)Dr. Gaurav Srivastava,Assistant professor/Department of EEE, Poornima College of Engineering</p>
--	--

(57) Abstract :

Abstract The detailed investigation on PV fed hybrid electric vehicles with energy storage system. Significant growth of sustainable energy system leads to development of transportation sector with clean energy sources for better environment condition. Recent configuration in hybrid vehicle system along with merits and demerits further, battery management system and various power converter topologies for electric vehicle system are presented for enhancing the performance and reliability of the vehicles. Various operating modes are identified with various electrical parameters and presented for efficient power conversion.

No. of Pages : 17 No. of Claims : 5

(12) PATENT APPLICATION PUBLICATION

(21) Application No.202141023187 A

(19) INDIA

(22) Date of filing of Application :24/05/2021

(43) Publication Date : 11/06/2021

(54) Title of the invention : A PROBIOTIC COMPOSITION FOR MAKING BEAD FOR POULTRY

(51) International classification	:A61K0035744000, A23P0010300000, A23K0010180000, A61K0035742000, A61K0009500000	(71) Name of Applicant : 1)TAMILNADU VETERINARY AND ANIMAL SCIENCES UNIVERSITY Address of Applicant :Tamil Nadu Veterinary and Animal Sciences University, Madhavaram Milk colony, Chennai Tamil Nadu India
(31) Priority Document No	:NA	(72) Name of Inventor :
(32) Priority Date	:NA	1)Mr.K. ARULKUMAR
(33) Name of priority country	:NA	2)Dr.R.P.ARAVINDHBABU
(86) International Application No	:PCT//	3)Dr.S. THIYAGARAJAN
Filing Date	:01/01/1900	4)Dr.P. AZHAHANAMBI
(87) International Publication No	: NA	5)Dr.T.M.A. SENTHILKUMAR
(61) Patent of Addition to Application Number	:NA	6)Dr.G. DHINAKAR RAJ
Filing Date	:NA	
(62) Divisional to Application Number	:NA	
Filing Date	:NA	

(57) Abstract :

A probiotic composition for making bead for poultry relates to a probiotic composition with the core comprising one or more probiotic microorganisms selected from Bacillus subtilis, Bacillus firmus, Enterococcus faecium, Enterococcus faecalis, Saccharomyces cerevisiae or mixture thereof ; an enteric coating layer encapsulating the core; a cross linking film for cross linking the enteric coating layer with the cross linking film for cross linking the enteric coating layer with the cross linking film to form a protective layer. The composition is capable of bacterial cell viability, bacterial cell stability, particle size uniformity, intestinal targeting and long shell life.

No. of Pages : 38 No. of Claims : 17

(12) PATENT APPLICATION PUBLICATION

(21) Application No.202141023192 A

(19) INDIA

(22) Date of filing of Application :25/05/2021

(43) Publication Date : 11/06/2021

(54) Title of the invention : DESIGN AND IMPLEMENTATION OF EFFICIENT ALGORITHMS FOR CONTENT BASED IMAGE RETRIEVAL USING LOCAL PATTERNS BASED FEATURE DESCRIPTORS

(51) International classification	:G06K0009460000, G06F0016583000, G06K0009620000, G06T0007900000, G09G0003340000	(71) Name of Applicant : 1)Dr. Bhaskar Reddy P.V. Address of Applicant :Professor, School of Computing and Information Technology, REVA University, Bengaluru, India Karnataka India 2)Dr. M Prabaker 3)Dr. J Manoranjini 4)Dr. J Sasi Bhanu 5)Y J SUDHA RANI 6)ANIL KUMAR SAGGU RENUKA
(31) Priority Document No	:NA	(72) Name of Inventor : 1)Dr. Bhaskar Reddy P.V. 2)Dr. M Prabaker 3)Dr. J Manoranjini 4)Dr. J Sasi Bhanu 5)Y J SUDHA RANI 6)ANIL KUMAR SAGGU RENUKA
(32) Priority Date	:NA	
(33) Name of priority country	:NA	
(86) International Application No	:PCT//	
Filing Date	:01/01/1900	
(87) International Publication No	: NA	
(61) Patent of Addition to Application Number	:NA	
Filing Date	:NA	
(62) Divisional to Application Number	:NA	
Filing Date	:NA	

(57) Abstract :

A new image retrieval algorithm by integrating color and texture features. In the present work to improve retrieval performance multiple features are presented i.e. Directional Binary Wavelet Patterns (DBWP) based texture features combined with color feature such as HSV color histogram. For color feature, first the RGB image is converted to HSV image, and then histograms are constructed from HSV spaces. For texture feature, an 8-bit grayscale image is divided into eight binary bit-planes, and then Binary Wavelet Transform (BWT) on each bitplane to extract the multi-resolution binary images. The Local Binary Pattern (LBP) features are extracted from the resultant BWT sub-bands. A large MIT VisTex database and Corel database images are used to check the retrieval performance. Experimental results have shown that the performance of the CBIR system using color and texture features is superior when compared to CBIR algorithm using only texture features or CBIR algorithm using color features alone

No. of Pages : 23 No. of Claims : 2

(54) Title of the invention : E-HEALTH SYSTEM WITH CLINICAL DOCUMENT ARCHITECTURE (CDA)

<p>(51) International classification :G16H0010200000, G16H0010600000, G06Q0050220000, G16H0050200000, H04L0029080000</p> <p>(31) Priority Document No :NA (32) Priority Date :NA (33) Name of priority country :NA (86) International Application No :PCT// Filing Date :01/01/1900 (87) International Publication No : NA (61) Patent of Addition to Application Number :NA Filing Date :NA (62) Divisional to Application Number :NA Filing Date :NA</p>	<p>(71)Name of Applicant : 1)Dr. R. SARAVANAN Address of Applicant :ASSOCIATE PROFESSOR DEPARTMENT OF INFORMATION TECHNOLOGY CHENNAI INSTITUTE OF TECHNOLOGY SARATHY NAGAR, PUDUPEDU VILLAGE, SH-113, KUNDRATHURSRIPERUMBUDUR MAIN ROAD, KUNDRATHUR, CHENNAI, KANCHIPURAM DISTRICT, TAMIL NADU, INDIA. PIN 600 069. Tamil Nadu India</p> <p>2)Dr. R. JANARTHANAN 3)Dr. B. SUNDARAMBAL 4)Dr. K. SOMASUNDARAM 5)Dr. K. SURESH 6)Dr. K. ANAND</p> <p>(72)Name of Inventor : 1)Dr. R. SARAVANAN 2)Dr. R. JANARTHANAN 3)Dr. B. SUNDARAMBAL 4)Dr. K. SOMASUNDARAM 5)Dr. K. SURESH 6)Dr. K. ANAND</p>
--	--

(57) Abstract :

ABSTRACT E-HEALTH SYSTEM WITH CLINICAL DOCUMENT ARCHITECTURE (CDA) E-healthcare systems have been progressively working with ailment observing, sickness demonstrating and early intercession, and proof based clinical therapy by clinical content mining and picture include extraction. Proposed framework screens the ailment and gives clinical treatment through our web application. To safely share the Public Health Report (PHR) data in cloud computing, a patient partitions his PHR data M into two sections: individual data m1 that may contain the patient's name, government managed retirement number, phone number, personal residence, and so on The clinical record m2 doesn't contain delicate individual data, for example, clinical trial results, treatment conventions, and activity notes. The layered admittance structures present in the proposed framework are coordinated into a solitary access construction, and afterward, the progressive documents are scrambled with the incorporated admittance structure. In this way, both code text stockpiling and time cost of encryption is saved in the proposed framework, for cloud storage we will utilize Cloud-Me. An effective record pecking order characteristic based encryption conspire is utilized in the cloud computing. Encryption innovation is utilized to tackle the difficult issue of the got information partaking in Health care framework (HES) to address these issues HES structure is planned that gathers clinical information from Wireless Body Area Networks(WBANs). The model execution of HES is investigated to check the attainability, proposed framework faces numerous difficulties which incorporates the data security and protection conservation. Thus, it will diminish the time and cost of the encryption and furthermore lessens the cloud storage by utilizing the cloud-Me.

No. of Pages : 27 No. of Claims : 9

(12) PATENT APPLICATION PUBLICATION

(21) Application No.202141023368 A

(19) INDIA

(22) Date of filing of Application :25/05/2021

(43) Publication Date : 11/06/2021

(54) Title of the invention : A compact IOT based Indoor air monitoring system

(51) International classification	:C12N0005070000, E04H0001120000, B01D0053620000, A61L0009160000, G08B0027000000	(71)Name of Applicant : 1)Dr. Pramod M S Address of Applicant :Designation: Associate Professor Department: Electronics and Communication Engineering PES University, Electronic City Campus, Hosur Rd, Bengaluru, Karnataka 560100 Karnataka India 2)Sreelakshmi T K 3)Dr. Nitin Jagannath Patil 4)Sathisha B M 5)Dr. Vasanthakumar G U 6)Yogitha R 7)Sadashiva V. Chakrasali 8)Dr. Sunitha Y N
(31) Priority Document No	:NA	(72)Name of Inventor : 1)Dr. Pramod M S 2)Sreelakshmi T K 3)Dr. Nitin Jagannath Patil 4)Sathisha B M 5)Dr. Vasanthakumar G U 6)Yogitha R 7)Sadashiva V. Chakrasali 8)Dr. Sunitha Y N
(32) Priority Date	:NA	
(33) Name of priority country	:NA	
(86) International Application No	:PCT//	
Filing Date	:01/01/1900	
(87) International Publication No	: NA	
(61) Patent of Addition to Application	:NA	
Number	:NA	
Filing Date	:NA	
(62) Divisional to Application Number	:NA	
Filing Date	:NA	

(57) Abstract :

The Internet of Things has been demonstrating its capability to take care of issues where presence of data can contribute enormous to an answer or become the actual arrangement. An entire reach of associated things, conversing with one another can convey handled data to individuals that would help them in showing up at significant decisions about unique, yet significant components. One such factor is air and its quality. In a populace thick world and taking a gander at the patterns in the quantity of causalities due to messy air it is profoundly significant that individuals are educated regarding the nature of air that they relax. Indoor air quality is a very significant factor to be judged and dissected and the requirement for an compelling answer for do so is unavoidable. With air purifiers being ready to clean the air inside, there is no space for clients to check the consistency of such an interaction and no arrangement to contemplate the long time conduct of air they get to breath. The proposed system that would make clients study the air around them both continuously and throughout some undefined time frame would be introduced. An assortment of contamination focuses would be estimated and educated to clients, cautioning clients in this manner of probably the most destructive contamination focuses.

No. of Pages : 11 No. of Claims : 2

(12) PATENT APPLICATION PUBLICATION

(21) Application No.202141023369 A

(19) INDIA

(22) Date of filing of Application :25/05/2021

(43) Publication Date : 11/06/2021

(54) Title of the invention : Automated ayurvedic device for Kayasheka- Pizzicchil therapeutic procedure

(51) International classification	:A61M0021000000, G01N0035100000, E03C0001040000, A61H0001000000, G01N0035000000	(71) Name of Applicant : 1)Dr H Pampanna Gouda Address of Applicant :#107/12 Near Kalmat, Reddy Street, Bellary-583101 Karnataka India 2)Dr Seema MB 3)Hirehal Neha 4)Hirehal Nayan
(31) Priority Document No	:NA	(72) Name of Inventor :
(32) Priority Date	:NA	1)Dr H Pampanna Gouda
(33) Name of priority country	:NA	2)Dr Seema MB
(86) International Application No	:PCT//	3)Hirehal Neha
Filing Date	:01/01/1900	4)Hirehal Nayan
(87) International Publication No	: NA	
(61) Patent of Addition to Application Number	:NA	
Filing Date	:NA	
(62) Divisional to Application Number	:NA	
Filing Date	:NA	

(57) Abstract :

Apparatus and method for automated ayurvedic therapeutic device for Kayasheka(pizzicchil) treatment to a human body, the said automated device further comprises of a plurality of dispensing arm which dispenses the medicated liquids on the human body in a rain shower method and the dispensing arm is supported by a ceiling above the dispensing the arm, the medicated liquids is heated to predetermine time and temperature with the help of the main central unit which further consists of heating panel, sensors. This apparatus is fixed to a conventional droni system in which the human body is placed, the medicated liquid is dispensed though the rain shower system which is achieved by the to and fro moment of the dispensing arm.

No. of Pages : 29 No. of Claims : 8

(12) PATENT APPLICATION PUBLICATION

(21) Application No.202141023375 A

(19) INDIA

(22) Date of filing of Application :26/05/2021

(43) Publication Date : 11/06/2021

(54) Title of the invention : A fibre material with moisture retention capacity with thermal tolerance and a method for manufacture of the same

(51) International classification	:D01D0005000000, D01F0001100000, A41D0013005000, A42B0001000000, D06M0011470000	(71) Name of Applicant : 1)SRM University - AP Address of Applicant :SRM University AP, Neerukonda, Mangalagiri, Guntur District, Andhra Pradesh 522502 Andhra Pradesh India
(31) Priority Document No	:NA	(72) Name of Inventor :
(32) Priority Date	:NA	1)Bhuvaneswari Sreelekha
(33) Name of priority country	:NA	2)Sabyasachi Mukhopadhyay
(86) International Application No	:PCT//	
Filing Date	:01/01/1900	
(87) International Publication No	: NA	
(61) Patent of Addition to Application Number	:NA	
Filing Date	:NA	
(62) Divisional to Application Number	:NA	
Filing Date	:NA	

(57) Abstract :

A durable electrospun fiber with thermal tolerance. The Saharan silver ants display a property with their body hair design and mechanism of their survival under high temperatures in the Saharan desert. The nano-structured fiber surface will reflect the heat by mimicking the body hairs of these ants. In addition to it, the supporting core material of the electrospun fiber, which would not make any difference with the other blending material of core; but as an advantage, it stores water droplets similar to a clay pot, which provides a cooling platform at warm environments owing to water evaporation. The developed fabric will provide a cooling effect throughout with less maintenance, and require just a few minutes to load water by emerging in water tank or spraying water on it. These electrospun fibers could be widely used for covering thermal sensitive appliances which need a regular temperature-controlled environment.

No. of Pages : 11 No. of Claims : 3

(12) PATENT APPLICATION PUBLICATION

(21) Application No.202141023385 A

(19) INDIA

(22) Date of filing of Application :26/05/2021

(43) Publication Date : 11/06/2021

(54) Title of the invention : HIGH POWER LITHIUM ION CELLS AND A METHOD FOR PROCESSING THE SAME

(51) International classification	:H01M0010052500, H01M0010440000, H01M0004525000, H01M0010480000, H01M0010058000	(71)Name of Applicant : 1)Indian Space Research Organisation Address of Applicant :Department of Space, Antariksh Bhavan, New BEL Road, Bangalore 560094 Karnataka India
(31) Priority Document No	:NA	(72)Name of Inventor :
(32) Priority Date	:NA	1)Smt. TD Mercy
(33) Name of priority country	:NA	2)Dr. S Aravamuthan
(86) International Application No	:PCT//	3)Shri. PS VijayaKumar
Filing Date	:01/01/1900	4)Smt. Aiswarya Samridh
(87) International Publication No	: NA	5)Dr. Bibin John
(61) Patent of Addition to Application	:NA	6)Shri. M Arjun Raj
Number	:NA	7)Shri Deepak Srivastava
Filing Date	:NA	8)Shri. MD Jamal Nawaz Ansari
(62) Divisional to Application Number	:NA	9)Shri. K Vijayakumar
Filing Date	:NA	10)Shri. V Vinod
		11)Shri. S Padmakumar
		12)Shri. MR Rajesh Kumar
		13)Shri. K Sunil
		14)Shri. KT Saju
		15)Shri. P Jineesh
		16)Shri. K Bineeshlal

(57) Abstract :

The present invention relates to an elliptic cylindrical high-power lithium-ion cell based on Lithium Nickel Cobalt Aluminium Oxide cathode & graphite anode and a method for processing the same. The lithium-ion cell can exhibit discharge rate capability up to 15C in continuous discharge and 50C in pulse discharge with a lower internal resistance. The cell has lower internal resistance (3-4 mΩ (AC impedance at 1 kHz) for a typical 4 Ah cell). The high-power capability is achieved by the combined effect of lower loading level of positive and negative electrodes, use of conducting agents for positive and negative electrodes, use of electrolytes with high ionic conductivity and by adopting laser beam welding for intermediate tab to stack welding. The provided cell is stable against external physical impact such as vibration, shock, falling, and the like, and also provide a method for processing such a cell. Figure-1a

No. of Pages : 26 No. of Claims : 30

(12) PATENT APPLICATION PUBLICATION

(21) Application No.202141023459 A

(19) INDIA

(22) Date of filing of Application :26/05/2021

(43) Publication Date : 11/06/2021

(54) Title of the invention : NOVEL SYNTHESIS AND DFT CALCULATIONS OF 3-PHENYL-2-(1H-TETRAZOL-5-YL)ACRYLAMIDES UNDER CATALYST-FREE, ONE-POT CASCADE REACTION

(51) International classification	:C07D0257040000, G16C0010000000, G16C0020100000, C07D0307680000, H01L0051000000	(71)Name of Applicant : 1)JYOTHIS DEVASIA Address of Applicant :Department of Chemistry, CHRIST (Deemed to be University), Bengaluru, Karnataka - 560029, India. Karnataka India 2)AATIKA NIZAM 3)SAMPATH CHINNAM 4)SONAM SHAKYA 5)KAVITA KHATANA 6)ARIN NATANIA S 7)HARITHA ARNIPALLI 8)AMRUTHA DAS OLLASERRY
(31) Priority Document No	:NA	(72)Name of Inventor :
(32) Priority Date	:NA	1)JYOTHIS DEVASIA
(33) Name of priority country	:NA	2)AATIKA NIZAM
(86) International Application No	:PCT//	3)SAMPATH CHINNAM
Filing Date	:01/01/1900	4)SONAM SHAKYA
(87) International Publication No	: NA	5)KAVITA KHATANA
(61) Patent of Addition to Application	:NA	6)ARIN NATANIA S
Number	:NA	7)HARITHA ARNIPALLI
Filing Date	:NA	8)AMRUTHA DAS OLLASERRY
(62) Divisional to Application Number	:NA	
Filing Date	:NA	

(57) Abstract :

The present invention offers a novel method for the synthesis of 3-phenyl-2-(1H-tetrazol-5-yl)acrylamides 4(a-g) under catalyst-free conditions. All the reactions were carried out in an one-pot cascade process starting with various aromatic/heteroaryl aldehydes, 2-cyanoacetamide and sodium azide at 110 oC using dimethylformamide (DMF) as a solvent. In addition, the reaction conditions were screened for optimization conditions towards solvent, catalyst, temperature and equivalence of sodium azide. DFT studies using B3LYP/6-311G basis set level of theory were used to provide comparable theoretical data along with MEP map and electronic energy gap of HOMO+LUMO. Experimental data was justified with DFT using B-3LYP/ 6-311G (basis set) level of theoretical calculations to obtain chemical, structural, spectroscopic, thermodynamic and vibrational phenomena of all the novel synthesized tetrazole analogues. The invention delivers a facile and efficient synthetic protocol, and it has numerous advantages such as low cost of starting substrates, significant improvement of reaction times, less impurities, selective, and avoiding tedious work-up procedures.

No. of Pages : 19 No. of Claims : 12

(54) Title of the invention : A SYSTEM BASED ON MACHINE LEARNING AND ARTIFICIAL INTELLIGENCE MODULES FOR PROVIDING IOT NETWORK CONFIGURATION THROUGH USER VOICE AND GESTURE AND METHOD THEREOF

<p>(51) International classification</p> <p>(31) Priority Document No</p> <p>(32) Priority Date</p> <p>(33) Name of priority country</p> <p>(86) International Application No Filing Date</p> <p>(87) International Publication No</p> <p>(61) Patent of Addition to Application Number Filing Date</p> <p>(62) Divisional to Application Number Filing Date</p>	<p>:H04L0029080000, G06N0020000000, G06F0003160000, G10L0015220000, G06N0003080000</p> <p>:NA</p> <p>:NA</p> <p>:NA</p> <p>:PCT// :01/01/1900</p> <p>: NA</p> <p>:NA :NA</p> <p>:NA :NA</p>	<p>(71)Name of Applicant :</p> <p>1)Mr.S.Jaya Prakash Address of Applicant :Associate Professor, Department of CSE, Idhaya Engineering College for Women, Chinnasalem, Kallakurichi District, Tamil Nadu, India. Pin Code:606201 Tamil Nadu India</p> <p>2)Mr.Venkata Subbaiah Desanamukula</p> <p>3)Dr.Mandadi Srinivas</p> <p>4)Dr.Kandunuri Ramakrishna</p> <p>5)Mr.U.Rakesh</p> <p>6)Mrs.N.L.Aravinda</p> <p>7)Dr.Sushma Jaiswal</p> <p>8)Mr.Tarun Jaiswal</p> <p>9)Dr.A.V.Sudhakara Reddy</p> <p>10)Mr.N.Naveen Sagar</p> <p>(72)Name of Inventor :</p> <p>1)Mr.S.Jaya Prakash</p> <p>2)Mr.Venkata Subbaiah Desanamukula</p> <p>3)Dr.Mandadi Srinivas</p> <p>4)Dr.Kandunuri Ramakrishna</p> <p>5)Mr.U.Rakesh</p> <p>6)Mrs.N.L.Aravinda</p> <p>7)Dr.Sushma Jaiswal</p> <p>8)Mr.Tarun Jaiswal</p> <p>9)Dr.A.V.Sudhakara Reddy</p> <p>10)Mr.N.Naveen Sagar</p>
--	---	--

(57) Abstract :

ABSTRACT A SYSTEM BASED ON MACHINE LEARNING AND ARTIFICIAL INTELLIGENCE MODULES FOR PROVIDING IOT NETWORK CONFIGURATION THROUGH USER VOICE AND GESTURE AND METHOD THEREOF [033]

The present invention discloses a system based on Machine Learning and Artificial Intelligence modules for providing IoT network configuration through user voice and gesture and method thereof. The system includes, but not limited to, an image capturing device for receiving the live gesture of the user for defining the network configuration between the IoT devices; an audio recording device for receiving the voice command of the user for defining the network configuration between the IoT devices; a plurality of Machine Learning and Artificial Intelligence modules for evaluating the provided weight function for the each of the data input through the image capturing device and the audio recording device; and a processing unit in an IoT environment designed to process and perform mapping of a plurality of weight functions using Natural Language Processing Techniques for audio based input and image processing techniques for image based input. Accompanied Drawing [FIG. 1]

No. of Pages : 23 No. of Claims : 8

(12) PATENT APPLICATION PUBLICATION

(21) Application No.202141023567 A

(19) INDIA

(22) Date of filing of Application :27/05/2021

(43) Publication Date : 11/06/2021

(54) Title of the invention : A Novel System for Controlling Employees Attrition Rate

(51) International classification	:G06Q0010060000, G06Q0010100000, G06Q0040020000, G07C0001100000, B03B0009000000	(71)Name of Applicant : 1)Dr. Suresh M B Address of Applicant :Designation: Professor and Head Department: Information Science & Engg. Institution address: East West Institute of Technology, Bengaluru Email id: sureshresearch45@gmail.com Mobile No: 6362371359 Karnataka India 2)Prof Veena Ganesh 3)Gouri S Katageri 4)Dr Dinesh H A 5)D Sandhya 6)Dr. Manoj H M 7)Krupa R 8)Dr. Chethana Sridhar
(31) Priority Document No	:NA	(72)Name of Inventor : 1)Dr. Suresh M B 2)Prof Veena Ganesh 3)Gouri S Katageri 4)Dr Dinesh H A 5)D Sandhya 6)Dr. Manoj H M 7)Krupa R 8)Dr. Chethana Sridhar
(32) Priority Date	:NA	
(33) Name of priority country	:NA	
(86) International Application No	:PCT//	
Filing Date	:01/01/1900	
(87) International Publication No	: NA	
(61) Patent of Addition to Application Number	:NA	
Filing Date	:NA	
(62) Divisional to Application Number	:NA	
Filing Date	:NA	

(57) Abstract :

Title of Invention: A Novel System for Controlling Employees Attrition Rate Field of Invention: Management using Computer Application ABSTRACT An attrition alarm and control system warns an employer when an employee is about to leave. The employee is assigned to a specific turnover group. The discrete turnover group is determined by employee satisfaction activities. Employee satisfaction behaviour can be characterised according to its type. Portal logic run by the attrition alarm and control system generates employee team attrition risk reports. The gateway logic generates project team attrition risk reports from employee team attrition risk reports. The attrition alert and control system's reporting logic sends separate attrition group, employee satisfaction behaviour, employee team attrition risk reports, and project team attrition risk reports over an approved link over a communication interface.

No. of Pages : 11 No. of Claims : 1

(54) Title of the invention : Kannada Text Detection and Recognition from Natural Scene Images using AksharaNet CNN Model

(51) International classification	:G06K0009000000, G06K0009620000, G06N0003040000, G06N0003080000, G06K0009320000	(71)Name of Applicant : 1)Shahzia Siddiqua Address of Applicant :REVA UNIVERSITY Rukmini Knowledge Park, Kattigenahalli, Yelahanka, Bangalore Karnataka India
(31) Priority Document No	:NA	2)Sunilkumar S Manvi
(32) Priority Date	:NA	3)Naveena C
(33) Name of priority country	:NA	(72)Name of Inventor :
(86) International Application No	:PCT// /	1)Shahzia Siddiqua
Filing Date	:01/01/1900	2)Naveena C
(87) International Publication No	: NA	3)Sunilkumar S Manvi
(61) Patent of Addition to Application Number	:NA	
Filing Date	:NA	
(62) Divisional to Application Number	:NA	
Filing Date	:NA	

(57) Abstract :

With the ascent in deep learning, computer vision problems have taken center stage among the research community. As an important research area in computer vision, image text detection and recognition has been inevitably influenced by this wave of revolution. For content-based indexing and retrieval applications, text characters embedded in images are a rich source of information. Owing to their different shapes, grayscale values, and dynamic backgrounds, these text characters in scene images are difficult to detect and classify. The complexity increases when the text involved is a vernacular language like Kannada. Despite advances in deep learning neural networks (DLNN), there is a dearth of fast and effective models to classify scene text images and the availability of a large-scale Kannada scene character dataset to train them. Text recognition from natural images is an extremely complex task and entails not just detecting the text but also locating it inside the image by producing the co-ordinates of a bounding box that holds the text. Here, five claim defining inventions are proposed, (i) Kannada Scene Individual Character (KSIC) dataset which is ground-up curated (ii) AksharaNet, a graphical processing unit (GPU) accelerated modified convolution neural network architecture consisting of linearly inverted depth-wise separable convolutions, (iii) leveraging Transfer Learning in Deep Learning for detecting and recognizing text in scene images motivated by the object detection algorithm, You Only Look Once (YOLO), (iv) Early stopping decisions at 25% and 50% epoch with good and bad accuracies for complex and light models and (v) Useful findings concerning learning rate drop factor and its ideal application period. The YOLO algorithm creates a bounding box around a detected object and includes the box's location information as well. Taking cue from this, AksharaNet, a convolution neural network (CNN) based classification model with YOLO algorithm implemented was trained on the KSIC dataset. A single reference scene image is split into 19x19 grids and the pre-trained network acts as a feature extractor and localizer. It detects text by predicting a class, builds a bounding box, and specifies text location and their respective class names which are then indexed in dictionary. From results, the KSIC dataset generated consists of 46,800 images which are classified into 468 classes, each with 100 samples for training the CNN. It is observed that AksharaNet outperforms four other well-established models by 1.5% on CPU and 1.9% on GPU. The results can be directly attributed to the quality of the developed KSIC dataset. Testing the efficacy of this network using the YOLO algorithm on the same dataset and using Transfer learning resulted in an accuracy of 90.17% and test area under the curve (AUC) of 0.932. Comparing this proposed model with existing models, it is observed that pre-trained AksharaNet with YOLO implementation returns the best precision, recall and F1-scores of 88%, 90% and 93.83% respectively, which is greater than 8%, 4% and 5% on an average compared to other models. And based on early stopping decisions and learning rate drop factor findings suggestions are tabulated for various scenarios. Therefore, results prove that (i) The KSIC dataset is large and robust to train the designed CNN, (ii) AksharaNet outperforms some of the leading CNNs being used in Deep Learning, (iii) the early stopping decisions and learning rate drop factor identified are key parameters for improved CNN performance and (iv) YOLO can be extended to other areas beyond just object detection with Transfer learning an efficient and effective deep learning technique for these class of computer vision problems.

No. of Pages : 17 No. of Claims : 4

(12) PATENT APPLICATION PUBLICATION

(21) Application No.202141023572 A

(19) INDIA

(22) Date of filing of Application :27/05/2021

(43) Publication Date : 11/06/2021

(54) Title of the invention : A POWER TRANSMISSION NETWORK BASED ON OPTIMAL GENERALIZED INTERLINE POWER FLOW CONTROLLER (OGIPFC) FOR OPTIMAL POWER FLOW FOR COMPLEX NETWORKS TO MEET INCREASED LOAD DEMAND

(51) International classification	:H02J0003060000, H02J0003180000, G06N0005020000, G06N0005040000, G06F0111060000	(71) Name of Applicant : 1)CHAITANYA BHARATHI INSTITUTE OF TECHNOLOGY (AUTONOMOUS) Address of Applicant :Gandipet,Hyderabad, Telangana State-500075, India Telangana India
(31) Priority Document No	:NA	(72) Name of Inventor :
(32) Priority Date	:NA	1)Dr. M Balasubbareddy
(33) Name of priority country	:NA	2)Divyanshi Dwivedi
(86) International Application No	:PCT//	3)P.Venkata Prasad
Filing Date	:01/01/1900	
(87) International Publication No	: NA	
(61) Patent of Addition to Application Number	:NA	
Filing Date	:NA	
(62) Divisional to Application Number	:NA	
Filing Date	:NA	

(57) Abstract :

Recently, FACTS controllers have become part of transmission network as they have enhanced the static and dynamic performance of power system. A FACTS controller named as Optimal Generalized Interline Power Flow Controller (OGIPFC) is developed which is modelled using Power Injection Model (PIM) and Current Injection Model (CIM) and it is incorporated to improve performance of power system. Furthermore, for optimization a meta-heuristic method is proposed as Modified Marine Predator Algorithm (MMPA) which is recently developed algorithm Marine Predator Algorithm (MPA). The algorithm is restricted to solve the single objective problem only, so it is implemented with Non-dominating sorting to solve multi-objective optimization problem and multi-objective version is named as Non-dominating Sorting Modified Marine Predator Algorithm (NS-MMPA) and validated on test functions and IEEE-30 bus system. OPF problem has been solved with OGIPFC using MMPA and NS-MMPA which result in better solutions and make system more effective in operation

No. of Pages : 14 No. of Claims : 2

(12) PATENT APPLICATION
PUBLICATION

(21) Application No.202141023607 A

(19) INDIA

(22) Date of filing of Application
:27/05/2021

(43) Publication Date : 11/06/2021

(54) Title of the invention : Advanced Technology Vaccination Smart Card for Child & Adult Nutrition and Health Improvement Tracking Alert Management System.

(51) International classification	:G06Q0020340000, G06F0021340000, G06K0019077000, G06Q0030000000, G06K0019060000	(71) Name of Applicant : 1)M GURUSAMY Address of Applicant :2/50,MIDDLE STREET,PULIYANKULAM,CHITRAMPATTI(PO),KOVILPATTI(TK),THOOTHUKUDI(DIST) Tamil Nadu India
(31) Priority Document No	:NA	(72) Name of Inventor :
(32) Priority Date	:NA	1)M GURUSAMY
(33) Name of priority country	:NA	
(86) International Application No	:PCT//	
Filing Date	:01/01/1900	
(87) International Publication No	: NA	
(61) Patent of Addition to Application Number	:NA	
Filing Date	:NA	
(62) Divisional to Application Number	:NA	
Filing Date	:NA	

(57) Abstract :

The health of the baby is something that needs to be taken care of from the time a baby is born in the womb of a mother and vaccination is the primary duty and primary task of the parents to protect and improve the health of the baby. Is carried out and recorded in electronic form. It is used in the following ways. The data of parents and children are collected through an integrated smart card and stored through the web application. Then a separate user number is created that is for the users. A table is created with data stored by a unique system unique to each of the users. Through this table the beneficiary is vaccinated on the day of vaccination and that data is entered by an authorized employee and stored and stored online. This system 100% ensures that parents are notified and children are vaccinated in a timely manner with a predetermined day and time and is used for continuous monitoring. A set of computer and web utility software, the Internet, an integrated smart card, a system of electronic devices and a combination of telecommunications equipment. An integrated smart card is a set of systems with different modes. The package includes the following methods (i) QR code type techniques (ii) Barcode techniques (iii) RF ID with NFC technique (Wi-Fi card) (iv) EMV card techniques {(a) EMV Chip card (b) EMV Non Chip card} (v) Magnetic Strip Card Techniques. This system works through a combination of the above methods.

No. of Pages : 24 No. of Claims : 10

(12) PATENT APPLICATION PUBLICATION

(21) Application No.202141023734 A

(19) INDIA

(22) Date of filing of Application :28/05/2021

(43) Publication Date : 11/06/2021

(54) Title of the invention : AUTOMATIC SOLAR CUTTER

(51) International classification	:G05D0001020000, A01D0101000000, A01D0034000000, A01D0034780000, A01D0034730000	(71) Name of Applicant : 1)Er. Sreelal N Address of Applicant :Assistant Professor Department of Electrical and Electronics SAINTGITS College of Engineering, Kottukulam Hills Pathamuttom P. O Kottayam KERALA Kerala India
(31) Priority Document No	:NA	2)Anand S
(32) Priority Date	:NA	3)MOHAMMAD FAIS MIKDAD
(33) Name of priority country	:NA	4)Benson Mathew Sam
(86) International Application No Filing Date	:PCT// :01/01/1900	5)Ansu Mariam Kuruvilla
(87) International Publication No	: NA	(72) Name of Inventor :
(61) Patent of Addition to Application Number	:NA	1)Er. Sreelal N
Filing Date	:NA	2)Anand S
(62) Divisional to Application Number	:NA	3)MOHAMMAD FAIS MIKDAD
Filing Date	:NA	4)Benson Mathew Sam
		5)Ansu Mariam Kuruvilla

(57) Abstract :

The smart grass cutter system puts forth a completely automated lawn mower mechanism. The robotic vehicle is equipped with a grass cutter blade that allows for grass cutting at high RPM. The system has a smart functionality that allows it to cover the complete area of a lawn or garden by detecting corners using ultrasonic sensors and moving in a zig-zag manner in order to cover the entire area. The system uses a microcontroller-based circuit to achieve the functionality. It is a battery operated system. Battery is used to run the vehicle using DC motors and to power the grass cutter. The power is delivered to the battery using a solar panel and hence no external power source is required. The microcontroller operates the vehicle movement using dc motors as well as the cutter motor at the same time monitoring the ultrasonic sensors. The movement of the machine depends upon the feedback obtained from ultrasonic sensors. The microcontroller smartly operates the dc motors using motor driver IC to achieve the desired movement based on ultrasonic outputs. Thus, the system allows automated grass cutting mechanisms without the need for any human intervention. Manual option is also provided by using android smart phone-based application.

No. of Pages : 18 No. of Claims : 6

(12) PATENT APPLICATION PUBLICATION

(21) Application No.202141023738 A

(19) INDIA

(22) Date of filing of Application :28/05/2021

(43) Publication Date : 11/06/2021

(54) Title of the invention : Technologies Towards 5G Network for Intelligent Health Care Using IOT Notification with Machine Learning Programming.

<p>(51) International classification :H04L0029080000, G06N0020000000, H04L0029060000, H04L0012660000, H04L0012280000</p> <p>(31) Priority Document No :NA (32) Priority Date :NA (33) Name of priority country :NA (86) International Application No :PCT// Filing Date :01/01/1900 (87) International Publication No : NA (61) Patent of Addition to Application Number :NA Filing Date :NA (62) Divisional to Application Number :NA Filing Date :NA</p>	<p>(71)Name of Applicant : 1)Dr. Shubhangi Digamber Chikte (PROFESSOR) Address of Applicant :DEPARTMENT OF COMPUTER SCIENCE AND ENGINEERING, VISVESVARAYA TECHNOLOGICAL UNIVERSITY(VTU), CENTER FOR PG STUDIES, KALABURAGI-585105 KARNATAKA, INDIA. E-Mail: shubhangidc@vtu.ac.in +91-9448716838 Karnataka India 2)Shireen Fatima (RESEARCH SCHOLAR, VTU CPGS GULBARGA) 3)Preeti. M. Dandagi (RESEARCH SCHOLAR, VTU CPGS GULBARGA) 4)Priti (RESEARCH SCHOLAR, VTU CPGS GULBARGA) 5)Ayesha (RESEARCH SCHOLAR, VTU CPGS GULBARGA) 6)Zohra Naval (RESEARCH SCHOLAR, VTU CPGS GULBARGA) 7)Pratibha (RESEARCH SCHOLAR, VTU CPGS GULBARGA) 8)Uzma Sultana (RESEARCH SCHOLAR, VTU CPGS GULBARGA) 9)Pooja (RESEARCH SCHOLAR, VTU CPGS GULBARGA)</p> <p>(72)Name of Inventor : 1)Dr. Shubhangi Digamber Chikte (PROFESSOR) 2)Shireen Fatima (RESEARCH SCHOLAR, VTU CPGS GULBARGA) 3)Preeti. M. Dandagi (RESEARCH SCHOLAR, VTU CPGS GULBARGA) 4)Priti (RESEARCH SCHOLAR, VTU CPGS GULBARGA) 5)Ayesha (RESEARCH SCHOLAR, VTU CPGS GULBARGA) 6)Zohra Naval (RESEARCH SCHOLAR, VTU CPGS GULBARGA) 7)Pratibha (RESEARCH SCHOLAR, VTU CPGS GULBARGA) 8)Uzma Sultana (RESEARCH SCHOLAR, VTU CPGS GULBARGA) 9)Pooja (RESEARCH SCHOLAR, VTU CPGS GULBARGA)</p>
--	--

(57) Abstract :

ABSTRACT Our Invention Technologies Towards 5G Network for Intelligent Health Care Using IOT Notification with Machine Learning Programming is a Smart health-care is undergoing rapid transformation from the conventional specialist and hospital-focused style to a distributed patient-focused manner. The 5-G networks are being designed and developed to tackle the diverse communication needs of health-care applications in Internet of Things (IoT) under Machine Learning Programming. 5-G assisted Intelligent health-care networks are an amalgamation of IoT devices that require improved network performance and enhanced cellular coverage. The invention is a comprehensive research of 5G assisted Intelligent health-care solutions in ML and IoT a structure for Intelligent health-care in 5G by categorizing and classifying existing Technology. The speeds of +100 megabits per second,1 more data bandwidth, and fewer delays due to built-in computing intelligence that handles data very efficiently and also the new era of 5G will bring together improved connectivity, cloud-based storage, and an array of connected devices and services. The Invention can download an interactive 3-D video in a few seconds, a smart home anticipates your needs, and autonomous vehicles take you to your destination safely and also is the world of fifth-generation 5-G broadband technology.

No. of Pages : 15 No. of Claims : 6

(54) Title of the invention : Design and Fabrication of IoT based Solar Agriculture Weeder

<p>(51) International classification</p> <p>(31) Priority Document No</p> <p>(32) Priority Date</p> <p>(33) Name of priority country</p> <p>(86) International Application No Filing Date</p> <p>(87) International Publication No</p> <p>(61) Patent of Addition to Application Number Filing Date</p> <p>(62) Divisional to Application Number Filing Date</p>	<p>:A01B0039180000, A01M0021040000, G06Q0050100000, G16Z0099000000, A01M0021000000</p> <p>:NA</p> <p>:NA</p> <p>:NA</p> <p>:PCT// :01/01/1900</p> <p>: NA</p> <p>:NA</p> <p>:NA</p> <p>:NA</p> <p>:NA</p>	<p>(71)Name of Applicant : 1)St. Martin™s Engineering College Address of Applicant :Sy no 98 & 100, Dhulapally, Kompally Secenderabad Telangana India Telangana India</p> <p>(72)Name of Inventor : 1)Dr. P. Santosh Kumar Patra, Principal & Professor / Department of Computer Science & Engineering / SMEC 2)Dr. D.V. Sreekanth, Professor & HOD / Department of Mechanical Engineering/SMEC. 3)Dr. N. Ramachandra, Professor & HOD/ Department of Electrical & Electronics Engineering/SMEC. 4)Dr. B. Hari Krishna, Professor & HOD/ Department of Electronics & Communication Engineering/SMEC 5)Dr. M. Narayanan, Professor & HOD/ Department of Computer Science & Engineering/SMEC 6)Dr. R. Nagaraju, Professor & HOD/ Department of Information Technology/SMEC 7)Dr. D. Ranadheer Reddy, Professor & HOD/ Department of Science and Humanities/SMEC 8)Dr. T. Poongothai, Professor & HOD/ Department of Computer Science (AI & ML)/SMEC 9)Dr. S.V.S Rama Krishnam Raju Professor, ECE Department / Dean Academics/SMEC 10)Prof. J.K. Sandhya Kiran Professor & HOD/ Department of Civil Engineering/SMEC</p>
--	---	--

(57) Abstract :

Weed control is one of the most difficult tasks in agriculture that accounts for a considerable share of the cost involved in agricultural production. Farmers generally expressed their concern for effective weed control measures to arrest the growth and propagation of weeds. Chemical method of weed control is more prominent than manual and mechanical methods. It is the most widely used weed control method but it is labor intensive. However, agriculture weeder is used to reduce work intensity and increase the outcome. Agriculture weeder is very effective as it helps to reduce drudgery involved in manual weeding, it kills the weeds and also keeps the soil surface loose ensuring soil aeration and water intake capacity. Weeding is an important but equally labor-intensive agricultural unit operation. There is an increasing interest in the use of agriculture intra-row weeders because of concern over environmental degradation and a growing demand for organically produced food. Today the agricultural sector requires agriculture weeder that ensures food safety. Consumers demand high quality food products and pay special attention to food safety. Through the technical development of mechanisms for physical weed control, such as precise inter-and intra-row weeders, it might be possible to control weeds in a way that meets consumer demands. These agriculture weeders help in time consumption and increase the product it is easy to build, low cost and it only consist of mother, battery, plowing toll and wheel for easy motion, these weeders not only remove weeds but also unwanted mud or sand around the trees, these types of weeder are important to Farmers to help them increase the product out come and decrease the manual labor. This work discusses the design and development of an IoT based solar Agri weeder that automates irrigation task and enables remote farm monitoring. Agricultural weeder acts as an IoT device and transmits the data collected from multiple sensors to a remote server using Wi-Fi link. At the remote server, raw data is processed using signal processing operations such as filtering, compression and prediction. Accordingly, the analyzed data statistics are displayed using an interactive interface, as per user request.

No. of Pages : 18 No. of Claims : 6

(12) PATENT APPLICATION PUBLICATION

(21) Application No.202141023779 A

(19) INDIA

(22) Date of filing of Application :28/05/2021

(43) Publication Date : 11/06/2021

(54) Title of the invention : BOOK REVIEW SESSION (BRS) BEST PRACTICE - SIVA SIVANI INSTITUTE OF MANAGEMENT

(51) International classification	:G06Q0050200000, G09B0005140000, B42D0001000000, G06Q0090000000, B42D0015000000	(71) Name of Applicant : 1)Siva Sivani-Institute of Management Address of Applicant :NH-44 Kompally Secenderabad Telangana India Telangana India
(31) Priority Document No	:NA	(72) Name of Inventor :
(32) Priority Date	:NA	1)Dr. S.V. Ramana Rao, Director / SSIM
(33) Name of priority country	:NA	2)Dr. S.F. Chandra Sekhar, Professor / SSIM
(86) International Application No	:PCT//	3)Mr. K. Sreehari, Associate Professor / SSIM
Filing Date	:01/01/1900	4)Dr.K. S. Harish, Professor / SSIM
(87) International Publication No	: NA	5)Dr.Pavan Patel, Professor / SSIM
(61) Patent of Addition to Application Number	:NA	6)Dr. N.C. Rajya Lakshmi, Professor / SSIM
Filing Date	:NA	
(62) Divisional to Application Number	:NA	
Filing Date	:NA	

(57) Abstract :

Abstract: A review is a critical evaluation of a text, event, object, or phenomenon. Reviews can consider books, articles, entire genres or fields of literature, architecture, art, fashion, restaurants, policies, exhibitions, performances, and many other forms. This work focus on book reviews. Book Review objective is clearly conveying the book contents and critical perspective of the book essence to the students in the class. The sessions provide an opportunity to students to learn about the summary of bookTMs content(s). Reviewers should consider the value of the book related to the business field which must facilitate in augmenting the studentTMs business comprehension and add value to their business knowledge. This work highlights the book review methods adopted and effectively implemented in Siva Sivani Institute of Management. SSIM inculcated this best practice in the curriculum and provided an opportunity to students to learn about the summary of bookTMs content(s), formatting, organizing and evaluating etc.

No. of Pages : 9 No. of Claims : 4

(12) PATENT APPLICATION PUBLICATION

(21) Application No.202141023786 A

(19) INDIA

(22) Date of filing of Application :28/05/2021

(43) Publication Date : 11/06/2021

(54) Title of the invention : A NOVEL SYSTEM BASED ON RANDOM SAMPLE CONSENSUS (RANSAC) FOR IRIS RECOGNITION IN NON-IDEAL IMAGING CONDITIONS

(51) International classification	:G06K0009000000, G06T0007330000, G06T0007000000, G06F0016230000, G06T0007285000	(71)Name of Applicant : 1)Mr.G R Anil Address of Applicant :Research Scholar, School of Computer and information Sciences, University of Hyderabad, Hyderabad, Telangana, India. Pin Code:500046 Telangana India 2)Dr.Dumala Anveshini 3)Dr.Shaik Meera Sharief 4)Dr.Ramesh Babu Vallabhaneni 5)Dr.Karthikeyan Palaniappan 6)Mrs.R.Janaki 7)Dr.T.Sheela 8)Dr.Sushma Jaiswal 9)Mr.Tarun Jaiswal 10)Mr.Miranji Katta
(31) Priority Document No	:NA	(72)Name of Inventor : 1)Mr.G R Anil 2)Dr.Dumala Anveshini 3)Dr.Shaik Meera Sharief 4)Dr.Ramesh Babu Vallabhaneni 5)Dr.Karthikeyan Palaniappan 6)Mrs.R.Janaki 7)Dr.T.Sheela 8)Dr.Sushma Jaiswal 9)Mr.Tarun Jaiswal 10)Mr.Miranji Katta
(32) Priority Date	:NA	
(33) Name of priority country	:NA	
(86) International Application No	:PCT//	
Filing Date	:01/01/1900	
(87) International Publication No	: NA	
(61) Patent of Addition to Application Number	:NA	
Filing Date	:NA	
(62) Divisional to Application Number	:NA	
Filing Date	:NA	

(57) Abstract :

ABSTRACT A NOVEL SYSTEM BASED ON RANDOM SAMPLE CONSENSUS (RANSAC) FOR IRIS RECOGNITION IN NON-IDEAL IMAGING CONDITIONS [032] The present invention discloses a system based on random sample consensus (RANSAC) for iris recognition in non-ideal imaging conditions and method thereof. The system includes, but not limited to, a processing unit adapted to evaluate noisy factors from an iris captured image in non-ideal conditions. The processing unit is further configured to localize the iris boundaries more accurately through random sample consensus (RANSAC) and a deep learning module, and further, configured to have a registration interface for storing the filtered iris image data into an online or local database unit. In addition, the random sample consensus (RANSAC) module is configured to divide the iris image data into small-sub images. Accompanied Drawing [FIG. 1]

No. of Pages : 20 No. of Claims : 8

(12) PATENT APPLICATION PUBLICATION

(21) Application No.202141023964 A

(19) INDIA

(22) Date of filing of Application :29/05/2021

(43) Publication Date : 11/06/2021

(54) Title of the invention : COMPANY REVIEW SESSION BEST PRACTICE- SIVA SIVANI INSTITUTE OF MANAGEMENT

(51) International classification	:G06Q0010060000, G06Q0010100000, G06Q0050200000, G06F0021300000, B42D0015000000	(71) Name of Applicant : 1)Siva Sivani-Institute of Management Address of Applicant :Siva Sivani Institute of Management NH-44, Kompally Secenderabad Telangana India 500100 Telangana India
(31) Priority Document No	:NA	(72) Name of Inventor :
(32) Priority Date	:NA	1)Mr. Pardhasaradhi Madasu, Associate Professor / SSIM
(33) Name of priority country	:NA	2)Dr. V. Annapurna, Associate Professor / SSIM
(86) International Application No	:PCT//	3)Mr. T. Thirumal Reddy, Assistant Professor / SSIM
Filing Date	:01/01/1900	4)Ms. Daman deep Johar, Assistant Professor / SSIM
(87) International Publication No	: NA	5)Dr. Arijit Santikary, Associate Professor / SSIM
(61) Patent of Addition to Application Number	:NA	6)Ms. K Grace Mani, Assistant Professor / SSIM
Filing Date	:NA	
(62) Divisional to Application Number	:NA	
Filing Date	:NA	

(57) Abstract :

Abstract : Company Review Session (CRS) followed at Siva Sivani Institute of Management (SSIM) is to get an overview of a Company, its Management Team who drive the Company, its location, mission and legal structure. These sessions aim to inculcate business sense by familiarizing the student with the corporates™ performance metrics, customer metrics and people metrics, business reporting language and strategies, organizational culture and its ethical framework. It is an opportunity for the student to visit and explore his or her Dream Company • and to understand the Quality standards required for shaping and designing for their career opportunities in such corporates. This activity presents a plethora of opportunities to the students to select from the innumerable companies within and outside India. Time and distance is no more a limitation due to the technology. This system is implemented and successfully operating in Siva Sivani Institute of Management.

No. of Pages : 10 No. of Claims : 4

(12) PATENT APPLICATION PUBLICATION

(21) Application No.202141023989 A

(19) INDIA

(22) Date of filing of Application :29/05/2021

(43) Publication Date : 11/06/2021

(54) Title of the invention : A System and Method for Secure Fish Farming Using Internet of things

(51) International classification	:G06F0021640000, G06F0016230000, H04L0009060000, G06Q0050020000, G06T0007200000	(71)Name of Applicant : 1)Prof.Bineet Kumar Jha, CMR Institute of Technology Address of Applicant :CMR Institute of Technology, AECS Layout, Bengaluru, Karnataka, India 560037. Karnataka India 2)Dr. Akana Chandra Mouli Venkata Srinivas, AMC engineering college 3)Prof. Dheeraj D, Global Academy of Technology 4)Chiyvedu Manasa, Global Academy of Technology 5)Dr. Asha jyothi ch, JNTUH, Jagithyal 6)NazneenTaj, KNS Institute of Technology
(31) Priority Document No	:NA	(72)Name of Inventor : 1)Prof.Bineet Kumar Jha, CMR Institute of Technology 2)Dr. Akana Chandra Mouli Venkata Srinivas, AMC engineering college 3)Prof. Dheeraj D, Global Academy of Technology 4)Chiyvedu Manasa, Global Academy of Technology 5)Dr. M.Shahina Parveen ,CMR Institute of Technology 6)Dr. Asha Jyothi ch, JNTUH,Jagithyal
(32) Priority Date	:NA	
(33) Name of priority country	:NA	
(86) International Application No	:PCT//	
Filing Date	:01/01/1900	
(87) International Publication No	: NA	
(61) Patent of Addition to Application Number:	:NA	
Filing Date	:NA	
(62) Divisional to Application Number	:NA	
Filing Date	:NA	

(57) Abstract :

The system proposes a generic interaction method to integrate a legacy fish farm system with the blockchain by using a RESTful interface. Besides, this interface obstructs the interaction with other distributed systems since it can be customized to meet different scenarios and requirements. Agriculture data are known to be messy, especially from combine yield monitors, and analysts are concerned with the validity of data, especially given that other people may have impacted data quality at various steps along the data path. The blockchain can be a possible solution to the analyst's problem of uncertain data quality from prior data manipulation since it ensures data have not been inappropriately manipulated or at the very least documents what changes have been made by specific individuals. This work proposes a blockchain-based fish farm platform to ensure agriculture data integrity. The designed System aims to provide fish farmers with secure storage for preserving the large amounts of agriculture data that cannot be tampered with. Diverse processes of the fish farm are executed automatically by using the smart contract to reduce the risk of error or manipulation. A proof of concept that integrates a legacy fish farm system with the Hyperledger Fabric blockchain is implemented on top of the proposed architecture. The efficiency and usability of the proposed platform are demonstrated through a series of experiments using various metrics.

No. of Pages : 14 No. of Claims : 7

(12) PATENT APPLICATION PUBLICATION

(21) Application No.202141023998 A

(19) INDIA

(22) Date of filing of Application :29/05/2021

(43) Publication Date : 11/06/2021

(54) Title of the invention : SMART HELMET FOR SMART WORKERS

(51) International classification	:H04L0012260000, A42B0003040000, G08B0021120000, G07C0001100000, G08B0021180000	(71) Name of Applicant : 1)Jyothis Kumar D Address of Applicant :Department of Electrical and Electronics Engineering SAINTGITS College of Engineering, Kottukulam Hills Pathamuttom P. O Kottayam 686532 KERALA Kerala India
(31) Priority Document No	:NA	2)Jerin Antony
(32) Priority Date	:NA	3)Aakarsh S Kumar
(33) Name of priority country	:NA	4)Aneesha Joseph
(86) International Application No	:NA	5)Er. Merin Antony
Filing Date	:NA	(72) Name of Inventor :
(87) International Publication No	: NA	1)Jyothis Kumar D
(61) Patent of Addition to Application Number	:NA	2)Jerin Antony
Filing Date	:NA	3)Er. Merin Antony
(62) Divisional to Application Number	:NA	4)Aakarsh S Kumar
Filing Date	:NA	5)Aneesha Joseph

(57) Abstract :

Industrial jobs are among the most hazardous, given the conditions that workers face on a regular basis. Gas poisoning, falling objects and exposure to high temperatures are just some of the causes of occupational accidents. As a result, safety is paramount in these places. To ensure that, the proposed system employs a remote sensor network to track the working environment in real time from a monitoring station. It continuously monitors the air quality, as well as the temperature and physical movement of the workers. The limit switch ensures whether or not the helmet is properly worn or not. In addition to these protection measures a RFID attendance sensing device is also provided. The information and data is transmitted and processed using Wi-Fi and IoT technologies.

No. of Pages : 23 No. of Claims : 5

(54) Title of the invention : Smart IoT Wearable device for Heartbeat Rate Monitoring and Alerting System for COVID Patients

<p>(51) International classification :A61B0005024000, A61B0005000000, G16H0050300000, G16H0080000000, G16H0040670000</p> <p>(31) Priority Document No :NA</p> <p>(32) Priority Date :NA</p> <p>(33) Name of priority country :NA</p> <p>(86) International Application No :PCT// Filing Date :01/01/1900</p> <p>(87) International Publication No : NA</p> <p>(61) Patent of Addition to Application Number :NA Filing Date :NA</p> <p>(62) Divisional to Application Number :NA Filing Date :NA</p>	<p>(71)Name of Applicant :</p> <p>1)Dr.V.Arulkumar, Sri Krishna College of Engineering and Technology, Coimbatore Address of Applicant :Assistant Professor, Computer Science and Business Systems (TCS), Sri Krishna College of Engineering and Technology, Coimbatore. Tamil Nadu India</p> <p>2)Dr.R.Lokeshkumar, Vellore Institute of Technology, Vellore</p> <p>3)Mr D.Selvapandian, Karpagam Academy of Higher Education, Coimbatore</p> <p>4)Mr A. Ranjith, St. Joseph university in Tanzania</p> <p>5)Mr S.Arockia Jayadhas, St.Joseph University in Tanzania</p> <p>6)Dr Prabhakaran Paulraj, St Joseph University in Tanzania</p> <p>(72)Name of Inventor :</p> <p>1)Dr.V.Arulkumar, Sri Krishna College of Engineering and Technology, Coimbatore</p> <p>2)Dr.R.Lokeshkumar, Vellore Institute of Technology, Vellore</p> <p>3)Mr D.Selvapandian, Karpagam Academy of Higher Education, Coimbatore</p> <p>4)Mr A. Ranjith, St. Joseph university in Tanzania</p> <p>5)Mr S.Arockia Jayadhas, St.Joseph University in Tanzania</p> <p>6)Dr Prabhakaran Paulraj, St Joseph University in Tanzania</p>
--	--

(57) Abstract :

A pulse monitoring system has been developed using IoT technology to monitor a patient's pulse to determine the risk of heart attack and a routine physical exam. The physical exam is very important for us to make sure that our health is in the best condition. One of the main parameters of this tool to consider is heart rate (HR). This medicine is a natural solution for the prevention and treatment of most diseases. Many high-risk illnesses can be treated and prevented with appropriate medications. The main purpose of the system we are offering is to provide an easy to use design and can be used to remind patients to take their daily medications on time. The portable device is designed to be used for heart rate monitoring. When a significant change in heart rate occurs, the user will receive a vibration notification to take the required medication. Emails are also sent to notify users. In this project, we will describe the design of an affordable, handy heart rate monitor using Bluetooth technology. The whole system consists of several parts such as heart rate module, app and Android module. The Heart Rate Module (HR) receives heart rate signals using non-invasive techniques. (Photoplethysmography) transmits (signals) objects (patients) and wirelessly to a computer or this system, an Android application that uses a Bluetooth module, can be used and integrated as part of the telemedicine component. Heart rate module data can be stored and studied for medical purposes. The results of the prototype of this device can be used in various clinical studies, in fact this Bluetooth signal can be transmitted within a range of 15 to 20 meters.

No. of Pages : 8 No. of Claims : 4

(54) Title of the invention : ANALYSIS OF IMPACTS OF THE USE OF SOLID RECOVERED FUEL IN POLLUTANTS FOUND IN GASIFICATION

<p>(51) International classification</p> <p>(31) Priority Document No</p> <p>(32) Priority Date</p> <p>(33) Name of priority country</p> <p>(86) International Application No</p> <p style="padding-left: 20px;">Filing Date</p> <p>(87) International Publication No</p> <p>(61) Patent of Addition to Application Number</p> <p style="padding-left: 20px;">Filing Date</p> <p>(62) Divisional to Application Number</p> <p style="padding-left: 20px;">Filing Date</p>	<p>:B01D0053320000, C10B0053000000, C08L0071020000, F23G0007000000, C10L0010020000</p> <p>:NA</p> <p>:NA</p> <p>:NA</p> <p>:PCT//</p> <p style="padding-left: 20px;">:01/01/1900</p> <p>: NA</p> <p>:NA</p> <p>:NA</p> <p>:NA</p> <p>:NA</p>	<p>(71)Name of Applicant :</p> <p>1)Dr.M.SARAVANAN Address of Applicant :SENIOR PROFESSOR & VICE PRINCIPAL, DEPARTMENT OF MECHANICAL ENGINEERING, PONJESLY COLLEGE OF ENGINEERING, PONJESLY, COLLEGE RD, PARVATHIPURAM, NAGERCOIL, TAMIL NADU- 629003 Tamil Nadu India</p> <p>2)Dr. S. SENTHIL KUMAR,</p> <p>3)Mrs.D.N.ROOPA</p> <p>4)Mr. BHARATH. M.N</p> <p>5)Dr. M. PANDIAN</p> <p>6)Dr.S.NAVANEETHAKRISHNAN</p> <p>7)Dr. C. GNANAVEL</p> <p>8)Dr. MOTI LAL RINAWA</p> <p>9)Mr. KALIYA PERUMAL PALANISAMY</p> <p>10)Dr. M.RAMARAO</p> <p>11)Mr. NAGARAJA. T. K.</p> <p>(72)Name of Inventor :</p> <p>1)Dr.M.SARAVANAN</p> <p>2)Dr. S. SENTHIL KUMAR,</p> <p>3)Mrs.D.N.ROOPA</p> <p>4)Mr. BHARATH. M.N</p> <p>5)Dr. M. PANDIAN</p> <p>6)Dr.S.NAVANEETHAKRISHNAN</p> <p>7)Dr. C. GNANAVEL</p> <p>8)Dr. MOTI LAL RINAWA</p> <p>9)Mr. KALIYA PERUMAL PALANISAMY</p> <p>10)Dr. M.RAMARAO</p> <p>11)Mr. NAGARAJA. T. K.</p>
---	--	--

(57) Abstract :

ANALYSIS OF IMPACTS OF THE USE OF SOLID RECOVERED FUEL IN POLLUTANTS FOUND IN GASIFICATION Wood air gasification produces polluting compounds, as a thermochemical conversion process, and the use of SRFs, containing more precursors of pollutants than wood, was therefore likely to produce more pollutants or even new pollutants. The SRFs studied in this work show higher sulfur, nitrogen and heavy metals. As can be thought in an intuitive way, it can be shown that, overall, an increase in these precursors of pollutants in entry fuels leads to higher pollutant concentrations in effluents, and even the presence of new polluting compounds. Thus, the addition of plastic in the SRF mixture leads to higher tarmakers. The increase in plastic leads to an increase in vapor phase compounds in the reactor, and thus to a local fuel enrichment in the combustion zone. The air coming to the same flow, cannot consume everything, which leads to more tar. The addition of tires, containing benzene cycles and PAHs in its composition, leads to an increase in these compounds in effluents.

No. of Pages : 19 No. of Claims : 3

(54) Title of the invention : INTELLIGENT INDOOR HEALTH MONITORING FRAMEWORK USING LOW ENERGY BLUETOOTH BEACONS

<p>(51) International classification</p> <p>(31) Priority Document No</p> <p>(32) Priority Date</p> <p>(33) Name of priority country</p> <p>(86) International Application No Filing Date</p> <p>(87) International Publication No</p> <p>(61) Patent of Addition to Application Number Filing Date</p> <p>(62) Divisional to Application Number Filing Date</p>	<p>:H04W0004800000, A61B0005000000, A61B0005010000, G01N0023040000, A61B0005145000</p> <p>:NA</p> <p>:NA</p> <p>:NA</p> <p>:PCT// :01/01/1900</p> <p>: NA</p> <p>:NA</p> <p>:NA</p> <p>:NA</p>	<p>(71)Name of Applicant :</p> <p>1)Dr. Ramesh Kumar Address of Applicant :Senior Manager, Product Management, #206, Viveks Sanskaar Apartments, 7th cross, Belathur Main Road, Bangalore - 560067, Karnataka, India. Karnataka India</p> <p>2)Mr. Shanavas T N</p> <p>3)Dr. N. Renuga Devi M.Sc., M.Phil., Ph.D.,</p> <p>4)Dr. Bos Mathew Jos</p> <p>5)Mr. Satish Sampatrao Salunkhe</p> <p>6)Dr. Vaishali D. Khairnar</p> <p>7)Mr. Sanchit Manish Kabra</p> <p>8)Dr. Shilpa S. Laddha</p> <p>(72)Name of Inventor :</p> <p>1)Dr. Ramesh Kumar</p> <p>2)Mr. Shanavas T N</p> <p>3)Dr. N. Renuga Devi M.Sc., M.Phil., Ph.D.,</p> <p>4)Dr. Bos Mathew Jos</p> <p>5)Mr. Satish Sampatrao Salunkhe</p> <p>6)Dr. Vaishali D. Khairnar</p> <p>7)Mr. Sanchit Manish Kabra</p> <p>8)Dr. Shilpa S. Laddha</p>
--	--	---

(57) Abstract :

To check the individual strength of people the current innovation gives a proficient method. For checking individual indispensable signs information Bluetooth low energy- based sensors can be considered as an answer. To assist diabetic patients with bettering self-deal with their ongoing condition by using a Bluetooth low energy -based sensor gadget, ongoing information handling, and Artificial intelligence-based calculations were proposed and customized medical services checking framework in this invention. To accumulate clients' crucial signs information Bluetooth low energy were utilized like weight, blood glucose and pulse from sensor hubs to cell phones, while to deal with the huge measure of consistently produced sensor information ongoing information preparation was used.

No. of Pages : 12 No. of Claims : 6

(54) Title of the invention : HUMAN ACTION ACKNOWLEDGMENT UTILIZING DEEP LEARNING WITH PROFOUND PORTRAYALS

<p>(51) International classification :G06N0003040000, G06N0003080000, G06Q0030060000, G16H0050200000, A61B0005000000</p> <p>(31) Priority Document No :NA (32) Priority Date :NA (33) Name of priority country :NA (86) International Application No :PCT// Filing Date :01/01/1900 (87) International Publication No : NA (61) Patent of Addition to Application Number :NA Filing Date :NA (62) Divisional to Application Number :NA Filing Date :NA</p>	<p>(71)Name of Applicant :</p> <p>1)MAHESWARA REDDY SURA Address of Applicant :Professor, Department of ECE, Guru Nanak Institutions Technical Campus, Hyderabad, Telangana, India Telangana India</p> <p>2)K. SUSEELA 3)C. M. SRI PRIYA 4)R. DIVYA 5)T SRINIVASA PADMAJA 6)Dr. MOHAMMED KHAJA NIZAMUDDIN 7)D. SURENDRA RAO 8)VORUCHU SAI BABU 9)O. RAVINDER 10)Dr. K. SHASHIDHAR 11)SRINIVAS NANDA 12)K. KRISHNA KUMAR</p> <p>(72)Name of Inventor :</p> <p>1)MAHESWARA REDDY SURA 2)K. SUSEELA 3)C. M. SRI PRIYA 4)R. DIVYA 5)T SRINIVASA PADMAJA 6)Dr. MOHAMMED KHAJA NIZAMUDDIN 7)D. SURENDRA RAO 8)VORUCHU SAI BABU 9)O. RAVINDER 10)Dr. K. SHASHIDHAR 11)SRINIVAS NANDA 12)K. KRISHNA KUMAR</p>
--	---

(57) Abstract :

ABSTRACT HUMAN ACTION ACKNOWLEDGMENT UTILIZING DEEP LEARNING WITH PROFOUND PORTRAYALS In recent decades, specialists have been paying a lot of attention towards human activity acknowledgment in view of its various applications. These applications include Human Computer Interaction, video observation, Ambient Assisted Living, amusement, and keen driving. The deep inclining-based methodologies have uncovered the noteworthy advancement for activity acknowledgment in recordings. The deep learning model presented for decreasing the dimensionality of the information, and Deep Belief Networks (DBNs) have been broadly utilized for picture characterization, object acknowledgment, and activity acknowledgment. Due to large amounts of data on the internet like pictures, sounds, and recordings, requests for high exactnesses and computational efficiencies are expanded. Because of these reasons, the learning has pulled in a great deal of interests in the regions of AI and computer vision. Figure 2

No. of Pages : 10 No. of Claims : 5

(54) Title of the invention : AUTOMATIC BILLING SYSTEM FOR SOLAR AND KSEB POWERED SMART ELECTRICAL SYSTEM USING BLOCKCHAIN

(51) International classification	:G06Q0050060000, G01D0004000000, G01R0022060000, G01R0021000000, H02J0007350000	(71)Name of Applicant : 1)Er. Arun Sebastian Address of Applicant :Assistant Professor Department of Electrical and Electronics Engineering SAINTGITS College of Engineering, Kottukulam Hills Pathamuttom P. O Kottayam 686532 KERALA Kerala India 2)Abhishek Binu 3)Alwin Saji 4)Bharath Krishnan 5)Er. Gokulnath G 6)S. Keerthana
(31) Priority Document No	:NA	(72)Name of Inventor : 1)Er. Arun Sebastian 2)Abhishek Binu 3)Alwin Saji 4)Bharath Krishnan 5)Er. Gokulnath G 6)S. Keerthana
(32) Priority Date	:NA	
(33) Name of priority country	:NA	
(86) International Application No	:PCT//	
Filing Date	:01/01/1900	
(87) International Publication No	: NA	
(61) Patent of Addition to Application Number	:NA	
Filing Date	:NA	
(62) Divisional to Application Number	:NA	
Filing Date	:NA	

(57) Abstract :

Nowadays measurement of energy, especially electricity consumption becomes a major issue in big cities. It is because big cities involve many electricity consumers, therefore measurement and planning of the electricity network is difficult. Transactions between distributors and consumers are not automated. There is no transparency in traditional energy billing and distribution systems. Most of the metering system still rely upon the traditional system of manual consumption meter readings. Current energy consumption levels cannot be monitored in traditional systems. These metering processes is time consuming and inefficient. Since these systems are non-transparent and centralized there can be trust issues. Customers are not aware of the process and their personal data can be vulnerable to attacks or misuse, so there is a need for the instant view of active energy usage. The main objective of the project is to propose a system which uses blockchain technology for the metering and billing of the customerTMs energy consumption for the electric network. There by solving the trust and privacy issues of customers. It helps to identify energy consumption from both solar and KSEB separately. Blockchain can provide safer and more transparent solutions with its decentralized structure. The entire system primarily works on solar power and if the solar power is unavailable it automatically shifts to KSEB. Another important objective is the smart controlling of lighting and other devices. Efficient and automated control of lighting and other devices are necessary.

No. of Pages : 13 No. of Claims : 3

(12) PATENT APPLICATION PUBLICATION

(21) Application No.202141024073 A

(19) INDIA

(22) Date of filing of Application :30/05/2021

(43) Publication Date : 11/06/2021

(54) Title of the invention : ONLINE MARKETING - HOW CONSUMERS RESPOND TO THE SCHEMES OF INTERNET MARKETING

(51) International classification	:G06Q0030020000, G06Q0050000000, H04H0060320000, G09B0025000000, H04N0009820000	(71) Name of Applicant : 1)Dr. N. SRINIVAS KUMAR Address of Applicant :PROFESSOR & ASSISTANT DIRECTOR, SCHOOL OF MANAGEMENT STUDIES, GURU NANAK INSTITUTIONS TECHNICAL CAMPUS KHANAPUR VILLAGE, MANCHAL, IBRAHIMPATNAM, TELANGANA- 501506 Telangana India
(31) Priority Document No	:NA	(72) Name of Inventor :
(32) Priority Date	:NA	1)Dr. N. SRINIVAS KUMAR
(33) Name of priority country	:NA	
(86) International Application No	:PCT//	
Filing Date	:01/01/1900	
(87) International Publication No	: NA	
(61) Patent of Addition to Application Number	:NA	
Filing Date	:NA	
(62) Divisional to Application Number	:NA	
Filing Date	:NA	

(57) Abstract :

ONLINE MARKETING - HOW CONSUMERS RESPOND TO THE SCHEMES OF INTERNET MARKETING Traditional marketing tactics are well-known by firms around the globe, although there are few innovative options for promoting competition. And then there's online marketing, which has almost infinite opportunities and choices. This research looked at the increasing significance of online marketing, as well as a number of online marketing schemes. It also includes a concise overview of online marketing, as well as simple internet schemes and the response to the problem. The findings of the analysis would aid web advertisers in developing better targeting strategies to affect customers' buying intentions and purchasing behaviour. The data was obtained using the chosen structures borrowed from the literature. The PLS-SEM methodology was used to test the conceptual model using survey data from 392 Indian consumers. The study validates a conceptual model that creates a connection between numerous marketing schemes and purchase intention and consumer purchasing behaviour. Influencer marketing, social network marketing, eWOM, and viral marketing all have a huge impact on purchase intention, according to the study. Email marketing and content marketing, on the other side, have no effect on purchasing intention and purchase intention leads to consumer purchasing behavior.

No. of Pages : 14 No. of Claims : 1

(12) PATENT APPLICATION PUBLICATION

(21) Application No.202141024082 A

(19) INDIA

(22) Date of filing of Application :30/05/2021

(43) Publication Date : 11/06/2021

(54) Title of the invention : A DIET AND WORKOUT RECOMMENDATION SYSTEM USING IMPROVED CONDITIONAL RESTRICTED BOLTZMANN MACHINES (CRBM) AND METHOD THEREOF

(51) International classification	:G06Q0050220000, G06N0003040000, G06N0003080000, A61K0038300000, G06F0021000000	(71)Name of Applicant : 1)Dr. Vaishali M Deshmukh Address of Applicant :Department of Computer Science & Engineering, New Horizon College of Engineering, Bengaluru, India Karnataka India
(31) Priority Document No	:NA	2)Dr. Samiksha Shukla
(32) Priority Date	:NA	3)Dr. Jossy P George
(33) Name of priority country	:NA	(72)Name of Inventor :
(86) International Application No	:PCT//	1)Dr. Vaishali M Deshmukh
Filing Date	:01/01/1900	2)Dr. Samiksha Shukla
(87) International Publication No	: NA	3)Dr. Jossy P George
(61) Patent of Addition to Application Number	:NA	
Filing Date	:NA	
(62) Divisional to Application Number	:NA	
Filing Date	:NA	

(57) Abstract :

ABSTRACT A DIET AND WORKOUT RECOMMENDATION SYSTEM USING IMPROVED CONDITIONAL RESTRICTED BOLTZMANN MACHINES (CRBM) AND METHOD THEREOF [049] The present invention discloses a diet and workout recommendation system using improved Conditional Restricted Boltzmann Machines (CRBM) and method thereof. The system includes, but not limited to, one or more processor provided in a computer network; and a memory disposed in communication with each of the processor and storing processor executable instructions, the instructions comprising instructions to: process varied datasets of Food items and various nutrient parameters of Food items with respect to their ratings by various food takers and while recommending for a patient or a target user; estimate the closest neighbours with rating similarity and disease type food-item similarity; create a Conditional Restricted Boltzmann Machines (CRBM) model with a plurality of hidden units and visible units; define a joint distribution over visible variables units and hidden units by using a singular value decomposition (SVD) matrix factorization module; and provides the diet and workout plans to the target user. Accompanied Drawing [FIG. 1]

No. of Pages : 26 No. of Claims : 10

(12) PATENT APPLICATION PUBLICATION

(21) Application No.202141024093 A

(19) INDIA

(22) Date of filing of Application :31/05/2021

(43) Publication Date : 11/06/2021

(54) Title of the invention : Diagnosis and Analysis Brain Tumor Using Image Segmentation Technique.

(51) International classification	:G06K0009620000, G06T0007000000, A61B0005055000, G16H0010600000, G06T0007120000	(71) Name of Applicant : 1)Prof (Dr.) Baswaraj Gadgay (Regional Director) Address of Applicant :Visvesvaraya Technological University (VTU), Regional Campus, Kalaburagi-585105, Karnataka, India. E-mail : b_gadgay@rediffmail.com E-mail: baswaraj_gadgay@vtu.ac.in Mobile No.: +91 9448754546 Karnataka India
(31) Priority Document No	:NA	2)Mr. Thri vikram Bathini (Assistant Professor)
(32) Priority Date	:NA	(72) Name of Inventor :
(33) Name of priority country	:NA	1)Prof (Dr.) Baswaraj Gadgay (Regional Director)
(86) International Application No	:PCT//	2)Mr. Thri vikram Bathini (Assistant Professor)
Filing Date	:01/01/1900	
(87) International Publication No	: NA	
(61) Patent of Addition to Application	:NA	
Number	:NA	
Filing Date	:NA	
(62) Divisional to Application Number	:NA	
Filing Date	:NA	

(57) Abstract :

ABSTRACT Our Invention Diagnosis and Analysis Brain Tumor Using Image Segmentation Technique is to an image are considered as most important invention of data/ information transfer. The invention images have to be analysis and information from them is extracted for further processing this is an important feature of Machine learning programming and alos the radiologists use X-rays, MRIs etc., and from these types of images, the work required commonality, time for processing or consumption and hence demand automation. Medical image processing is an important aspect in diagnosis and treatment strategy and also the tremendous volume of medical data has accelerated the need for automated analysis of this image, more so in the case Magnetic Resonance Imaging (MRI). The planned SVM classifier used a kernel within the sort of Gaussian radial basis operate kernel (GRB kernel) to boost the classifier performance. The performance of the classifier has been valid through professional clinical opinion and calculation of performance measures. The results amply illustrate the quality of the planned classifier.

No. of Pages : 15 No. of Claims : 5

(54) Title of the invention : I-Mobile Charger: Automatic Disconnect the Charger if Mobile Battery Status-97%.

(51) International classification	:H02J0007000000, H04M0001040000, A61N0001020000, H04B0001388300, H02S0020100000	(71)Name of Applicant : 1)Dr. D. M. K. Chaitanya (Associate Professor) Address of Applicant :E.C.E Department, Vasavi College of Engineering, Ibrahimbagh, Hyderabad-500031, India. E-mail ID: chaitanyadm@gmail.com Telangana India
(31) Priority Document No	:NA	2)Srilakshmi Aouthu (Associate Professor)
(32) Priority Date	:NA	3)Narra Dhanalakshmi (Associate Professor)
(33) Name of priority country	:NA	4)J. L.V. Ramana Kumari (Assistant Professor)
(86) International Application No	:PCT//	5)K Jyostna (Assistant Professor)
Filing Date	:01/01/1900	(72)Name of Inventor :
(87) International Publication No	: NA	1)Dr. D. M. K. Chaitanya (Associate Professor)
(61) Patent of Addition to Application Number	:NA	2)Srilakshmi Aouthu (Associate Professor)
Filing Date	:NA	3)Narra Dhanalakshmi (Associate Professor)
(62) Divisional to Application Number	:NA	4)J. L.V. Ramana Kumari (Assistant Professor)
Filing Date	:NA	5)K Jyostna (Assistant Professor)

(57) Abstract :

ABSTRACT Our Invention I-Mobile Charger: Automatic Disconnect the Charger if Mobile Battery Status-97%.is to a smartphone wants battery supply to figure well. throughout the battery charging method, the state of charge may be inflated by up to 100-percent. One habit of charging batteries is to depart the smartphone connected to the charger all night long. Batteries that are already 100-percent however still connected to the charger can still receive an electrical current despite the fact that a tiny low price will cause a decrease in battery life and sturdiness. This invention is to make associate degree automatic battery charging system supported the automaton package. The results of this method are once proportion the share limit that we've got set is that the same because the percentage of the battery on the smartphone, the system can mechanically bring to an end the incoming current in order that the charging method can stop. The method is intended employing a microcontroller, Bluetooth module, relay module, automaton apps, associate degreed smartphone with an automaton package. The tests are the quality of the apps with the smartphone, the charging and discharging conditions on the system, and automatic battery charging. From the results of the tests, the system will cut the present to a price of zero amperes from the charger manually and mechanically controlled through the apps, the apps may be used on smartphones that have automaton version a pair of.1 or higher.

No. of Pages : 16 No. of Claims : 6

(54) Title of the invention : Experimental Investigation on Performance of Passive Direct Methanol Fuel Cell using Taper Cylindrical Openings on Current Collectors.

(51) International classification	:H01M0008101100, H01M0004660000, H01M0008041860, H01M0004700000, H01M0008024700	(71) Name of Applicant : 1)N V Raghavaiah (Research Scholar) Address of Applicant :Department of Mech Engineering, (NIT)National Institute of Technology Campus, Fathimanagar, Telangana 506004, India. Telangana India
(31) Priority Document No	:NA	2)Dr. G Naga Srinivasulu (Associate Professor)
(32) Priority Date	:NA	(72) Name of Inventor :
(33) Name of priority country	:NA	1)N V Raghavaiah (Research Scholar)
(86) International Application No	:PCT//	2)Dr. G Naga Srinivasulu (Associate Professor)
Filing Date	:01/01/1900	
(87) International Publication No	: NA	
(61) Patent of Addition to Application Number	:NA	
Filing Date	:NA	
(62) Divisional to Application Number	:NA	
Filing Date	:NA	

(57) Abstract :

ABSTRACT Our Invention Experimental Investigation on Performance of Passive Direct Methanol Fuel Cell using Taper Cylindrical Openings on Current Collectors is to a Current Collectors (CC) design plays an important role in performance optimization of Passive Direct Methanol Fuel Cell (pDMFC) with the desirable properties of low electrical resistivity, high thermal conductivity and more durability in methanol environment. More weight of current collectors and difficulty in removal of generated reaction products are important hindrances in the contemporary pDMFC. These two aspects, i.e., reduction of current collectors™ weight and carbon dioxide (CO₂) scavenging, are tackled in this paper by modifying the present design of uniform cylindrical openings to taper cylindrical openings. In this experimental study, Austenitic Stainless Steel Grade 316L has been selected as current collector material. Two types of current collector pairs are fabricated with 2 mm thick sheet, first one with taper cylindrical (frustum of cone) cross section having openings of 5.10 mm diameter on one side and 3.80 mm diameter on other side, and the second pair with uniform cylindrical cross section with 3.80 mm diameter openings with an opening ratio of 45.36%. Experiments are conducted at varying concentrations of methanol solution to study the performance of the cell. During the experiment, it is observed that the CO₂ is getting expelled easily from taper cylindrical openings than that of uniform cylindrical openings. Polarization curves and power density curves are drawn for comparison of performance of these current collectors. The best power density obtained using taper cylindrical opening current collectors at a methanol concentration of 3M is 7.056 mWcm⁻², whereas it is observed to be 5.219 mWcm⁻² in case of uniform cylindrical openings at the same 3M methanol concentration. Hence the taper cylindrical openings are found performing better at 3M concentration than that of cylindrical openings by 35.19 % at its best power density point and further the theoretical weight of the current collectors is also got reduced by 7.5% leading to improvement in gravitational power density.

No. of Pages : 26 No. of Claims : 6

(54) Title of the invention : ARTIFICIAL INTELLIGENCE BASED CONSTRUCTION OF MECHANICALLY DEVELOPED MACHINE MOTION PREDICTION SYSTEM TO REDUCE WORKSITE HAZARDS

<p>(51) International classification</p> <p>(31) Priority Document No</p> <p>(32) Priority Date</p> <p>(33) Name of priority country</p> <p>(86) International Application No Filing Date</p> <p>(87) International Publication No</p> <p>(61) Patent of Addition to Application Number Filing Date</p> <p>(62) Divisional to Application Number Filing Date</p>	<p>(71)Name of Applicant :</p> <p>1)Dr. K. Arun Vasantha Geethan, St. Joseph's Institute of Technology Address of Applicant :Professor and Head, Department of Mechanical Engineering, St. Joseph's Institute of Technology, A3-303, Valencia Apartment, Egattur, natham link road, Navalur, Chennai-603103 TamilNadu Mobile No: 9345032982 Mail id :kavgeeth@gmail.com Tamil Nadu India</p> <p>2)Dr.D.Sengeni, CK College of Engineering and Technology</p> <p>3)Dr.Sridevi Arumugam, Adithya Institute of Technology</p> <p>4)Dr.Lanitha.B, Karpagam Academy of Higher Education</p> <p>5)Venkataraman.K, KGiSL Institute of Technology</p> <p>6)Rajat Srivastava, University of Petroleum and Energy Studies</p> <p>7)Dr. Chandrashekar K., SJB Institute of Tech</p> <p>8)Dr. Shivappa H.A., Dr. Ambedkar Institute of Technology</p> <p>9)Dr. Pavithra G, Dayananda Sagar College of Engg. (DSCE)</p> <p>10)Dr.L.Jerin Leno, DMI St John The Baptist University</p> <p>11)Dr. Glorindal Selvam, DMI St John The Baptist University</p> <p>12)M. Sathish Kumar, Hindusthan College of Engineering & Technology</p> <p>13)P.Kaviya Priya, Hindusthan College of Engineering and Technology</p> <p>14)T.Sakthi Sree, Hindusthan College of Engineering and Technology</p> <p>(72)Name of Inventor :</p> <p>1)Dr. K. Arun Vasantha Geethan, St. Joseph's Institute of Technology</p> <p>2)Dr.D.Sengeni, CK College of Engineering and Technology</p> <p>3)Dr.Sridevi Arumugam, Adithya Institute of Technology</p> <p>4)Dr.Lanitha.B, Karpagam Academy of Higher Education</p> <p>5)Venkataraman.K, KGiSL Institute of Technology</p> <p>6)Rajat Srivastava, University of Petroleum and Energy Studies</p> <p>7)Dr. Chandrashekar K., SJB Institute of Tech</p> <p>8)Dr. Shivappa H.A., Dr. Ambedkar Institute of Technology</p> <p>9)Dr. Pavithra G, Dayananda Sagar College of Engg. (DSCE)</p> <p>10)Dr.L.Jerin Leno, DMI St John The Baptist University</p> <p>11)Dr. Glorindal Selvam, DMI St John The Baptist University</p> <p>12)M. Sathish Kumar, Hindusthan College of Engineering & Technology</p> <p>13)P.Kaviya Priya, Hindusthan College of Engineering and Technology</p> <p>14)T.Sakthi Sree, Hindusthan College of Engineering and Technology</p>
--	--

(57) Abstract :

Construction sites are anguish from high hazard rates amongst all workplaces, making it a foremost anxiety to progress the on-site safety. The risky operation of construction machines is an important reason of fatal hazards happened on construction sites. This invention, motion data (i.e. locations, poses and movements) of each machine have been taken for activity recognition and machine pose prediction. Motion data can be understood by processing the collected signals using different algorithms depending on the purpose. Object detection models such as Faster R-CNN can be used for detecting machine locations while object tracking models such as Tracking-learning-detection can be applied for machine tracking. In terms of machine keypoints, methods are anticipated constructed on deep learning models for human-pose estimation models such as Cascaded Pyramid Network. Later on, the predictable activity information is then merged with historical pose data to predict future machine poses over a type of recurrent neural network (RNN), so-called Gated Recurrent Unit (GRU).

No. of Pages : 14 No. of Claims : 3

(12) PATENT APPLICATION PUBLICATION

(21) Application No.202141024128 A

(19) INDIA

(22) Date of filing of Application :31/05/2021

(43) Publication Date : 11/06/2021

(54) Title of the invention : Novel process for the preparation of (R)-3-(4-(7H-Pyrrolo[2,3-d] pyrimidin-4-yl)-1H-pyrazol-1-yl)-3-cyclopentylpropanenitrile phosphate

(51) International classification	:C07D0487040000, A61K0031519000, C08K0003320000, C07D0403040000, C01B0025450000	(71) Name of Applicant : 1)Acebright (India) Pharma Pvt. Ltd. Address of Applicant :116/117 KIADB Industrial Area Jigani, Bangalore Karnataka India 560 105 Karnataka India
(31) Priority Document No	:NA	(72) Name of Inventor :
(32) Priority Date	:NA	1)Mr. Rajeev Venkatesh Jahagirdar
(33) Name of priority country	:NA	2)Mr. S Syed Ibrahim
(86) International Application No	:PCT//	
Filing Date	:01/01/1900	
(87) International Publication No	: NA	
(61) Patent of Addition to Application Number	:NA	
Filing Date	:NA	
(62) Divisional to Application Number	:NA	
Filing Date	:NA	

(57) Abstract :

The present invention is related to a processes for preparing a (R)-3-(4- (7H-pyrrolo[2,3d-] pyrimidin-4-yl)- 1 H-pyrazol- 1 -yl)-3-cyclopentylpropanenitrile phosphate, and related synthetic intermediate compounds. This novel process for the preparation of Ruxolitinib phosphate is cost-effective and is suitable for industrial production. The Ruxolitinib phosphate is represented by following structural Formula-I.

No. of Pages : 21 No. of Claims : 9

(12) PATENT APPLICATION PUBLICATION

(21) Application No.202141024267 A

(19) INDIA

(22) Date of filing of Application :31/05/2021

(43) Publication Date : 11/06/2021

(54) Title of the invention : A METHOD OF NON-CONTACT HERMETIC SEALING OF LTCC MODULES WITH PULSED LASER

(51) International classification	:H01L0023100000, H01R0013520000, H01L0023580000, H01L0021500000, H01L0021480000	(71) Name of Applicant : 1)Indian Space Research Organisation Address of Applicant :Department of Space, Antariksh Bhavan, New BEL Road, Bangalore, India Karnataka India
(31) Priority Document No	:NA	(72) Name of Inventor :
(32) Priority Date	:NA	1)Shivendra Tripathi
(33) Name of priority country	:NA	2)Sakaram Srinivasulu
(86) International Application No	:PCT//	3)Punam Pradeep Kumar
Filing Date	:01/01/1900	4)Apurba N. Bhattachrya
(87) International Publication No	: NA	
(61) Patent of Addition to Application Number	:NA	
Filing Date	:NA	
(62) Divisional to Application Number	:NA	
Filing Date	:NA	

(57) Abstract :

The embodiments herein provide a method of Non-contact Hermetic Sealing of LTCC modules. The method comprising mounting a LTCC Substrate assembly over alloy carrier with epoxy for handling or fastening purposes. Further, the method includes soldering the Multilayer LTCC substrate with a seal ring having individual walls for electromagnetic isolation. Further, the method includes placing a Cover lid over the Seal ring such that a mechanical interface of the seal ring and the cover lid joint fit-up and forms uniform plane surface. Further, the method includes performing a non-contact pulsed based LASER sealing at the mechanical interface of the seal ring and the cover lid to seal the seal ring and the cover lid to create hermetically sealed LTCC module. The sealing is performed inside a controlled glovebox with inert environment to create the hermetically sealed LTCC module.

No. of Pages : 25 No. of Claims : 10

(54) Title of the invention : System and Method to Detect Fake Profiles in Social Media

<p>(51) International classification</p> <p>(31) Priority Document No</p> <p>(32) Priority Date</p> <p>(33) Name of priority country</p> <p>(86) International Application No Filing Date</p> <p>(87) International Publication No</p> <p>(61) Patent of Addition to Application Number Filing Date</p> <p>(62) Divisional to Application Number Filing Date</p>	<p>:G06Q0050000000, H04L0029080000, H04L0012580000, G06Q0030020000, H04L0029060000</p> <p>:NA</p> <p>:NA</p> <p>:NA</p> <p>:PCT// :01/01/1900</p> <p>: NA</p> <p>:NA :NA</p> <p>:NA :NA</p>	<p>(71)Name of Applicant :</p> <p>1)Dr.Nirmala C R Address of Applicant :Professor and Head, Dept.of Computer Science and Engineering, Bapuji Institute of Engineering and Technology, #325, Shamanur Road, Davangere -577004, Karnataka, India Karnataka India</p> <p>2)Dr. R. Jagadeesh Kannan</p> <p>3)Dr. Sudhir Kumar Sharma</p> <p>4)Dr. J. Jeyapriya</p> <p>5)Dr Satish Rupraoji Billewar</p> <p>6)Dr. Anirban Mitra</p> <p>7)Dr. Anirban Das</p> <p>8)Mr.Mohammed Firdos Alam Sheikh</p> <p>9)Dr Vaneet Kumar</p> <p>10)Dr. Ansuman Sahoo</p> <p>11)Dr. Mohd Naved</p> <p>12)Sanjeev Kumar Singh</p> <p>13)Ravi Shanker Pathak</p> <p>14)Dr.S.Balamurugan</p> <p>(72)Name of Inventor :</p> <p>1)Dr.Nirmala C R</p> <p>2)Dr. R. Jagadeesh Kannan</p> <p>3)Dr. Sudhir Kumar Sharma</p> <p>4)Dr. J. Jeyapriya</p> <p>5)Dr Satish Rupraoji Billewar</p> <p>6)Dr. Anirban Mitra</p> <p>7)Dr. Anirban Das</p> <p>8)Mr.Mohammed Firdos Alam Sheikh</p> <p>9)Dr Vaneet Kumar</p> <p>10)Dr. Ansuman Sahoo</p> <p>11)Dr. Mohd Naved</p> <p>12)Sanjeev Kumar Singh</p> <p>13)Ravi Shanker Pathak</p> <p>14)Dr.S.Balamurugan</p>
--	---	---

(57) Abstract :

The System and Methods to Detect Fake Profiles in Social Media (SMDFP) helps the social media organization can make use of the SMDFP to match the new user with existing user details and activities to identify whether the new user is fake or not. The user database is used to store all the user account details in the database. User friends list is the number of friends in his/her contact list. The chat history can contain the time of chat and content of chat to a specific friend. The user account details give the full information about the user and the IP address provides where the user normally connected with which device. User profile photo and photo gallery helps to analyze the multimedia communication between the friend's list. Cloud storage provides the facility to store all social media information in the cloud for centralized access. The above-mentioned information is matched with existing user profiles with a new user profile to compare their similarity. If similarity exists then the new user profile will assign a similarity score. The process gets continued up until to score reaches the threshold value. Once the score reaches the threshold value then the new user profile will automatically be blocked. The SMDFP control unit helps to monitoring and managing the successful functioning of the whole SMDFP system. By using this SMDFP, the social media organization can make use of the SMDFP to match the new user with existing user details and activities to identify whether the new user is fake or not.

No. of Pages : 16 No. of Claims : 3

(12) PATENT APPLICATION PUBLICATION

(21) Application No.202141024309 A

(19) INDIA

(22) Date of filing of Application :01/06/2021

(43) Publication Date : 11/06/2021

(54) Title of the invention : AUTOMATIC CROP PREDICTOR

(51) International classification :G06N0020000000,
G01N0033240000,
G06N0003080000,
A01G0025160000,
G06Q0050020000

(31) Priority Document No :NA
(32) Priority Date :NA
(33) Name of priority country :NA
(86) International Application No :PCT//
Filing Date :01/01/1900
(87) International Publication No : NA
(61) Patent of Addition to Application Number :NA
Filing Date :NA
(62) Divisional to Application Number :NA
Filing Date :NA

(71)**Name of Applicant :**
1)Er. Abraham George
Address of Applicant :Assistant Professor Department of
Electrical and Electronics SAINTGITS College of Engineering,
Kottukulam Hills Pathamuttom P. O Kottayam 686532 KERALA
Kerala India
2)Margaret Sara Thomas

(72)**Name of Inventor :**
1)Er. Abraham George
2)Margaret Sara Thomas

(57) Abstract :

Artificial Intelligence (A.I) according to entrepreneurs is the future, giving the machines the power to take decisions with amount of coding. It is important to meet the food requirements of all the people. The selection of crops which can be grown over a given piece of land is important to produce maximum crops on the limited piece of land. Taking different parameters such as soil type, pH value, temperature, humidity, soil moisture into consideration and fed into the trained machine learning model to predict the suitable crop that can be grown on a piece of land.

No. of Pages : 11 No. of Claims : 4

(54) Title of the invention : MULTI-BAND RECONFIGURABLE AND FLEXIBLE ANTENNA

(51) International classification	:H01Q0001480000, H01Q0001380000, H01Q0009420000, H01Q0009300000, H01Q0009400000	(71) Name of Applicant : 1)M N V S S Kumar Address of Applicant :Department of Electronics and Communication Engineering, Aditya Institute of Technology and Management, Tekkali, Srikakulam-532201, Andhra Pradesh, India Andhra Pradesh India
(31) Priority Document No	:NA	2)Koduri Sreelakshmi
(32) Priority Date	:NA	3)Gottapu Sasibhushana Rao
(33) Name of priority country	:NA	(72) Name of Inventor :
(86) International Application No	:PCT//	1)M N V S S Kumar
Filing Date	:01/01/1900	2)Koduri Sreelakshmi
(87) International Publication No	: NA	3)Gottapu Sasibhushana Rao
(61) Patent of Addition to Application Number	:NA	
Filing Date	:NA	
(62) Divisional to Application Number	:NA	
Filing Date	:NA	

(57) Abstract :

Embodiments of the present disclosure provide a multi-band reconfigurable and flexible antenna (100). The multi-band reconfigurable and flexible antenna comprising a substrate (110). The substrate comprising a monopole patch (106) connected to a feedline (112), wherein corners of the monopole patch are truncated on a left side and a U-shaped slot is cut on the monopole patch at a right side for better impedance matching; an inverted L-shaped monopole (114) connected to the monopole patch; an F-shaped monopole (116) connected to the monopole patch; at least two PIN diode switches (102, 104), wherein a first PIN diode switch (102) of the at least two PIN diode switches is embedded between the monopole patch and the F-shaped monopole, wherein a second PIN diode switch (104) of the at least two PIN diode switches is embedded between the monopole patch and the inverted L-shaped monopole to provide flexible frequency reconfigurable performance; and one or more ground planes (108)..The antenna is fed by the grounded asymmetric coplanar strip (GACS) feed 112, where a grounded asymmetric coplanar strip (GACS) is a modification of an ACS and the additional ground plane 108 is used on the back of the substrate 110 and the bottom ground plane 108 is spaced 1.53 mm beneath the top ground to decrease backward radiation.

No. of Pages : 28 No. of Claims : 10

(12) PATENT APPLICATION PUBLICATION

(21) Application No.202141024377 A

(19) INDIA

(22) Date of filing of Application :01/06/2021

(43) Publication Date : 11/06/2021

(54) Title of the invention : Printed patch antenna with fractal geometry for low band 5G frequencies ranging 25GHz to 35GHz

(51) International classification	:H01Q0009040000, H01Q0001380000, H01Q0021060000, H01Q0001360000, B82Y0040000000	(71)Name of Applicant : 1)Abdul Rahim Address of Applicant :First Floor, 79/A, Shivani Nagar Road no 2, Opposite to indane petrol pump Bandlaguda-Nagole, Hyderabad 500068 Telangana India 2)PRAVEEN KUMAR MALIK 3)Anurag Joshi 4)Mahesh Kumar Aghwariya 5)Manish Sharma 6)Pavan Kumar Shukla
(31) Priority Document No	:NA	(72)Name of Inventor : 1)Abdul Rahim 2)PRAVEEN KUMAR MALIK 3)Anurag Joshi 4)Mahesh Kumar Aghwariya 5)Manish Sharma 6)Pavan Kumar Shukla
(32) Priority Date	:NA	
(33) Name of priority country	:NA	
(86) International Application No	:PCT//	
Filing Date	:01/01/1900	
(87) International Publication No	: NA	
(61) Patent of Addition to Application	:NA	
Number	:NA	
Filing Date	:NA	
(62) Divisional to Application Number	:NA	
Filing Date	:NA	

(57) Abstract :

The invention relates to the design of a Microstrip patch antenna with fractal geometry suitable for the low band 5G frequencies ranging 25GHz to 35 GHz. The antenna is fabricated using Rogers RO 4003 dielectric material substrate with a thickness of 0.55mm, the dielectric constant (ϵ_r) of 3.55 and, loss tangent of 0.0027. The substrate dimensions are 50 x 38 x 0.55mm³, with a rectangular feed line. The ground is designed using the concept of recessed ground (defected) to achieve good stability. Antenna design is selected such a way that it can be used for applications such as vehicular communications, device to device communications, wide band applications and sensor networks. The antenna is designed and simulated using HFSS v15, fabricated using compact computer numerical control and tested using Agilent Technologies N5247A series 2-Port VNA available from 100KHz to 40GHz frequency.

No. of Pages : 14 No. of Claims : 8

(12) PATENT APPLICATION PUBLICATION

(21) Application No.202141024465 A

(19) INDIA

(22) Date of filing of Application :01/06/2021

(43) Publication Date : 11/06/2021

(54) Title of the invention : A VEHICLE SIMULATION TOOL BY PROVIDING WSN INSIDE THE VEHICLE WITH AI & ML BASED INTERFACES

(51) International classification	:G06N0020000000, B60W0050080000, B60W0050140000, H04W0084180000, A61B0005000000	(71)Name of Applicant : 1)Dr.Karthikeyan Palaniappan Address of Applicant :Associate Professor, Center for System Design, Chennai Institute of Technology, Chennai, Tamil Nadu, India. Pin Code:600069 Tamil Nadu India 2)Mr.Mahmad Ziya Gous 3)Dr.Vignesh Ramamoorthy H 4)Mr.Sandeep Srivastava 5)Mr.M.Rajkumar 6)Dr.A.Geetha 7)Mr.Tarun Jaiswal 8)Dr.K.Swathi 9)Dr.Sushma Jaiswal 10)Mr.Miranji Katta
(31) Priority Document No	:NA	(72)Name of Inventor : 1)Dr.Karthikeyan Palaniappan 2)Mr.Mahmad Ziya Gous 3)Dr.Vignesh Ramamoorthy H 4)Mr.Sandeep Srivastava 5)Mr.M.Rajkumar 6)Dr.A.Geetha 7)Mr.Tarun Jaiswal 8)Dr.K.Swathi 9)Dr.Sushma Jaiswal 10)Mr.Miranji Katta
(32) Priority Date	:NA	
(33) Name of priority country	:NA	
(86) International Application No	:PCT//	
Filing Date	:01/01/1900	
(87) International Publication No	: NA	
(61) Patent of Addition to Application Number	:NA	
Filing Date	:NA	
(62) Divisional to Application Number	:NA	
Filing Date	:NA	

(57) Abstract :

ABSTRACT A VEHICLE SIMULATION TOOL BY PROVIDING WSN INSIDE THE VEHICLE WITH AI & ML BASED INTERFACES [033] The present invention discloses a vehicle simulation system and tool by providing varied detection for driver with respect to physical and body vitals competency level to drive a vehicle with an Artificial Intelligence (AI) & Machine Learning (ML) based interfaces and method thereof. The vehicle simulation system and tool includes, but not limited to, a plurality of wireless sensors network (WSN) installed inside the vehicle; a display unit having a graphical user interface; a processing unit to receive input from the WSN and activate the other means which needs to be triggered according to the desired driving competency level and a driving seat comfortable level. Further, the processing unit evaluates the desired driving competency level and the driving seat comfortable level by using the trained data through the Artificial Intelligence (AI) & Machine Learning (ML) based interfaces. Accompanied Drawing [FIG. 1]

No. of Pages : 20 No. of Claims : 9

(12) PATENT APPLICATION PUBLICATION

(21) Application No.202141024477 A

(19) INDIA

(22) Date of filing of Application :01/06/2021

(43) Publication Date : 11/06/2021

(54) Title of the invention : A NOVEL LC-MS METHOD FOR SIMULTANEOUS ESTIMATION OF OLMESARTAN MEDOXOMIL AND AMILODIPINE BESYLATE

(51) International classification	:A61K0031442200, A61K0031417800, G01N0030340000, C12Q0001180000, G01N0033558000	(71) Name of Applicant : 1)Dr. SONIA K Address of Applicant :SRM COLLEGE OF PHARMACY, SRM IST, SRM NAGAR, KATTANKULATHUR-603203, CHENGALPATTU, TAMIL NADU, INDIA Tamil Nadu India
(31) Priority Document No	:NA	2)Dr. M.N. NAPPINNAI
(32) Priority Date	:NA	3)Dr. MANIKANDAN K
(33) Name of priority country	:NA	4)Dr. SAROJ YADAV
(86) International Application No	:PCT//	5)Dr. Om Prakash
Filing Date	:01/01/1900	(72) Name of Inventor :
(87) International Publication No	: NA	1)Dr. SONIA K
(61) Patent of Addition to Application Number	:NA	2)Dr. M.N. NAPPINNAI
Filing Date	:NA	3)Dr. MANIKANDAN K
(62) Divisional to Application Number	:NA	4)Dr. SAROJ YADAV
Filing Date	:NA	5)Dr. Om Prakash

(57) Abstract :

The present innovation relates to develop a simple, rapid and sensitive stability indicating method for simultaneous estimation of analytes (Olmesartan medoxomil and Amlodipine besylate) as an active pharmaceutical ingredient in bulk drug and fixed dose formulation using Liquid Column-Mass Spectrometry (LC-MS) methods. The innovative method is successfully conducted a forced degradation study on Olmesartan medoxomil and Amlodipine besylate to determine the percentage degradation under respective stress condition. The developed cost-effective method can be used by testing laboratory for the quantitative analysis of two drugs simultaneously with high degree of accuracy and precision.

No. of Pages : 17 No. of Claims : 10

(12) PATENT APPLICATION PUBLICATION

(21) Application No.202141024577 A

(19) INDIA

(22) Date of filing of Application :02/06/2021

(43) Publication Date : 11/06/2021

(54) Title of the invention : A METHOD AND SYSTEM FOR OBSTACLE DETECTION USING SMART WALKING STICK FOR BLIND AND VISUALLY IMPAIRED PERSONS

(51) International classification	:A61H0003060000, G08B0021020000, G09B0021000000, G01S0015930000, A45B0003000000	(71) Name of Applicant : 1)Dr. S. Pravinth Raja Address of Applicant :Associate Professor Department of CSE Presidency University Yelahanka Bangalore, Karnataka Karnataka India
(31) Priority Document No	:NA	2)Dr.C. Kalaiarasan
(32) Priority Date	:NA	3)Ms.R.Sapna
(33) Name of priority country	:NA	(72) Name of Inventor :
(86) International Application No	:PCT//	1)Dr. S. Pravinth Raja
Filing Date	:01/01/1900	2)Dr.C. Kalaiarasan
(87) International Publication No	: NA	3)Ms.R.Sapna
(61) Patent of Addition to Application Number	:NA	
Filing Date	:NA	
(62) Divisional to Application Number	:NA	
Filing Date	:NA	

(57) Abstract :

ABSTRACT A METHOD AND SYSTEM FOR OBSTACLE DETECTION USING SMART WALKING STICK FOR BLIND AND VISUALLY IMPAIRED PERSONS Aspects of the present disclosure relate a method (100) for obstacle detection (102) using smart walking stick system (200) for blind and visually impaired persons. The said system includes an obstacle avoidance module (202) for detecting obstacles, the obstacle avoidance module (202) includes an infrared obstacle avoidance unit (204) for detecting narrow passageways and steps and an ultrasonic ranging obstacle avoidance unit (206) for surveying barrier of distance and show roadblock distance condition. A help seeking module (208) is used for carrying out voice help seeking on nearby people, the help seeking module (208) includes a voice help seeking module (208) unit and a remote communication help seeking unit. A GPS (210) module is used for sending positioning information and speed information of the smart walking stick system (200) to a cloud server database through a GPRS (212) communication module for storage. A WhatsApp small program unit (216) for monitoring the operation terminal by a guardian of the blind person. A core module (214) including a nine-axis accelerometer gyro sensor (MPU6050) and a temperature sensor. We also have the method (100) of detection described in the invention. (FIG. 1 will be the reference figure)

No. of Pages : 22 No. of Claims : 5

(12) PATENT APPLICATION PUBLICATION

(21) Application No.202141024580 A

(19) INDIA

(22) Date of filing of Application :02/06/2021

(43) Publication Date : 11/06/2021

(54) Title of the invention : AN IMPROVED PROCESS FOR THE PREPARATION OF DIBENZO DIAZEPINE DERIVATIVE

(51) International classification	:A61K0031551300, A61K0031415000, C01B0013180000, A61K0031421000, A01N0025340000	(71) Name of Applicant : 1)GLOBAL CALCIUM PVT. LTD. Address of Applicant :125 & 126, Sipcot Industrial complex, Hosur. Tamil Nadu India
(31) Priority Document No	:NA	(72) Name of Inventor :
(32) Priority Date	:NA	1)VAZIRALLY SAHIL
(33) Name of priority country	:NA	2)YADAVALLI SUNEEL KUMAR
(86) International Application No	:PCT// /	3)CHANGALARAYA DASARADHAN
Filing Date	:01/01/1900	4)NAVANEETHA KRISHNAN GANESAN
(87) International Publication No	: NA	5)SARAVANAN MOHAN KUMAR
(61) Patent of Addition to Application Number	:NA	
Filing Date	:NA	
(62) Divisional to Application Number	:NA	
Filing Date	:NA	

(57) Abstract :

The present invention relates to an improved process for the preparation of Clozapine of formula-1 which is simple, safe, economic, eco-friendly process and suitable on commercial scale with high reproducibility. Formula-1

No. of Pages : 26 No. of Claims : 6

(12) PATENT APPLICATION PUBLICATION

(21) Application No.202141024596 A

(19) INDIA

(22) Date of filing of Application :02/06/2021

(43) Publication Date : 11/06/2021

(54) Title of the invention : SYSTEM OF MATHEMATICAL MODELLING OF NEW THEORY OF SOCIAL INTELLIGENCE

(51) International classification	:G06Q0050000000, A61K0039000000, G16C0020300000, G06Q0010060000, B25J0009160000	(71) Name of Applicant : 1)Dr. Sameer Babu M Address of Applicant :Assistant Professor, Department of Education, University of Kerala , Thiruvananthapuram, Kerala, India Kerala India
(31) Priority Document No	:NA	2)Dr. Sarwat Ali
(32) Priority Date	:NA	3)Prof. Riaz Shakir Khan
(33) Name of priority country	:NA	(72) Name of Inventor :
(86) International Application No	:PCT//	1)Dr. Sameer Babu M
Filing Date	:01/01/1900	2)Dr. Sarwat Ali
(87) International Publication No	: NA	3)Prof. Riaz Shakir Khan
(61) Patent of Addition to Application Number	:NA	
Filing Date	:NA	
(62) Divisional to Application Number	:NA	
Filing Date	:NA	

(57) Abstract :

The present invention relates to system of mathematical modelling of new theory of social intelligence. The objective of the present invention is to solve the problems in the prior art technologies related to social behavior analysis using computer mathematical model.

No. of Pages : 30 No. of Claims : 3

(12) PATENT APPLICATION PUBLICATION

(21) Application No.202141024665 A

(19) INDIA

(22) Date of filing of Application :03/06/2021

(43) Publication Date : 11/06/2021

(54) Title of the invention : A LOW-COST PORTABLE DEVICE FOR EVALUATING STRETCH FORMABILITY AT VARYING TEMPERATURES AND STRAIN-PATHS

(51) International classification	:F27D0011020000, G01N0027120000, G01N0025000000, G01N0011040000, G01N0003080000	(71) Name of Applicant : 1)INDIAN INSTITUTE OF TECHNOLOGY MADRAS (IIT MADRAS) Address of Applicant :The Dean, Industrial Consultancy & Sponsored Research [IC&SR], Indian Institute of Technology Madras, Sardar Patel Road, IITP.O, Chennai, Tamil Nadu, India, Pincode -600036 Tamil Nadu India
(31) Priority Document No	:NA	(72) Name of Inventor :
(32) Priority Date	:NA	1)RAKESH KUMAR
(33) Name of priority country	:NA	2)DR. SUSHANTA KUMAR PANIGRAHI
(86) International Application No	:PCT//	
Filing Date	:01/01/1900	
(87) International Publication No	: NA	
(61) Patent of Addition to Application Number:	NA	
Filing Date	:NA	
(62) Divisional to Application Number	:NA	
Filing Date	:NA	

(57) Abstract :

A low-cost portable device for evaluating stretch formability at varying temperatures and strain-paths, is disclosed herein. The device (100) comprises a die (08), a punch (18), a sample holder, an electrical resistance technology-based heater plate (11), a gearbox (19), thrust bearing (20), guides (02), guide pillars (01 and 16), slider plates (06, 09 and 14), heat insulating rings (07, and 10), ceramic tube (12), bushings (03 and 04), a handle drive (05), a bed (17) and sensors (temperature) at the heating coil (25), a load cell (15), load cell and digital indicators (27, 28 and 29). The device has capability to test sample width of various sizes ranging from 3 mm to 70 mm and thickness between 0.2 mm to 2 mm. The gearbox (19) with worm drive arrangement makes it easier to operate manually with high precision. The horizontal design configuration makes the Digital Image Correlation (DIC) integration extremely easy and simple.

No. of Pages : 22 No. of Claims : 6

(12) PATENT APPLICATION PUBLICATION

(21) Application No.202141024721 A

(19) INDIA

(22) Date of filing of Application :03/06/2021

(43) Publication Date : 11/06/2021

(54) Title of the invention : A NOVEL GRAPHICAL AUTHENTICATION METHOD TO MITIGATE SHOULDER SURFING ASSAULT

(51) International classification	:H04L0029060000, G06F0021360000, G06F0021310000, H04L0009320000, G06Q0020120000	(71) Name of Applicant : 1)Norman Dias Address of Applicant :(Research Scholar), CSE Department, School of Engineering, Dayananda Sagar University, Devarakaggalahalli, Harohalli, Kanakapura Road, Bengaluru. Karnataka India
(31) Priority Document No	:NA	2)Dr Reeja S R
(32) Priority Date	:NA	(72) Name of Inventor :
(33) Name of priority country	:NA	1)Norman Dias
(86) International Application No	:PCT//	2)Dr Reeja S R
Filing Date	:01/01/1900	
(87) International Publication No	: NA	
(61) Patent of Addition to Application Number	:NA	
Filing Date	:NA	
(62) Divisional to Application Number	:NA	
Filing Date	:NA	

(57) Abstract :

ABSTRACT A novel graphical authentication method based on recall and recognition in the area of Human- Computer- Interaction (HCI), which is based on Data mining (DM) and Image processing (IP) techniques, provides the user with a different set of unique and dynamic password every time the user is authenticated by the system, in an interactive environment, also the system does not burden the human brain in memorizing difficult passwords across various online accounts, the created password cannot be verbally described nor written down on a piece of paper . The system can be effectively integrated on the latest touch screen devices as well on existing web based terminals. The (HCI) based system further increases the password space in comparison to any traditional graphical authentication methods and also mitigates the risk of shoulder surfing attack that could be carried out either physically or automated.

No. of Pages : 13 No. of Claims : 9

(12) PATENT APPLICATION PUBLICATION

(21) Application No.202141024729 A

(19) INDIA

(22) Date of filing of Application :03/06/2021

(43) Publication Date : 11/06/2021

(54) Title of the invention : ARTIFICIAL UMPIRING SYSTEM EMBEDDED IN CRICKET STUMP

(51) International classification	:A63B0071060000, A63B0102200000, A63F0013213000, H04N0021218700, A63F0013870000	(71) Name of Applicant : 1)Dr. Shermin S Address of Applicant :Amjad Bhavan, Nalumukku, Mankamkuzhy P.O, Mavelikara-690558 Kerala India 2)Ajesh F 3)Binu Dennis 4)Rajakumar B. R.
(31) Priority Document No	:NA	(72) Name of Inventor : 1)Dr. Shermin S 2)Ajesh F 3)Binu Dennis 4)Rajakumar B. R.
(32) Priority Date	:NA	
(33) Name of priority country	:NA	
(86) International Application No	:PCT//	
Filing Date	:01/01/1900	
(87) International Publication No	: NA	
(61) Patent of Addition to Application Number	:NA	
Filing Date	:NA	
(62) Divisional to Application Number	:NA	
Filing Date	:NA	

(57) Abstract :

The main purpose of this present invention is to perform the role of an umpire by using Artificial Umpiring System (AUS). In this present invention, the AUS is embedded within the stump to inform the score and condition of the game to the audience and players. Initially, the camera starts to capture the live video of the cricket to check playersTM movement, and the microphone records the audio signal and vibration signal. Then, the captured information will be processed in the processing system and produce the output in speech format and light format. The lighting system is placed at the bottom of the cricket stump, in which the light will be glowing as red for negative comment and green for the positive comment. The target scores, current scores, required run rate, wickets, boundaries, remaining over, etc., will be displayed on the scoreboard. [To be published with Figure.1]

No. of Pages : 19 No. of Claims : 6

(12) PATENT APPLICATION PUBLICATION

(21) Application No.202141024734 A

(19) INDIA

(22) Date of filing of Application :03/06/2021

(43) Publication Date : 11/06/2021

(54) Title of the invention : SMART HELMET WITH BIKE SYSTEM FOR SAFETY TRANSPORTATION

(51) International classification	:A42B0003040000, G08B0021040000, A42B0003300000, A41D0013018000, H04W0088060000	(71)Name of Applicant : 1)Mr. DILEEP J Address of Applicant :Designation: Assistant Professor Department: Electronics and Telecommunication Engineering Institution address: K. S. Institute of Technology, No.14, Raghuvanahalli, Kanakpura road, Bengaluru-560109 Email id: dileepj@ksit.edu.in Mobile No: 8867781213 Karnataka India
(31) Priority Document No	:NA	2)Dr. Chanda V Reddy
(32) Priority Date	:NA	3)Dr. Devika B
(33) Name of priority country	:NA	4)Mrs. V Sangeetha
(86) International Application No	:PCT//	5)Mr. Praveen A
Filing Date	:01/01/1900	6)Apoorva PM
(87) International Publication No	: NA	7)Rachana Giliyal
(61) Patent of Addition to Application	:NA	8)Sahana R
Number	:NA	9)Dr. Chethana Sridhar
Filing Date	:NA	(72)Name of Inventor :
(62) Divisional to Application Number	:NA	1)Mr. DILEEP J
Filing Date	:NA	2)Dr. Chanda V Reddy
		3)Dr. Devika B
		4)Mrs. V Sangeetha
		5)Mr. Praveen A
		6)Apoorva PM
		7)Rachana Giliyal
		8)Sahana R
		9)Dr. Chethana Sridhar

(57) Abstract :

ABSTRACT Smart helmet • looks like a normal helmet, but it consists of some remarkable sensors, networks with communication modules, which helps to stop the drive or not to allow the driving at the critical or abnormal situations. The distinctive utility of this Invention is fall detection, if the bike rider falls from the bike, it will send message to the registered phone numbers impulsively. The Invention discloses a smart helmet capable of alerting rider in critical situations and alerting family members or emergency numbers in case of accident. The Invention tries to address the issues on Riders safety on roads.

No. of Pages : 12 No. of Claims : 1

(12) PATENT APPLICATION PUBLICATION

(21) Application No.202141024795 A

(19) INDIA

(22) Date of filing of Application :03/06/2021

(43) Publication Date : 11/06/2021

(54) Title of the invention : SYSTEM FOR CLOUD COMPUTING FRAMEWORK BASED ON VISUAL DATA MINING ARCHITECTURE

(51) International classification	:G06F0016245800, G06N0003080000, G06F0016260000, G06F0009455000, H04L0029080000	(71)Name of Applicant : 1)DR.D.SENTHIL Address of Applicant :Head & Assistant Professor, Department of Computer Science (Shift II) , Nazareth College of Arts and Science, Chennai, India Tamil Nadu India 2)DR.S.ELAVARASI 3)DR.A.VINOTH 4)DR.MEGALA R 5)DR.V.UMADEVI 6)DR.SREEJITH VIGNESH B P 7)P.AMUTHA 8)DR.K.MUNUSAMY 9)KAVIYARASI R
(31) Priority Document No	:NA	(72)Name of Inventor : 1)DR.D.SENTHIL 2)DR.S.ELAVARASI 3)DR.A.VINOTH 4)DR.MEGALA R 5)DR.V.UMADEVI 6)DR.SREEJITH VIGNESH B P 7)P.AMUTHA 8)DR.K.MUNUSAMY 9)KAVIYARASI R
(32) Priority Date	:NA	
(33) Name of priority country	:NA	
(86) International Application No	:PCT//	
Filing Date	:01/01/1900	
(87) International Publication No	: NA	
(61) Patent of Addition to Application Number	:NA	
Filing Date	:NA	
(62) Divisional to Application Number	:NA	
Filing Date	:NA	

(57) Abstract :

The present invention relates to system for cloud computing framework based on visual data mining architecture. The objective of the present invention is to solve the problems in the prior art technologies related to data mining architecture for cloud computing.

No. of Pages : 28 No. of Claims : 4

(12) PATENT APPLICATION PUBLICATION

(21) Application No.202141024812 A

(19) INDIA

(22) Date of filing of Application :03/06/2021

(43) Publication Date : 11/06/2021

(54) Title of the invention : CLOUD BASED SECURED DATA TRANSMISSION USING TRAPDOOR ENCRYPTION

(51) International classification	:H04L0009080000, H04L0009320000, H04L0009300000, H04L0029060000, G06F0021620000	(71)Name of Applicant : 1)Mrs. THIRUPURASUNDARI D R Address of Applicant :ASSISTANT PROFESSOR DEPARTMENT OF COMPUTER SCIENCE ENGINEERING MEENAKSHI COLLEGE OF ENGINEERING NO-12, VEMBULIAMMAN KOIL STREET, WEST K.K NAGAR, CHENNAI - 600 078. Tamil Nadu India 2)Dr. SUMA SIRA JACOB 3)Dr A.HEMLATHADHEVI 4)Mrs. V. VIJAYALAKSHMI 5)Dr. K. ANAND 6)Ms.R.PAVAIYARKARASI 7)Mr.C RAMESH KUMAR 8)Dr. DASARI KIRAN KUMAR 9)Mr. BISWADIP BASU MALLIK
(31) Priority Document No	:NA	(72)Name of Inventor : 1)Mrs. THIRUPURASUNDARI D R 2)Dr. SUMA SIRA JACOB 3)Dr A.HEMLATHADHEVI 4)Mrs. V. VIJAYALAKSHMI 5)Dr. K. ANAND 6)Ms.R.PAVAIYARKARASI 7)Mr.C RAMESH KUMAR 8)Dr. DASARI KIRAN KUMAR 9)Mr. BISWADIP BASU MALLIK
(32) Priority Date	:NA	
(33) Name of priority country	:NA	
(86) International Application No	:PCT//	
Filing Date	:01/01/1900	
(87) International Publication No	: NA	
(61) Patent of Addition to Application	:NA	
Number	:NA	
Filing Date	:NA	
(62) Divisional to Application Number	:NA	
Filing Date	:NA	

(57) Abstract :

ABSTRACT CLOUD BASED SECURED DATA TRANSMISSION USING TRAPDOOR ENCRYPTION Cloud administrations have become an amazing design to perform complex huge scope figuring errands and length a scope of IT capacities from capacity and calculation of information base and application administrations. Distributed computing has various good angles to address the fast development of financial aspects and innovative boundaries. While enlisting the subtleties, each client gets a public key and private key. Information proprietor creates set of hidden entryway keys and ABE key which are sent to the client. 3 - 4 Trapdoor keys are created and everybody is a couple of keys. At the point when worker creates one key client needs to give another pair of the keys. Any document content is covered up with any picture made stegano, the interaction steganography and shipped off the worker. Worker destegano the picture and afterward gets the other pair of the secret entryway key and checks for confirmation. After confirmation worker checks the entrance strategy for information access through ABE.

No. of Pages : 28 No. of Claims : 8

(12) PATENT APPLICATION PUBLICATION

(21) Application No.202141024843 A

(19) INDIA

(22) Date of filing of Application :04/06/2021

(43) Publication Date : 11/06/2021

(54) Title of the invention : AN INTELLECTUAL APPROACH FOR ENERGY PRESERVATION IN COMMUNAL LIGHTNING SCHEME USING IOT

(51) International classification	:G06Q0010060000, F21W0131103000, H02J0003460000, H02J0013000000, F24F0013300000	(71)Name of Applicant : 1)Dr. V. Muneeswaran Address of Applicant :Assistant Professor, Department of Electronics and Communication Engineering Kalasalingam Academy of Research And Education, Anand Nagar, Krishnankoil-626126, Tamil Nadu, India Tamil Nadu India
(31) Priority Document No	:NA	2)Dr. Kalpana Murugan
(32) Priority Date	:NA	3)Mr. S.Godwin
(33) Name of priority country	:NA	4)Mr. P.Gokul
(86) International Application No	:PCT//	5)Mr. T .Gokul
Filing Date	:01/01/1900	6)Mr. M. Jegatheswaran
(87) International Publication No	: NA	(72)Name of Inventor :
(61) Patent of Addition to Application Number	:NA	1)Dr. V. Muneeswaran
Filing Date	:NA	2)Dr. Kalpana Murugan
(62) Divisional to Application Number	:NA	3)Mr. S.Godwin
Filing Date	:NA	4)Mr. P.Gokul
		5)Mr. T .Gokul
		6)Mr. M. Jegatheswaran

(57) Abstract :

The energy conservation and energy reduction based upon the efficient utilization and accommodation of resources that are available provides the solution to the energy consumption . As we all know that the energy is divided into two types namely renewable and non-renewable energy resources as well. In which the renewable energy resources are which the present abundant in nature and can be used again and again when compared to the non-renewable energy resources as well. So the respective individual needs to take care about the energy saving modes and also the future generation to utilize it and leave it for the next and after. In this work an intelligent framework for effective control of street lighting system which is based on the concept of Availability on demand • is anticipated. The proposed system provides an competent scheme for energy conservation in public lighting system.

No. of Pages : 6 No. of Claims : 5

(12) PATENT APPLICATION PUBLICATION

(21) Application No.202141024918 A

(19) INDIA

(22) Date of filing of Application :04/06/2021

(43) Publication Date : 11/06/2021

(54) Title of the invention : Two Ways Water Faucet

(51) International classification	:E03C0001040000, E03C0001050000, E03C0001080000, F16K0011078000, A47J0031057000	(71) Name of Applicant : 1)Sujana Doniparthi Address of Applicant :2f, D Block, Vaikund Govardhan Apartments,Old ECR link Road, Shollinganallur,Chennai Tamil Nadu India
(31) Priority Document No	:NA	(72) Name of Inventor :
(32) Priority Date	:NA	1)Sujana Doniparthi
(33) Name of priority country	:NA	
(86) International Application No	:PCT//	
Filing Date	:01/01/1900	
(87) International Publication No	: NA	
(61) Patent of Addition to Application Number:	:NA	
Filing Date	:NA	
(62) Divisional to Application Number	:NA	
Filing Date	:NA	

(57) Abstract :

This invention is related to a water faucet that delivers water in two directions(one above and one below) from the tip of the spout. The water faucet includes a spout with a partition, dividing it into two channels. A valve is positioned at the beginning of the partition and is configured to be operated through a lever. Operation of the lever either downwards or upwards, causes the valve to operate resulting in delivery of the water through the water delivery outlet present below or above the tip of the spout.

No. of Pages : 17 No. of Claims : 3

(12) PATENT APPLICATION PUBLICATION

(21) Application No.202141024950 A

(19) INDIA

(22) Date of filing of Application :04/06/2021

(43) Publication Date : 11/06/2021

(54) Title of the invention : ADVANCE FACE MASK FOR COVID-19 PROTECTION USING ARTIFICIAL INTELLIGENCE WITH INTEGRATED QUALITY AND PROXIMITY DETECTION

<p>(51) International classification :H04W0004020000, A61L0027540000, A61K0008730000, A61M0016060000, G10L0021021600</p> <p>(31) Priority Document No :NA</p> <p>(32) Priority Date :NA</p> <p>(33) Name of priority country :NA</p> <p>(86) International Application No :PCT// Filing Date :01/01/1900</p> <p>(87) International Publication No : NA</p> <p>(61) Patent of Addition to Application Number :NA Filing Date :NA</p> <p>(62) Divisional to Application Number :NA Filing Date :NA</p>	<p>(71)Name of Applicant :</p> <p>1)Dr. Jitendranath Mungara Address of Applicant :Principal & Professor, Department of Computer Science and Engineering, Nagarjuna College of Engineering & Technology, Bangalore, Karnataka, India Karnataka India</p> <p>2)Dr. Muthukumar S</p> <p>3)Dr. Manoj Sharma</p> <p>4)Dr. Pooja Singh</p> <p>5)Dr Nandhagopal S Munusamy</p> <p>6)Dr. Ram Shringar Raw</p> <p>7)Mr. Gaurav Tripathi</p> <p>8)J. Santhakumar</p> <p>9)Dr.Ambica Prakash Mani</p> <p>10)Aradhna Saini</p> <p>11)Gaurav Dhuriya</p> <p>12)Nirdhum Narayan</p> <p>(72)Name of Inventor :</p> <p>1)Dr. Jitendranath Mungara</p> <p>2)Dr. Muthukumar S</p> <p>3)Dr. Manoj Sharma</p> <p>4)Dr. Pooja Singh</p> <p>5)Dr Nandhagopal S Munusamy</p> <p>6)Dr. Ram Shringar Raw</p> <p>7)Mr. Gaurav Tripathi</p> <p>8)J. Santhakumar</p> <p>9)Dr.Ambica Prakash Mani</p> <p>10)Aradhna Saini</p> <p>11)Gaurav Dhuriya</p> <p>12)Nirdhum Narayan</p>
--	--

(57) Abstract :

The present invention relates to advance face mask for covid-19 protection using artificial intelligence with integrated quality and proximity detection. The objective of the present invention is to solve the problems in the prior art technologies related to face mask design for protection of viral infection.

No. of Pages : 28 No. of Claims : 5

(12) PATENT APPLICATION PUBLICATION

(21) Application No.202141025016 A

(19) INDIA

(22) Date of filing of Application :04/06/2021

(43) Publication Date : 11/06/2021

(54) Title of the invention : AYURVEDIC HERBAL FORMULATION FOR INFERTILITY

(51) International classification	:A61K0036880000, A61K0036480000, A61K0009200000, A61K0036486000, A61K0036185000	(71)Name of Applicant : 1)Dr. VIJAYABHASKAR KANAKAM Address of Applicant :Associate Professor, St. Peters Institute of Pharmaceutical Science, Vidyanagar, Hanamkonda, Warangal urban, Telangana, Pincode: 506002 Telangana India 2)Ms. SREEPADA NAVYASRI 3)Mr. BANDI NIKHIL 4)Mr. BODIGE PAVANKALYAN 5)Mr. PINGALI SRINIVASA RAO 6)Mr. KANJARLA NARASIMHA
(31) Priority Document No	:NA	(72)Name of Inventor : 1)Dr. VIJAYABHASKAR KANAKAM 2)Ms. SREEPADA NAVYASRI 3)Mr. BANDI NIKHIL 4)Mr. BODIGE PAVANKALYAN 5)Mr. PINGALI SRINIVASA RAO 6)Mr. KANJARLA NARASIMHA
(32) Priority Date	:NA	
(33) Name of priority country	:NA	
(86) International Application No	:PCT//	
Filing Date	:01/01/1900	
(87) International Publication No	: NA	
(61) Patent of Addition to Application	:NA	
Number	:NA	
Filing Date	:NA	
(62) Divisional to Application Number	:NA	
Filing Date	:NA	

(57) Abstract :

The present invention relates to preparation of herbal tablets by using hydro alcoholic extract of different plant and seeds such as mucuna pruriens, leaf extract of Desmodium latifolium, shilajith, seed of Putranjiva Roxburghii, Curculigo orchids ryzome To this adding excipients. Tablets were compressed by using direct compression technique.

No. of Pages : 10 No. of Claims : 3

(12) PATENT APPLICATION PUBLICATION

(21) Application No.202141025017 A

(19) INDIA

(22) Date of filing of Application :04/06/2021

(43) Publication Date : 11/06/2021

(54) Title of the invention : HERBAL GEL FOR TREATMENT OF ACNE

(51) International classification	:A61K0036470000, A61Q0019000000, A61K0036580000, A61K0009000000, A61K0008970000	(71)Name of Applicant : 1)Dr. K. Kranthi Kumar Address of Applicant :HOD Department of Pharmaceutics, Mahathi College of Pharmacy, Angalu - CTM Rd, Madanapalle, Andhra Pradesh, Pincode: 517319 Andhra Pradesh India
(31) Priority Document No	:NA	2)Mr. Moturi Mahesh
(32) Priority Date	:NA	3)Mr. Shaik Naseeb Basha
(33) Name of priority country	:NA	4)Dr. Zakir Hussain Shaik Mohammad
(86) International Application No	:PCT//	(72)Name of Inventor :
Filing Date	:01/01/1900	1)Dr. K. Kranthi Kumar
(87) International Publication No	: NA	2)Mr. Moturi Mahesh
(61) Patent of Addition to Application	:NA	3)Mr. Shaik Naseeb Basha
Number	:NA	4)Dr. Zakir Hussain Shaik Mohammad
Filing Date	:NA	
(62) Divisional to Application Number	:NA	
Filing Date	:NA	

(57) Abstract :

The present invention relates to the preparation of herbal gel to treat acne using potent antimicrobial plants extracts such as aerial parts of *Acalypha indica* extract, leaves of *Azadirachta indica* extract, leaves and twigs of *Camellia sinensis* extract, *Thymus vulgaris* oil, *Thuja orientalis* oil. The skin irritation studies show that anti-acne gel formulations dose not produces any severe irritation, redness of skin.

No. of Pages : 14 No. of Claims : 3

(54) Title of the invention : Phyllanthus Niruri Extract Composition for Jaundice and Its Preparation Method Thereof

<p>(51) International classification :A61K0036470000, A61K0008970000, A61N0005060000, A23L0033190000, A61K0031198000</p> <p>(31) Priority Document No :NA</p> <p>(32) Priority Date :NA</p> <p>(33) Name of priority country :NA</p> <p>(86) International Application No :PCT// Filing Date :01/01/1900</p> <p>(87) International Publication No : NA</p> <p>(61) Patent of Addition to Application Number :NA Filing Date :NA</p> <p>(62) Divisional to Application Number :NA Filing Date :NA</p>	<p>(71)Name of Applicant :</p> <p>1)Dr.Aruna Kumari Nakkella Address of Applicant :Assistant Principal, Dr.BR Ambedkar University, Srikakulam, D.No:20-14-13, Ramachandra Rao Peta, Near SBI, Kambal Tank Branch, Rajamahendravaram, East Godavari-533103, Andhra Pradesh, India Andhra Pradesh India</p> <p>2)Dr.Nikhil Krishna Sairam Vannemreddy</p> <p>3)Dr.P.Sri Rama Murthy</p> <p>4)Dr.Surapaneni Krishna Mohan</p> <p>5)Dr.C.Ananda Vayaravel</p> <p>6)Sofia Khanam</p> <p>7)Dr.Pooja Choubey</p> <p>8)Dr.Kalai Selvi Rajendiran</p> <p>9)Dr.Santosh Karajgi</p> <p>10)Prof.K.Basavaiah</p> <p>11)Dr.Dharmasoth.Rama Devi</p> <p>12)Dr.M.Monisha</p> <p>13)Dr.M.Neela</p> <p>14)Dr.S.Srilalitha</p> <p>(72)Name of Inventor :</p> <p>1)Dr.Aruna Kumari Nakkella</p> <p>2)Dr.Nikhil Krishna Sairam Vannemreddy</p> <p>3)Dr.P.Sri Rama Murthy</p> <p>4)Dr.Surapaneni Krishna Mohan</p> <p>5)Dr.C.Ananda Vayaravel</p> <p>6)Sofia Khanam</p> <p>7)Dr.Pooja Choubey</p> <p>8)Dr.Kalai Selvi Rajendiran</p> <p>9)Dr.Santosh Karajgi</p> <p>10)Prof.K.Basavaiah</p> <p>11)Dr.Dharmasoth.Rama Devi</p> <p>12)Dr.M.Monisha</p> <p>13)Dr.M.Neela</p> <p>14)Dr.S.Srilalitha</p>
--	---

(57) Abstract :

ABSTRACT: Title: Phyllanthus Niruri Extract Composition for Jaundice and Its Preparation Method Thereof The present disclosure proposes Phyllanthus niruri extract composition for jaundice and its preparation method thereof. The proposed composition is provided in a powdered and edible form that is to be mixed with either milk or buttermilk for daily intake for jaundice. The Phyllanthus niruri extract decreases the bilirubin level and oxidative stress in phenylhydrazine-induced neonatal jaundice. The composition of Phyllanthus niruri reduces the use of synthetic drugs. The composition of Phyllanthus niruri is a cost-effective composition to cure jaundice with no harmful side effects for normal cells.

No. of Pages : 11 No. of Claims : 4

(12) PATENT APPLICATION PUBLICATION

(21) Application No.202141025043 A

(19) INDIA

(22) Date of filing of Application :05/06/2021

(43) Publication Date : 11/06/2021

(54) Title of the invention : Innocuous Mosquito Repellent and Method of Making the Same

(51) International classification	:A01M0029120000, A01N0065000000, A01M0013000000, A61Q0017020000, A01M0001200000	(71) Name of Applicant : 1)Jonna Jagadesh Kiran Kumar Address of Applicant :37-10-111/A/2, Nggo™s Colony, Murali Nagar, Near Masjid, Visakhapatnam-, 530007, Andhra Pradesh, India. Andhra Pradesh India
(31) Priority Document No	:NA	(72) Name of Inventor :
(32) Priority Date	:NA	1)Jonna Jagadesh Kiran Kumar
(33) Name of priority country	:NA	
(86) International Application No	:PCT//	
Filing Date	:01/01/1900	
(87) International Publication No	: NA	
(61) Patent of Addition to Application Number	:NA	
Filing Date	:NA	
(62) Divisional to Application Number	:NA	
Filing Date	:NA	

(57) Abstract :

ABSTRACT: Title: Innocuous Mosquito Repellent and Method of Making the Same The present disclosure proposes an innocuous mosquito repellent that comprises 250 ml of water and one to two drops of acetone. The innocuous mosquito repellent causes no harm to users when the user inhales the vapours of the mosquito repellent. The proposed mosquito repellent is of low cost and easily accessible for everyone. The proposed mosquito repellent is effective against mosquitoes and causes them to lose their wings. The proposed mosquito repellent makes the mosquitoes fall on the ground within minutes when kept in the vaporizer. The proposed mosquito repellent is a low-cost mosquito repellent with minimal ingredients.

No. of Pages : 10 No. of Claims : 4

(54) Title of the invention : Building Confidential and Efficient Query Services in the Cloud with RASP Data Perturbation

<p>(51) International classification</p> <p>(31) Priority Document No</p> <p>(32) Priority Date</p> <p>(33) Name of priority country</p> <p>(86) International Application No Filing Date</p> <p>(87) International Publication No</p> <p>(61) Patent of Addition to Application Number: Filing Date</p> <p>(62) Divisional to Application Number Filing Date</p>	<p>:G06F0016270000, H04L0029080000, A61B0017160000, G06F0016330000, G06F0016242000</p> <p>:NA</p> <p>:NA</p> <p>:NA</p> <p>:PCT// :01/01/1900</p> <p>: NA</p> <p>:NA</p> <p>:NA</p> <p>:NA</p>	<p>(71)Name of Applicant :</p> <p>1)A.Chandra Mouli, Associate Professor/ Department of CSE, Potti Sriramulu Chalavadi Mallikarjuna Rao College of Engineering and Technology Address of Applicant :Potti Sriramulu Chalavadi Mallikarjuna Rao College of Engineering and Technology. Kotahapeta,Vijayawada, A.P-520001. Andhra Pradesh India</p> <p>2)Er. Sandeep Ravikanti, Assistant Professor / Department of CSE, Methodist College of Engineering & Technology.</p> <p>3)Unnati Khanapurkar, Assistant Professor / Department of CSE, Methodist College of Engineering & Technology.</p> <p>4)B. Sowjanya, Assistant Professor / Department of CSE, Methodist College of Engineering & Technology.</p> <p>5)Khutaija Abid, Assistant Professor / Department of IT, Lords Institute of Engineering & Technology</p> <p>6)Kaneez Fatima, Assistant Professor / Department of IT, Lords Institute of Engineering & Technology</p> <p>(72)Name of Inventor :</p> <p>1)A.Chandra Mouli, Associate Professor/ Department of CSE, Potti Sriramulu Chalavadi Mallikarjuna Rao College of Engineering and Technology</p> <p>2)Er. Sandeep Ravikanti, Assistant Professor / Department of CSE, Methodist College of Engineering & Technology.</p> <p>3)Unnati Khanapurkar, Assistant Professor / Department of CSE, Methodist College of Engineering & Technology.</p> <p>4)B. Sowjanya, Assistant Professor / Department of CSE, Methodist College of Engineering & Technology.</p> <p>5)Khutaija Abid, Assistant Professor / Department of IT, Lords Institute of Engineering & Technology</p> <p>6)Kaneez Fatima, Assistant Professor / Department of IT, Lords Institute of Engineering & Technology</p>
---	--	--

(57) Abstract :

Abstract With the improvement of administrations figuring and distributed computing, it has turned out to be conceivable to outsource extensive databases to database specialist co-ops and let the suppliers keep up the range-inquiry benefit. Nonetheless, a few information may be touchy that the information proprietor does not have any desire to move to the cloud unless the information classification and inquiry security are ensured. We propose the Random Space Encryption (RASP) approach that permits productive range look with more grounded assault versatility than existing proficiency centered methodologies. The arbitrary space irritation (RASP) information annoyance technique to give secure and proficient range question and kNN inquiry administrations for ensured information in the cloud. The RASP information annoyance strategy consolidates arranging protecting encryption, dimensionality development, arbitrary com motion infusion, and irregular projection, to give solid flexibility to assaults on the irritated information and questions. It likewise saves multidimensional reaches, which enables existing ordering systems to be connected to speedup extend question handling. The kNN-R calculation is intended to work with the RASP go inquiry calculation to process the kNN inquiries.

No. of Pages : 15 No. of Claims : 5

(54) Title of the invention : SMART COMB WITH MASSAGING STROKES TO IMPROVE HAIR GROWTH

<p>(51) International classification</p> <p>(31) Priority Document No</p> <p>(32) Priority Date</p> <p>(33) Name of priority country</p> <p>(86) International Application No Filing Date</p> <p>(87) International Publication No</p> <p>(61) Patent of Addition to Application Number Filing Date</p> <p>(62) Divisional to Application Number Filing Date</p>	<p>:A61H0007000000, A61K0008920000, A61Q0005000000, A45D0024220000, A61Q0007000000</p> <p>:NA</p> <p>:NA</p> <p>:NA</p> <p>:PCT// :01/01/1900</p> <p>: NA</p> <p>:NA :NA</p> <p>:NA :NA</p>	<p>(71)Name of Applicant :</p> <p>1)Dr.R.SRIDEVI Address of Applicant :PROFESSOR, DEPT. OF COMPUTER SCIENCE AND ENGINEERING, K.RAMAKRISHNAN COLLEGE OF ENGINEERING, SAMAYAPURAM, TRICHY - PIN 621 112 Tamil Nadu India</p> <p>2)Dr. PRATHIBA. L</p> <p>3)Dr. VINAY KUMAR NASSA</p> <p>4)TEJAL JANARDAN MAHAJAN</p> <p>5)Dr.ISHA SUWALKA</p> <p>6)Dr. SHUBHAJIT HALDER</p> <p>7)ANUSHA LINDA KOSTKA J E</p> <p>8)Dr. ANUPAM JAIN</p> <p>9)Mr.MOHIT</p> <p>10)Dr. PRATIK GITE</p> <p>(72)Name of Inventor :</p> <p>1)Dr.R.SRIDEVI</p> <p>2)Dr. PRATHIBA. L</p> <p>3)Dr. VINAY KUMAR NASSA</p> <p>4)TEJAL JANARDAN MAHAJAN</p> <p>5)Dr.ISHA SUWALKA</p> <p>6)Dr. SHUBHAJIT HALDER</p> <p>7)ANUSHA LINDA KOSTKA J E</p> <p>8)Dr. ANUPAM JAIN</p> <p>9)Mr.MOHIT</p> <p>10)Dr. PRATIK GITE</p>
--	---	--

(57) Abstract :

Smart comb with massaging strokes to improve hair growth. Is used to estimate the rate of hair fall and increase the intensity of massaging along with various strokes of massaging accordingly to stock or reduce hair falls substantially. The proposed smart comb works on the technique of artificial intelligence. The smart comb comprises two components, one for filling up or hair oil or hair serum for the purpose of massage, and the second component is the artificial intelligence technique to recognize the volume and condition of the scalp. The smart comb is IOT enabled since it can be controlled using the smartphone or any electronic gadgets of the user.

No. of Pages : 22 No. of Claims : 4

(12) PATENT APPLICATION PUBLICATION

(21) Application No.202141025106 A

(19) INDIA

(22) Date of filing of Application :06/06/2021

(43) Publication Date : 11/06/2021

(54) Title of the invention : IN-LINE FUEL FILTER OUTER CASING DISSAMBLEY AND REMANUFACTURING

(51) International classification	:B01D0036000000, F02M0037220000, B01D0035300000, B01D0029960000, H04R0001020000	(71) Name of Applicant : 1)AZEEM HAFIZ P A Address of Applicant :Associate Professor, Department of Mechanical Engineering, Musaliar College of Engineering, Chirayinkeezhu, Thiruvananthapuram, Kerala 695304 Kerala India
(31) Priority Document No	:NA	2)AKASH R KRISHNAN
(32) Priority Date	:NA	3)SARFAZ MUHAMMED B
(33) Name of priority country	:NA	4)ARSHED A
(86) International Application No	:PCT//	5)ASWIN SUDHEER
Filing Date	:01/01/1900	6)MOHAMMED ASADULLAH THAKUR
(87) International Publication No	: NA	(72) Name of Inventor :
(61) Patent of Addition to Application Number	:NA	1)AZEEM HAFIZ P A
Filing Date	:NA	2)AKASH R KRISHNAN
(62) Divisional to Application Number	:NA	3)SARFAZ MUHAMMED B
Filing Date	:NA	4)ARSHED A
		5)ASWIN SUDHEER
		6)MOHAMMED ASADULLAH THAKUR

(57) Abstract :

IN-LINE FUEL FILTER OUTER CASING DISASSEMBLY AND REMANUFACTURING ABSTRACT Embodiments of the present disclosure are related to end-of-life vehicles for disassembly and remanufacturing of in-line fuel filter that includes a filter cap, bottom casing and a removable filter element. End-of-life vehicles (ELVs) directive targets to minimize the waste generated from vehicles when they are disposed, by reusing and recycling for sustainability, economic liability and adoption of eco-friendly technologies. Design for remanufacture plays an important role in enhancing the performance of product. Disassembly too, is vital for the separation of the reusable and non-reusable components. A non-reusable in-line fuel filter component is configured and remanufactured as a reusable component. The automobile component provides a have high reusability rate as it includes a threaded bottle cap design in the filter casing instead of fully enclosed casing. Thus, helps in advanced but simple maintenance policy by simply cleaning or replacing the inner filter element.

No. of Pages : 17 No. of Claims : 7

(12) PATENT APPLICATION PUBLICATION

(21) Application No.202141025111 A

(19) INDIA

(22) Date of filing of Application :06/06/2021

(43) Publication Date : 11/06/2021

(54) Title of the invention : A VEHICLE TIRE CONTROL SYSTEM AT CURVED ROADS USING INTELLIGENT INTERFACES AND SUPPORT VECTOR MACHINES

<p>(51) International classification</p> <p>(31) Priority Document No</p> <p>(32) Priority Date</p> <p>(33) Name of priority country</p> <p>(86) International Application No Filing Date</p> <p>(87) International Publication No</p> <p>(61) Patent of Addition to Application Number: Filing Date</p> <p>(62) Divisional to Application Number Filing Date</p>	<p>:B60T0008172000, B60C0023000000, G05B0019418000, G06N0003120000, G06K0009620000</p> <p>:NA</p> <p>:NA</p> <p>:NA</p> <p>:PCT// :01/01/1900</p> <p>: NA</p> <p>:NA</p> <p>:NA</p> <p>:NA</p>	<p>(71)Name of Applicant :</p> <p>1)Dr.V.Sujatha Address of Applicant :Associate Professor, Department of Computer Science and Engineering, Vignan Nirula Institute of Technology and Science for Womens, Pedapalalaluru, Guntur, Andhra Pradesh, India. Pin Code:522005 Andhra Pradesh India</p> <p>2)Dr.Raghavendra N</p> <p>3)Mr.C S Pavan Kumar</p> <p>4)Dr.Rabinarayan Satpathy</p> <p>5)Dr.Sushma Jaiswal</p> <p>6)Dr.S.Selvakanmani</p> <p>7)Mr.Soubraylu Sivakumar</p> <p>8)Mr.Chintala Venkatesh</p> <p>9)Dr.A.Geetha</p> <p>10)Mr.Tarun Jaiswal</p> <p>(72)Name of Inventor :</p> <p>1)Dr.V.Sujatha</p> <p>2)Dr.Raghavendra N</p> <p>3)Mr.C S Pavan Kumar</p> <p>4)Dr.Rabinarayan Satpathy</p> <p>5)Dr.Sushma Jaiswal</p> <p>6)Dr.S.Selvakanmani</p> <p>7)Mr.Soubraylu Sivakumar</p> <p>8)Mr.Chintala Venkatesh</p> <p>9)Dr.A.Geetha</p> <p>10)Mr.Tarun Jaiswal</p>
---	--	---

(57) Abstract :

ABSTRACT A VEHICLE TIRE CONTROL SYSTEM AT CURVED ROADS USING INTELLIGENT INTERFACES AND SUPPORT VECTOR MACHINES [034] The present invention discloses a vehicle tire control system at curved roads using intelligent interfaces and support vector machines. The method and system includes, but not limited to, a plurality of sensors to sense the road vicinity and irregular bands of the driving path; a processing unit to receive its input from the sensors and guide the steering mechanism to control the tire direction of the vehicle; a support vector machine implemented to calculate the predefined functions for helping the processing unit in guiding the steering mechanism; and an interactive database unit for acquiring and storing, road curve sensed data with respect to the acceleration of one specified point of the tire.

No. of Pages : 23 No. of Claims : 9

(12) PATENT APPLICATION PUBLICATION

(21) Application No.202141025148 A

(19) INDIA

(22) Date of filing of Application :07/06/2021

(43) Publication Date : 11/06/2021

(54) Title of the invention : IOT BASED SMART LIGHTING SYSTEM FOR FIVE DIFFERENT STUDIO TYPED SMART HOUSES

(51) International classification	:H04L0029080000, G06Q0050160000, H05B0047190000, G06Q0050060000, E06B0009020000	(71)Name of Applicant : 1)Dr. M. NAGABUSHANAM Address of Applicant :ASSISTANT PROFESSOR DEPARTMENT OF ELECTRONICS & COMMUNICATION ENGINEERING M.S. RAMAIAH INSTITUTE OF TECHNOLOGY MSRIT POST, M S RAMAIAH NAGAR, MATHIKERE, BENGALURU, KARNATAKA 560054 Karnataka India 2)Mrs. ARUDRA ANNEPU 3)Dr. KUMARASWAMY S 4)Dr. DEVANANDA S N 5)Mrs. SWATHI PAI M 6)Dr. SARAVANAKUMAR GURUSAMY 7)Mr.NAVEENA PAI G 8)Mr.KAPIL KUSHWAHA
(31) Priority Document No	:NA	(72)Name of Inventor : 1)Dr. M. NAGABUSHANAM 2)Mrs. ARUDRA ANNEPU 3)Dr. KUMARASWAMY S 4)Dr. DEVANANDA S N 5)Mrs. SWATHI PAI M 6)Dr. SARAVANAKUMAR GURUSAMY 7)Mr.NAVEENA PAI G 8)Mr.KAPIL KUSHWAHA
(32) Priority Date	:NA	
(33) Name of priority country	:NA	
(86) International Application No	:PCT//	
Filing Date	:01/01/1900	
(87) International Publication No	: NA	
(61) Patent of Addition to Application	:NA	
Number	:NA	
Filing Date	:NA	
(62) Divisional to Application Number	:NA	
Filing Date	:NA	

(57) Abstract :

ABSTRACT IOT BASED SMART LIGHTING SYSTEM FOR FIVE DIFFERENT STUDIO TYPED SMART HOUSES There is an up-surging attention in the development of Internet of Things (IoT) aided smart houses and commercial buildings from the past years. Despite, the expansion of these smart buildings is obstructed by the proclaimed cost in installation and production also it have struggle in evaluating under large-scale in the field. This present invention, is therefore designed and organization of an emergency smart light- IoT based implementation in the smart houses and commercial complexes. The vital benefit of this smart light structure is that it is assembled on the top of the prevailing amenities present in the houses and commercial buildings. As a novel attempt, we projected and organized our developed IoT system in five different smart houses with multi-layered complexes. Exhausting the real framed data from different types of buildings, we in the present invention proposed a novel system which can deliver >95% packet delivery rate in average. Moreover, the evaluation assays also delivered toughness and constant stability system to diverse environmental fluxes. Thus the present invention delivers a practical visions to enable the application of IoT based smart houses and commercial building development.

No. of Pages : 17 No. of Claims : 9

(12) PATENT APPLICATION PUBLICATION

(21) Application No.202141025216 A

(19) INDIA

(22) Date of filing of Application :07/06/2021

(43) Publication Date : 11/06/2021

(54) Title of the invention : NOVEL POLYTETRAMERS AND AQUEOUS DISPERSIONS CONTAINING THEM

(51) International classification	:A01N0025300000, C08G0018120000, D06P0001000000, C09D0005020000, C08G0018080000	(71) Name of Applicant : 1)SAHAANA HYDRO BIOTECH & ORGANIC PVT. LTD., Address of Applicant :Plot No.6, BSR Akruthi Greenwood Layout, Konasandra, Jigani, Bangalore, India, 560105 Karnataka India
(31) Priority Document No	:NA	(72) Name of Inventor :
(32) Priority Date	:NA	1)Rajkumar Ganugula
(33) Name of priority country	:NA	2)Shruthi M Shenava
(86) International Application No	:PCT//	3)J V Shanmukha Kumar
Filing Date	:01/01/1900	
(87) International Publication No	: NA	
(61) Patent of Addition to Application Number	:NA	
Filing Date	:NA	
(62) Divisional to Application Number	:NA	
Filing Date	:NA	

(57) Abstract :

The invention relates to compositions of novel polytetramers and their use in dispersing active ingredients such as fluorescent dyes for coating applications such as colouring of textile fabrics. The invention also discloses the synthesis of the polytetramers and preparation of aqueous dispersions of active ingredients containing the polytetramers.

No. of Pages : 26 No. of Claims : 6

(12) PATENT APPLICATION PUBLICATION

(21) Application No.202141025244 A

(19) INDIA

(22) Date of filing of Application :07/06/2021

(43) Publication Date : 11/06/2021

(54) Title of the invention : FULL SPECTRUM TURMERIC EXTRACT BY FERMENTATION PROCESS

(51) International classification	:A61K0036906600, A23L0033105000, A61K0031120000, A23L0005200000, A23L0005000000	(71) Name of Applicant : 1)Jinu John Address of Applicant :Assistant Professor Department of Biotechnology CMS College Kottayam Kerala Kerala India
(31) Priority Document No	:NA	(72) Name of Inventor :
(32) Priority Date	:NA	1)Jinu John
(33) Name of priority country	:NA	
(86) International Application No	:PCT// /	
Filing Date	:01/01/1900	
(87) International Publication No	: NA	
(61) Patent of Addition to Application Number	:NA	
Filing Date	:NA	
(62) Divisional to Application Number	:NA	
Filing Date	:NA	

(57) Abstract :

This invention discloses an economical and eco-friendly method for the manufacturing of full spectrum turmeric extract by fermentation process from fresh rhizome. Full spectrum turmeric extract contains most of the phytochemicals present in the natural plant and have better bioactivity by synergistic effect of curcuminoids and other phytonutrients. The present innovation can improve the taste, odor, solubility and bioavailability of phytochemicals in the extract, which enhances its therapeutic potential. This method further comprises blending of the turmeric essential oil with the final extract powder, thereby modulation of organoleptic properties for various applications such as dietary supplement, cosmetic and related industries. It provides a full spectrum turmeric extract with better bioactivity and free from toxic organic solvents.

No. of Pages : 11 No. of Claims : 5

(12) PATENT APPLICATION PUBLICATION

(21) Application No.202141025316 A

(19) INDIA

(22) Date of filing of Application :07/06/2021

(43) Publication Date : 11/06/2021

(54) Title of the invention : FIBER TO SUGAR FREE JELLY FROM BY-PRODUCT OF BEETROOT

(51) International classification	:A23L0021100000, A01C0021000000, A23L0021250000, H01M0010420000, A61K0031167000	(71) Name of Applicant : 1)B VISHNUPRIYA Address of Applicant :B VISHNUPRIYA, Assistant Professor,PG and Reasearch Department of Biotechnology,Kongunadu Arts and Science College, Coimbatore, Tamilnadu. Tamil Nadu India
(31) Priority Document No	:NA	2)V.AGALYA
(32) Priority Date	:NA	(72) Name of Inventor :
(33) Name of priority country	:NA	1)B VISHNUPRIYA
(86) International Application No	:PCT//	2)V.AGALYA
Filing Date	:01/01/1900	
(87) International Publication No	: NA	
(61) Patent of Addition to Application Number	:NA	
Filing Date	:NA	
(62) Divisional to Application Number	:NA	
Filing Date	:NA	

(57) Abstract :

A Fiber to sugar free jelly consists of a 20g of beetroot peel powder from 400g beetroot; and 50ml of distilled water. The jelly is consisting of a set of ingredients.The ingredients are agar-agar(1g),Honey (required amount),beetroot peel extract (5ml to 5ml), palm Jaggery (4-5g) ,water 30ml to 40ml,castor oil(1/2 tea spoon.

No. of Pages : 21 No. of Claims : 6

(12) PATENT APPLICATION PUBLICATION

(21) Application No.202143022279 A

(19) INDIA

(22) Date of filing of Application :18/05/2021

(43) Publication Date : 11/06/2021

(54) Title of the invention : FUEL TANK CAP ASSEMBLY

(51) International classification	:B60K0015040000, F02M0037000000, B60K0015050000, B60K0015030000, H01R0013627000	(71) Name of Applicant : 1)Sandhar Automotives Bommasandra Address of Applicant :Plot No.8, Bommasandra- Jigani link Road KIADB Industrial Area, Taluk- Anekal, Bengaluru, Karnataka 562106 Karnataka India
(31) Priority Document No	:NA	(72) Name of Inventor :
(32) Priority Date	:NA	1)SETH, Akshansh
(33) Name of priority country	:NA	2)DESWAL, Pardeep
(86) International Application No	:NA	3)NAIK, Dillip Kumar
Filing Date	:NA	
(87) International Publication No	: NA	
(61) Patent of Addition to Application Number	:	
Filed on	:01/01/1900	
(62) Divisional to Application Number	:NA	
Filing Date	:NA	

(57) Abstract :

ABSTRACT TITLE OF THE INVENTION: FUEL TANK CAP ASSEMBLY A fuel tank cap assembly (200) is disclosed. The assembly (200) includes a cap unit (207), a main body (205) coupled to the cap unit (207) and a latch assembly (227) coupled to the main body (205) and the cap unit (207) via a pin (205d). The latch assembly (227) including a latch lever (227a) and a resilient means (227c). The latch lever (227a) including a first end (b1) and a second end (b2). The latch lever (227a) is operatively coupled to a latch cable for opening/closing the cap unit (207). The latch cable is coupled to the second end (b2) while the resilient means (227c) and the pin (205d) are coupled to the first end (b1) of the latch lever (227a). The pin (205d) /the resilient means (227c) is disposed at a pre-defined distance from an axis along which the latch cable is pulled. The pre-defined distance produces a leverage thereby reducing force for operating the fuel tank cap assembly (200). FIG. 6a

No. of Pages : 33 No. of Claims : 9

(12) PATENT APPLICATION PUBLICATION

(21) Application No.202147023785 A

(19) INDIA

(22) Date of filing of Application :28/05/2021

(43) Publication Date : 11/06/2021

(54) Title of the invention : A GROWTH MEDIA COMPOSITION AND IMPROVED METHODS OF PRODUCING BIOMASS AND VALUE ADDED PRODUCT

(51) International classification	:C12N0001120000, C12P0007060000, C12P0007640000, G06F0016280000, C12N0001200000	(71) Name of Applicant : 1)STRING BIO PRIVATE LIMITED Address of Applicant :Bangalore Bioinnovation Centre, Biotech Park, Electronics City Phase 1 Bangalore, Karnataka 560100 Karnataka India
(31) Priority Document No	:201841042227	(72) Name of Inventor :
(32) Priority Date	:09/11/2018	1)PALABHANVI, Basavaraj
(33) Name of priority country	:India	2)C, Sandeep Kumar
(86) International Application No	:PCT/IB2019/059664	3)SUBRAMANIAN, Hamsini
Filing Date	:11/11/2019	4)S, Naga Sairam
(87) International Publication No	:WO 2020/095281	5)SHINGALA, Purvesh
(61) Patent of Addition to Application Number	:NA	6)SUBBIAN, Ezhil
Filing Date	:NA	
(62) Divisional to Application Number	:NA	
Filing Date	:NA	

(57) Abstract :

The present disclosure relates to growth media composition. The disclosure further relates to a method of producing the biomass at higher concentration by employing a growth media composition. The disclosure further relates to a method of producing value added product employing growth media composition. The growth media composition of the present disclosure is homogenous in nature and is self-sterilized. The present disclosure provides for enhanced productivity of the biomass and the value added products, respectively employing gaseous substrate.

No. of Pages : 33 No. of Claims : 26

(12) PATENT APPLICATION PUBLICATION

(21) Application No.202031023859 A

(19) INDIA

(22) Date of filing of Application :07/06/2020

(43) Publication Date : 11/06/2021

(54) Title of the invention : BACTERIAL AND VIRAL INFECTION LOCALIZATION AND CLASSIFICATION USING X-RAY AND CT IMAGES

(51) International classification	:A61B0006000000, G01N0033569000, H04L0012741000, C12Q0001689000, C07K0014220000	(71) Name of Applicant : 1)Arvind Choubey Address of Applicant :Director IIIT Bhagalpur BCE Campus Sabour, Bhagalpur Bihar India 2)Sandeep Raj
(31) Priority Document No	:NA	(72) Name of Inventor :
(32) Priority Date	:NA	1)Sandeep Raj
(33) Name of priority country	:NA	2)Arvind Choubey
(86) International Application No	:NA	
Filing Date	:NA	
(87) International Publication No	: NA	
(61) Patent of Addition to Application Number	:NA	
Filing Date	:NA	
(62) Divisional to Application Number	:NA	
Filing Date	:NA	

(57) Abstract :

This invention relates to a method and a decision support system capable of localizing and classifying the bacterial & viral infections using chest X-rays/CT scan systems. The proposed method pre-processes the input images to highlight the findings, rescale the images and gamma correction. The pre-processed input chest X-ray/CT scan images are used to extract the lungs. The extracted lungs alongwith the radiological findings are used to train the software to classify into normal and abnormal categories using machine learning/deep learning mechanism. The information gathered is transferred through the transfer learning approach for classification of chest abnormalities into bacterial and viral infections. The output is generated in form of report (both in .pdf copy and messages of mobile phones) and can be used for screening targeted for mass.

No. of Pages : 14 No. of Claims : 9

(54) Title of the invention : ARTIFICIAL INTELLIGENCE BASED OUTDOOR NAVIGATION SYSTEM USING AUGMENTED REALITY

<p>(51) International classification</p> <p>(31) Priority Document No</p> <p>(32) Priority Date</p> <p>(33) Name of priority country</p> <p>(86) International Application No Filing Date</p> <p>(87) International Publication No</p> <p>(61) Patent of Addition to Application Number Filing Date</p> <p>(62) Divisional to Application Number Filing Date</p>	<p>:G01C0021340000, G06T0019000000, G06F0016290000, D01H0007600000, G01C0021200000</p> <p>:NA</p> <p>:NA</p> <p>:NA</p> <p>:NA</p> <p>:NA</p> <p>:NA</p> <p>:NA</p> <p>:NA</p> <p>:NA</p> <p>:NA</p>	<p>(71)Name of Applicant :</p> <p>1)Pratyusa Mukherjee Address of Applicant :School of Computer Engineering, Kalinga Institute of Industrial Technology (KIIT), Deemed to be University, Bhubaneshwar, Odisha, India. Pin - 751024 Orissa India</p> <p>2)Ms. Neha Kapila 3)Mr. Dhiraj Kapila 4)Dr. Ashulekha Gupta 5)Dr.Purnendu Shekhar Pandey 6)Dr. Hardeep Singh Saini 7)Dr. Sudip Mandal 8)Mr. Pijush Dutta 9)Dr. Chittaranjan Pradhan 10)Abhishek Bhattacharya 11)C.R.Srinivasan 12)Dr.S.Balamurugan</p> <p>(72)Name of Inventor :</p> <p>1)Pratyusa Mukherjee 2)Ms. Neha Kapila 3)Mr. Dhiraj Kapila 4)Dr. Ashulekha Gupta 5)Dr.Purnendu Shekhar Pandey 6)Dr. Hardeep Singh Saini 7)Dr. Sudip Mandal 8)Mr. Pijush Dutta 9)Dr. Chittaranjan Pradhan 10)Abhishek Bhattacharya 11)C.R.Srinivasan 12)Dr.S.Balamurugan</p>
--	--	--

(57) Abstract :

The Artificial Intelligence based Outdoor Navigation System using Augmented Reality (AIONS) helps the traveler(s) to make use of the AIONS to navigate the unknown places easily without deviating to wrong path using 3D map. The traveller(s) can take a photo about an object/scenery, etc. If the traveler(s) donTMt know how to reach that target location of the taken photo then they can send that taken photo to the cloud server. The cloud server will process the data of photo based on past history or previous database and it will generate a 3D map from the source person to the target. That 3D map will be send by cloud server to the source person. Then the traveller(s) can use that 3D map to navigate that target location easily and on time. The intelligent AIONS control unit helps the traveler(s) to navigate the unknown places and support the successful functioning of the whole AIONS system. By using this AIONS, the traveler(s) to make use of the AIONS to navigate the unknown places easily without deviating to wrong path using 3D map.

No. of Pages : 16 No. of Claims : 3

(12) PATENT APPLICATION PUBLICATION

(21) Application No.202131020491 A

(19) INDIA

(22) Date of filing of Application :05/05/2021

(43) Publication Date : 11/06/2021

(54) Title of the invention : SYSTEM FOR DEPRESSION DETECTION USING TEXTUAL AND EMOJI ANALYSIS IN SOCIAL-MEDIA THROUGH MACHINE LEARNING

<p>(51) International classification</p> <p>(31) Priority Document No</p> <p>(32) Priority Date</p> <p>(33) Name of priority country</p> <p>(86) International Application No Filing Date</p> <p>(87) International Publication No</p> <p>(61) Patent of Addition to Application Number Filing Date</p> <p>(62) Divisional to Application Number Filing Date</p>	<p>:G06Q0050000000, G06N0020000000, G06N0003080000, G06K0009000000, G06K0009460000</p> <p>:NA</p> <p>:NA</p> <p>:NA</p> <p>:NA</p> <p>:NA</p> <p>:NA</p> <p>:NA</p> <p>:NA</p> <p>:NA</p> <p>:NA</p>	<p>(71)Name of Applicant :</p> <p>1)Kumar Devadutta Address of Applicant :Assistant Professor, School of Computer Engineering, KIIT Deemed to be University, Bhubaneswar, Odisha , India Orissa India</p> <p>2)Navaneetha Krishnan Rajagopal</p> <p>3)Muhammed Yousoof Ismail</p> <p>4)Dr. Padmavati Shrivastava</p> <p>5)Dr. Ashwini Kumar</p> <p>6)Dr. Rajesh Deb Barman</p> <p>7)Dr.Vineet Dahiya</p> <p>8)Dr. Manish Gupta</p> <p>9)Ms.Charu Singh</p> <p>10)Dr. Niraj Upadhayaya</p> <p>(72)Name of Inventor :</p> <p>1)Kumar Devadutta</p> <p>2)Navaneetha Krishnan Rajagopal</p> <p>3)Muhammed Yousoof Ismail</p> <p>4)Dr. Padmavati Shrivastava</p> <p>5)Dr. Ashwini Kumar</p> <p>6)Dr. Rajesh Deb Barman</p> <p>7)Dr.Vineet Dahiya</p> <p>8)Dr. Manish Gupta</p> <p>9)Ms.Charu Singh</p> <p>10)Dr. Niraj Upadhayaya</p>
--	--	--

(57) Abstract :

The present invention relates to system for depression detection using textual and emoji analysis in social-media through machine learning. The objective of the present invention is to solve the problems in the prior art technologies related to social media userTMs depression detection using machine learning and data processing.

No. of Pages : 27 No. of Claims : 5

(54) Title of the invention : COMPOSITE SEPARATOR FOR LINGUAL RETAINERS

<p>(51) International classification</p> <p>(31) Priority Document No</p> <p>(32) Priority Date</p> <p>(33) Name of priority country</p> <p>(86) International Application No Filing Date</p> <p>(87) International Publication No</p> <p>(61) Patent of Addition to Application Number Filing Date</p> <p>(62) Divisional to Application Number Filing Date</p>	<p>:B32B0037000000, A61M0031000000, A61F0005560000, A61C0003000000, A61C0005000000</p> <p>:NA</p> <p>:NA</p> <p>:NA</p> <p>:NA</p> <p>:NA</p> <p>:NA</p> <p>:NA</p> <p>:NA</p> <p>:NA</p> <p>:NA</p>	<p>(71)Name of Applicant :</p> <p>1)Dr. Nivedita Sahoo Address of Applicant :Department of Orthodontics and Dentofacial Orthopedics, Kalinga Institute of Dental Sciences, KIIT Deemed to be University, Bhubaneswar, Odisha, Pin- 751024 Orissa India</p> <p>2)Dr. Aravind Krishnan R 3)Dr. Bhagabati Prasad Dash 4)Dr. M.S. Rami Reddy 5)Dr. Saranya S 6)Dr. K Nagarjuna Prasad 7)Dr. Bhumika Maikhuri 8)Dr. Rajat Mohanty 9)Dr. Jugajyoti Pathi</p> <p>(72)Name of Inventor :</p> <p>1)Dr. Nivedita Sahoo 2)Dr. Aravind Krishnan R 3)Dr. Bhagabati Prasad Dash 4)Dr. M.S. Rami Reddy 5)Dr. Saranya S 6)Dr. K Nagarjuna Prasad 7)Dr. Bhumika Maikhuri 8)Dr. Rajat Mohanty 9)Dr. Jugajyoti Pathi</p>
--	--	---

(57) Abstract :

A major difficulty faced by upcoming dental graduates is in stabilising the lingual wire. Inaccurate composite placement is also one of the chief concerns faced. It can lead to complications like lack of retention, poor oral hygiene as well as patient discomfort. Lingual retainers bonded on all six mandibular anterior teeth might induce unexpected movement of anterior teeth to such an extent that retreatment is necessary. Struggling to place the composite in the correct position in order to stabilize the fixed retainer is a major concern among beginners. When these complications are detected early, interceptive measures can be made which prevents damage to periodontal tissues and bone. However if they are found too late, they can be detrimental and retreatment might become necessary. The current method not only provides increased stability to the retainer wire but also allows placing the composite in a much easier and cost effective way.

No. of Pages : 11 No. of Claims : 10

(12) PATENT APPLICATION PUBLICATION

(21) Application No.202131020771 A

(19) INDIA

(22) Date of filing of Application :07/05/2021

(43) Publication Date : 11/06/2021

(54) Title of the invention : POWER GENERATION SYSTEMS USING ANIMAL POWER

(51) International classification	:F16H0001460000, F16H0003720000, F16H0001280000, B60K0007000000, F03D0015100000	(71) Name of Applicant : 1)AMIT KUMAR BAYEN Address of Applicant :P.O. Dakshin Bijoyanagar,via- Nimpith Ashram, P.S.- Joynagar, Dist.- South 24 Parganas, West Bengal, India - 743338 West Bengal India
(31) Priority Document No	:NA	2)ANKITA PAN
(32) Priority Date	:NA	(72) Name of Inventor :
(33) Name of priority country	:NA	1)AMIT KUMAR BAYEN
(86) International Application No	:NA	
Filing Date	:NA	
(87) International Publication No	: NA	
(61) Patent of Addition to Application Number:	:NA	
Filing Date	:NA	
(62) Divisional to Application Number	:NA	
Filing Date	:NA	

(57) Abstract :

The present invention provides power generation systems using animal power. The power generation system comprises multiple power generation units (100) comprising a first gear system (200), a second gear system (300), a third gear system (400), a plurality of animal cabins (101), levers (102) connecting the gear systems to the animal cabins and metal rail tops (103) for resting the levers, wherein the first gear system (200), the second gear system (300) and the third gear system (400) are configured in a planetary gear arrangement system. The system has the ability to use animal power efficiently for cost-effective generation of electricity. .

No. of Pages : 23 No. of Claims : 10

(54) Title of the invention : HYGIENIC BITE BOARD

<p>(51) International classification</p> <p>(31) Priority Document No</p> <p>(32) Priority Date</p> <p>(33) Name of priority country</p> <p>(86) International Application No Filing Date</p> <p>(87) International Publication No</p> <p>(61) Patent of Addition to Application Number Filing Date</p> <p>(62) Divisional to Application Number Filing Date</p>	<p>:A61C0007360000, A61M0016040000, A61C0007280000, A61C0013097000, A63B0071080000</p> <p>:NA</p> <p>:NA</p> <p>:NA</p> <p>:NA</p> <p>:NA</p> <p>: NA</p> <p>:NA</p> <p>:NA</p> <p>:NA</p> <p>:NA</p> <p>:NA</p>	<p>(71)Name of Applicant :</p> <p>1)Dr. Nivedita Sahoo Address of Applicant :Department of Orthodontics and Dentofacial Orthopedics, Kalinga Institute of Dental Sciences, KIIT Deemed to be University, Bhubaneswar, Odisha, Pin- 751024 Orissa India</p> <p>2)Dr. K Nagarjuna Prasad 3)Dr. Aravind Krishnan 4)Dr. Shristi Srivastava 5)Dr. Bhumika Maikhuri 6)Dr. Rajat Mohanty 7)Dr. Arpita Singh 8)Dr K. Krishna Murthy</p> <p>(72)Name of Inventor :</p> <p>1)Dr. Nivedita Sahoo 2)Dr. K Nagarjuna Prasad 3)Dr. Aravind Krishnan 4)Dr. Shristi Srivastava 5)Dr. Bhumika Maikhuri 6)Dr. Rajat Mohanty 7)Dr. Arpita Singh 8)Dr K. Krishna Murthy</p>
--	--	---

(57) Abstract :

Hygienic bite board consists of a rectangular ligature meshed occlusal table with soldered stainless steel sleeves (buccal and lingual). Through the sleeves the locking components (buccal and lingual) are passed which hooks onto the molar band buccally onto a buccal wire that is welded above the molar tube and lingually locks into the lingual sheath. The table acts as a lid that can be opened and closed by unlocking the buccal locking component only. Intraorally after placing the molar band with the appliance locked in position and separating medium applied onto the occlusal surface, bite block material is flowed onto the table with mesh and can be adjusted after it sets. The patient is trained to unlock and lock the buccal locking component. The appliance is removed once the purpose of the bite block is served and wouldn't require any cleaning of the occlusal surface.

No. of Pages : 13 No. of Claims : 10

(54) Title of the invention : STOP APPLIANCE - SIMULTANEOUSLY TREATING ORTHODONTIC PROBLEMS

<p>(51) International classification</p> <p>(31) Priority Document No</p> <p>(32) Priority Date</p> <p>(33) Name of priority country</p> <p>(86) International Application No Filing Date</p> <p>(87) International Publication No</p> <p>(61) Patent of Addition to Application Number Filing Date</p> <p>(62) Divisional to Application Number Filing Date</p>	<p>:A61C0007080000, A61C0007000000, A61F0005500000, A61F0005560000, A61P0017020000</p> <p>:NA</p> <p>:NA</p> <p>:NA</p> <p>:NA</p> <p>:NA</p> <p>: NA</p> <p>:NA</p> <p>:NA</p> <p>:NA</p> <p>:NA</p>	<p>(71)Name of Applicant :</p> <p>1)Dr. Aravind Krishnan Address of Applicant :Department of Orthodontics and Dentofacial Orthopedics, Kalinga Institute of Dental Sciences, KIIT Deemed to be University, Bhubaneswar, Odisha, Pin- 751024 Orissa India</p> <p>2)Dr. Nivedita Sahoo 3)Dr. K. Nagarjuna Prasad 4)Dr. Kanika Singh Dhull 5)Dr. Jugajyoti Pathi 6)Dr. Rajat Mohanty 7)Dr. Bhumika Maikhuri</p> <p>(72)Name of Inventor :</p> <p>1)Dr. Aravind Krishnan 2)Dr. K. Nagarjuna Prasad 3)Dr. Jugajyoti Pathi 4)Dr. Kanika Singh Dhull 5)Dr. Rajat Mohanty 6)Dr. Bhumika Maikhuri 7)Dr. Nivedita Sahoo</p>
--	---	---

(57) Abstract :

Oral equilibrium is affected by oral habits. If the oral habits persist beyond a certain age, it can cause great harm to the dentition. Therefore, it is important to intercept the habit and promote normal development. So, an appliance has been constructed which aims at treating a combination of problems simultaneously. The wire components include tongue crib and adams clasps on molars. Inclined plane with incisal capping is given in maxillary arch. It corrects habits such as tongue thrusting, thumb sucking, nail or lip biting, prevents cross bite, deep bite, flaring of maxillary anterior teeth and supra eruption of incisors. Also promotes mandibular growth by freeing it from distal interlocking. It is ideally indicated in early mixed dentition period with the intention of intercepting the habit and by promoting growth of mandible, before any established growth modification procedures are undertaken. This eventually leads to shortening of fixed orthodontic treatment time.

No. of Pages : 13 No. of Claims : 7

(12) PATENT APPLICATION PUBLICATION

(21) Application No.202131020960 A

(19) INDIA

(22) Date of filing of Application :08/05/2021

(43) Publication Date : 11/06/2021

(54) Title of the invention : A SYSTEM TO DETECT PREMATURE VENTRICULAR CONTRACTION (PVC) USING A MACHINE LEARNING ALGORITHM

(51) International classification	:A61B0005000000, A61B0005046800, A61B0005040000, G06K0009620000, G16H0050200000	(71) Name of Applicant : 1)Dr. Jagdeep Rahul Address of Applicant :Department of Electronics and Communication Engineering, Rajiv Gandhi University, Doimukh, Arunachal Pradesh, India-791112. Arunachal Pradesh India
(31) Priority Document No	:NA	2)Dr. Marpe Sora
(32) Priority Date	:NA	(72) Name of Inventor :
(33) Name of priority country	:NA	1)Dr. Jagdeep Rahul
(86) International Application No	:NA	2)Dr. Marpe Sora
Filing Date	:NA	
(87) International Publication No	: NA	
(61) Patent of Addition to Application Number	:NA	
Filing Date	:NA	
(62) Divisional to Application Number	:NA	
Filing Date	:NA	

(57) Abstract :

The present disclosure relates to a system and method in the field of medical science. More specifically, the invention is directed to a system that detects an automatic premature ventricular contraction (PVC) using a machine learning algorithm. The PVC beat classification is proposed for detecting ventricular arrhythmia. ECG arrhythmia records are considered from MIT-BIH AD and denoised by using the discrete wavelet transform (DWT). Thereafter, a two-stage median filter is used to eliminate the baseline wander to obtain the clean and smooth ECG signal. The proposed method calculates the statistical features of extracted QRS complex segment of both PVCs and normal beats. KNN and SVM algorithms are used for the performance evaluation of the proposed method. The results obtained have shown that the PVCs classification method is highly accurate and reliable, and can be used for automatic classification of arrhythmia.

No. of Pages : 30 No. of Claims : 10

(54) Title of the invention : AN AI AND IOT BASED TRAFFIC SURVEILLANCE SYSTEM FOR BIKE RIDERS AND METHOD THEREOF

<p>(51) International classification</p> <p>(31) Priority Document No</p> <p>(32) Priority Date</p> <p>(33) Name of priority country</p> <p>(86) International Application No Filing Date</p> <p>(87) International Publication No</p> <p>(61) Patent of Addition to Application Number Filing Date</p> <p>(62) Divisional to Application Number Filing Date</p>	<p>:H04N0007180000, G06K0009000000, G08G0001017000, G06Q0050260000, G08B0013196000</p> <p>:NA</p> <p>:NA</p> <p>:NA</p> <p>:NA</p> <p>:NA</p> <p>: NA</p> <p>:NA</p> <p>:NA</p> <p>:NA</p> <p>:NA</p>	<p>(71)Name of Applicant :</p> <p>1)Mrs Madhusmita Dash Address of Applicant :PhD Scholar, NIT Arunachal Pradesh, PapumPare, Arunachal Pradesh, India- 791112 Arunachal Pradesh India</p> <p>2)Aswini Kumar Patra</p> <p>3)Dr. V. Gokula Krishnan</p> <p>4)Yadav Rahul Shivaji</p> <p>5)Dr.PinagadiVenkateswara Rao</p> <p>6)Dr Vijay Kumar Sharma</p> <p>7)Mr. AmitavaChakraborty</p> <p>8)Priyanku Sharma</p> <p>9)B Yugandhar</p> <p>10)Dr. C. R. Rene Robin</p> <p>(72)Name of Inventor :</p> <p>1)Mrs Madhusmita Dash</p> <p>2)Aswini Kumar Patra</p> <p>3)Dr. V. Gokula Krishnan</p> <p>4)Yadav Rahul Shivaji</p> <p>5)Dr.PinagadiVenkateswara Rao</p> <p>6)Dr Vijay Kumar Sharma</p> <p>7)Mr. AmitavaChakraborty</p> <p>8)Priyanku Sharma</p> <p>9)B Yugandhar</p> <p>10)Dr. C. R. Rene Robin</p>
--	---	--

(57) Abstract :

The present disclosure relates to an A.I. and IoT based traffic surveillance system (100) for bike riders and the method (200) thereof. This invention is an A.I. and IoT based traffic surveillance system (100), comprising of a plurality of camera (102), a server (104) and a computing device (106). The cameras (102) are installed to capture images and videos of passerby and bike riders. The server (104) that receives these images is capable of processing and analyzing them to find the bike riders without helmet. Then the server sends the information regarding the violator to the computing device (106). The computing device (106) is any electronic device on which the law enforcement agencies can get the information about the violator. The present invention also discloses the method (200) thereof. (Fig. 1 will be the reference figures)

No. of Pages : 20 No. of Claims : 6

(12) PATENT APPLICATION PUBLICATION

(21) Application No.202131021838 A

(19) INDIA

(22) Date of filing of Application :14/05/2021

(43) Publication Date : 11/06/2021

(54) Title of the invention : PROCESS FOR LARGE SCALE ON-SITE PRODUCTION OF MICROBES FOR OIL & GAS FIELDS

(51) International classification	:C02F0103100000, C12M0001420000, C02F0101100000, E21B0043000000, E02B0017020000	(71) Name of Applicant : 1)Caliche Pvt. Ltd. Address of Applicant :10 Sweet Cottage, Near MLP Dog Squad Quarters, Golf Links, Shillong-793001, Meghalaya, India Meghalaya India
(31) Priority Document No	:NA	(72) Name of Inventor :
(32) Priority Date	:NA	1)Amit Priyadarshan
(33) Name of priority country	:NA	2)Anandh Mathew
(86) International Application No	:NA	3)Dr. Debajit Kalita
Filing Date	:NA	4)Prof S.R. Joshi
(87) International Publication No	: NA	
(61) Patent of Addition to Application Number:	NA	
Filing Date	:NA	
(62) Divisional to Application Number	:NA	
Filing Date	:NA	

(57) Abstract :

The present invention provides a novel and simple process for scale on-site production of microbes for oil & gas fields comprising culture of desired microorganisms in huge volume by deployment of already existing provisions and resources normally available at the well site. This process is easy to apply and modulate. It involves less moving parts and hence their maintenance is significantly low. The parts are modular and can be carried to the well-site for on-site culturing of microbes. The process for scale on-site production of microbes is customizable can be applied at different locations at the same time.

No. of Pages : 16 No. of Claims : 8

Publication After 18 Months:

The following Patent Applications have been published under Section 11A (3) of The Patents (Amendment) Act, 2005. Any Person may file representation by way of opposition to the Controller of Patents at the appropriate office against the grant of the patent in the prescribed manner under section 25(1) of the Patents (Amendment) Act, 2005 read with the rule 55 of The Patents (Amendment) Rules, 2006:

(12) PATENT APPLICATION PUBLICATION

(21) Application No.201911049845 A

(19) INDIA

(22) Date of filing of Application :04/12/2019

(43) Publication Date : 11/06/2021

(54) Title of the invention : A CHEMICAL COMPOSITION FOR DETECTION OF FURFURAL AND HYDROXYMETHYLFURFURAL IN FOOD COMMODITIES AND PROCESS FOR DETECTION THEREOF

(51) International classification	:C07D0307500000, C07D0307460000, C07D0307480000, G01N0033020000, C08G0008040000	(71)Name of Applicant : 1)COUNCIL OF SCIENTIFIC AND INDUSTRIAL RESEARCH Address of Applicant :ANUSANDHAN BHAWAN, 2 RAFI MARG NEW DELHI-110001, INDIA Delhi India
(31) Priority Document No	:NA	(72)Name of Inventor :
(32) Priority Date	:NA	1)SRISHTI MEHROTRA
(33) Name of priority country	:NA	2)PAWAN KUMAR RAI
(86) International Application No	:NA	3)SANDEEP KUMAR SHARMA
Filing Date	:NA	
(87) International Publication No	: NA	
(61) Patent of Addition to Application Number	:NA	
Filing Date	:NA	
(62) Divisional to Application Number	:NA	
Filing Date	:NA	

(57) Abstract :

Furfural and hydroxymethylfurfural (HMF) are formed in food as a result of maillard reaction indicating the degradation of food products. They are also present as a byproduct of sugar degradation in oils and lignocellulosic biomass and hamper the quality and biofuel yield. The present invention provides a novel and rapid quantitative method for their detection in complex matrices. The solution after the reaction changes colour to deep red for furfural and orange for HMF. The said change in colour can be detected spectrophotometrically at 530 nm. The method omits sample processing and quantitates furfural and HMF with LOD of 0.002% (v/v) in fruit juice and 0.004% (v/v) in seed oils.

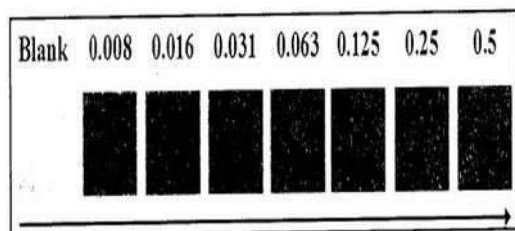

No. of Pages : 13 No. of Claims : 3

(54) Title of the invention : FROTHY PRESSURISED BEVERAGE IN A CAN

(51) International classification	:A23F0005240000, A23C0009154000, A23L0002020000, A23C0009152000, B65D0085730000	(71)Name of Applicant : 1)RAHUL GIDWANI Address of Applicant :H.NO.-405/11, LALITA PARK LAXMI NAGAR DELHI NEW DELHI-110092, INDIA Delhi India
(31) Priority Document No	:NA	(72)Name of Inventor :
(32) Priority Date	:NA	1)RAHUL GIDWANI
(33) Name of priority country	:NA	
(86) International Application No	:NA	
Filing Date	:NA	
(87) International Publication No	: NA	
(61) Patent of Addition to Application Number:	NA	
Filing Date	:NA	
(62) Divisional to Application Number	:NA	
Filing Date	:NA	

(57) Abstract :

A process of pressurised packaged liquid beverage in a sealed container once opened produces a frothy/foamy ready to drink beverage. This process includes partially filling a container with liquid beverage leaving a place for a small tube on top that is closed from below and open from above supported by branches/handles that mounts on top of container on its edges introducing a volume of gas in liquid/solid form inside the small tube before sealing the container and agitating the liquid beverage inside the sealed container. When the container is opened, the liquid beverage increases in volume and separates into liquid phase and a drinkable foam phase. The small tube used to avoid gas in liquid/Solid ice form to quickly vaporise allowing extra time to seal the container that helps in agitation of gas with the liquid beverage once container is sealed/sealed. The liquid beverage may include milk, coffee, iced tea (base as water), fruit juice, smoothies or mixtures thereof, particularly mixtures of milk and coffee, and may further include a gum. The gas may be nitrous oxide(N₂O).

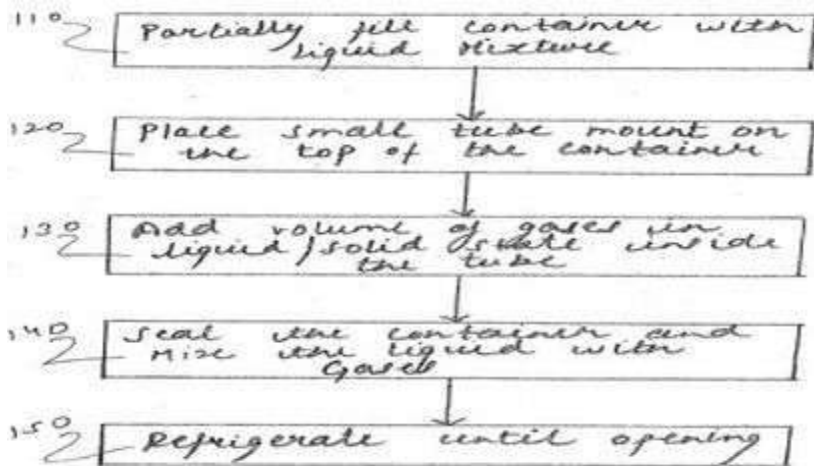

No. of Pages : 37 No. of Claims : 16

(54) Title of the invention : METHOD FOR ALERT SYSTEM TO DETECT RADIATION EMERGENCY DOSES

(51) International classification :G06K0009000000,
G06K0009620000,
G07D0007120000,
G06K0009480000,
G06K0009380000

(31) Priority Document No :NA
(32) Priority Date :NA
(33) Name of priority country :NA
(86) International Application No :NA
Filing Date :NA
(87) International Publication No : NA
(61) Patent of Addition to Application Number :NA
Filing Date :NA
(62) Divisional to Application Number :NA
Filing Date :NA

(71)**Name of Applicant :**
1)Chairman, Defence Research & Development Organisation
Address of Applicant :Ministry of Defence, Govt of India,
Room No 348, B - Wing, DRDO Bhawan, Rajaji Marg, New
Delhi 110 011, India, Delhi India

(72)**Name of Inventor :**
1)Shukla, Sandeep Kumar
2)Sharma, Ajay Kumar
3)Singh, Sukhvir
4)Goswami, Pradeep
5)Manda, Kailash
6)Kalonja, Aman
7)Shaw, Priyanka

(57) Abstract :

A device (100) and a method for determining amount of radiation in an environment are described. Multiple images of an environment may be captured using a camera of the device (100), for a predefined time period. The images may be converted into greyscale images. For each of the greyscale images, value of each pixel present in a greyscale image may be compared with average values of surrounding pixels, and the greyscale images may be converted into binary images based on the comparison. Flash spots, generated by ionization electrons, present in each binary image may be identified. A quantity of radiation present in the environment may be determined based on a count of the flash spots.

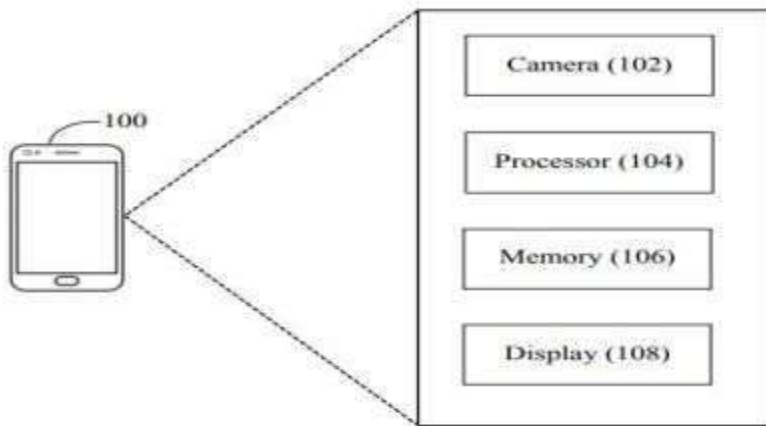

No. of Pages : 22 No. of Claims : 10

(12) PATENT APPLICATION PUBLICATION

(21) Application No.201911049980 A

(19) INDIA

(22) Date of filing of Application :04/12/2019

(43) Publication Date : 11/06/2021

(54) Title of the invention : BENZOTHIADIAZEPINE COMPOUNDS AND THEIR USE AS BILE ACID MODULATORS •

(51) International classification	:C07D0285360000, A61K0031554000, C07D0417120000, C07D0487080000, A61K0031498500	(71) Name of Applicant : 1)Albireo AB Address of Applicant :Arvid Wallgrens backe 20, 413 46 Gteborg, Sweden Sweden
(31) Priority Document No	:NA	(72) Name of Inventor :
(32) Priority Date	:NA	1)GILLBERG, Per-Gran
(33) Name of priority country	:NA	2)STARKE, Ingemar
(86) International Application No	:NA	3)KULKARNI, Santosh S.
Filing Date	:NA	
(87) International Publication No	: NA	
(61) Patent of Addition to Application Number	:NA	
Filing Date	:NA	
(62) Divisional to Application Number	:NA	
Filing Date	:NA	

(57) Abstract :

The invention relates to 1,2,5-benzothiadiazepine derivatives of formula (I). These compounds are bile acid modulators having apical sodium-dependent bile acid transporter (ASBT) and/or liver bile acid transport (LBAT) inhibitory activity. The invention also relates to pharmaceutical compositions comprising these compounds and to the use of these compounds in the treatment of cardiovascular diseases, fatty acid metabolism and glucose utilization disorders, gastrointestinal diseases and liver diseases.

No. of Pages : 125 No. of Claims : 15

(54) Title of the invention : BENZOTHIADIAZEPINE COMPOUNDS AND THEIR USE AS BILE ACID MODULATORS •

(51) International classification	:C07D0285360000, A61K0031554000, C07D0417120000, C07D0487080000, A61K0031498500	(71) Name of Applicant : 1)Albireo AB Address of Applicant :Arvid Wallgrens backe 20, 413 46 Gteborg, Sweden Sweden
(31) Priority Document No	:NA	(72) Name of Inventor :
(32) Priority Date	:NA	1)GILLBERG, Per-Gran
(33) Name of priority country	:NA	2)STARKE, Ingemar
(86) International Application No	:NA	3)KULKARNI, Santosh S.
Filing Date	:NA	4)MATTSSON, Jan
(87) International Publication No	: NA	
(61) Patent of Addition to Application Number	:NA	
Filing Date	:NA	
(62) Divisional to Application Number	:NA	
Filing Date	:NA	

(57) Abstract :

The invention relates to 1,2,5-benzothiadiazepine derivatives of formula (I). These compounds are bile acid modulators having apical sodium-dependent bile acid transporter (ASBT) and/or liver bile acid transport (LBAT) inhibitory activity. The invention also relates to pharmaceutical compositions comprising these compounds and to the use of these compounds in the treatment of cardiovascular diseases, fatty acid metabolism and glucose utilization disorders, gastrointestinal diseases and liver diseases.

No. of Pages : 139 No. of Claims : 15

(12) PATENT APPLICATION PUBLICATION

(21) Application No.201911049982 A

(19) INDIA

(22) Date of filing of Application :04/12/2019

(43) Publication Date : 11/06/2021

(54) Title of the invention : BENZOTHIA(DI)AZEPINE COMPOUNDS AND THEIR USE AS BILE ACID MODULATORS •

(51) International classification	:C07D0285360000, A61K0031554000, C07D0281100000, C07D0417120000, C07D0487080000	(71) Name of Applicant : 1)Albireo AB Address of Applicant :Arvid Wallgrens backe 20, 413 46 Gteborg, Sweden Sweden
(31) Priority Document No	:NA	(72) Name of Inventor :
(32) Priority Date	:NA	1)GILLBERG, Per-Gran
(33) Name of priority country	:NA	2)STARKE, Ingemar
(86) International Application No	:NA	3)KULKARNI, Santosh S.
Filing Date	:NA	
(87) International Publication No	: NA	
(61) Patent of Addition to Application Number	:NA	
Filing Date	:NA	
(62) Divisional to Application Number	:NA	
Filing Date	:NA	

(57) Abstract :

The invention relates to 1,5-benzothiazepine and 1,2,5-benzothiadiazepine derivatives of formula (I). These compounds are bile acid modulators having apical sodium-dependent bile acid transporter (ASBT) and/or liver bile acid transport (LBAT) inhibitory activity. The invention also relates to pharmaceutical compositions comprising these compounds and to the use of these compounds in the treatment of cardiovascular diseases, fatty acid metabolism and glucose utilization disorders, gastrointestinal diseases and liver diseases.

No. of Pages : 150 No. of Claims : 15

(12) PATENT APPLICATION PUBLICATION

(21) Application No.201911049983 A

(19) INDIA

(22) Date of filing of Application :04/12/2019

(43) Publication Date : 11/06/2021

(54) Title of the invention : BENZOTHIA(DI)AZEPINE COMPOUNDS AND THEIR USE AS BILE ACID MODULATORS •

(51) International classification	:C07D0285360000, A61K0031554000, C07D0281100000, C07D0417120000, C07D0487080000	(71) Name of Applicant : 1)Albireo AB Address of Applicant :Arvid Wallgrens backe 20, 413 46 Gteborg, Sweden Sweden
(31) Priority Document No	:NA	(72) Name of Inventor :
(32) Priority Date	:NA	1)GILLBERG, Per-Gran
(33) Name of priority country	:NA	2)STARKE, Ingemar
(86) International Application No	:NA	3)KULKARNI, Santosh S.
Filing Date	:NA	
(87) International Publication No	: NA	
(61) Patent of Addition to Application Number	:NA	
Filing Date	:NA	
(62) Divisional to Application Number	:NA	
Filing Date	:NA	

(57) Abstract :

The invention relates to 1,5-benzothiazepine and 1,2,5-benzothiadiazepine derivatives of formula (I). These compounds are bile acid modulators having apical sodium-dependent bile acid transporter (ASBT) and/or liver bile acid transport (LBAT) inhibitory activity. The invention also relates to pharmaceutical compositions comprising these compounds and to the use of these compounds in the treatment of cardiovascular diseases, fatty acid metabolism and glucose utilization disorders, gastrointestinal diseases and liver diseases.

No. of Pages : 142 No. of Claims : 15

(12) PATENT APPLICATION PUBLICATION

(21) Application No.201911049984 A

(19) INDIA

(22) Date of filing of Application :04/12/2019

(43) Publication Date : 11/06/2021

(54) Title of the invention : BENZOTHIA(DI)AZEPINE COMPOUNDS AND THEIR USE AS BILE ACID MODULATORS •

(51) International classification	:C07D0285360000, A61K0031554000, C07D0281100000, C07D0417120000, C07D0487080000	(71) Name of Applicant : 1)Albireo AB Address of Applicant :Arvid Wallgrens backe 20, 413 46 Gteborg, Sweden Sweden
(31) Priority Document No	:NA	(72) Name of Inventor :
(32) Priority Date	:NA	1)GILLBERG, Per-Gran
(33) Name of priority country	:NA	2)STARKE, Ingemar
(86) International Application No	:NA	3)KULKARNI, Santosh S.
Filing Date	:NA	
(87) International Publication No	: NA	
(61) Patent of Addition to Application Number	:NA	
Filing Date	:NA	
(62) Divisional to Application Number	:NA	
Filing Date	:NA	

(57) Abstract :

The invention relates to certain 1,5-benzothiazepine and 1,2,5-benzothiadiazepine derivatives as defined herein. These compounds are bile acid modulators having apical sodium-dependent bile acid transporter (ASBT) and/or liver bile acid transport (LBAT) inhibitory activity. The invention also relates to pharmaceutical compositions comprising these compounds and to the use of these compounds in the treatment of cardiovascular diseases, fatty acid metabolism and glucose utilization disorders, gastrointestinal diseases and liver diseases.

No. of Pages : 154 No. of Claims : 8

(12) PATENT APPLICATION PUBLICATION

(21) Application No.201911049985 A

(19) INDIA

(22) Date of filing of Application :04/12/2019

(43) Publication Date : 11/06/2021

(54) Title of the invention : BENZOTHIAZEPINE COMPOUNDS AND THEIR USE AS BILE ACID MODULATORS •

(51) International classification	:C07D0281100000, A61K0031554000, C07D0417120000, C07D0487080000, A61K0031498500	(71) Name of Applicant : 1)Albireo AB Address of Applicant :Arvid Wallgrens backe 20, 413 46 Gteborg, Sweden Sweden
(31) Priority Document No	:NA	(72) Name of Inventor :
(32) Priority Date	:NA	1)GILLBERG, Per-Gran
(33) Name of priority country	:NA	2)STARKE, Ingemar
(86) International Application No	:NA	3)KULKARNI, Santosh S.
Filing Date	:NA	
(87) International Publication No	: NA	
(61) Patent of Addition to Application Number	:NA	
Filing Date	:NA	
(62) Divisional to Application Number	:NA	
Filing Date	:NA	

(57) Abstract :

The invention relates to 1,5-benzothiazepine derivatives of formula (I). These compounds are bile acid modulators having apical sodium-dependent bile acid transporter (ASBT) and/or liver bile acid transport (LBAT) inhibitory activity. The invention also relates to pharmaceutical compositions comprising these compounds and to the use of these compounds in the treatment of cardiovascular diseases, fatty acid metabolism and glucose utilization disorders, gastrointestinal diseases and liver diseases.

No. of Pages : 159 No. of Claims : 15

(12) PATENT APPLICATION PUBLICATION

(21) Application No.201911049986 A

(19) INDIA

(22) Date of filing of Application :04/12/2019

(43) Publication Date : 11/06/2021

(54) Title of the invention : BENZOTHIAZEPINE COMPOUNDS AND THEIR USE AS BILE ACID MODULATORS •

(51) International classification	:C07D0281100000, A61K0031554000, C07D0417120000, C07D0487080000, A61K0031498500	(71) Name of Applicant : 1)Albireo AB Address of Applicant :Arvid Wallgrens backe 20, 413 46 Gteborg, Sweden Sweden
(31) Priority Document No	:NA	(72) Name of Inventor :
(32) Priority Date	:NA	1)GILLBERG, Per-Gran
(33) Name of priority country	:NA	2)STARKE, Ingemar
(86) International Application No	:NA	3)KULKARNI, Santosh S.
Filing Date	:NA	4)MATTSSON, Jan
(87) International Publication No	: NA	
(61) Patent of Addition to Application Number	:NA	
Filing Date	:NA	
(62) Divisional to Application Number	:NA	
Filing Date	:NA	

(57) Abstract :

The invention relates to 1,5-benzothiazepine derivatives of formula (I). These compounds are bile acid modulators having apical sodium-dependent bile acid transporter (ASBT) and/or liver bile acid transport (LBAT) inhibitory activity. The invention also relates to pharmaceutical compositions comprising these compounds and to the use of these compounds in the treatment of cardiovascular diseases, fatty acid metabolism and glucose utilization disorders, gastrointestinal diseases and liver diseases.

No. of Pages : 174 No. of Claims : 14

(54) Title of the invention : SYSTEM AND METHOD FOR OPTIMIZING ENERGY CONSUMPTION IN A GOODS COMPARTMENT OF DELIVERY VEHICLES

(51) International classification :G06Q0010080000,
B60H0001000000,
G06Q0050120000,
G05B0019418000,
G05D0023190000

(31) Priority Document No :NA
(32) Priority Date :NA
(33) Name of priority country :NA
(86) International Application No :NA
Filing Date :NA
(87) International Publication No : NA
(61) Patent of Addition to Application Number :NA
Filing Date :NA
(62) Divisional to Application Number :NA
Filing Date :NA

(71)**Name of Applicant :**
1)Daimler AG
Address of Applicant :70546 Stuttgart Germany Germany

(72)**Name of Inventor :**
1)Mr. Sashank Vedula
2)Mr. Vivek Prahlada
3)Mr. Divas Bahuguna
4)Mr. Ayush Choubey

(57) Abstract :

A system 100 and method for thermal management of a goods compartment of a delivery vehicle is disclosed being based on determining a speed profile for the delivery vehicle along a predefined route, determining duration of time taken by the vehicle to reach next delivery location from a preceding stopping location; predicting, based on attributes of the goods to be delivered at the next delivery location, a time of interaction of inside of the goods compartment of the delivery vehicle with the ambient, at the next delivery location; and determining a location before the next delivery location to deactivate a cooling unit configured with the goods compartment without allowing temperature of the stored goods exceeding a threshold temperature until the vehicle reaches the next delivery location to facilitate optimum utilisation of energy for cooling while maintain minimum amount of cooling required to keep the goods in health.

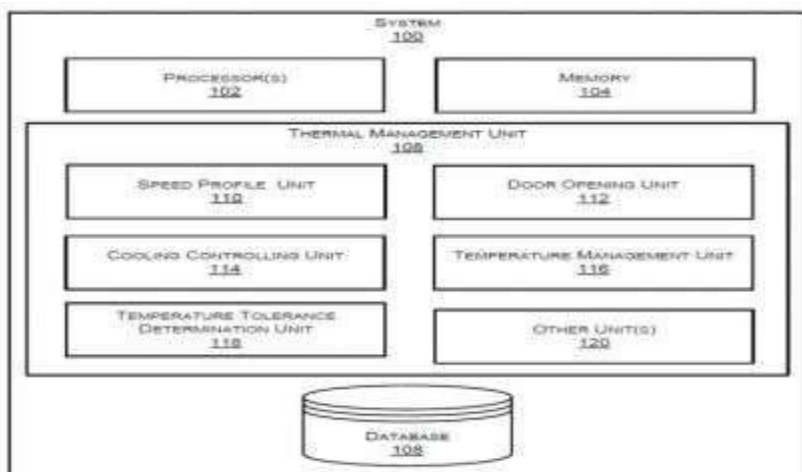

No. of Pages : 26 No. of Claims : 10

(54) Title of the invention : DEVICE FOR DEVELOPING GERMFREE AND GNOTOBIOTIC MOSQUITOES

(51) International classification	:A61B0017000000, C12M0001120000, C12M0001000000, F16C0033660000, B26B0019380000	(71) Name of Applicant : 1)INDIAN COUNCIL OF MEDICAL RESEARCH Address of Applicant :V. Ramalingaswami Bhawan, P.O. Box No. 4911, Ansari Nagar, New Delhi - 110029, India Delhi India
(31) Priority Document No	:NA	(72) Name of Inventor :
(32) Priority Date	:NA	1)M. Muniaraj
(33) Name of priority country	:NA	
(86) International Application No	:NA	
Filing Date	:NA	
(87) International Publication No	: NA	
(61) Patent of Addition to Application Number	:NA	
Filing Date	:NA	
(62) Divisional to Application Number	:NA	
Filing Date	:NA	

(57) Abstract :

The present invention relates to a device (10) for rearing and incubation of germfree and gnotobiotic insects in a controlled environment. The device (10) comprises of a support structure (11) having an interior space (12), a non-porous cover (13) configured to cover the support structure, a closure device (14) configured to close an opening (15) of the non-porous cover (13) wherein said support structure (11) is provided with a neck like provision(16) for fixing a porous element (17) configured to close the opening of said support structure (11) and allowing sterilized air to pass through it.

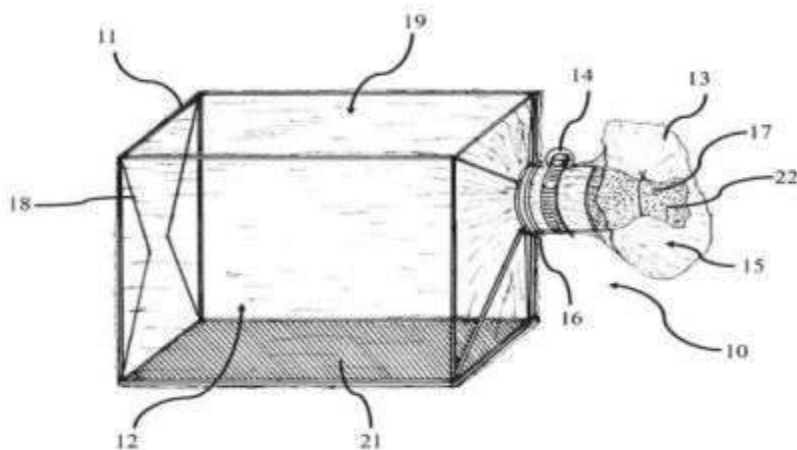

No. of Pages : 27 No. of Claims : 12

(54) Title of the invention : AN ARRANGEMENT FOR AIR FLOW IN A CONVERTIBLE REFRIGERATOR

(51) International classification :F25D0017060000,
F25D0011020000,
H05K0007200000,
F04D0029600000,
F25D0013060000

(31) Priority Document No :NA
(32) Priority Date :NA
(33) Name of priority country :NA
(86) International Application No :NA
Filing Date :NA
(87) International Publication No : NA
(61) Patent of Addition to Application Number:NA
Filing Date :NA
(62) Divisional to Application Number :NA
Filing Date :NA

(71)**Name of Applicant :**
1)LG ELECTRONICS INC.
Address of Applicant :20 Yeouido-dong, Yeongdeungpo-gu,
Seoul 150-721, Republic of Korea Republic of Korea

(72)**Name of Inventor :**
1)Agrawal Saurabh
2)Singh Amar

(57) Abstract :

An arrangement (100) for air flow in a convertible refrigerator is provided. The arrangement (100) comprises a freezer compartment (102), a refrigeration compartment (304), a permanent freezer compartment (110), a grill fan assembly (202), a plurality of fan units (104, 106) and a duct channel assembly (108) . The permanent freezer compartment (110) is provided inside the freezer compartment (102) . The grill fan assembly (202) is provided for blowing air into the freezer compartment (102) . The plurality of fan units (104, 106) are provided inside the grill fan assembly (202) for blowing cool air into the freezer compartment (102) and the refrigeration compartment (304) . The duct channel assembly (108) is provided for passing the cool air from the plurality of fan units (104, 106) of the grill fan assembly (202) to the refrigeration compartment (304) and the freezer compartment (102) to maintain the temperature.

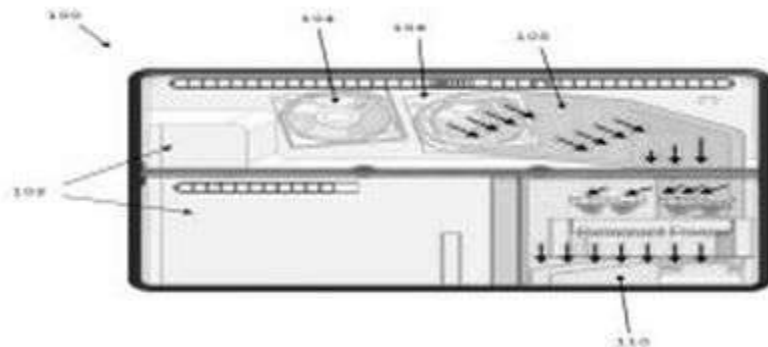

FIGURE 1

No. of Pages : 24 No. of Claims : 29

(54) Title of the invention : AN ARRANGEMENT FOR COOLING A HYBRID DOUBLE DOOR CONVERTIBLE REFRIGERATOR

(51) International classification :F25D0017060000,
F25D0029000000,
F25D0011020000,
F25B0021020000,
B60R0016033000

(31) Priority Document No :NA
(32) Priority Date :NA
(33) Name of priority country :NA
(86) International Application No :NA
Filing Date :NA
(87) International Publication No : NA
(61) Patent of Addition to Application Number:NA
Filing Date :NA
(62) Divisional to Application Number :NA
Filing Date :NA

(71)**Name of Applicant :**
1)LG ELECTRONICS INC.
Address of Applicant :20 Yeouido-dong, Yeongdeungpo-gu,
Seoul 150-721, Republic of Korea Republic of Korea

(72)**Name of Inventor :**
1)Agrawal Praveen
2)Kumar Sachin

(57) Abstract :

An arrangement (100) for cooling a hybrid double door convertible refrigerator (102) is provided. The arrangement (100) comprises a freezer compartment (104), a refrigeration compartment (106), Vapor Compression Refrigerator System VCRS (110), a peltier module (112), a plurality of sensors and an electrical assembly (306) . The plurality of sensors provided inside the hybrid double door convertible refrigerator (102) to detect the temperature of the freezer compartment (104) and the refrigeration compartment (106) . The electrical assembly is mounted on a printed circuit board (PCB) assembly to provide control on the operations of the VCRS (110) and the peltier module (112) of the hybrid double door convertible refrigerator (102). The freezer compartment (104) is cooled by the VCRS (110) and the refrigeration compartment (106) is cooled by the peltier module (112) separately.

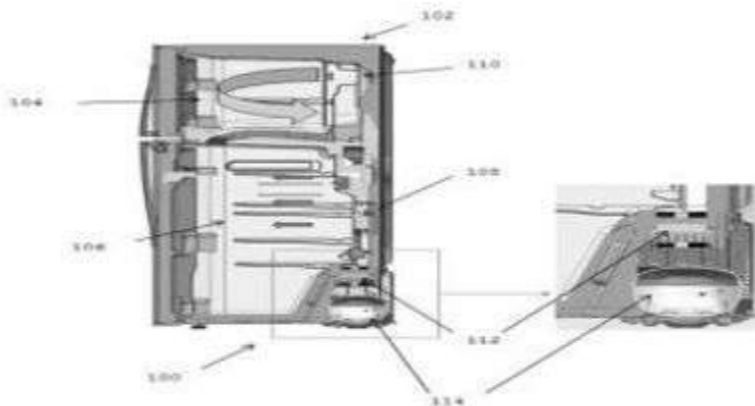

No. of Pages : 21 No. of Claims : 31

(54) Title of the invention : A THERMALLY EFFICIENT OVER-EXPANSION STROKE BASED ENGINE

(51) International classification	:F02D0041380000, G06K0009000000, F02B0047020000, G06T0011200000, G16H0050300000	(71) Name of Applicant : 1)INDIAN INSTITUTE OF TECHNOLOGY (BANARAS HINDU UNIVERSITY), VARANASI Address of Applicant :Varanasi-221005, Uttar Pradesh, India Uttar Pradesh India
(31) Priority Document No	:NA	(72) Name of Inventor :
(32) Priority Date	:NA	1)JEEWAN VACHAN TIRKEY
(33) Name of priority country	:NA	2)SHAILENDRA KUMAR SHUKLA
(86) International Application No	:NA	
Filing Date	:NA	
(87) International Publication No	: NA	
(61) Patent of Addition to Application Number:	NA	
Filing Date	:NA	
(62) Divisional to Application Number	:NA	
Filing Date	:NA	

(57) Abstract :

The present invention relates to an over-expansion stroke based engine with an eccentric crankshaft to increase thermal efficiency as well as brake mean effective pressure and decrease the fuel consumption. The over-expansion stroke based engine comprises of a cylinder, a piston, a slotted crank, a crankshaft, and a fixed gear.

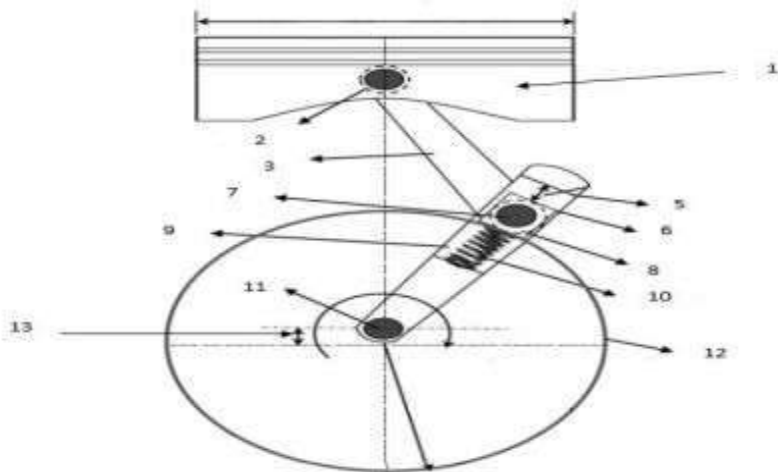

No. of Pages : 15 No. of Claims : 5

(54) Title of the invention : A POROUS SCAFFOLD COMPOSITION FOR TISSUE REGENERATION AND METHOD OF PREPARING THE SAME

(51) International classification	:A61L0027560000, A61L0027380000, A61L0027580000, A61L0027540000, A61K0031728000	(71) Name of Applicant : 1)BIRLA INSTITUTE OF TECHNOLOGY & SCIENCE (BITS), PILANI Address of Applicant :Birla Institute of Technology & Science (BITS), Pilani, Pilani Campus, Vidya Vihar, Pilani, Jhunjunu District, Rajasthan 333031, India. Rajasthan India
(31) Priority Document No	:NA	(72) Name of Inventor :
(32) Priority Date	:NA	1)Aniruddha Roy
(33) Name of priority country	:NA	2)Swati Sharma
(86) International Application No	:NA	
Filing Date	:NA	
(87) International Publication No	: NA	
(61) Patent of Addition to Application Number	:NA	
Filing Date	:NA	
(62) Divisional to Application Number	:NA	
Filing Date	:NA	

(57) Abstract :

A porous scaffold composition for tissue regeneration and method of preparing the same The present invention relates to porous scaffold composition for tissue regeneration. The composition comprises a polyelectrolyte complex of three polymers i.e. chitosan, chondroitin sulfate and hyaluronic acid. The scaffold is formed spontaneously in-situ upon mixing of the three polymers. Cells can be completely engrafted into the scaffold by mixing the cells with the polymer solutions at the time of forming the scaffold.

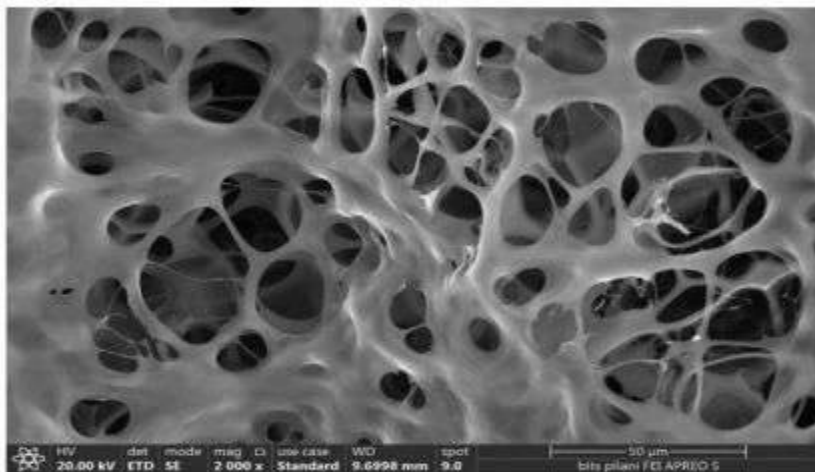

No. of Pages : 27 No. of Claims : 15

(12) PATENT APPLICATION PUBLICATION

(21) Application No.201911050076 A

(19) INDIA

(22) Date of filing of Application :05/12/2019

(43) Publication Date : 11/06/2021

(54) Title of the invention : PERSON IDENTIFICATION AND IMPOSTER DETECTION USING FOOTFALL GENERATED SEISMIC SIGNALS

(51) International classification	:G06K0009000000, G06K0009620000, G06F0021320000, G11B0020100000, G07C0009000000	(71) Name of Applicant : 1)INDIAN INSTITUTE OF TECHNOLOGY DELHI Address of Applicant :Hauz Khas, New Delhi - 110016 Delhi India
(31) Priority Document No	:NA	(72) Name of Inventor :
(32) Priority Date	:NA	1)KAR, Subrat
(33) Name of priority country	:NA	2)MUKHOPADHYAY, Bodhibrata
(86) International Application No	:NA	3)ANCHAL, Sahil
Filing Date	:NA	
(87) International Publication No	: NA	
(61) Patent of Addition to Application Number	:NA	
Filing Date	:NA	
(62) Divisional to Application Number	:NA	
Filing Date	:NA	

(57) Abstract :

A smart device, biometric authentication system and a corresponding method thereof for person identification and imposter detection has been disclosed. The method comprises detection and extraction of seismic signals generated from corresponding footfalls, by means of unsupervised learning based detection and extraction module (USLEEM) and detection and identification of imposter and/or registered users respectively by means of an identification module.

No. of Pages : 40 No. of Claims : 9

(12) PATENT APPLICATION PUBLICATION

(21) Application No.201911050077 A

(19) INDIA

(22) Date of filing of Application :05/12/2019

(43) Publication Date : 11/06/2021

(54) Title of the invention : MULTI - PERSON TRACKING USING APPEARANCE SEARCH

(51) International classification	:G06K0009000000, G09B0019000000, G06F0016583000, G06T0011600000, H04B0007080000	(71) Name of Applicant : 1)Sanjay Sinha Address of Applicant :Star Tower, 610, 6th Floor, Sector - 30, Gurugram, Haryana Haryana India
(31) Priority Document No	:NA	(72) Name of Inventor :
(32) Priority Date	:NA	1)Seshadri Sastry Kunapuli
(33) Name of priority country	:NA	2)Praveen Chakravarthy
(86) International Application No	:NA	3)Upasana Singh
Filing Date	:NA	4)S Ravi Kumar
(87) International Publication No	: NA	5)Kritika Thakur
(61) Patent of Addition to Application Number	:NA	
Filing Date	:NA	
(62) Divisional to Application Number	:NA	
Filing Date	:NA	

(57) Abstract :

One shot(using only one training example) recognition of person based on his/her overall appearance.

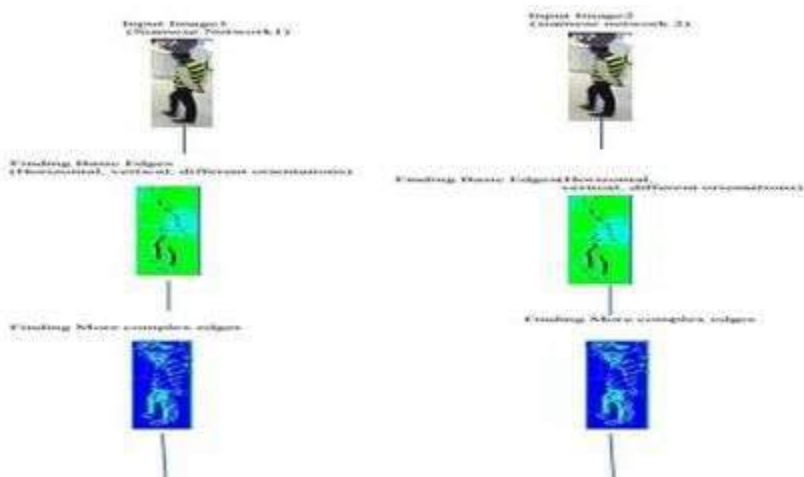

No. of Pages : 6 No. of Claims : 3

(12) PATENT APPLICATION PUBLICATION

(21) Application No.201911050078 A

(19) INDIA

(22) Date of filing of Application :05/12/2019

(43) Publication Date : 11/06/2021

(54) Title of the invention : CROWD COUNTING IN EMPORIUM USING CONVNETS

(51) International classification	:G08G0001040000, G06Q0030020000, G06T0007246000, H04N0007140000, G16H0010600000	(71) Name of Applicant : 1)Sanjay Sinha Address of Applicant :Star Tower, 610, 6th Floor, Sector 30, Gurugram, Haryana, India Haryana India
(31) Priority Document No	:NA	(72) Name of Inventor :
(32) Priority Date	:NA	1)Seshadri Sastry Kunapuli
(33) Name of priority country	:NA	2)Praveen Chakravarthy
(86) International Application No	:NA	3)Upasana Singh
Filing Date	:NA	4)S Ravi Kumar
(87) International Publication No	: NA	5)Kritika Thakur
(61) Patent of Addition to Application Number	:NA	
Filing Date	:NA	
(62) Divisional to Application Number	:NA	
Filing Date	:NA	

(57) Abstract :

Count the number of person present in an emporium or retail store at a particular time using single camera.

No. of Pages : 8 No. of Claims : 4

(54) Title of the invention : A VISUAL CONCENTRIC APPEARANCE APPROACH ON DESIGNING WEAPONS-NET • FOR DETECTING WEAPONS FOR UNIVERSAL CAMERAS

(51) International classification	:G06N0020000000, G06K0009000000, A01K0067027000, H04N0007180000, G09B0009000000	(71)Name of Applicant : 1)Sanjay Sinha Address of Applicant :Star Tower, 610, 6th Floor, Sector 30, Gurugram, Haryana Haryana India
(31) Priority Document No	:NA	(72)Name of Inventor : 1)Seshadri Sastry Kunapuli
(32) Priority Date	:NA	2)Praveen Chakravarthy
(33) Name of priority country	:NA	3)Upasana Singh
(86) International Application No	:NA	4)S Ravi Kumar
Filing Date	:NA	5)Kritika Thakur
(87) International Publication No	: NA	
(61) Patent of Addition to Application Number	:NA	
Filing Date	:NA	
(62) Divisional to Application Number	:NA	
Filing Date	:NA	

(57) Abstract :

1) Real time Automatic Weapon Detection model which can detect up to 20 categories of weapons even with low-resolution cameras under any illuminations. 2) Alarming the officials through Mail with a video in any public, private zones (e.g., Banks, Retail Stores etc.) 3) Utilization of Smart Cameras is not required. 4) Any official can visualize this video in the database even after months, if it™s required. 5) This Weapons-net • model is similar to the other Existing Deep Learning models such as Google Net • , MXNet • , and Alex Net • , which can be used by anyone for detecting any kind of weapons in the real time scenario (for any zone, it is not a camera based AI model). 6) No human Intervention is required to continuously monitor the cameras

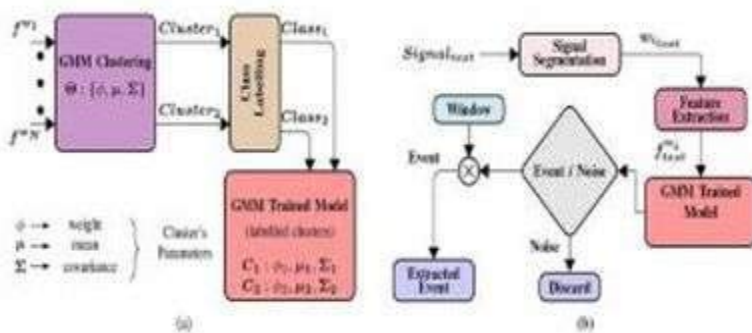

Figure 2

No. of Pages : 4 No. of Claims : 2

(54) Title of the invention : VEHICLE

(51) International classification :E02F0003320000,
B60K0006480000,
B62J0035000000,
B60K0015063000,
E02F0009080000

(31) Priority Document No :NA
(32) Priority Date :NA
(33) Name of priority country :NA
(86) International Application No :NA
Filing Date :NA
(87) International Publication No : NA
(61) Patent of Addition to Application Number :NA
Filing Date :NA
(62) Divisional to Application Number :NA
Filing Date :NA

(71)**Name of Applicant :**
1)Hero MotoCorp Limited
Address of Applicant :The Grand Plaza, Plot No.2, Nelson
Mandela Road, Vasant Kunj- Phase II, New Delhi Delhi Delhi
India

(72)**Name of Inventor :**
1)AHMED, Hejaz
2)KOTHARI, Manish

(57) Abstract :

An electrical component protection system is disclosed. The vehicle (100) comprising a frame (300), an engine (9) and a cover member (200) mounted on the frame (300). The fuel tank (13) mounted above the engine (9). The electrical component (250) disposed above the engine (9) and under the fuel tank (13). The electrical component (250) comprises a plurality of potting portions (240, 242, 244, 246). Restricting the access of the potting portions (240, 242, 244, 246) of the electrical component (250) via the cover member (200).

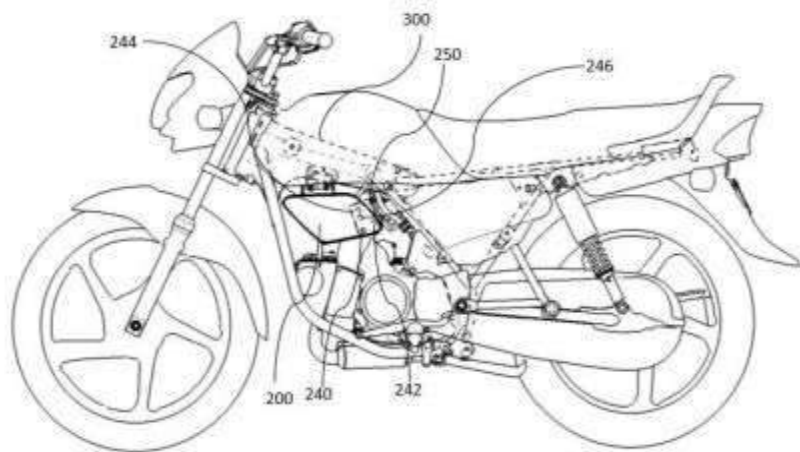

No. of Pages : 16 No. of Claims : 3

(54) Title of the invention : EXHAUST SYSTEM

(51) International classification :F01N0013080000,
B60K0013040000,
F01N0013180000,
F01N0013000000,
F01N0003021000

(31) Priority Document No :NA
(32) Priority Date :NA
(33) Name of priority country :NA
(86) International Application No :NA
Filing Date :NA
(87) International Publication No : NA
(61) Patent of Addition to Application Number:NA
Filing Date :NA
(62) Divisional to Application Number :NA
Filing Date :NA

(71)**Name of Applicant :**
1)Hero MotoCorp Limited
Address of Applicant :The Grand Plaza, Plot No.2, Nelson
Mandela Road, Vasant Kunj- Phase -II, New Delhi Delhi India

(72)**Name of Inventor :**
1)MISHRA, Abhishek
2)DUBEY, Shubham

(57) Abstract :

In one aspect of the present invention, a vehicle (100) is provided. The vehicle (100) comprising a frame (200); an internal combustion engine (300) swingably mounted to the frame (200) through the engine mounting system (400); an engine cooling fan unit (316) mounted to the internal combustion engine (300); and an exhaust system (500) mounted on the frame (200). The exhaust system (500) comprising: an exhaust pipe (301) comprising a first bent portion (302), a second bent portion (303), and a tail pipe (330), a second exhaust gas purification device (304a) positioned on a downstream end of the tail pipe (330), a muffler device (307) connected to the second exhaust gas purification device (304a). The second exhaust gas purification device (304a). The tail pipe (330) is positioned at a predetermined distance below the engine cooling fan unit (316).

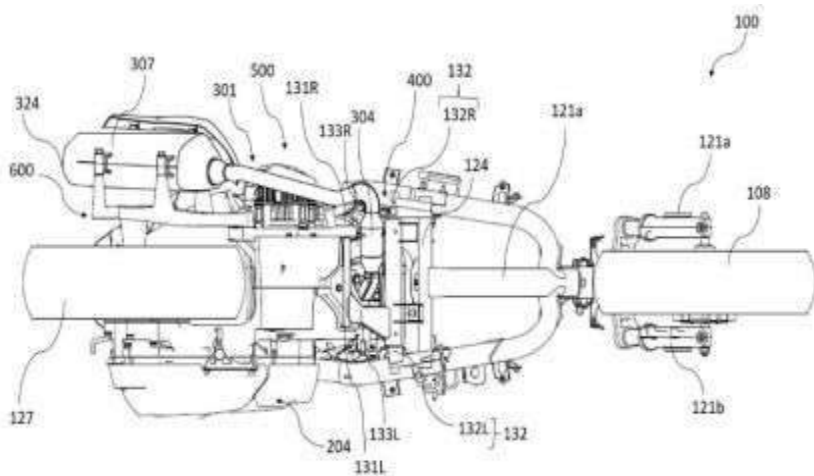

No. of Pages : 30 No. of Claims : 8

(54) Title of the invention : AMINES AND ENERGETIC SALTS OF NITRATED PYRROLES

(51) International classification :C07D0207340000,
C07D0471040000,
G01N0033520000,
C40B0060140000,
C07D0207333000

(31) Priority Document No :NA
(32) Priority Date :NA
(33) Name of priority country :NA
(86) International Application No :NA
Filing Date :NA
(87) International Publication No : NA
(61) Patent of Addition to Application Number :NA
Filing Date :NA
(62) Divisional to Application Number :NA
Filing Date :NA

(71)Name of Applicant :
1)CHAIRMAN, DEFENCE RESEARCH & DEVELOPMENT ORGANISATION
Address of Applicant :Ministry Of Defence, Govt. Of India,
Room No 348, B-Wing, DRDO Bhawan, Rajaji Marg, New Delhi
110011, India Delhi India
2)ACRHEM, HYDERABAD

(72)Name of Inventor :
1)THALTIRI, Vikranth
2)CHAVVA, Kurumurthy
3)PANDA, Pradeepta Kumar

(57) Abstract :

The present invention describes a simple and efficient process for the synthesis novel nitrated pyrrole based high energy density materials (HEDMs) of Formula III-VI and is scalable. The process involves the use of simple and commercially readily available cheap reagents in good yields. The process comprises synthesizing nitrated pyrroles in four steps to obtain the new energetic compounds. Nitrated pyrrole salts (Formula III) are prepared by treating the nitrated pyrroles with appropriate base. The N-amino nitrated pyrroles (Formula IV) are synthesized by treating the above salts with common aminating agents. These N-amino compounds is converted to the corresponding nitramines (Formula V) by treating with a nitrating agent and subsequently, converted to stable energetic salts (Formula VI) upon treatment with corresponding sulfate or chloride salts of desired cations.

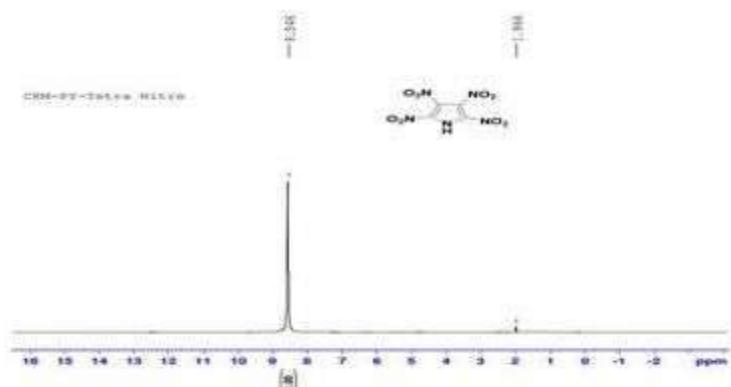

Figure 1: ^1H NMR spectrum of 2,3,4,5-tetranitropyrrole (II) in acetonitrile- d_3 .

No. of Pages : 44 No. of Claims : 15

(12) PATENT APPLICATION PUBLICATION

(21) Application No.201911050239 A

(19) INDIA

(22) Date of filing of Application :05/12/2019

(43) Publication Date : 11/06/2021

(54) Title of the invention : ASSEMBLAGE MERRIMENT APPARATUS AND METHOD OF OPERATION THEREOF

(51) International classification	:A63F0003000000, G06F0016335000, G06T0011600000, G06F0013400000, G06F0021330000	(71) Name of Applicant : 1)EDGAMES SERVICES PRIVATE LIMITED Address of Applicant :108, Dream Building, Technology Business Incubator, University of Delhi, New Delhi-110007, India Delhi India
(31) Priority Document No	:NA	(72) Name of Inventor :
(32) Priority Date	:NA	1)ANAND, Atul
(33) Name of priority country	:NA	
(86) International Application No	:NA	
Filing Date	:NA	
(87) International Publication No	: NA	
(61) Patent of Addition to Application Number:	NA	
Filing Date	:NA	
(62) Divisional to Application Number	:NA	
Filing Date	:NA	

(57) Abstract :

The present invention discloses a standalone educational merriment apparatus that is easily operated by beginners, young children and adolescents, and is cost effective. The assemblage merriment apparatus comprises a spinner device, a hardboard, plurality of tokens, plurality of items, plurality of cards, and plurality of movable devices. The plurality of tokens is used to transact the plurality of items, which helps in inculcating users about assemblage. The present invention also discloses a method of operation of the assemblage merriment apparatus.

No. of Pages : 8 No. of Claims : 5

(54) Title of the invention : NOVEL COMPOUND 1,2,4,4-TETRANITROPYRAZOLIDINE-3,5-DIONE (ACRAJONE) AND PROCESS FOR ITS SYNTHESIS

(51) International classification	:C07F0017020000, G01N0033574000, C07K0016100000, G01N0009240000, C08B0037000000	(71)Name of Applicant : 1)CHAIRMAN, DEFENCE RESEARCH & DEVELOPMENT ORGANISATION Address of Applicant :Ministry Of Defence, Govt. Of India, Room No 348, B-Wing, DRDO Bhawan, Rajaji Marg, New Delhi 110011, India Delhi India 2)ACRHEM, HYDERABAD
(31) Priority Document No	:NA	(72)Name of Inventor :
(32) Priority Date	:NA	1)KOORELLA, Rajasekhar
(33) Name of priority country	:NA	2)NAYUDU, Raatalu
(86) International Application No	:NA	3)GUGULOTHU, Ramkoti
Filing Date	:NA	
(87) International Publication No	: NA	
(61) Patent of Addition to Application Number	:NA	
Filing Date	:NA	
(62) Divisional to Application Number	:NA	
Filing Date	:NA	

(57) Abstract :

The present invention relates to novel high energy density material 1,2,4,4-tetranitropyrazolidine-3,5-dione and process for synthesis of novel high energy material 1,2,4,4-tetranitropyrazolidine-3,5-dione. More particularly, the present invention discloses the characterisation and synthesis of novel High energy density material 1,2,4,4-tetranitropyrazolidine-3,5-dione which has been acronym as (ACRAJONE).

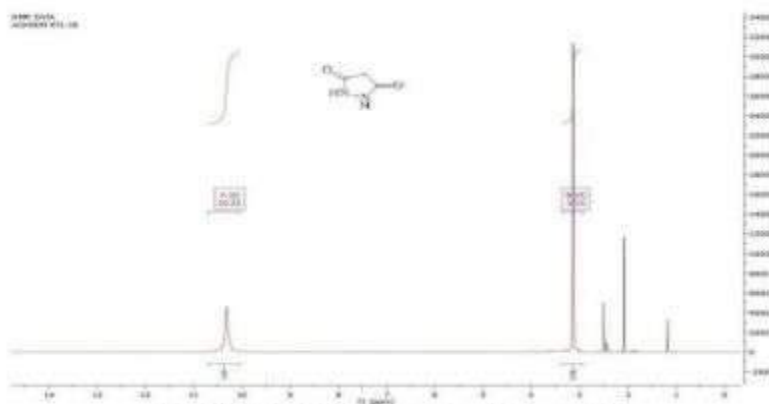

Fig. 1. ¹H NMR (DMSO-D₆) Spectrum of Compound III

No. of Pages : 26 No. of Claims : 5

(12) PATENT APPLICATION PUBLICATION

(21) Application No.201911050241 A

(19) INDIA

(22) Date of filing of Application :05/12/2019

(43) Publication Date : 11/06/2021

(54) Title of the invention : MARBLE MERRIMENT APPARATUS AND METHOD OF OPERATION THEREOF

(51) International classification	:H04L0029060000, H04N0021472000, G06F0016780000, G06F0003038000, H04W0072000000	(71) Name of Applicant : 1)EDGAMES SERVICES PRIVATE LIMITED Address of Applicant :108, Dream Building, Technology Business Incubator, University of Delhi, New Delhi-110007, India Delhi India
(31) Priority Document No	:NA	(72) Name of Inventor :
(32) Priority Date	:NA	1)ANAND, Atul
(33) Name of priority country	:NA	
(86) International Application No	:NA	
Filing Date	:NA	
(87) International Publication No	: NA	
(61) Patent of Addition to Application Number	:NA	
Filing Date	:NA	
(62) Divisional to Application Number	:NA	
Filing Date	:NA	

(57) Abstract :

The present invention discloses a standalone marble merriment apparatus that is easily operated by users without intervention and easily operated by beginners and young children. The merriment apparatus that comprises a spinning handboard with a pointer capable of being rotated in clockwise or anti-clockwise manner by the user. The handboard indicates available action conditions. A tray that is sectioned to receive triggering cards and objects. The user initiates the spinning of the pointer in either clockwise or anti-clockwise direction on reaching a stoppage an action condition pointed by the pointer and indicated on the handboard is engaged and the indicated objects are collected by the user. A comparison of the collected objects is done with the triggering card. Meeting the triggering card condition the collected objects from the users tray are returned and the card is acquired by the user.

No. of Pages : 9 No. of Claims : 7

(12) PATENT APPLICATION PUBLICATION

(21) Application No.201911050242 A

(19) INDIA

(22) Date of filing of Application :05/12/2019

(43) Publication Date : 11/06/2021

(54) Title of the invention : EXTRACTION MERRIMENT APPARATUS AND METHOD OF OPERATION THEREOF

(51) International classification	:A63F0003000000, A63F0011000000, G09F0005040000, A63F0001040000, A47F0005100000	(71) Name of Applicant : 1)EDGAMES SERVICES PRIVATE LIMITED Address of Applicant :108, Dream Building, Technology Business Incubator, University of Delhi, New Delhi-110007, India Delhi India
(31) Priority Document No	:NA	(72) Name of Inventor :
(32) Priority Date	:NA	1)ANAND, Atul
(33) Name of priority country	:NA	
(86) International Application No	:NA	
Filing Date	:NA	
(87) International Publication No	: NA	
(61) Patent of Addition to Application Number:	NA	
Filing Date	:NA	
(62) Divisional to Application Number	:NA	
Filing Date	:NA	

(57) Abstract :

An extraction merriment apparatus as per the present invention comprises a spinner, a plurality of boards, a plurality of cards, a plurality of blocking element, and a plurality of pattern-shaped elements. The extraction merriment apparatus is operated by selecting a board out of the plurality of design boards and further, choosing and distribution of five cards from the plurality of cards, depending on the level, to each user. The spinning of the spinner makes the spinner point towards a particular shape from a plurality of shapes displayed on the spinning device. Further, identification of a similar pattern to extract thereof, and blocking the same to indicate the extracted shape. The same helps in reproducing the pattern on the cards of the users.

No. of Pages : 8 No. of Claims : 5

(12) PATENT APPLICATION PUBLICATION

(21) Application No.201911050245 A

(19) INDIA

(22) Date of filing of Application :05/12/2019

(43) Publication Date : 11/06/2021

(54) Title of the invention : COLLATION MERRIMENT APPARATUS AND METHOD OF OPERATION THEREOF

(51) International classification	:G07F0017320000, G06K0009460000, F21V0023060000, G06K0009480000, A63F0001040000	(71) Name of Applicant : 1)EDGAMES SERVICES PRIVATE LIMITED Address of Applicant :108, Dream Building, Technology Business Incubator, University of Delhi, New Delhi- 110007, India Delhi India
(31) Priority Document No	:NA	(72) Name of Inventor :
(32) Priority Date	:NA	1)ANAND, Atul
(33) Name of priority country	:NA	
(86) International Application No	:NA	
Filing Date	:NA	
(87) International Publication No	: NA	
(61) Patent of Addition to Application Number:	NA	
Filing Date	:NA	
(62) Divisional to Application Number	:NA	
Filing Date	:NA	

(57) Abstract :

The present invention discloses a standalone educational merriment apparatus that is easily operated by beginners, young children and adolescents, and is cost effective. The assemblage merriment apparatus comprises a spinner device mounted on a hardboard, plurality of skill cards, a plurality of pattern blocks or connectors and a grid or frame. The said plurality of skill cards are randomly distributed to the user to collate the pattern blocks or connectors on a grid or frame accordingly. The present invention also discloses a method of operation of the assemblage merriment apparatus.

No. of Pages : 7 No. of Claims : 5

(54) Title of the invention : DEVICE FOR HOLDING A PASSENGER SEAT WITH VEHICLEBODY IN A VEHICLE

<p>(51) International classification</p> <p>(31) Priority Document No</p> <p>(32) Priority Date</p> <p>(33) Name of priority country</p> <p>(86) International Application No</p> <p style="padding-left: 20px;">Filing Date</p> <p>(87) International Publication No</p> <p>(61) Patent of Addition to Application Number</p> <p style="padding-left: 20px;">Filing Date</p> <p>(62) Divisional to Application Number</p> <p style="padding-left: 20px;">Filing Date</p>	<p>:B60N0002360000, H01M0002100000, B64D0011060000, B60K0001040000, G06F0001180000</p> <p>:NA</p> <p>:NA</p> <p>:NA</p> <p>:NA</p> <p>:NA</p> <p>:NA</p> <p>:NA</p> <p>:NA</p> <p>:NA</p> <p>:NA</p> <p>:NA</p> <p>:NA</p> <p>:NA</p>	<p>(71)Name of Applicant : 1)Daimler AG Address of Applicant :70546 Stuttgart Germany Germany</p> <p>(72)Name of Inventor : 1)Ms. Balendra Shobika 2)Mr. Balaji Pillai</p>
---	---	---

(57) Abstract :

A device for holding a passenger seat of a vehicle with a body 204 of the vehicle is disclosed, comprising a left side lock 200 and a right side lock located on the body 204 of the vehicle to hold a seat wire 206 coupled to a backrest of the seat for holding the seat with the body 204. Each of the left side lock 200 and the right side lock includes a clip 210 having a protrusion that engages with the seat wire 206; and a slotted box shaped structure 214 around the clip 210. The slotted box shaped structure 214 comprises a rear wall 216 located opposite to the clip 210 with a space there between to accommodate the seat wire 206, and having projections 218 to support the seat wire 206, and a side wall 220 to provide additional support to the seat wire 206.

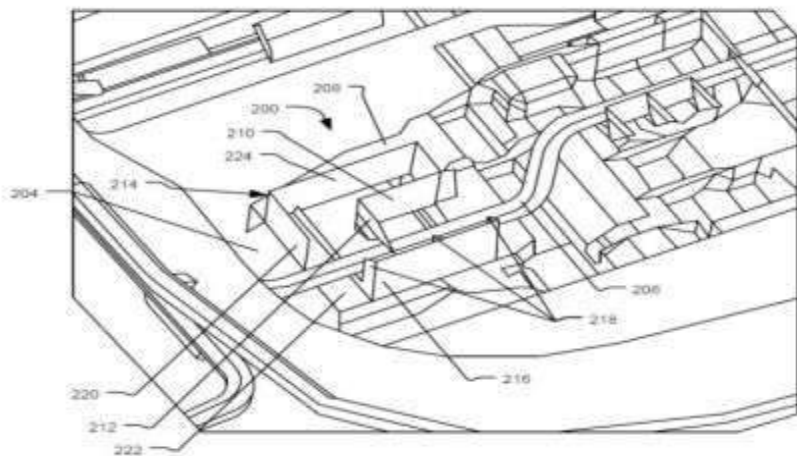

No. of Pages : 13 No. of Claims : 4

(54) Title of the invention : ANTI-ROTATION DEVICE FOR EXHAUST TAIL PIPES USED IN VEHICLES

<p>(51) International classification</p> <p>(31) Priority Document No</p> <p>(32) Priority Date</p> <p>(33) Name of priority country</p> <p>(86) International Application No</p> <p style="padding-left: 20px;">Filing Date</p> <p>(87) International Publication No</p> <p>(61) Patent of Addition to Application Number:</p> <p style="padding-left: 20px;">Filing Date</p> <p>(62) Divisional to Application Number</p> <p style="padding-left: 20px;">Filing Date</p>	<p>:F01N0013080000, F23R0003420000, E21B0007060000, F23C0015000000, F02D0041020000</p> <p>:NA</p> <p>:NA</p> <p>:NA</p> <p>:NA</p> <p>:NA</p> <p>: NA</p> <p>:NA</p> <p>:NA</p> <p>:NA</p> <p>:NA</p> <p>:NA</p> <p>:NA</p>	<p>(71)Name of Applicant : 1)Daimler AG Address of Applicant :70546 Stuttgart Germany Germany</p> <p>(72)Name of Inventor : 1)Mr. Karthik M P 2)Mr. Dinesh Babu</p>
--	---	--

(57) Abstract :

An anti-rotation device 100 for restricting rotational movement of a tail pipe 150 in vehicles is disclosed, having a first bracket 110 with a first end 112 fixed to an after-treatment system 140 and a second end 114 fixed to a first end 122 of a second bracket 120. The second bracket 120 has a C-shaped second end 124, which in combination with a C-clamp 130 envelops periphery of the tail pipe 150. The C-shaped second end 124 includes an aperture 126, which engages with an embossing 152 on periphery of the tail pipe 150 to orient the tail pipe 150 in a desired orientation and arrest rotation of the tail pipe 150.

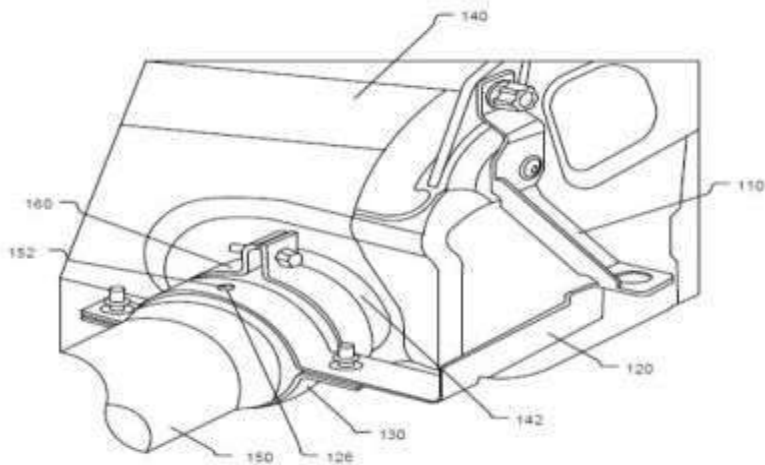

No. of Pages : 15 No. of Claims : 6

(54) Title of the invention : METHOD AND SYSTEM FOR IMAGE-PROCESSING FOR ENHANCING IMAGE

<p>(51) International classification</p> <p>(31) Priority Document No</p> <p>(32) Priority Date</p> <p>(33) Name of priority country</p> <p>(86) International Application No</p> <p style="padding-left: 20px;">Filing Date</p> <p>(87) International Publication No</p> <p>(61) Patent of Addition to Application Number</p> <p style="padding-left: 20px;">Filing Date</p> <p>(62) Divisional to Application Number</p> <p style="padding-left: 20px;">Filing Date</p>	<p>:A61B0006000000, H04N0021485000, G06F0021360000, G06F0016580000, H04W0072080000</p> <p>:NA</p> <p>:NA</p> <p>:NA</p> <p>:NA</p> <p>:NA</p> <p>:NA</p> <p>:NA</p> <p>:NA</p> <p>:NA</p> <p>:NA</p> <p>:NA</p> <p>:NA</p> <p>:NA</p> <p>:NA</p> <p>:NA</p>	<p>(71)Name of Applicant : 1)Samsung Electronics Co., Ltd. Address of Applicant :416 Maetan-Dong, Yeongtong-GU, Suwon-SI, Gyeonggi-do 442-742, Republic of Korea Republic of Korea</p> <p>(72)Name of Inventor : 1)PANDITA, Ishan 2)SHUKLA, Vishwajeet 3)SINGOUR, Mayank</p>
---	---	---

(57) Abstract :

The present subject matter refers an image-processing method and system (200) for enhancing image. The method comprises generating an up-sampled image from a first image captured by a first device. Using a classification logic, at least one device configuration corresponding to the first device is obtained based on the first image. The device configuration is based on one or more standard features derived from the set of images corresponding to different device configurations. Further, the method comprises generating by an image generator one or more second image(s) specific to one or more second device(s) based on said up-sampled image and the obtained device configuration from said classification logic. The one or more second image correspond to high end images.

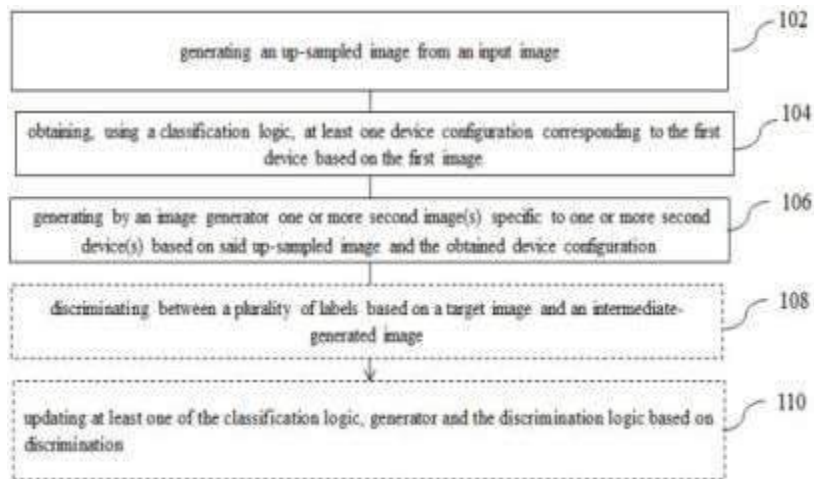

No. of Pages : 33 No. of Claims : 10

(54) Title of the invention : VEGAN HONEY PRODUCTION DEVICE AND TRACING SYSTEM THEREFOR

(51) International classification	:G06F0011360000, A23C0020020000, H04N0021234700, A61K0035644000, A23L0021250000	(71) Name of Applicant : 1)Acharya Balkrishna Address of Applicant :Divya Yog Mandir Trust, Kankhal, Haridwar- 249408, Uttarakhand, India. Uttarakhand India
(31) Priority Document No	:NA	(72) Name of Inventor : 1)Acharya Balkrishna
(32) Priority Date	:NA	
(33) Name of priority country	:NA	
(86) International Application No	:NA	
Filing Date	:NA	
(87) International Publication No	: NA	
(61) Patent of Addition to Application Number:	NA	
Filing Date	:NA	
(62) Divisional to Application Number	:NA	
Filing Date	:NA	

(57) Abstract :

A vegan honey production device and tracing system therefor. The device comprises a bottom box 1 for fixing the beehive structure to the lower side. At least a brood frame 2 is disposed in the brood chamber / bottom box 1 for keeping bee, eggs, larvae, capped and pupa. A queen net 3 is placed above the brood chamber 1 such that to enable labour / worker bees to enter in a wooden tray 4, provided to accommodate brood frames therein. A wooden cover 5 is provided to cover the wooden tray 4 and a lid 6 is provided over the wooden cover 5 such that to maintain darkness and warmth to the wooden cover. Also a honey traceable system is provided to trace the origin and genuineness of the honey. (Fig. 1)

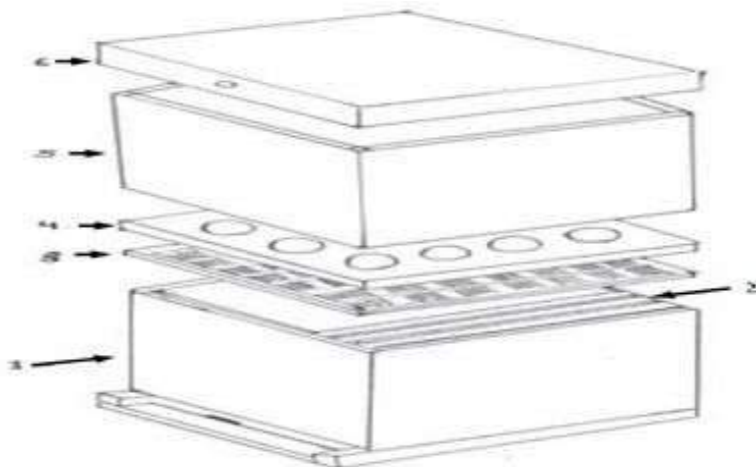

No. of Pages : 0 No. of Claims : 0

(54) Title of the invention : GRASS BASED STRAW

(51) International classification :B33Y0080000000,
B08B0009043000,
B08B0009000000,
B01J0020300000,
A61L0031140000

(31) Priority Document No :NA
(32) Priority Date :NA
(33) Name of priority country :NA
(86) International Application No :NA
Filing Date :NA
(87) International Publication No : NA
(61) Patent of Addition to Application Number :NA
Filing Date :NA
(62) Divisional to Application Number :NA
Filing Date :NA

(71)Name of Applicant :
1)Rishabh Pratap Singh
Address of Applicant :Village Nagla Udi, Post Shakrauli,
Distt- Etah, Uttar Pradesh Uttar Pradesh India

(72)Name of Inventor :
1)Rishabh Pratap Singh

(57) Abstract :

The present disclosure relates to a method of manufacturing of a straw from a grass material, the method comprising: cleaning a raw grass base material; shaping the cleaned grass based material; inserting an iron rod inside of the to make a hollow tubular structure; cleaning the shaped grass based material; and washing the hollow tubular structure to produce the straw.



No. of Pages : 18 No. of Claims : 7

(12) PATENT APPLICATION PUBLICATION

(21) Application No.201911050338 A

(19) INDIA

(22) Date of filing of Application :06/12/2019

(43) Publication Date : 11/06/2021

(54) Title of the invention : COMPRESSION TESTING EQUIPMENT FOR CONICAL COIL TYPE OPEN HELICAL SPRING FITTED WITH BASE PLATE AND CONE AT TOP

(51) International classification	:F16F0001080000, F16F0001020000, H01L0021683000, B21F0003020000, E01F0009688000	(71) Name of Applicant : 1)ORDNANCE PARACHUTE FACTORY Address of Applicant :NAPIER ROAD, CANTT. KANPUR UTTAR PRADESH-208004, INDIA Uttar Pradesh India
(31) Priority Document No	:NA	(72) Name of Inventor :
(32) Priority Date	:NA	1)ANKUR SINGH CHAUHAN
(33) Name of priority country	:NA	2)S. KONDAIYA
(86) International Application No	:NA	3)SHIVE CHANDRA
Filing Date	:NA	
(87) International Publication No	: NA	
(61) Patent of Addition to Application Number	:NA	
Filing Date	:NA	
(62) Divisional to Application Number	:NA	
Filing Date	:NA	

(57) Abstract :

Most of the springs commercially available are having coils of equal diameter open at bottoms & top and commercially available spring testing machines are suitable for testing these springs but the coil springs that are used in Brake Parachutes of Fighter Aircraft such as SU-30, MIG 21, LCA etc. have a conical shape i.e. the diameter of coil from base to top decreases giving it a conical shape and this special feature which make it different from other conical spring is that it is fitted with Base Plate and Cone at the top. That's why these springs are required to be compressed in special attachment from outside. Present innovation compresses these type of spring as per requirement from outside and also it have provision to keep spring at centre of equipment without deflecting it from centre position. The spring can be kept compressed in this position for required specified time. The present innovation meets all the requirement of specification of spring and is robust to enable testing of springs in large quantities without causing any damage to springs.

No. of Pages : 11 No. of Claims : 8

(12) PATENT APPLICATION PUBLICATION

(21) Application No.201911050374 A

(19) INDIA

(22) Date of filing of Application :06/12/2019

(43) Publication Date : 11/06/2021

(54) Title of the invention : COLLECTION MERRIMENT APPARATUS AND METHOD OF OPERATION THEREOF

(51) International classification	:A63B0071060000, G06F0003048400, G06K0009480000, A63B0021060000, A63B0026000000	(71) Name of Applicant : 1)EDGAMES SERVICES PRIVATE LIMITED Address of Applicant :108, Dream Building, Technology Business Incubator, University of Delhi, New Delhi- 110007, India Delhi India
(31) Priority Document No	:NA	(72) Name of Inventor :
(32) Priority Date	:NA	1)ANAND, Atul
(33) Name of priority country	:NA	
(86) International Application No	:NA	
Filing Date	:NA	
(87) International Publication No	: NA	
(61) Patent of Addition to Application Number	:NA	
Filing Date	:NA	
(62) Divisional to Application Number	:NA	
Filing Date	:NA	

(57) Abstract :

A collection merriment apparatus as per the present invention comprises a rolling device, a hardboard having patterns or shapes therein, and objects having the various shapes corresponding the shapes on the hardboard. The said apparatus operates by selection of a hardboard from a plurality of hardboards based on the level of difficulty, which proceed a user to choose a particular color counter from a plurality of counters, which forwardly enables a user to take turn to roll the rolling device one by one. Further, the rolling device would finalize the movement of the counter on the hardboard according to the points appearing on the rolling device. This enables the user to collect the shape corresponding to the object of the box on which the counter lands according to the points appearing on the rolling device and accumulate scores accordingly.

No. of Pages : 8 No. of Claims : 4

(12) PATENT APPLICATION PUBLICATION

(21) Application No.201911050375 A

(19) INDIA

(22) Date of filing of Application :06/12/2019

(43) Publication Date : 11/06/2021

(54) Title of the invention : SYMMETRY MERRIMENT APPARATUS AND METHOD OF OPERATION THEREOF

(51) International classification	:H02J0003380000, B41M0001120000, G06F0017500000, H02M0005400000, G06F0003048800	(71) Name of Applicant : 1)EDGAMES SERVICES PRIVATE LIMITED Address of Applicant :108, Dream Building, Technology Business Incubator, University of Delhi, New Delhi-110007, India Delhi India
(31) Priority Document No	:NA	(72) Name of Inventor :
(32) Priority Date	:NA	1)ANAND, Atul
(33) Name of priority country	:NA	
(86) International Application No	:NA	
Filing Date	:NA	
(87) International Publication No	: NA	
(61) Patent of Addition to Application Number	:NA	
Filing Date	:NA	
(62) Divisional to Application Number	:NA	
Filing Date	:NA	

(57) Abstract :

The present invention discloses a symmetry merriment apparatus having a design board with an incomplete image on which a stencil is aligned. The stencil is adopted to have a grid that is capable of receiving a number of symmetrical components. The symmetrical components are fixed in the placed location by the grid and guides the users so as to complete the image of the design board.

No. of Pages : 6 No. of Claims : 5

(12) PATENT APPLICATION PUBLICATION

(21) Application No.201911050377 A

(19) INDIA

(22) Date of filing of Application :06/12/2019

(43) Publication Date : 11/06/2021

(54) Title of the invention : PREDICTION MERRIMENT APPARATUS AND METHOD OF OPERATION THEREOF

(51) International classification	:G06F0012086400, A63F0009180000, G07F0007020000, G09F0005040000, A63F0011000000	(71) Name of Applicant : 1)EDGAMES SERVICES PRIVATE LIMITED Address of Applicant :108, Dream Building, Technology Business Incubator, University of Delhi, New Delhi-110007, India Delhi India
(31) Priority Document No	:NA	(72) Name of Inventor :
(32) Priority Date	:NA	1)ANAND, Atul
(33) Name of priority country	:NA	
(86) International Application No	:NA	
Filing Date	:NA	
(87) International Publication No	: NA	
(61) Patent of Addition to Application Number:	NA	
Filing Date	:NA	
(62) Divisional to Application Number	:NA	
Filing Date	:NA	

(57) Abstract :

A prediction merriment apparatus as per the present invention comprises a spinner, a hardboard, a plurality of cards, plurality of charts, and plurality of items. The said merriment apparatus operates by picking of a card from plurality of cards, displaying numbers according to which the number of items are to be placed on the hardboard. Further, spinning of the spinner displays numbers, which additionally adds or remove the number of items. The apparatus drives by the way of a prediction by the users, of the numbers that would remain after completion of a pre-determined number of rounds, cycles or iterations, based on the number of items initially placed on the board.

No. of Pages : 7 No. of Claims : 4

(54) Title of the invention : ARRANGEMENT MERRIMENT APPARATUS AND METHOD OF OPERATION THEREOF

(51) International classification :A63F0003000000,
A63F0009060000,
A63F0003040000,
A63F0011000000,
G06K0007000000

(31) Priority Document No :NA
(32) Priority Date :NA
(33) Name of priority country :NA
(86) International Application No :NA
Filing Date :NA
(87) International Publication No : NA
(61) Patent of Addition to Application Number:NA
Filing Date :NA
(62) Divisional to Application Number :NA
Filing Date :NA

(71)**Name of Applicant :**
1)EDGAMES SERVICES PRIVATE LIMITED
Address of Applicant :108,Dream Building, Technology
Business Incubator, University of Delhi Delhi India

(72)**Name of Inventor :**
1)ANAND, Atul

(57) Abstract :

The present invention discloses a standalone educational merriment apparatus that is easily operated by beginners, young children and adolescents, and is cost effective. The arrangement merriment apparatus comprises a pointer device, plurality of spinner devices, plurality of frames, plurality of objects or pieces and plurality of cards. The plurality of objects is arranged on the plurality of frames as per patterns embossed on the plurality of cards. The present invention also discloses a method of operation of the arrangement merriment apparatus.

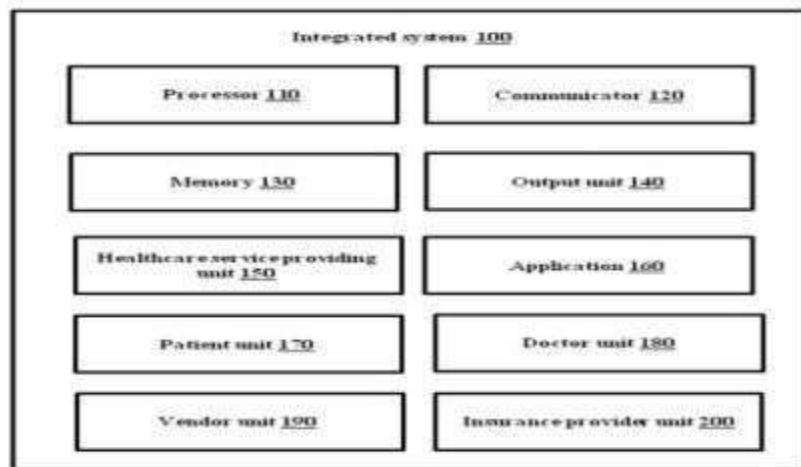

No. of Pages : 9 No. of Claims : 5

(12) PATENT APPLICATION PUBLICATION

(21) Application No.201911050386 A

(19) INDIA

(22) Date of filing of Application :06/12/2019

(43) Publication Date : 11/06/2021

(54) Title of the invention : BRIDGING MERRIMENT APPARATUS AND METHOD OF OPERATION THEREOF

(51) International classification	:H04L0012180000, G01D0013220000, A61B0005055000, G01C0009120000, H04W0004180000	(71) Name of Applicant : 1)EDGAMES SERVICES PRIVATE LIMITED Address of Applicant :108, Dream Building, Technology Business Incubator, University of Delhi, New Delhi-110007, India Delhi India
(31) Priority Document No	:NA	(72) Name of Inventor :
(32) Priority Date	:NA	1)ANAND, Atul
(33) Name of priority country	:NA	
(86) International Application No	:NA	
Filing Date	:NA	
(87) International Publication No	: NA	
(61) Patent of Addition to Application Number	:NA	
Filing Date	:NA	
(62) Divisional to Application Number	:NA	
Filing Date	:NA	

(57) Abstract :

The present invention provides a bridging merriment apparatus that has a handboard with number of sections indicating bridging mechanism. A pointer mounted on the handboard that is capable of rotating in a clockwise or anti-clockwise direction. A trigger board indicating and also capable of receiving bridging mechanisms. A user initiates the rotation of the pointer on the handboard. On resting the pointer points to the available bridging mechanism that may be received by the trigger board. The applicable bridging mechanisms are connected on the trigger board until all the connections are satisfied.

No. of Pages : 7 No. of Claims : 4

(54) Title of the invention : APPARATUS FOR SPREADING AN AGRICULTURAL MATERIAL

(51) International classification :B32B0038000000,
A45F0005000000,
A01C0003060000,
F16F0001160000,
B02C0013282000

(31) Priority Document No :NA
(32) Priority Date :NA
(33) Name of priority country :NA
(86) International Application No :NA
Filing Date :NA
(87) International Publication No : NA
(61) Patent of Addition to Application Number :NA
Filing Date :NA
(62) Divisional to Application Number :NA
Filing Date :NA

(71)**Name of Applicant :**
1)Chitkara Innovation Incubator Foundation
Address of Applicant :SCO: 160-161, Sector -9c, Madhya Marg, Chandigarh- 160009, India. Chandigarh India

(72)**Name of Inventor :**
1)KADYAN, Virender
2)KOUNDAL, Deepika

(57) Abstract :

According to an embodiment, the present disclosure provides an apparatus for spreading an agricultural material. The apparatus for spreading an agricultural material can include a support structure, a housing having a storage space to store the material, the housing can include an inlet opening to receive the material, and an outlet opening for outflow of the material from the housing, the housing fitted on the support structure such that a gap is created between the support structure and an outlet opening of the housing to allow outflow of the material, a slider plate slidably configured with the outlet opening of the housing. A rotor fitted on the support structure, wherein the rotor is configured such that a rotary part of the rotor is located in the gap for spreading the material coming out from the outlet opening through the gap.

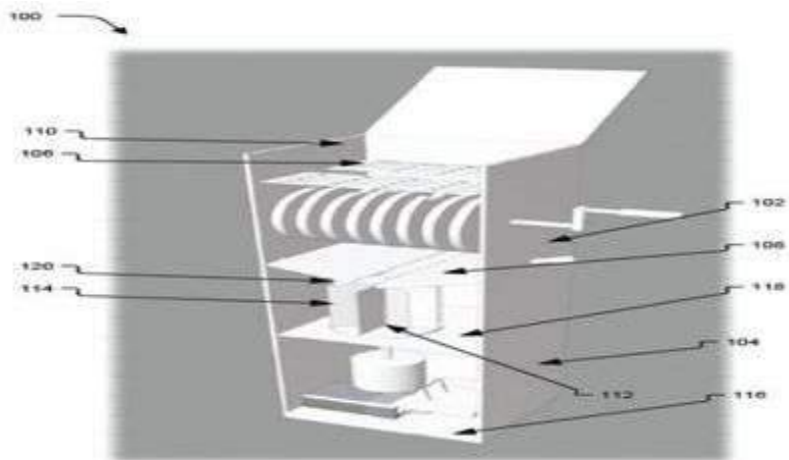

No. of Pages : 17 No. of Claims : 7

(12) PATENT APPLICATION PUBLICATION

(21) Application No.201911050469 A

(19) INDIA

(22) Date of filing of Application :06/12/2019

(43) Publication Date : 11/06/2021

(54) Title of the invention : PATTERNING MERRIMENT APPARATUS AND METHOD OF OPERATION THEREOF

(51) International classification	:H04M0017020000, A63F0003040000, H04N0021658000, G12B0011040000, B05B0001300000	(71) Name of Applicant : 1)EDGAMES SERVICES PRIVATE LIMITED Address of Applicant :108 Dream Building, Technology Business Incubator, University of Delhi Delhi India
(31) Priority Document No	:NA	(72) Name of Inventor :
(32) Priority Date	:NA	1)ANAND, Atul
(33) Name of priority country	:NA	
(86) International Application No	:NA	
Filing Date	:NA	
(87) International Publication No	: NA	
(61) Patent of Addition to Application Number	:NA	
Filing Date	:NA	
(62) Divisional to Application Number	:NA	
Filing Date	:NA	

(57) Abstract :

The present invention discloses a standalone educational merriment apparatus that is easily operated by beginners, young children and adolescents, and is cost effective. The patterning merriment apparatus comprises a pointer device, a spinner device, a hardboard, plurality of symbol devices and a booklet. The plurality of symbol devices is arranged on the hardboard as per patterns embossed on the booklet. The present invention also discloses a method of operation of the assemblage merriment apparatus.

No. of Pages : 8 No. of Claims : 4

(12) PATENT APPLICATION PUBLICATION

(21) Application No.201911050470 A

(19) INDIA

(22) Date of filing of Application :06/12/2019

(43) Publication Date : 11/06/2021

(54) Title of the invention : COMPILING MERRIMENT APPARATUS AND METHOD OF OPERATION THEREOF

(51) International classification	:G06F0003048400, G06F0003048200, A63F0011000000, A63F0001000000, A63F0003000000	(71) Name of Applicant : 1)EDGAMES SERVICES PRIVATE LIMITED Address of Applicant :108 Dream Building, Technology Business Incubator, University of Delhi New Delhi India Delhi India
(31) Priority Document No	:NA	(72) Name of Inventor :
(32) Priority Date	:NA	1)ANAND, Atul
(33) Name of priority country	:NA	
(86) International Application No	:NA	
Filing Date	:NA	
(87) International Publication No	: NA	
(61) Patent of Addition to Application Number:	NA	
Filing Date	:NA	
(62) Divisional to Application Number	:NA	
Filing Date	:NA	

(57) Abstract :

A compiling merriment apparatus as per the present invention comprises a spinner device on a hardboard, plurality of cards with various pictures thereon, plurality of connecting pieces for making the pictures depicted on the cards, plurality of non-standard measuring tools, and a hardboard base to place the cards. The said apparatus is operated by selecting a set or deck of cards depending on the level, which enables each user to have a single card each, which being enabled with a unique design, assists the user to assemble the same. Further, spinning of the spinner device displays number of connecting pieces to be collected.

No. of Pages : 7 No. of Claims : 4

(54) Title of the invention : METHOD AND SYSTEM FOR MANAGING POWER CONSUMPTION IN A FLEXIBLE DISPLAY DEVICE

(51) International classification :G06F0001160000,
G06F0003041000,
G06F0003010000,
G06F0003048700,
A61B0005155000

(31) Priority Document No :NA
(32) Priority Date :NA
(33) Name of priority country :NA
(86) International Application No :NA
Filing Date :NA
(87) International Publication No : NA
(61) Patent of Addition to Application Number:NA
Filing Date :NA
(62) Divisional to Application Number :NA
Filing Date :NA

(71)Name of Applicant :
1)Samsung Electronics Co., Ltd.
Address of Applicant :416 Maetan-Dong, Yeongtong-GU,
Suwon-SI, Gyeonggi-do 442-742, Republic of Korea
Korea

(72)Name of Inventor :
1)SHARMA, Ankur
2)GUPTA, Atul
3)GUPTA, Sachin Kumar

(57) Abstract :

A method (900) for managing power consumption in a flexible display device (104) is disclosed. The method (900) includes detecting bending of the flexible display device (104). The bending is indicative of an instruction to generate an auxiliary power. Further, the method (900) includes determining at least one value of a set of operational parameters associated with the bending of the flexible display device (104), based on the bending. The method (900) includes operating an alternate power source (112) to generate the auxiliary power to operate the flexible display device (104), based on the at least one value of the set of operational parameters. Further, the method (900) includes determining at least one application and at least one sub-function of the at least one application in the flexible display device (104) operable by using the auxiliary power.

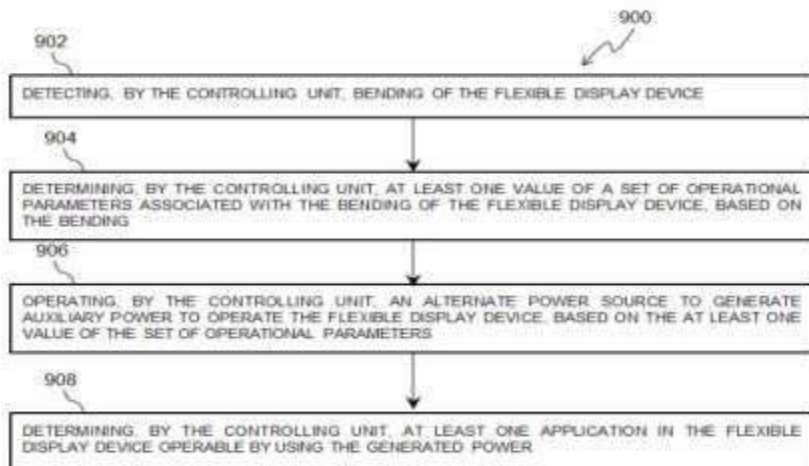

No. of Pages : 32 No. of Claims : 13

(54) Title of the invention : NON-REMOVABLE PULL OUT ISOFIX COVER

(51) International classification	:B60N0002280000, G01B0003100000, B64C0001060000, B04B0007020000, E06B0009326000	(71) Name of Applicant : 1)Daimler AG Address of Applicant :70546 Stuttgart Germany Germany
(31) Priority Document No	:NA	(72) Name of Inventor : 1)Ms. Renuka Munnale
(32) Priority Date	:NA	
(33) Name of priority country	:NA	
(86) International Application No	:NA	
Filing Date	:NA	
(87) International Publication No	: NA	
(61) Patent of Addition to Application Number	:NA	
Filing Date	:NA	
(62) Divisional to Application Number	:NA	
Filing Date	:NA	

(57) Abstract :

A non-removable pull out Isofix cover assembly 100 is disclosed having an upper cover 110 and a cover housing 130. The upper cover 110 has an elongate member 124 disposed along a back face on a top portion of the upper cover 110, and a pull slot disposed on a bottom portion. The elongate member 124 includes a retraction spring 122 and a lock 126. The cover housing 130 includes an axial bore that receives and retains the elongate member along with the retraction spring 122 and the lock 126, and allow the upper cover 110 to be pulled away from the cover housing 130 and rotated about an axis of the elongate member. Pulling and rotating the upper cover (110) exposes a child restraint-seat holder housed within the cover housing (130) for removably attaching a mating member of a child restraint-seat with the child restraint-seat holder.

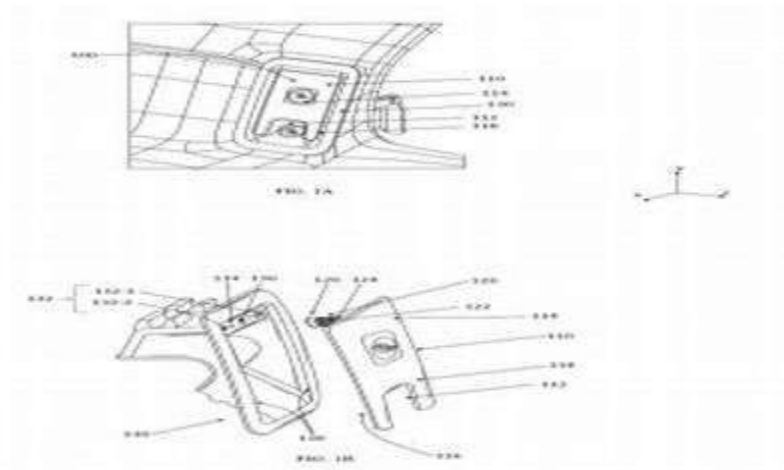

No. of Pages : 15 No. of Claims : 9

(54) Title of the invention : COOLING PLATE DESIGN FOR ENHANCED BATTERY PERFORMANCE IN ELECTRIC VEHICLES

(51) International classification	:H01M0010613000, H01M0010625000, H01M0010647000, H01M0002100000, H01M0010655600	(71) Name of Applicant : 1)Daimler AG Address of Applicant :70546, Stuttgart, Germany. Germany
(31) Priority Document No	:NA	(72) Name of Inventor : 1)Mr. Prithviraj Pochampalli
(32) Priority Date	:NA	
(33) Name of priority country	:NA	
(86) International Application No	:NA	
Filing Date	:NA	
(87) International Publication No	: NA	
(61) Patent of Addition to Application Number	:NA	
Filing Date	:NA	
(62) Divisional to Application Number	:NA	
Filing Date	:NA	

(57) Abstract :

A cooling plate assembly (100) for uniform cooling of battery module in electric vehicles is disclosed, having a bottom plate (110) in thermal contact with battery module, a middle plate (120) and a top plate (130) arranged in a stacked manner to create an onward passage (150) for flow of coolant between middle plate (120) and top plate (130), and a flow conduit (152) between bottom plate (110) and middle plate (120). An outlet (126) in fluidic communication with flow conduit (152) is coupled to middle plate (120) and is located coaxially within an inlet (136) coupled to top plate (130) in fluidic communication with onward passage (150). Inlet (136) and outlet (126) are located at center for the coolant to flow in centrosymmetric manner. Bleed-holes (129) are provided in high temperature zones to feed low temperature coolant directly to the high temperature zones to achieve uniform temperature. Flow guides (127) are provided to ensure uniform flow distribution in the flow conduit (152).

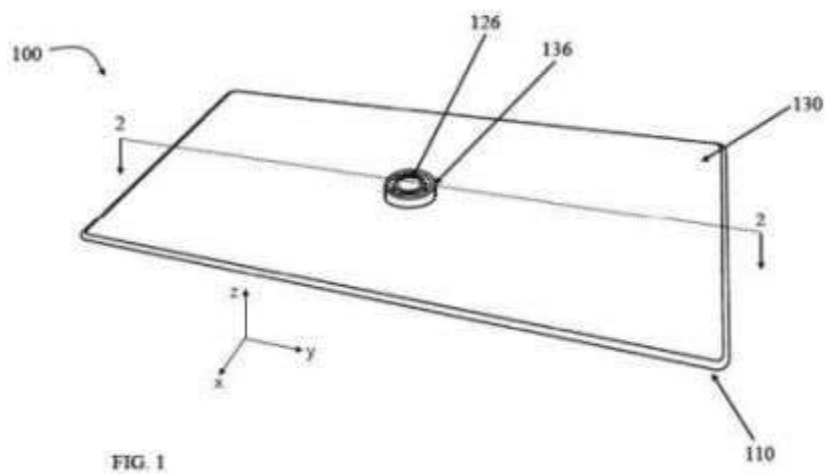

No. of Pages : 28 No. of Claims : 10

(54) Title of the invention : ROOF MOUNTED PROGRESSIVE AIRBAG SYSTEM

(51) International classification	:B60R0021231000, B60R0021000000, B60R0021214000, B60R0021207000, B60N0002427000	(71) Name of Applicant : 1)Daimler AG Address of Applicant :70546 Stuttgart Germany Germany
(31) Priority Document No	:NA	(72) Name of Inventor :
(32) Priority Date	:NA	1)Mr. Nikhil Chaudhari
(33) Name of priority country	:NA	2)Mr. Balaji Pillai
(86) International Application No	:NA	3)Mr. Dusmanta Pattanaik
Filing Date	:NA	4)Mr. Srikanth Shivalingaiah
(87) International Publication No	: NA	
(61) Patent of Addition to Application Number	:NA	
Filing Date	:NA	
(62) Divisional to Application Number	:NA	
Filing Date	:NA	

(57) Abstract :

An improved airbag system 100 for a vehicle is disclosed, comprising inflators 102 mounted to roof rails 104 of a roof 106 of the vehicle; a roof airbag 108 disposed between the roof 106 and a headliner 110, and an ejection mechanism 114. The ejection mechanism 114 is configured to eject the roof airbag 108 from the headliner 110 towards downward direction to enclose an upper portion of an occupant on a seat of the vehicle and a backrest of the seat. The inflators are configured to fill pressurized gas in the roof airbag 108 to inflate the roof airbag 108 in deployed condition to protect the occupant during collision. A seat airbag is arranged in the backrest of the seat, which inflates after inflation of the roof airbag 108 to tighten the roof airbag 108 to restrain forward movement of the occupant relative to the seat.

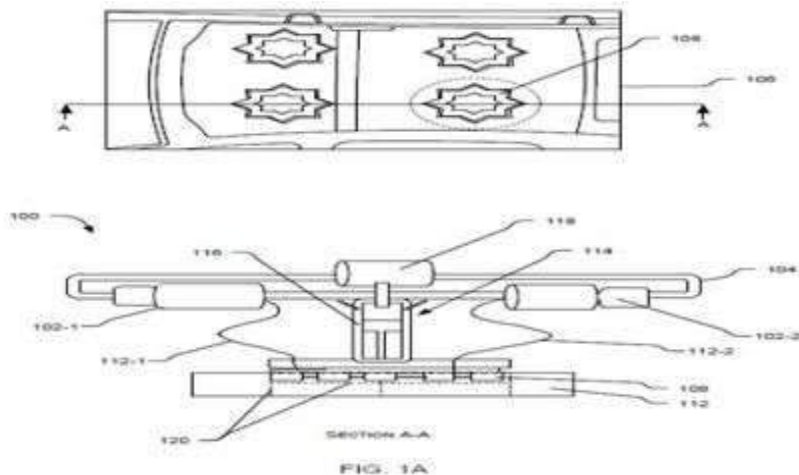

No. of Pages : 16 No. of Claims : 9

(12) PATENT APPLICATION PUBLICATION

(21) Application No.201911050530 A

(19) INDIA

(22) Date of filing of Application :06/12/2019

(43) Publication Date : 11/06/2021

(54) Title of the invention : PATH LOSS COMPENSATION IN MM WAVE 5G ANTENNA WITH 3D-PRINTED RADOME

(51) International classification	:G06F0001160000, H05K0005020000, E04B0001680000, B29C0065500000, H01Q0001240000	(71) Name of Applicant : 1)INDIAN INSTITUTE OF TECHNOLOGY DELHI Address of Applicant :Hauz Khas, New Delhi-110016 Delhi India
(31) Priority Document No	:NA	(72) Name of Inventor :
(32) Priority Date	:NA	1)Patrick Djan-Sampson
(33) Name of priority country	:NA	2)Enno Ubben
(86) International Application No	:NA	
Filing Date	:NA	
(87) International Publication No	: NA	
(61) Patent of Addition to Application Number:	:NA	
Filing Date	:NA	
(62) Divisional to Application Number	:NA	
Filing Date	:NA	

(57) Abstract :

An access point, comprising a first shell aligned along a horizontal plane for securing a first antenna and a second shell and a third shell placed at opposite ends of the first shell and oriented at 45 degree to the plane of the first shell for securing a second antenna and a third antenna, such that bottom sides of the second shell and the third shell face each other.

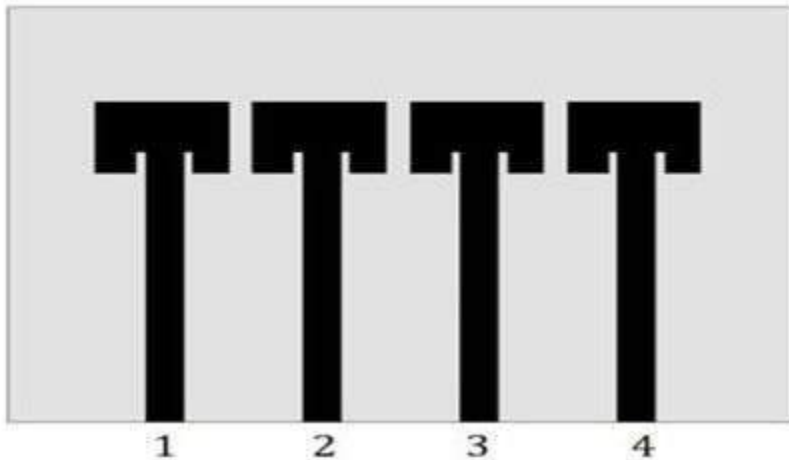

No. of Pages : 24 No. of Claims : 13

(54) Title of the invention : SAFETY DEVICE FOR VEHICLE ACCELERATOR

(51) International classification :B60K0026020000,
F02D0011100000,
B60K0028060000,
A63F0013211000,
B60W0010040000

(31) Priority Document No :NA
(32) Priority Date :NA
(33) Name of priority country :NA
(86) International Application No :NA
Filing Date :NA
(87) International Publication No : NA
(61) Patent of Addition to Application Number :NA
Filing Date :NA
(62) Divisional to Application Number :NA
Filing Date :NA

(71)Name of Applicant :
1)WU, Wen-Yi
Address of Applicant :No. 558-1, Sec. 1, Jieshou Rd., Sanxia
Dist., New Taipei City 237, TAIWAN

(72)Name of Inventor :
1)WU, Wen-Yi

(57) Abstract :

The safety device for vehicle accelerator includes a control member. The control member includes a microprocessor, a first variable resistor, and a buzzer. The control member is electrically connected to a vehicles engine controller and acceleration pedal detector. When the acceleration pedal is suddenly depressed, the acceleration pedal detector sends a signal to the control member to engage the buzzer. The control member then converts and transmits the signal to the engine controller so that the engine controller reduces fuel injection, slows the vehicle down. The control member then turns off the buzzer.

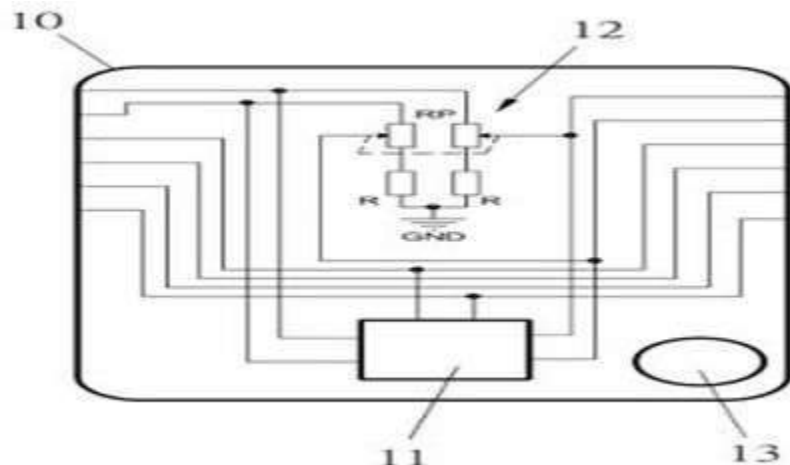

No. of Pages : 13 No. of Claims : 10

(54) Title of the invention : SYSTEM AND METHOD FOR VIDEO EDITING

(51) International classification	:G11B0027034000, G11B0027340000, H04N0021422000, G11B0027031000, G06F0021320000	(71) Name of Applicant : 1)Chandigarh University Address of Applicant :National Highway 95, Chandigarh- Ludhiana Highway, Mohali, Punjab - 140413, India. Punjab India
(31) Priority Document No	:NA	(72) Name of Inventor :
(32) Priority Date	:NA	1)Mayur Nair
(33) Name of priority country	:NA	2)Prabhjeet Kaur
(86) International Application No	:NA	3)Aman Singh
Filing Date	:NA	4)Raghav Vasudeva
(87) International Publication No	: NA	
(61) Patent of Addition to Application Number	:NA	
Filing Date	:NA	
(62) Divisional to Application Number	:NA	
Filing Date	:NA	

(57) Abstract :

The present invention relates to a system for video editing, comprising a camera 2 incorporated with the system for capturing of an image/video, wherein the image/video 5 is compressed 6 in a user interface 1, a cloud storage 3 for extracting 7 the compressed 6 image/video, the user interface 1 is used for rendering and compressing the extracted 7 image/video using a video time line 9, wherein upon rendering the user interface 1 downloads and compresses the image/video from the cloud storage unit 3. A method for video editing, comprising steps of capturing an image/video through a camera 2, feeding the image/video 5 in the user interface and uploading the compressed image/video in a cloud storage unit, extracting 7 the compressed image/video from the cloud storage unit, rendering and compressing of the extracted image/video by providing a time line, and downloading the compressed image/video from the cloud storage unit 3.

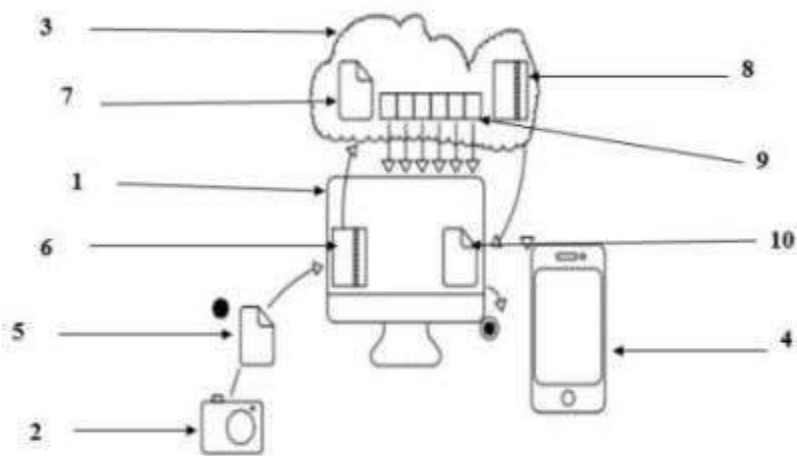

No. of Pages : 14 No. of Claims : 7

(54) Title of the invention : SMART WALLET

(51) International classification :G06Q0020320000,
G06Q0020360000,
A61L0009140000,
B60L0003000000,
G01R0031020000

(31) Priority Document No :NA
(32) Priority Date :NA
(33) Name of priority country :NA
(86) International Application No :NA
Filing Date :NA
(87) International Publication No : NA
(61) Patent of Addition to Application Number :NA
Filing Date :NA
(62) Divisional to Application Number :NA
Filing Date :NA

(71)**Name of Applicant :**
1)Chandigarh University
Address of Applicant :National Highway 95, Chandigarh-Ludhiana Highway, Mohali, Punjab - 140413, India. Punjab India

(72)**Name of Inventor :**
1)Vikas Latiyal
2)Aman Satya Dubey
3)Yogendra Narayan

(57) Abstract :

The present invention relates to a smart wallet, comprising of at least two sleeves with multiple of compartments for storing valuables like money, debit or credit card, a sensor installed in the wallet for detecting interaction of light during opening of the sleeves, a micro-controller installed in communication with the sensor to apprehend the signal and to generate a command signal, at least an illuminating unit interconnected with the micro-controller for getting activated upon receiving command signal from the micro-controller, a location determination unit coupled with a communication unit for sensing the location of the wallet and communicating the detected location to a user interface, a power supply unit installed in the wallet for providing electricity and a switch interlaced within the circuit for controlling the flow of electricity.

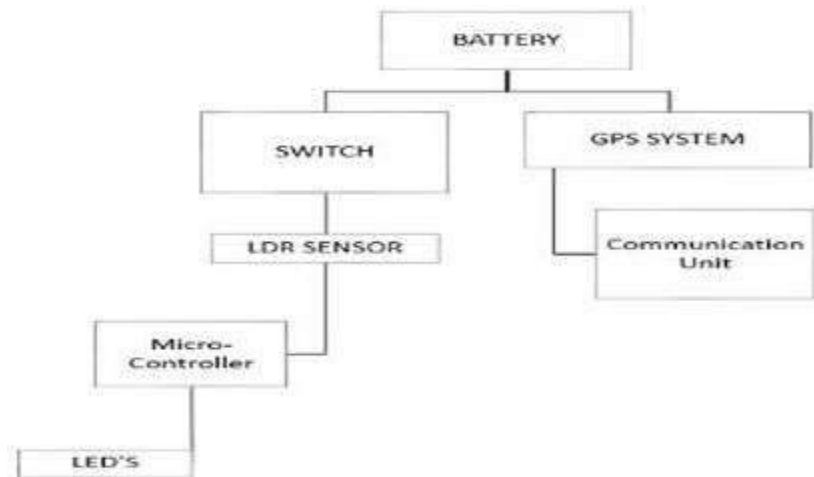

No. of Pages : 12 No. of Claims : 10

(54) Title of the invention : AUTOMOBILE ACCIDENT DETECTION SYSTEM

(51) International classification :G07C0005080000,
B60R0016023000,
G07C0005000000,
F02D0041280000,
B60R0021000000

(31) Priority Document No :NA
(32) Priority Date :NA
(33) Name of priority country :NA
(86) International Application No :NA
Filing Date :NA
(87) International Publication No : NA
(61) Patent of Addition to Application Number :NA
Filing Date :NA
(62) Divisional to Application Number :NA
Filing Date :NA

(71)**Name of Applicant :**
1)Chandigarh University
Address of Applicant :National Highway 95, Chandigarh-
Ludhiana Highway, Mohali, Punjab 140413, India. Punjab India

(72)**Name of Inventor :**
1)Harsh Goyal

(57) Abstract :

The present invention relates to an automobile detection system, comprising a sensor mounted on an on-board chip for generating a relative voltage signal upon sensing damping force at the time of an accident of the automobile, a digital meter scanner associated with the on-board chip for scanning details of a driver in order to unlock the automobile, a control unit interlinked with the sensor and digital meter for generating a command signal upon receiving the voltage signal from the sensor and the details of the driver and a communication unit installed in continuation with the control unit for receiving and transmitting the command signal to nearby medical centres and police stations for providing assistance to the driver during an accident.

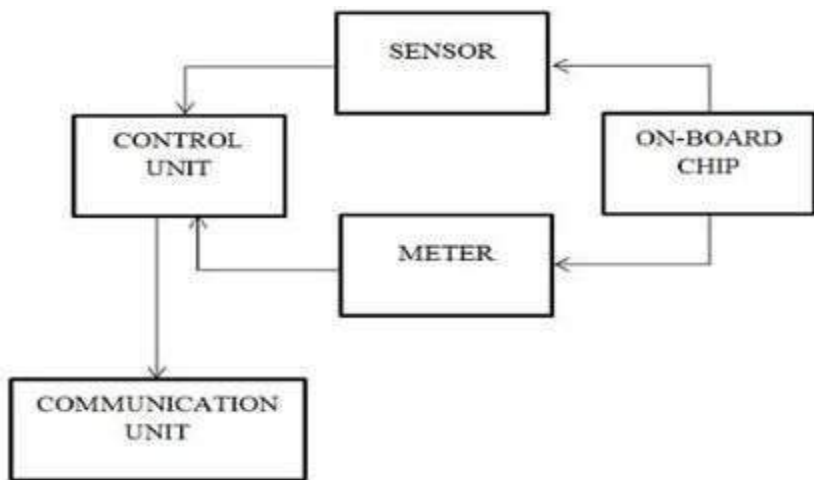

No. of Pages : 11 No. of Claims : 8

(54) Title of the invention : AIRFOIL DEVICE FOR VEHICLES

(51) International classification :B60H0001320000,
H02M0001380000,
B01J0029076000,
B64C0003140000,
F15D0001120000

(31) Priority Document No :NA
(32) Priority Date :NA
(33) Name of priority country :NA
(86) International Application No :NA
Filing Date :NA
(87) International Publication No : NA
(61) Patent of Addition to Application Number :NA
Filing Date :NA
(62) Divisional to Application Number :NA
Filing Date :NA

(71)**Name of Applicant :**
1)Chandigarh University
Address of Applicant :National Highway 95, Chandigarh-Ludhiana Highway, Mohali, Punjab - 140413, India. Punjab India

(72)**Name of Inventor :**
1)Aishwarya Dhara
2)Pon Maa Kishan A

(57) Abstract :

The present invention relates to an airfoil device for vehicle that is characterized by modified design comprising of, a first edge 1 and second edge 2 extended from a first point to second point lying on a chord, a first 4 and second 3 sidewall joined together at the first 1 and second 2 edges, the first edge 1 includes a stagnation region of the airfoil device having a first curvature substantially equal to zero within the stagnation region, the first curvature associated with the first sidewall 4 of the airfoil device extending from the first point to second point and a second curvature associated with the second sidewall 3 of the airfoil device extending from the first point to second point. The airfoil device reduces the drag about 25%-35% and providing efficient vertical lift for about 3% increment in thickness thus operating efficiently in a Mach number greater than 5.

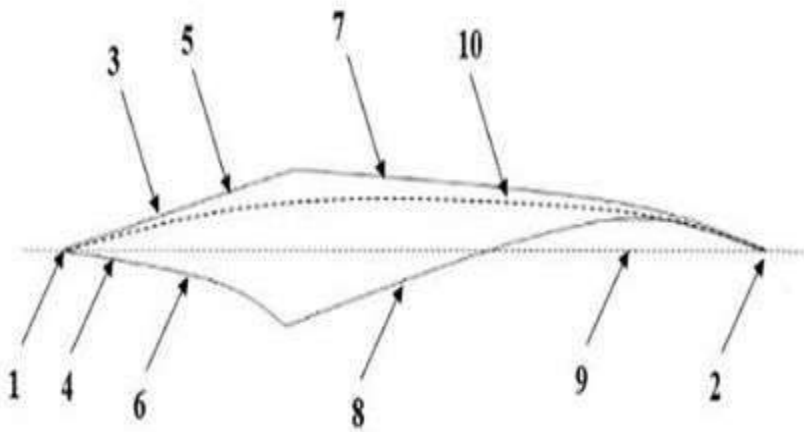

No. of Pages : 12 No. of Claims : 9

(54) Title of the invention : LOCAL SHOPPING SYSTEM

(51) International classification :G06Q0030060000,
G06Q0040000000,
F41G0007220000,
F41G0007000000,
G06Q0040020000

(31) Priority Document No :NA
(32) Priority Date :NA
(33) Name of priority country :NA
(86) International Application No :NA
Filing Date :NA
(87) International Publication No : NA
(61) Patent of Addition to Application Number :NA
Filing Date :NA
(62) Divisional to Application Number :NA
Filing Date :NA

(71)**Name of Applicant :**
1)Chandigarh University
Address of Applicant :National Highway 95, Chandigarh-Ludhiana Highway, Mohali, Punjab - 140413, India. Punjab India

(72)**Name of Inventor :**
1)Arjun Saibo

(57) Abstract :

The present invention relates to local shopping system, comprising a seller module installed in the system for enabling a seller to register and upload product information that he/she prefers to sell, a buyer module wirelessly linked to the seller module for visualizing product information in order to buy a product, a delivery module interlinked with the modules for providing a platform to work seekers that are registered on the delivery module and are selected for delivering purchased products from the seller to the buyer, a GPS connected to each of the modules for tracking location of the seller, buyer and work seekers and a control station interlinked with the modules and GPS that fetches the location of the seller, buyer and work seeker in order to allocate the delivery task to a work seeker who is present in the proximity of the seller and the buyer.

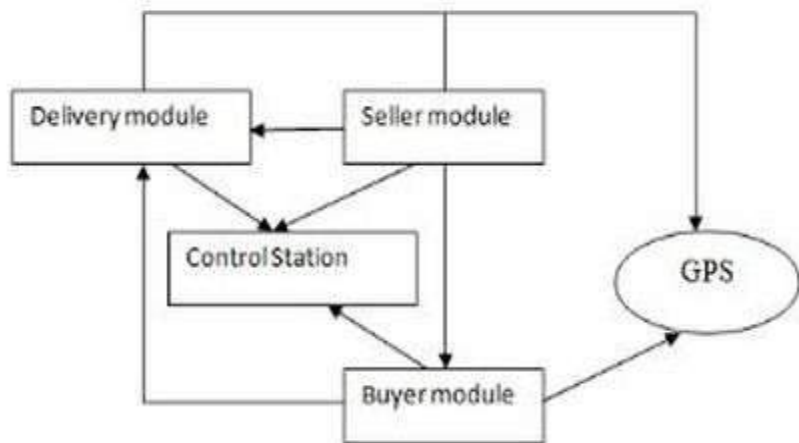

No. of Pages : 10 No. of Claims : 6

(54) Title of the invention : A TOOL AND A METHOD FOR GRIPPING VEHICLE STRUCTURAL MEMBERS

(51) International classification	:A45F0005000000, F16M0011140000, B60R0013020000, G09F0021040000, B25J0015060000	(71)Name of Applicant : 1)Mahindra & Mahindra Limited. Address of Applicant :Farm Equipment Sector, Swaraj Division, Phase IV, Industrial Area, S.A.S. Nagar (Mohali), Punjab, India Punjab India
(31) Priority Document No	:NA	(72)Name of Inventor :
(32) Priority Date	:NA	1)Bob Vashist
(33) Name of priority country	:NA	2)Abhishek Wadhwa
(86) International Application No	:NA	
Filing Date	:NA	
(87) International Publication No	: NA	
(61) Patent of Addition to Application Number:	NA	
Filing Date	:NA	
(62) Divisional to Application Number	:NA	
Filing Date	:NA	

(57) Abstract :

A tool and a method for gripping vehicle structural members. The tool 100 includes a first member 102 having a supporting arm 104 at first end 102a and a head portion 106 at second end 102b, said head portion 106 defines a bore 108a and a slot 108b, a second member 110 connected to said first member 102, said second member 110 defining a receiving pocket 112 at lower end 110a and an engageable portion 114 at upper end 110b, said engageable portion 114 includes a connecting member 116 adapted to slidably engage within said bore 108a, and a locking member 118 disposed between said first member 102 and said second member 110. The supporting arm 104 of said first member 102 and said receiving pocket 112 of said second member 110 are adapted to grip a first portion and a second portion of said vehicle structural members respectively.

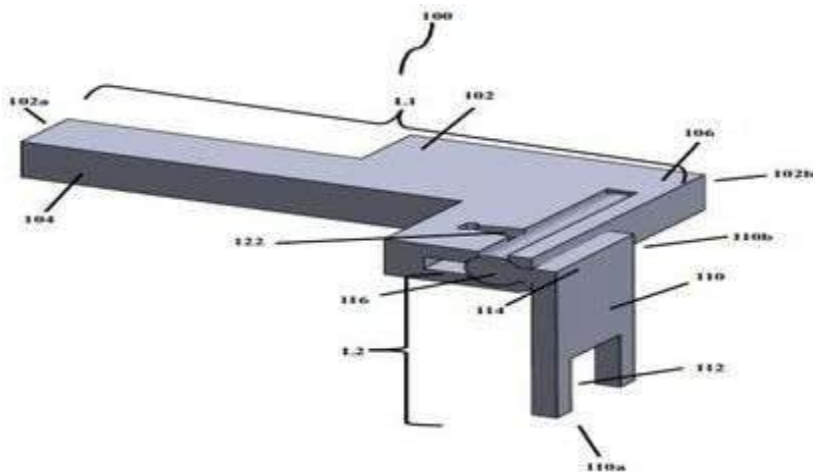

No. of Pages : 23 No. of Claims : 9

(54) Title of the invention : ANTI-OBESITY EFFECT OF EXTRACTS PREPARED FROM FICUS BENGHALENSIS

(51) International classification	:A61K0036600000, A61K0036480000, A61K0036185000, A23L0033105000, A61K0008970000	(71)Name of Applicant : 1)SHOOLINI UNIVERSITY OF BIOTECHNOLOGY AND MANAGEMENT SCIENCES Address of Applicant :VILLAGE- BHAJOL, P.O. SULTANPUR, SOLAN- 173229 (H.P) Himachal Pradesh India
(31) Priority Document No	:NA	(72)Name of Inventor :
(32) Priority Date	:NA	1)AZHAR KHAN
(33) Name of priority country	:NA	2)KESHAV CHANDEL
(86) International Application No	:NA	3)HUMA KHAN
Filing Date	:NA	4)MUKUL KOLISH
(87) International Publication No	: NA	
(61) Patent of Addition to Application Number	:NA	
Filing Date	:NA	
(62) Divisional to Application Number	:NA	
Filing Date	:NA	

(57) Abstract :

This invention relates to anti-obesity extracts prepared from ficus benghalensis. Ficus benghalensis, commonly known as banyan tree and belongs to the family of Moraceae and is an evergreen tree found all over India. Different parts of the plants are used in the treatment of various type of diseases mainly the diabetes. So present study has focused on its potential to improve blood glucose level and can prevent complications of type 2 diabetes mellitus. The in-vitro antioxidant and anti-diabetic properties of plant in two solvents has studied (methanol and distilled water) extracts of Ficus benghalensis leaves. Both the solvent extracts were analysed and contain different phytochemicals. The results showed that methanol was the suitable solvent for extraction of phytochemical as it has more free radical scavenging activity (64.13%). The phytochemical assay results showed the highest polyphenol content in methanol extract (0.56 mg GAE/g) and also flavonoids content in methanol extract (0.31 mg GAE/g). The in-vitro anti diabetic assay was done by in vitro enzymatic method (alpha-amylase inhibition assay) and glucose uptake assay. Ficus benghalensis methanolic extract showed minimum value of IC50 (IC50 = 0.221mg/ml) than its aqueous extracts (IC50 = 0.253 mg/ml). So Ficus benghalensis methanolic extract shows highest amylase inhibition activity than its aqueous extract Further, Ficus benghalensis aqueous extract inhibited the glucose uptake significantly than its methanolic extract when subjected to glucose inhibition assay through a dialysis membrane for 180 hours. Most importantly when in vitro assay was performed to check its antiobesitic nature, so the aqueous extract showed minimum value of IC50 (IC50 = 0.229mg/ml) than its methanolic extracts (IC50 = 0.240mg/ml) which shows its potential for inhibiting lipase enzyme and could be a candidate to cure obesity.

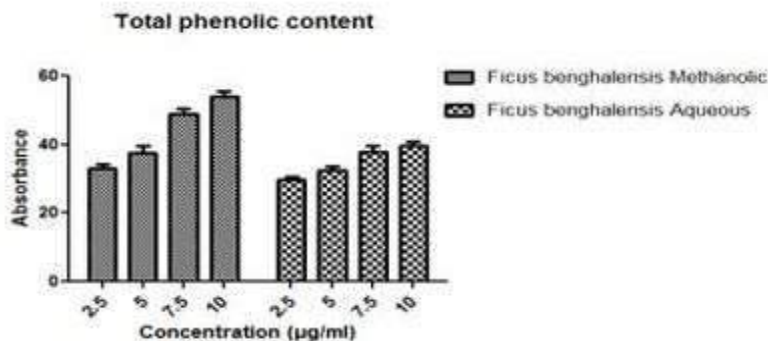
**Fig 1: Total Phenolic Content**

(54) Title of the invention : AN INSILICO METHOD TO ANALYZE POLYPHENOLS FROM CRATAEGUS PINNATIFIDA AS AN ACE INHIBITOR

(51) International classification	:A61K0036734000, A61K0031353000, A61K0031401000, A61K0038550000, C07D0311620000	(71)Name of Applicant : 1)SHOOLINI UNIVERSITY OF BIOTECHNOLOGY AND MANAGEMENT SCIENCES Address of Applicant :VILLAGE- BHAJOL, P.O. SULTANPUR, SOLAN- 173229 (H.P) Himachal Pradesh India
(31) Priority Document No	:NA	(72)Name of Inventor :
(32) Priority Date	:NA	1)AZHAR KHAN
(33) Name of priority country	:NA	2)HUMA KHAN
(86) International Application No	:NA	3)PRATIBHA SHARMA
Filing Date	:NA	4)SAURABH KULSHRESHTHA
(87) International Publication No	: NA	
(61) Patent of Addition to Application Number	:NA	
Filing Date	:NA	
(62) Divisional to Application Number	:NA	
Filing Date	:NA	

(57) Abstract :

This invention relates to an insilico method to analyse polyphenols from crataegus pinnatifida as an ace inhibitor. Proanthocyanidin A2, Procyanidin B2, Procyanidin B4 and Procyanidin B5 compounds were reported from Crataegus pinnatifida fruit having potential antihypertensive inhibitory effect. However, the mechanism via which such compound exerts the effect in blood pressure regulation is still unclear. Therefore, present invention designed to target this compound on Renin angiotensin system a hormonal cascade which regulates the blood pressure. In silico protein-ligand docking of Proanthocyanidin A2, Procyanidin B2, Procyanidin B4 and Procyanidin B5 with angiotensin converting enzyme (both domain N and C) was carried out by autodock tool 1.5.6 and structure of the compounds were drawn by the Marvin sketch 17.21.0 software. The binding of the compounds to the active site of the entire drug target was observed by chimera 1.9. Proanthocyanidin A2, Procyanidin B2, Procyanidin B4 and Procyanidin B5 showed very low binding affinity with angiotensin converting enzyme and partially blocked the active sites of the enzyme. Proanthocyanidin A2, Procyanidin B2, Procyanidin B4 and Procyanidin B5 showed the -11.1kcal/mol, -10.8kcal/mol, -9.9kcal/mol and -11.3kcal/mol with angiotensin converting enzyme (C-domain) and these four compounds shown -10.6kcal/mol, -9.3kcal/mol, -10.5kcal/mol and -10.8kcal/mol with angiotensin converting enzyme (N-domain). Proanthocyanidin A2, Procyanidin B2, Procyanidin B4 and Procyanidin B5 compounds showed good binding energy with angiotensin converting enzyme which is more appropriate in comparison to Captopril (standard) -5.5kcal/mol and Enalapril (standard)-7.5kcal/mol. Findings of the present invention provide new perspective for the drug development against high blood pressure regulation and also showed that angiotensin converting enzyme is very potential drug target for hypertension.



No. of Pages : 24 No. of Claims : 6

(54) Title of the invention : TREATMENT OF METHYLENE BLUE USING MULTIWALLED CARBON NANOTUBES

(51) International classification	:B82Y0030000000, A61B0006030000, C01B0032160000, B82Y0040000000, C01B0032174000	(71) Name of Applicant : 1)AMITY UNIVERSITY Address of Applicant :AMITY UNIVERSITY CAMPUS, SECTOR-125 NOIDA UTTAR PRADESH-201313, INDIA Uttar Pradesh India
(31) Priority Document No	:NA	(72) Name of Inventor :
(32) Priority Date	:NA	1)PREETI THAKUR
(33) Name of priority country	:NA	2)SHALINI BISHT
(86) International Application No	:NA	3)ATUL THAKUR
Filing Date	:NA	
(87) International Publication No	: NA	
(61) Patent of Addition to Application Number	:NA	
Filing Date	:NA	
(62) Divisional to Application Number	:NA	
Filing Date	:NA	

(57) Abstract :

The present invention relates to a system and method of treatment of methylene blue using multiwalled carbon nanotubes. The present invention aims to evaluate the adsorption of MB using multi walled carbon nanotubes MWCNTs at different parameter.

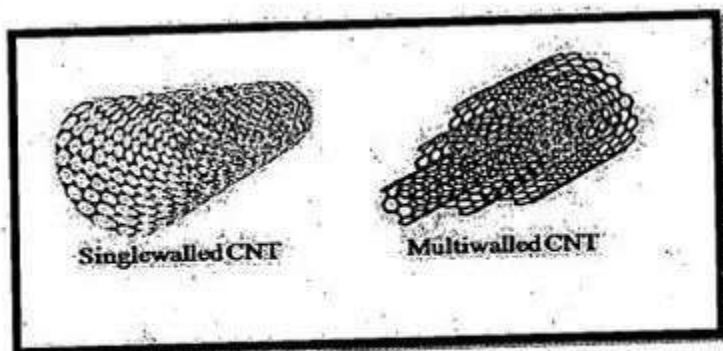

Fig 1

No. of Pages : 22 No. of Claims : 3

(54) Title of the invention : A METHOD TO CULTURE AND IDENTIFY FUSARIUM SOLANI CAUSING STEM ROT AND WILT OF LUCKY BAMBOO (DRACAENA SANDERIANA)

(51) International classification :A61Q0005020000,
A45D0024300000,
G01P0015180000,
A61Q0005060000,
A45D0024020000

(31) Priority Document No :NA
(32) Priority Date :NA
(33) Name of priority country :NA
(86) International Application No :NA
Filing Date :NA
(87) International Publication No : NA
(61) Patent of Addition to Application Number :NA
Filing Date :NA
(62) Divisional to Application Number :NA
Filing Date :NA

(71)**Name of Applicant :**
1)AMITY UNIVERSITY
Address of Applicant :AMITY UNIVERSITY CAMPUS,
SECTOR-125 NOIDA UTTAR PRADESH-201313, INDIA Uttar
Pradesh India

(72)**Name of Inventor :**
1)NARENDRA KUMAR
2)S.M.PAUL KHURANA

(57) Abstract :

The present invention relates to a comb with variable teeth that houses three variable sets. Out of the three, two sets have same pitch of teeth while the one has a different pitch so as to house the other two sets. This proposed variable teeth comb serves different purposes to females as well as male users who prefer multiple combs for hair cleaning, untangling or styling.

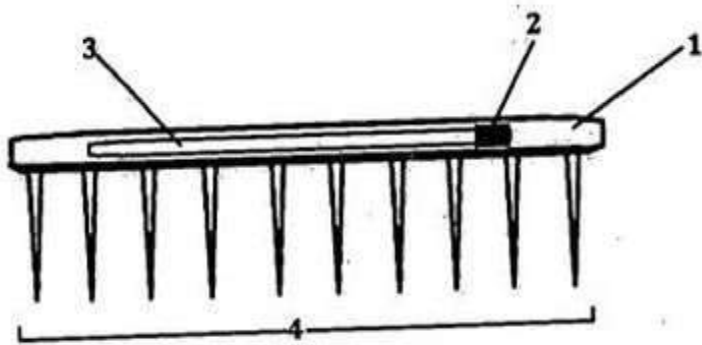

Fig 1

No. of Pages : 11 No. of Claims : 5

(54) Title of the invention : POLY PHYTONATURAL FACIAL CLEANSER

(51) International classification	:A61Q0019100000, A61K0008020000, A61K0036258000, A47K0007030000, B01J0037030000	(71)Name of Applicant : 1)PROF. (DR.) N. V. SATHEESH MADHAV Address of Applicant :FACULTY OF PHARMACY, DIT UNIVERSITY, MUSSORIE DIVERSION ROAD, DEHRADUN, UTTARAKHAND-248009, INDIA Uttarakhand India 2)MR. SIDDHARTH SINGH
(31) Priority Document No	:NA	(72)Name of Inventor :
(32) Priority Date	:NA	1)PROF. (DR.) N. V. SATHEESH MADHAV
(33) Name of priority country	:NA	2)MR. SIDDHARTH SINGH
(86) International Application No	:NA	
Filing Date	:NA	
(87) International Publication No	: NA	
(61) Patent of Addition to Application	:NA	
Number	:NA	
Filing Date	:NA	
(62) Divisional to Application Number	:NA	
Filing Date	:NA	

(57) Abstract :

The current invention explores a method for preparing bio-natural cleanser concentrate dispersions comprising of various vital phytoprinciples which can serve as a natural cleansers. The concentrated cleanser solution was prepared by add mixing phytoprinciples like orange peel powder, coconut pulp, coconut water, sandalwood powder, etc. followed by optimized sonication cycles and incorporated with suitable co-formulating agent which in turned followed by preparing impregnated cleansing wipe with the dilute cleanser in appropriate quality and assist for its cleansing formulation. The poly phytonatural formulation FA2 showed a significance in-vitro cleansing property.

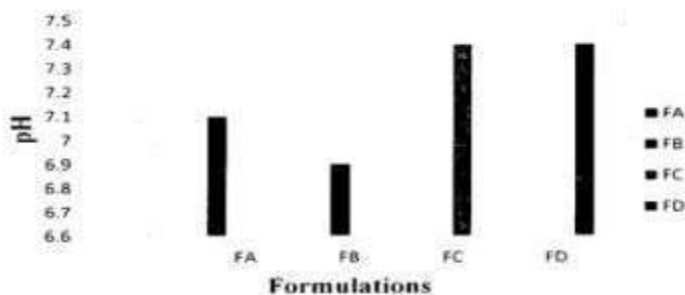
Drawings of the invention**Figure 1 pH of poly phytonatural cleansing formulations**

No. of Pages : 17 No. of Claims : 5

(54) Title of the invention : SPLIT-BAFFLE FOR WIPER HEATING & SUPPRESSING RECIRCULATION ZONES

<p>(51) International classification</p> <p>(31) Priority Document No</p> <p>(32) Priority Date</p> <p>(33) Name of priority country</p> <p>(86) International Application No</p> <p style="padding-left: 20px;">Filing Date</p> <p>(87) International Publication No</p> <p>(61) Patent of Addition to Application Number</p> <p style="padding-left: 20px;">Filing Date</p> <p>(62) Divisional to Application Number</p> <p style="padding-left: 20px;">Filing Date</p>	<p>:F25B0047020000, B60S0001540000, B60H0001340000, B60H0001240000, G09F0009300000</p> <p>:NA</p> <p>:NA</p> <p>:NA</p> <p>:NA</p> <p>:NA</p> <p>: NA</p> <p>:NA</p> <p>:NA</p> <p>:NA</p> <p>:NA</p> <p>:NA</p>	<p>(71)Name of Applicant : 1)Daimler AG Address of Applicant :70546 Stuttgart Germany Germany</p> <p>(72)Name of Inventor : 1)Mr. Amit Anurag 2)Mr. Wolfgang Roessner</p>
---	--	--

(57) Abstract :

A defrosting system 100 for efficient defrosting of windshields in automobiles is disclosed. The defrosting system 100 comprises a defrost air feed 110, a baffle 120, a wiper air feed 130, and a baffle opening 140. The defrost air feed 110 can include a plurality of air channel members 112 configured to selectively channel defrost air over a windshield interior 212. The baffle 120 is a flat plate having four edges and two surfaces. One end of the baffle 120 is closed while the other end is open with the opening being the baffle opening 140 that can allow airflow into a cabin of the automobile. The wiper air feed 130 is configured to provide defrost air to a wiper region on the windshield interior 212. The airflow from the wiper air feed 130 does not affect the airflow from defrost air feed 110.

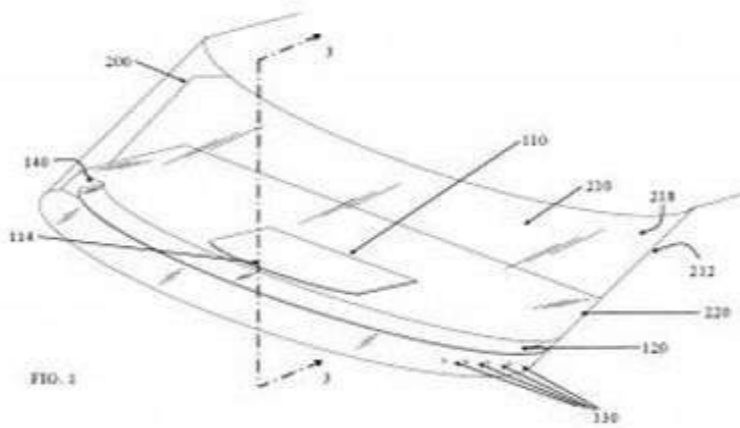

No. of Pages : 15 No. of Claims : 4

(54) Title of the invention : DEVICE TO MEASURE TORSION BAR LINK BALL JOINT ANGLES

(51) International classification	:B60G0021055000, E02F0003430000, F04D0029360000, G01L0005220000, F41G0005240000	(71)Name of Applicant : 1)Daimler AG Address of Applicant :70546 Stuttgart Germany Germany
(31) Priority Document No	:NA	(72)Name of Inventor : 1)Mr. Manish C. Kumar 2)Mr. Deepak Pandey
(32) Priority Date	:NA	
(33) Name of priority country	:NA	
(86) International Application No	:NA	
Filing Date	:NA	
(87) International Publication No	: NA	
(61) Patent of Addition to Application Number	:NA	
Filing Date	:NA	
(62) Divisional to Application Number	:NA	
Filing Date	:NA	

(57) Abstract :

A device 200 for measuring angular movement of ball joints in a torsion bar installation is disclosed. The device 200 includes a control unit 210 that receives kinematic information associated with the torsion bar and decodes co-ordinate values associated with operational positions of ball joints 204-1 and 204-2 of a torsion bar link 202. The ball joints 204-1 and 204-2 of the link 202 are coupled to a first actuator 240-1 and a second actuator 240-2, which move the coupled ball joints 204 to their respective operational positions. A set of sensors 250-1 and 250-2, coupled to the first actuator 240-1 and the second actuator 240-2, measure the tilt and rotational angles of ball studs 206 of the respective ball joints 204.

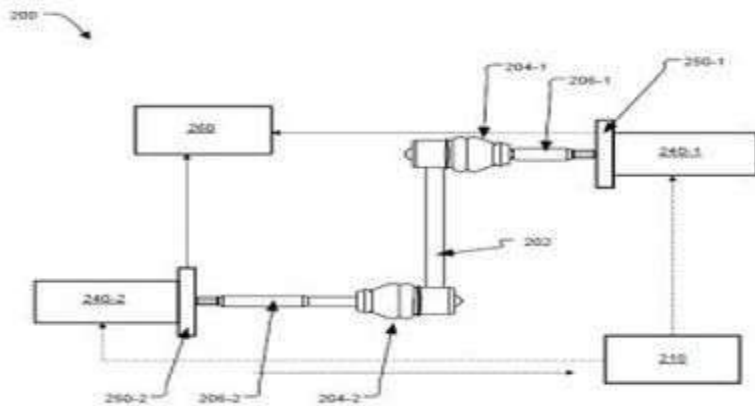

FIG. 2

No. of Pages : 16 No. of Claims : 2

(54) Title of the invention : IMPROVED ROTOR COOLING FOR ELECTRIC MOTORS

<p>(51) International classification</p> <p>(31) Priority Document No</p> <p>(32) Priority Date</p> <p>(33) Name of priority country</p> <p>(86) International Application No</p> <p style="padding-left: 20px;">Filing Date</p> <p>(87) International Publication No</p> <p>(61) Patent of Addition to Application Number</p> <p style="padding-left: 20px;">Filing Date</p> <p>(62) Divisional to Application Number</p> <p style="padding-left: 20px;">Filing Date</p>	<p>:H02K0001320000, H02K0001270000, F04D0029058000, H02K0001300000, F01D0005080000</p> <p>:NA</p> <p>:NA</p> <p>:NA</p> <p>:NA</p> <p>:NA</p> <p>: NA</p> <p>:NA</p> <p>:NA</p> <p>:NA</p> <p>:NA</p> <p>:NA</p>	<p>(71)Name of Applicant : 1)Daimler AG Address of Applicant :70546 Stuttgart Germany Germany</p> <p>(72)Name of Inventor : 1)Mr. Ravi Dharwad</p>
---	--	--

(57) Abstract :

An improved rotor assembly 200 for an electric motor is disclosed. The rotor assembly 200 comprises a rotor shaft 202 having an axial bore 204 to allow flow of a coolant media towards a first end of the rotor assembly 200, and a plurality of rotor sheets 206. An inner circumference of the rotor sheets 206 are configured such that when the rotor sheets 206 are fitted on the rotor shaft 202 in a form of stack, passages 208 for flow of the coolant media are created between an inner periphery of the rotor sheets 206 and an outer periphery of the rotor shaft 206 to cool the rotor assembly. The passages 208 are fluidically coupled to the axial bore 204 through radial holes 210 of the rotor shaft 202, and configured to carry the coolant media towards a second end of the rotor assembly 200 from the first end.

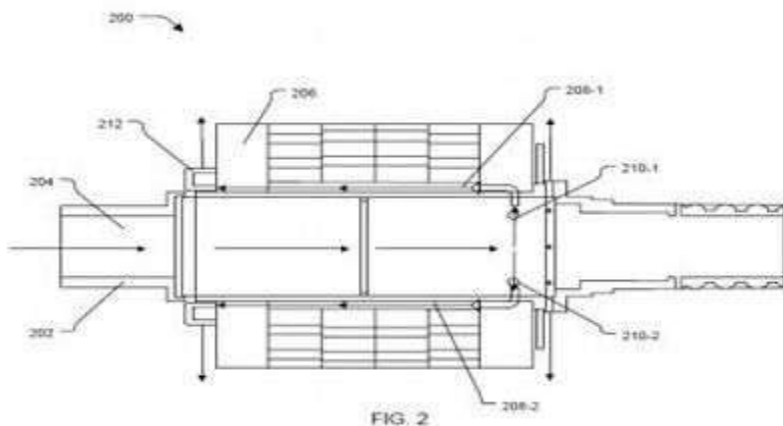

No. of Pages : 14 No. of Claims : 8

(54) Title of the invention : HOLDING ASSEMBLY FOR VEHICLES FOR HOLDING A PORTABLEELECTRONIC DEVICE

<p>(51) International classification</p> <p>(31) Priority Document No</p> <p>(32) Priority Date</p> <p>(33) Name of priority country</p> <p>(86) International Application No</p> <p style="padding-left: 20px;">Filing Date</p> <p>(87) International Publication No</p> <p>(61) Patent of Addition to Application Number</p> <p style="padding-left: 20px;">Filing Date</p> <p>(62) Divisional to Application Number</p> <p style="padding-left: 20px;">Filing Date</p>	<p>:B60N0002750000, B60R0011020000, B60R0011000000, B60N0003000000, A41D0003020000</p> <p>:NA</p> <p>:NA</p> <p>:NA</p> <p>:NA</p> <p>:NA</p> <p>:NA</p> <p>:NA</p> <p>:NA</p> <p>:NA</p> <p>:NA</p> <p>:NA</p>	<p>(71)Name of Applicant : 1)Daimler AG Address of Applicant :70546 Stuttgart Germany Germany</p> <p>(72)Name of Inventor : 1)Mr. Nanda Kishore Panda 2)Mr. Rishab Raj 3)Mr. Joel Aranha</p>
---	---	--

(57) Abstract :

An improved holding assembly for a vehicle for holding a portable electronic device 106 is disclosed. The disclosed holding assembly comprising a pocket 102 in an armrest 104 of a vehicle seat to accommodate the portable electronic device 106; and a slider 112 slidably configured with a guide 110 to move between a retracted position in which the slider 112 allows unhindered positioning or removal of the portable electronic device 106 from the pocket 102, and an extended position in which the slider 112 covers at least partially an open end of the pocket 102 to prevent the device 106 from flying out of the pocket 102. The slider 112 has a predefined mass such that, in the event of the crash, a momentum of the slider 112 overcomes the holding force of at last one clip 202 to move by itself to the extended position from the retracted position.

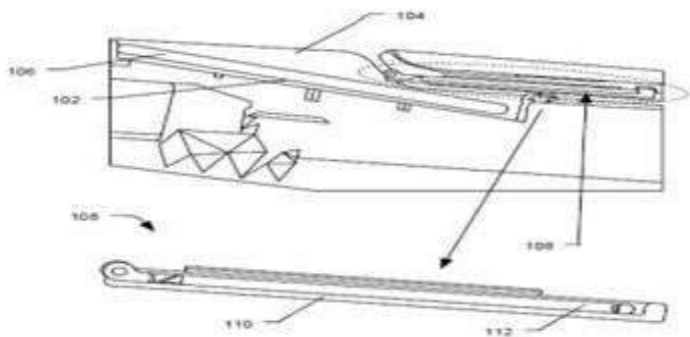

FIG. 1

No. of Pages : 12 No. of Claims : 10

(54) Title of the invention : NANOEMULSION COMPOSITION FOR PEST MANAGEMENT

(51) International classification	:A61K0009107000, A61K0031000000, A23K0050750000, A61K0008060000, A61K0031050000	(71) Name of Applicant : 1)Indian Council of Agricultural Research Address of Applicant :ICAR, Krishi Bhavan, Dr. Rajendra Prasad Road, New Delhi - 110001, India. Delhi India
(31) Priority Document No	:NA	(72) Name of Inventor :
(32) Priority Date	:NA	1)KESAVAN SUBAHARAN
(33) Name of priority country	:NA	2)M.ESWARAMOORTHY
(86) International Application No	:NA	3)N.BAKTHAVATSALAM
Filing Date	:NA	4)G.SIVAKUMAR
(87) International Publication No	: NA	
(61) Patent of Addition to Application Number	:NA	
Filing Date	:NA	
(62) Divisional to Application Number	:NA	
Filing Date	:NA	

(57) Abstract :

The present disclosure provides a nanoemulsion composition comprising an ajowan oil, or thymol with a surfactant for management of pests for example *Musca domestica*, especially in poultry and animal farms. The nanoemulsion composition as per the present disclosure comprising ajowan oil or thymol having homogeneous distribution of droplet size in the range of 20 nm to 500 nm is stable and capable of exhibiting superior repellence effect on pest like *Musca domestica* for its effective control in environmentally friendly manner. The present disclosure also provides a process for providing the nanoemulsion composition of ajowan oil or thymol.

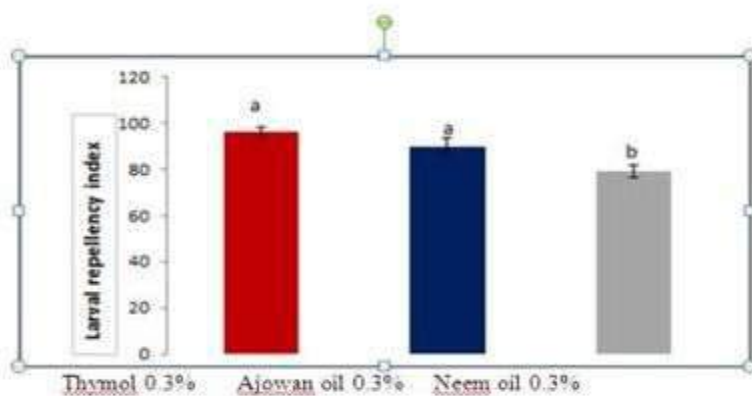

Figure 4

No. of Pages : 33 No. of Claims : 23

(12) PATENT APPLICATION PUBLICATION

(21) Application No.201911051084 A

(19) INDIA

(22) Date of filing of Application :10/12/2019

(43) Publication Date : 11/06/2021

(54) Title of the invention : DEVICE FOR CABLE INSTALLATION / DE-INSTALLATION

(51) International classification	:G01R0031080000, H02G0001100000, H02G0001080000, G02B0006440000, G06F0009440100	(71) Name of Applicant : 1)Sterlite Power Transmission Limited Address of Applicant :F-2 Mira Corporate Suits Ishwar Nagar, New Delhi New Delhi India 110065 Delhi India
(31) Priority Document No	:NA	(72) Name of Inventor :
(32) Priority Date	:NA	1)Rajat Kumar Pradhan
(33) Name of priority country	:NA	2)Rajan Kumar
(86) International Application No	:NA	
Filing Date	:NA	
(87) International Publication No	: NA	
(61) Patent of Addition to Application Number	:NA	
Filing Date	:NA	
(62) Divisional to Application Number	:NA	
Filing Date	:NA	

(57) Abstract :

The present disclosure relates to a field of device for cable installation / de-installation and more particular to a device for installation / de-installation of cable between power transmission towers.

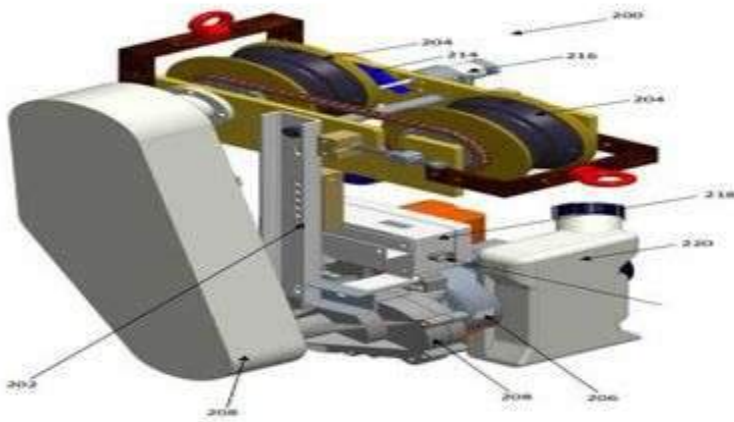

No. of Pages : 24 No. of Claims : 24

(54) Title of the invention : DEVICE FOR HOUSING SCR LINES IN AUTOMOBILES

<p>(51) International classification</p> <p>(31) Priority Document No</p> <p>(32) Priority Date</p> <p>(33) Name of priority country</p> <p>(86) International Application No Filing Date</p> <p>(87) International Publication No</p> <p>(61) Patent of Addition to Application Number Filing Date</p> <p>(62) Divisional to Application Number Filing Date</p>	<p>:F01N0013000000, F01N0003200000, H04M0001020000, G06F0001160000, H01R0024200000</p> <p>:NA</p> <p>:NA</p> <p>:NA</p> <p>:NA</p> <p>:NA</p> <p>:NA</p> <p>:NA</p> <p>:NA</p> <p>:NA</p> <p>:NA</p> <p>:NA</p>	<p>(71)Name of Applicant : 1)Daimler AG Address of Applicant :70546 Stuttgart Germany Germany</p> <p>(72)Name of Inventor : 1)Mr. Rahul Manekar 2)Mr. Praveen Chandra Vijapurapu 3)Mr. Rohan Devan 4)Ms. Sonia Chaudhri</p>
--	---	--

(57) Abstract :

A device 100 for housing selective catalytic reduction (SCR) lines in an automobile is proposed. The device 100 comprises a first housing 110, a second housing 120, a spacer member 130, and a housing cover 140. The first housing 110 is configured to receive a first SCR line 112, with the first housing 110 being further configured to restrict the first SCR line 112 from releasing after being received. The second housing 120 is configured to receive a second SCR line 122. The second housing 120 is disposed diagonally with respect to the first housing 110 such that the first housing 110 is axially parallel to the second housing 120. The spacer member 130 is disposed between the first housing 110 and the second housing 120. The housing cover 140 is configured to cover the first housing 110 and the second housing 120 in an assembled position.

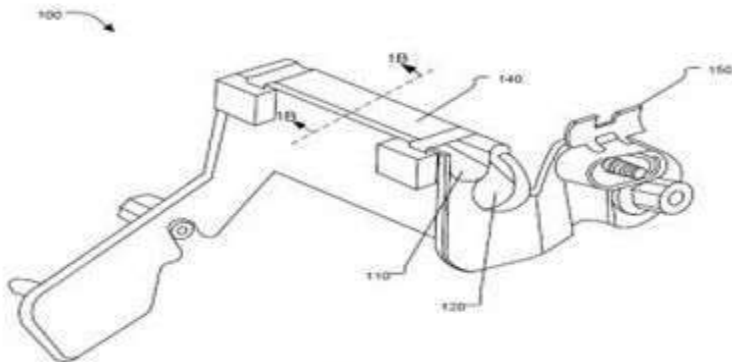

FIG. 1A

No. of Pages : 19 No. of Claims : 7

(54) Title of the invention : CUP-SHAPED TOOL COMPONENT

(51) International classification	:B24B0023020000, B23B0031000000, B25B0023000000, B22F0005000000, B24D0015020000	(71) Name of Applicant : 1)INDIAN INSTITUTE OF TECHNOLOGY DELHI Address of Applicant :Hauz Khas, New Delhi 110016, India Delhi India
(31) Priority Document No	:NA	(72) Name of Inventor :
(32) Priority Date	:NA	1)JHA, Sunil
(33) Name of priority country	:NA	2)VERMA, Tarun
(86) International Application No	:NA	3)CHAWLA, Onkar
Filing Date	:NA	
(87) International Publication No	: NA	
(61) Patent of Addition to Application Number	:NA	
Filing Date	:NA	
(62) Divisional to Application Number	:NA	
Filing Date	:NA	

(57) Abstract :

The present subject matter relates to a cup-shaped tool component (100, 800) which is couplable to a rotary adaptor (300a) of a surface finishing tool for a nano-level surface finishing of surfaces (612). The tool component (100, 800) is made of an elastomeric medium (614). The tool component (100, 800) includes a base portion (104, 404, 504) which is embedded with abrasive particles (102), and at least one protrusion (106) formed on an inner surface (108) of the tool component (100, 800). The at least one protrusion (106) is to couple the tool component (100, 800) to the rotary adaptor (300a) of the surface finishing tool for providing rotation to the tool component (100, 800) in conjunction with the rotation of the rotary adaptor (300a).

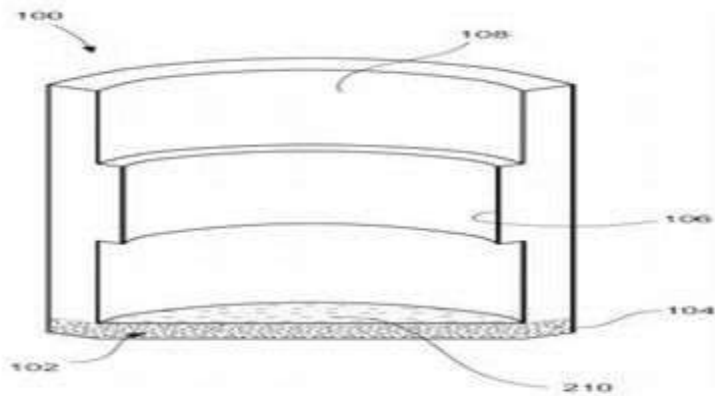

FIG. 2

No. of Pages : 28 No. of Claims : 20

(12) PATENT APPLICATION PUBLICATION

(21) Application No.202014002872 A

(19) INDIA

(22) Date of filing of Application :22/01/2020

(43) Publication Date : 11/06/2021

(54) Title of the invention : NEW-TYPE WATERWHEEL ROTATING DEVICE

(51) International classification	:F03B0017020000, B66F0007080000, F03G0007100000, B23Q0001520000, F01B0013060000	(71)Name of Applicant : 1)XIN, Xiaofei Address of Applicant :New Power Bureau Building, Fuping Town, Baoding, Hebei 071000, China China
(31) Priority Document No	:201922150041.X	(72)Name of Inventor : 1)XIN, Xiaofei
(32) Priority Date	:05/12/2019	
(33) Name of priority country	:China	
(86) International Application No	:NA	
Filing Date	:NA	
(87) International Publication No	: NA	
(61) Patent of Addition to Application Number	:NA	
Filing Date	:NA	
(62) Divisional to Application Number	:NA	
Filing Date	:NA	

(57) Abstract :

The present utility model discloses a new-type waterwheel rotating device, comprising a supporting plate, a rotating shaft, a rotating frame, a reinforcing ring and a power supply device, wherein the rotating frame comprises a rotating ring and rotating brackets, the rotating ring and the several rotating brackets being all fixedly connected, and one ends of the several rotating brackets being welded to a first cylinder assembly, a second cylinder assembly, a third cylinder assembly, a fourth cylinder assembly, a fifth cylinder assembly, a sixth cylinder assembly, a seventh cylinder assembly and an eighth cylinder assembly; and the first cylinder assembly comprises a cylinder, a seal pipe, a vent pipe, a water outlet and a water inlet, the cylinder being connected to the seal pipe, and the vent pipe being connected to the other end of the seal pipe. By means of air suction and water discharge through the piston motion of the cylinders, the vacuum cylinders under water float upwards. The cylinders above water discharge air and enter the water, which circulate in turn to make the waterwheel rotate continuously. The most important feature of this waterwheel is to utilize the buoyancy of water.

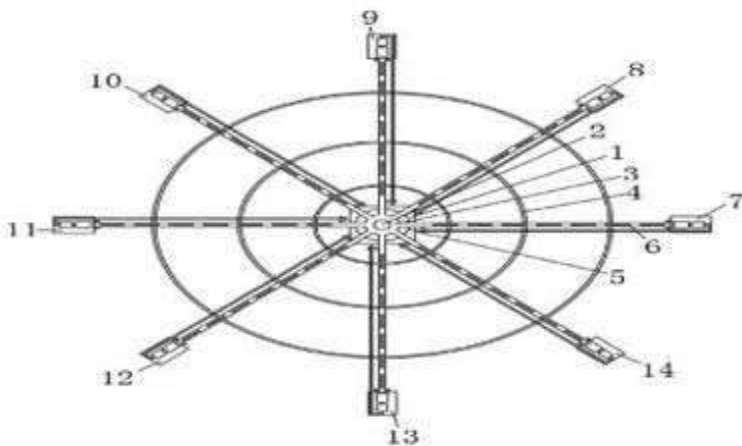

No. of Pages : 8 No. of Claims : 3

(12) PATENT APPLICATION PUBLICATION

(21) Application No.202014024687 A

(19) INDIA

(22) Date of filing of Application :12/06/2020

(43) Publication Date : 11/06/2021

(54) Title of the invention : DOOR LOCKING STRUCTURE •

(51) International classification	:G07F0019000000, G07C0009000000, E05B0063000000, G10L0015260000, E05C0019180000	(71) Name of Applicant : 1)HYUNDAI MOTOR COMPANY Address of Applicant :12 Heolleung-ro, Seocho-gu, Seoul 06797, Republic of Korea 2)KIA MOTORS CORPORATION
(31) Priority Document No	:10-2019-0163264	(72) Name of Inventor :
(32) Priority Date	:10/12/2019	1)CHO, Ki Hyun
(33) Name of priority country	:Republic of Korea	2)CHO, Eui Chan
(86) International Application No	:NA	
Filing Date	:NA	
(87) International Publication No	: NA	
(61) Patent of Addition to Application Number	:NA	
Filing Date	:NA	
(62) Divisional to Application Number	:NA	
Filing Date	:NA	

(57) Abstract :

A door locking structure includes a door located at a side of a vehicle, a locking unit provided at the door, an input unit configured to apply unlocking input to the locking unit, and a controller configured to receive the input through the input unit and to unlock the locking unit, wherein the controller is configured to integrally unlock the locking unit in response to the input through the input unit.

No. of Pages : 34 No. of Claims : 20

(12) PATENT APPLICATION PUBLICATION

(21) Application No.202014025021 A

(19) INDIA

(22) Date of filing of Application :15/06/2020

(43) Publication Date : 11/06/2021

(54) Title of the invention : BIDIRECTIONAL DOOR OPENING MODULE •

(51) International classification	:F25D0023020000, E05F0001100000, E05D0011000000, E05D0015160000, G01S0007481000	(71) Name of Applicant : 1)HYUNDAI MOTOR COMPANY Address of Applicant :12 Heolleung-ro, Seocho-gu, Seoul 06797, Republic of Korea Republic of Korea 2)KIA MOTORS CORPORATION
(31) Priority Document No	:10-2019-0163265	(72) Name of Inventor :
(32) Priority Date	:10/12/2019	1)CHO, Ki Hyun
(33) Name of priority country	:Republic of Korea	2)JUNG, Chung Hwa
(86) International Application No	:NA	
Filing Date	:NA	
(87) International Publication No	: NA	
(61) Patent of Addition to Application Number:	:NA	
Filing Date	:NA	
(62) Divisional to Application Number	:NA	
Filing Date	:NA	

(57) Abstract :

A bidirectional door opening module includes a vehicle body panel located between a first door configured to be rotated to open one end of a vehicle and a second door configured to be rotated to open a remaining end of the vehicle, and a drive unit coupled to the vehicle body panel and configured to apply opening force to the first door and the second door, wherein the drive unit includes a driver configured to apply driving force so as to open the first door or the second door, rail units configured to receive the driving force of the driver and then to apply opening force to the first door or the second door, and hinge units coupled to the rail units and configured to perform rotary opening of the first door or the second door.

No. of Pages : 30 No. of Claims : 20

(54) Title of the invention : ULTRASOUND DIAGNOSTIC APPARATUS BODY

(51) International classification	:G01N0033533000, H05B0031000000, B01J0020286000, C02F0003280000, B63C0007260000	(71) Name of Applicant : 1)Hitachi, Ltd. Address of Applicant :6-6, Marunouchi 1-chome, Chiyoda-ku, Tokyo 100-8280, Japan Japan
(31) Priority Document No	:2019-220715	(72) Name of Inventor :
(32) Priority Date	:05/12/2019	1)Hidenao KUBOTA
(33) Name of priority country	:Japan	2)Shintaro TAKEHARA
(86) International Application No	:NA	3)Katsunori ASAFUSA
Filing Date	:NA	
(87) International Publication No	: NA	
(61) Patent of Addition to Application Number	:NA	
Filing Date	:NA	
(62) Divisional to Application Number	:NA	
Filing Date	:NA	

(57) Abstract :

In an ultrasound diagnostic apparatus body to which various monitors can be connected, an image quality of an ultrasound image displayed on the monitor is adapted 5 according to the monitor. When a monitor (16) is connected to an apparatus body (12), a controller (50) of the monitor (16) transmits EDID information (44) to the apparatus body (12). A display control unit (30) specifies, based on monitor identification information included in the received EDID information (44), an image quality parameter correlated to the monitor identification information from among image quality parameter information 10 (52). The display control unit (30) transmits image quality information indicating the specified image quality parameter set to the monitor (16) along with the ultrasound image formed by an image former (24). The controller (50) of the monitor (16) determines a display setting of a display (48) based on the image quality information transmitted from the apparatus body (12), and causes the ultrasound image transmitted from the apparatus 15 body (12) to be displayed on the display (48).

No. of Pages : 38 No. of Claims : 9

(12) PATENT APPLICATION PUBLICATION

(21) Application No.202014025996 A

(19) INDIA

(22) Date of filing of Application :19/06/2020

(43) Publication Date : 11/06/2021

(54) Title of the invention : STRADDLED VEHICLE

(51) International classification	:B62J0035000000, B62K0011100000, B62K0011040000, B62K0005010000, B60J0007043000	(71) Name of Applicant : 1)YAMAHA HATSUDOKI KABUSHIKI KAISHA Address of Applicant :2500 Shingai, Iwata-shi, Shizuoka 4388501 Japan Japan
(31) Priority Document No	:JP 2019-127811	(72) Name of Inventor :
(32) Priority Date	:09/07/2019	1)TASPON TANTITAWEEPORN
(33) Name of priority country	:Japan	2)TANAKORN PHUAKNOY
(86) International Application No	:NA	
Filing Date	:NA	
(87) International Publication No	: NA	
(61) Patent of Addition to Application Number	:NA	
Filing Date	:NA	
(62) Divisional to Application Number	:NA	
Filing Date	:NA	

(57) Abstract :

A straddled vehicle includes a vehicle body frame, a side cover, a fuel tank and a tank cover. The vehicle body frame includes a main frame and a rear frame. The main frame extends backward from the head pipe. The rear frame extends backward from the main frame. The side cover is fixed to the vehicle body frame. The fuel tank is supported by the vehicle body frame. The tank cover is connected to the fuel tank and includes a cover body 10 disposed directly above the side cover in order to cover the fuel tank. The side cover includes at least one cover fastening portion and at least one frame fastening portion. The at least one cover fastening portion is fixed to the tank cover and is disposed to overlap with the tank cover in a vehicle side view. The at least one frame fastening portion is fixed to the vehicle body frame and is disposed below the at least one cover fastening portion

No. of Pages : 26 No. of Claims : 11

(12) PATENT APPLICATION PUBLICATION

(21) Application No.202014030199 A

(19) INDIA

(22) Date of filing of Application :15/07/2020

(43) Publication Date : 11/06/2021

(54) Title of the invention : CAMERA MODULE

(51) International classification	:C07D0403120000, H04W0036220000, C07D0403140000, C07D0417060000, C07D0413040000	(71) Name of Applicant : 1)SAMSUNG ELECTRO-MECHANICS CO., LTD. Address of Applicant :Maeyoung-ro 150 (Maetan-dong), Youngtong-gu, Suwon-si, Gyeonggi-do, Republic of Korea
(31) Priority Document No	:10-2019-0164033	(72) Name of Inventor :
(32) Priority Date	:10/12/2019	1)Bo Sung SEO
(33) Name of priority country	:Republic of Korea	2)Hong Joo LEE
(86) International Application No	:NA	3)Young Bok YOON
Filing Date	:NA	4)Jung Seok LEE
(87) International Publication No	: NA	
(61) Patent of Addition to Application Number	:NA	
Filing Date	:NA	
(62) Divisional to Application Number	:NA	
Filing Date	:NA	

(57) Abstract :

A camera module includes a carrier supported on a housing and movable in an optical axis direction, at least one frame supported on the carrier and movable, relative to the carrier, in at least one direction perpendicular to the optical axis direction, and a lens module supported on the frame. The frame is supported on the carrier such that attractive force acts in the at least one direction perpendicular to the optical axis direction.

No. of Pages : 43 No. of Claims : 19

(12) PATENT APPLICATION PUBLICATION

(21) Application No.202014030598 A

(19) INDIA

(22) Date of filing of Application :17/07/2020

(43) Publication Date : 11/06/2021

(54) Title of the invention : CAMERA MODULE

(51) International classification	:C07D0403120000, H04W0036220000, C07D0403140000, C07D0417060000, C07D0413040000	(71) Name of Applicant : 1)SAMSUNG ELECTRO-MECHANICS CO., LTD. Address of Applicant :Maeyoung-ro 150 (Maetan-dong), Youngtong-gu, Suwon-si, Gyeonggi-do, Republic of Korea
(31) Priority Document No	:10-2019-0164032	(72) Name of Inventor :
(32) Priority Date	:10/12/2019	1)Bo Sung SEO
(33) Name of priority country	:Republic of Korea	2)Jung Seok LEE
(86) International Application No	:NA	3)Young Bok YOON
Filing Date	:NA	
(87) International Publication No	: NA	
(61) Patent of Addition to Application Number	:NA	
Filing Date	:NA	
(62) Divisional to Application Number	:NA	
Filing Date	:NA	

(57) Abstract :

A camera module includes a carrier supported on a housing and movable in an optical axis direction, a frame supported on the carrier and movable, relative to the carrier, in a first direction perpendicular to the optical axis direction, and a lens module supported on the frame and movable, relative to the frame, in a second direction perpendicular to the optical axis direction. One of the frame and the lens module is supported such that attractive force acts in one of the first direction and the second direction.

No. of Pages : 30 No. of Claims : 20

(12) PATENT APPLICATION PUBLICATION

(21) Application No.202014039899 A

(19) INDIA

(22) Date of filing of Application :15/09/2020

(43) Publication Date : 11/06/2021

(54) Title of the invention : OPENING STRUCTURE FOR LOWER DOOR •

(51) International classification	:B60R0013040000, B60R0013020000, H01J0037340000, B60R0011000000, H04M0001020000	(71) Name of Applicant : 1)HYUNDAI MOTOR COMPANY Address of Applicant :12 Heolleung-ro, Seocho-gu, Seoul 06797, Republic of Korea 2)KIA MOTORS CORPORATION
(31) Priority Document No	:10-2019-0161209	(72) Name of Inventor :
(32) Priority Date	:06/12/2019	1)RAMPALLI, Sudhir
(33) Name of priority country	:Republic of Korea	2)CHO, Ki Hyun
(86) International Application No	:NA	3)JUNG, Chung hwa
Filing Date	:NA	
(87) International Publication No	: NA	
(61) Patent of Addition to Application Number	:NA	
Filing Date	:NA	
(62) Divisional to Application Number	:NA	
Filing Date	:NA	

(57) Abstract :

ABSTRACT OPENING STRUCTURE FOR LOWER DOOR An opening structure includes a lower door having an upper end configured to be rotated and opened with respect to a lower surface of a vehicle body, a garnish unit located on a surface of the lower door, at least a portion of a lower end of the garnish unit configured to be tilted from the lower door, a driving unit extending in a longitudinal direction and configured to apply driving force to the lower door and the garnish unit, a first driver configured to tilt the garnish unit, a second driver configured to integrally pop up the tilted garnish unit and the lower door and to apply opening force thereto, and a hinge arm connecting the first driver and the second driver to each other.

No. of Pages : 33 No. of Claims : 20

(12) PATENT APPLICATION PUBLICATION

(21) Application No.202014039970 A

(19) INDIA

(22) Date of filing of Application :15/09/2020

(43) Publication Date : 11/06/2021

(54) Title of the invention : DRIVING CIRCUIT

(51) International classification	:G11C0019000000, G02B0021360000, G06F0009380000, G06F0001329600, H05B0037020000	(71) Name of Applicant : 1)AU Optronics Corporation Address of Applicant :NO. 1, LI-HSIN ROAD 2, SCIENCE- BASED INDUSTRIAL PARK, HSIN-CHU, TAIWAN
(31) Priority Document No	:108144792	(72) Name of Inventor :
(32) Priority Date	:06/12/2019	1)Wei-Li LIN
(33) Name of priority country /region	:Taiwan	2)Che-Wei TUNG
(86) International Application No	:NA	
Filing Date	:NA	
(87) International Publication No	: NA	
(61) Patent of Addition to Application Number	:NA	
Filing Date	:NA	
(62) Divisional to Application Number	:NA	
Filing Date	:NA	

(57) Abstract :

ABSTRACT OF THE DISCLOSURE DRIVING CIRCUIT A driving circuit includes a S stage register, a first connect line, a (S+A) stage register and a second connect line. The S stage register receives a S stage control signal through a first switch unit and a second switch unit, so that the S stage register performs voltage regulation and outputs a S stage scan signal. The first connect line is electrically connected to the first switch unit of the S stage register. A third switch unit of the (S+A) stage register is electrically connected to the first connect line and a fourth switch unit of the (S+A) stage register for receiving the S stage scan signal, so that The (S+A) stage register performs voltage regulation. The second connect line is electrically connected to the second switch unit of the S stage register and the fourth switch unit of the (S+A) stage register.

No. of Pages : 26 No. of Claims : 10

(12) PATENT APPLICATION PUBLICATION

(21) Application No.202014040322 A

(19) INDIA

(22) Date of filing of Application :17/09/2020

(43) Publication Date : 11/06/2021

(54) Title of the invention : VEHICLE BODY

(51) International classification	:B62D0025080000, B60R0016020000, B62D0021150000, B62D0021180000, B62D0025140000	(71) Name of Applicant : 1)HYUNDAI MOTOR COMPANY Address of Applicant :12, Heolleung-ro, Seocho-gu, Seoul 06797, Republic of Korea Republic of Korea 2)KIA MOTORS CORPORATION
(31) Priority Document No	:10-2019-0160979	(72) Name of Inventor :
(32) Priority Date	:05/12/2019	1)KIM, Won Oh
(33) Name of priority country	:Republic of Korea	2)KIM, Ho Yeon
(86) International Application No	:NA	3)KIM, Byung Gyu
Filing Date	:NA	4)HEO, Chul Hee
(87) International Publication No	: NA	
(61) Patent of Addition to Application Number	:NA	
Filing Date	:NA	
(62) Divisional to Application Number	:NA	
Filing Date	:NA	

(57) Abstract :

VEHICLE BODY • A vehicle body includes a rigid member having a tubular shape that is closed in cross-section. The rigid member includes a front member, a dash cross member, a rear member, and a center member, which form main frames at the front, rear, and center of the bottom of the vehicle body. The rigid member also includes pillar members that form main frames at both sides of the top of the vehicle body. Connecting members that each have a tubular shape that is open at one surface thereof are connected to the members of the rigid member.

No. of Pages : 31 No. of Claims : 19

(54) Title of the invention : BODY FOR VEHICLE

(51) International classification	:B62D0025200000, F23C0006040000, G02B0006440000, H01L0021680000, B64C0001060000	(71) Name of Applicant : 1)HYUNDAI MOTOR COMPANY Address of Applicant :12, Heolleung-ro, Seocho-gu, Seoul 06797, Republic of Korea Republic of Korea 2)KIA MOTORS CORPORATION
(31) Priority Document No	:10-2019-0160983	(72) Name of Inventor :
(32) Priority Date	:05/12/2019	1)KIM, Byung Gyu
(33) Name of priority country	:Republic of Korea	2)KIM, Won Oh
(86) International Application No	:NA	
Filing Date	:NA	
(87) International Publication No	: NA	
(61) Patent of Addition to Application Number	:NA	
Filing Date	:NA	
(62) Divisional to Application Number	:NA	
Filing Date	:NA	

(57) Abstract :

A body for a vehicle includes a first member provided at a lower portion of a front floor module extending to a front of a second member provided at a center floor module, and a third member provided at a lower portion of a rear floor module extending to a rear of the second member provided at the center floor module to form a main load path along the first, second, and third members extending from a foremost end of the vehicle to a hindmost end of the vehicle.

No. of Pages : 31 No. of Claims : 20

(12) PATENT APPLICATION PUBLICATION

(21) Application No.202014045185 A

(19) INDIA

(22) Date of filing of Application :16/10/2020

(43) Publication Date : 11/06/2021

(54) Title of the invention : DISPLAY DEVICE

(51) International classification	:G02F0001134500, G09G0003360000, H01L0027320000, H02H0009000000, G09G0005000000	(71) Name of Applicant : 1)AU Optronics Corporation Address of Applicant :NO. 1, LI-HSIN ROAD 2, SCIENCE- BASED INDUSTRIAL PARK, HSIN-CHU, TAIWAN
(31) Priority Document No	:108144203	(72) Name of Inventor :
(32) Priority Date	:04/12/2019	1)Chin-Hao CHANG
(33) Name of priority country /region	:Taiwan	2)Wei-Li LIN
(86) International Application No	:NA	
Filing Date	:NA	
(87) International Publication No	: NA	
(61) Patent of Addition to Application Number:	:NA	
Filing Date	:NA	
(62) Divisional to Application Number	:NA	
Filing Date	:NA	

(57) Abstract :

ABSTRACT DISPLAY DEVICE A display device is provided. The display device includes an internal driving circuit, an external circuit and a plurality of signal lines. The signal lines are electrically connected with the internal driving circuit and the external circuit. Each signal line includes N signal line sections, Ma first turning points and Mb second turning points, wherein the N signal line sections are connected with each other, each of the Ma first turning points and the Mb second turning points is located at the connecting site of the two adjacent signal line sections, N and Ma are positive integers, Mb is 0 or a positive integer, N^3 , Ma^2 , $Ma+MbN-1$, the resistance change rate between the two adjacent signal line sections connected with each first turning point is R, and 0

No. of Pages : 37 No. of Claims : 10

(12) PATENT APPLICATION PUBLICATION

(21) Application No.202014047350 A

(19) INDIA

(22) Date of filing of Application :29/10/2020

(43) Publication Date : 11/06/2021

(54) Title of the invention : REFRIGERATOR

(51) International classification	:F25D0017060000, F25D0011020000, F25D0017040000, F25C0001000000, F25D0017080000	(71) Name of Applicant : 1)LG ELECTRONICS INC. Address of Applicant :128, Yeoui-daero, Yeongdeungpo-gu, Seoul, 07336, Republic of Korea Republic of Korea
(31) Priority Document No	:10-2019-0163005	(72) Name of Inventor :
(32) Priority Date	:09/12/2019	1)Park, Jong Gyu
(33) Name of priority country	:Republic of Korea	2)Kim, Ki hwang
(86) International Application No	:NA	3)Kang, Sung hee
Filing Date	:NA	
(87) International Publication No	: NA	
(61) Patent of Addition to Application Number	:NA	
Filing Date	:NA	
(62) Divisional to Application Number	:NA	
Filing Date	:NA	

(57) Abstract :

ABSTRACT REFRIGERATOR A refrigerator includes a cabinet having a freezing compartment below a refrigerating compartment, an ice making compartment at a side of the refrigerating compartment, an evaporator, a shroud that is disposed at a front side of the evaporator, a grille panel coupled to a front surface of the shroud, a first cool air guide channel defined between the grille panel and the shroud and configured to guide cool air to a freezing compartment, a second cool air guide channel defined between the grille panel and the shroud and configured to guide cool air to the ice making compartment, a freezing fan module disposed between the grille panel and the shroud and configured to supply cool air to the first cool air guide channel, and an ice making fan module disposed between the grille panel and the shroud and configured to supply cool air to the second cool air guide channel.

No. of Pages : 199 No. of Claims : 20

(12) PATENT APPLICATION PUBLICATION

(21) Application No.202014048564 A

(19) INDIA

(22) Date of filing of Application :06/11/2020

(43) Publication Date : 11/06/2021

(54) Title of the invention : TRIBLOCK COPOLYMER CONCENTRATES FOR LUBRICATING OIL COMPOSITIONS

(51) International classification	:C10M0143120000, C08L0053000000, C08F0297040000, A23D0009007000, C10M0101000000	(71) Name of Applicant : 1)INFINEUM INTERNATIONAL LIMITED Address of Applicant :P.O. Box 1, Milton Hill, Abingdon, Oxfordshire OX13 6BB, United Kingdom U.K.
(31) Priority Document No	:16/704,078	(72) Name of Inventor :
(32) Priority Date	:05/12/2019	1)ZHAO, Yi
(33) Name of priority country	:U.S.A.	2)CUI, Jun
(86) International Application No	:NA	3)BRIGGS, Stuart
Filing Date	:NA	4)GALBRAITH, Ewan
(87) International Publication No	: NA	
(61) Patent of Addition to Application Number	:NA	
Filing Date	:NA	
(62) Divisional to Application Number	:NA	
Filing Date	:NA	

(57) Abstract :

A VM concentrate comprising: from about 60 to about 95 parts (and at least 50 wt%) of a diluent oil (e.g., having a KV100 of about 2 cSt to about 40 cSt); and from about 5 parts to about 40 parts (and at least 6.0 wt%) of a linear triblock copolymer characterized by the formula: DTM-PA-D^{TMTM}; wherein DTM represents a block derived from diene, PA represents a block derived from monoalkenyl arene, D^{TMTM} represents a block derived from diene, and the linear triblock copolymer is present in an amount effective to modify a lubricating kinematic viscosity at approximately 100°C (KV100) of the concentrate, and wherein the KV100 of the concentrate is about 3000 cSt or less. The linear triblock copolymer may additionally or alternatively have a thickening efficiency span of at most 0.5.

No. of Pages : 43 No. of Claims : 36

(12) PATENT APPLICATION PUBLICATION

(21) Application No.202014050826 A

(19) INDIA

(22) Date of filing of Application :23/11/2020

(43) Publication Date : 11/06/2021

(54) Title of the invention : DIISOCYANATE COMPOSITION FOR OPTICAL LENS AND PREPARATION METHOD THEREOF •

(51) International classification	:G02B0001040000, C08G0018380000, C08G0018760000, B29D0011000000, G02B0001140000	(71)Name of Applicant : 1)SKC CO., LTD. Address of Applicant :84, Jangan-ro 309beon-gil, Jangan-gu, Suwon-si, Gyeonggi-do 16336, Republic of Korea Republic of Korea
(31) Priority Document No	:10-2019-0162101	2)WOORI FINE CHEM CO., LTD.
(32) Priority Date	:06/12/2019	(72)Name of Inventor :
(33) Name of priority country	:Republic of Korea	1)PAI, Jaeyoung
(86) International Application No	:NA	2)KIM, Jeongmoo
Filing Date	:NA	3)HAN, Hyuk Hee
(87) International Publication No	: NA	4)MYUNG, Jung Hwan
(61) Patent of Addition to Application Number	:NA	
Filing Date	:NA	
(62) Divisional to Application Number	:NA	
Filing Date	:NA	

(57) Abstract :

ABSTRACT DIISOCYANATE COMPOSITION FOR OPTICAL LENS AND PREPARATION METHOD THEREOF According to an embodiment, the pH of a diisocyanate composition and a diamine hydrochloride composition used in the preparation of an optical lens is adjusted to a specific range, whereby it is possible to enhance not only the yield and purity of the diisocyanate composition but also the optical characteristics of the final optical lens by suppressing the striae and cloudiness. Specifically, according to the process of the embodiment, the amount of an aqueous hydrochloric acid solution introduced to the reaction may be adjusted to control the pH of the diisocyanate composition to a desired range, thereby enhancing the yield and purity. Accordingly, the process for preparing a diisocyanate composition according to the embodiment can be applied to the preparation of a plastic optical lens of high quality.

No. of Pages : 47 No. of Claims : 10

(12) PATENT APPLICATION PUBLICATION

(21) Application No.202014051253 A

(19) INDIA

(22) Date of filing of Application :25/11/2020

(43) Publication Date : 11/06/2021

(54) Title of the invention : DIISOCYANATE COMPOSITION, PREPARATION METHOD THEREOF AND OPTICAL MATERIAL USING SAME •

(51) International classification	:G02B0001040000, C08G0018720000, C08G0018380000, C08L0063000000, B32B0027180000	(71)Name of Applicant : 1)SKC CO., LTD. Address of Applicant :84, Jangan-ro 309beon-gil, Jangan-gu, Suwon-si, Gyeonggi-do 16336, Republic of Korea Republic of Korea
(31) Priority Document No	:10-2019-0161447	2)WOORI FINE CHEM CO., LTD.
(32) Priority Date	:06/12/2019	(72)Name of Inventor :
(33) Name of priority country	:Republic of Korea	1)PAI, Jaeyoung
(86) International Application No	:NA	2)KIM, Jeongmoo
Filing Date	:NA	3)HAN, Hyuk Hee
(87) International Publication No	: NA	4)MYUNG, Jung Hwan
(61) Patent of Addition to Application Number	:NA	5)KYUN, Myung-Ok
Filing Date	:NA	6)JUNG, Jooyoung
(62) Divisional to Application Number	:NA	
Filing Date	:NA	

(57) Abstract :

ABSTRACT DIISOCYANATE COMPOSITION, PREPARATION METHOD THEREOF AND OPTICAL MATERIAL USING SAME The diisocyanate composition according to an embodiment of the present invention comprises, in the composition, a benzyl isocyanate having a methyl group in an amount of 5 ppm to 200 ppm, an aromatic compound having a halogen group in an amount of 5 ppm to 1,000 ppm, a benzyl isocyanate having an ethyl group in an amount of 1 ppm to 1,000 ppm, or a combination thereof. It is possible to improve the optical characteristics by preventing the occurrence of yellowing, striae, and cloudiness and to enhance the mechanical properties such as impact resistance at the same time. Thus, it can be advantageously used to prepare an optical material of high quality.

No. of Pages : 57 No. of Claims : 12

(12) PATENT APPLICATION PUBLICATION

(21) Application No.202014051487 A

(19) INDIA

(22) Date of filing of Application :26/11/2020

(43) Publication Date : 11/06/2021

(54) Title of the invention : METHOD OF PREPARING DIISOCYANATE COMPOSITION AND OPTICAL LENS •

(51) International classification	:C07C0263100000, G02B0001040000, C01C0001240000, C08G0018380000, C08G0073100000	(71)Name of Applicant : 1)SKC CO., LTD. Address of Applicant :84, Jangan-ro 309beon-gil, Jangan-gu, Suwon-si, Gyeonggi-do 16336, Republic of Korea Republic of Korea
(31) Priority Document No	:10-2019-0161540	2)WOORI FINE CHEM CO., LTD.
(32) Priority Date	:06/12/2019	(72)Name of Inventor :
(33) Name of priority country	:Republic of Korea	1)PAI, Jaeyoung
(86) International Application No	:NA	2)KIM, Jeongmoo
Filing Date	:NA	3)HAN, Hyuk Hee
(87) International Publication No	: NA	4)MYUNG, Jung Hwan
(61) Patent of Addition to Application Number	:NA	5)JUNG, Jooyoung
Filing Date	:NA	6)KYUN, Myung-Ok
(62) Divisional to Application Number	:NA	
Filing Date	:NA	

(57) Abstract :

Abstract METHOD OF PREPARING DIISOCYANATE COMPOSITION AND OPTICAL LENS • In the embodiments, an aqueous hydrochloric acid solution instead of hydrogen chloride gas and solid triphosgene instead of phosgene gas may be used in the process of preparing a diisocyanate from a diamine through a diamine hydrochloride. In addition, the embodiments provide processes for preparing a diisocyanate composition and an optical lens of higher quality by controlling the water content in the diamine hydrochloride composition for preparing a diisocyanate within a specific range.

No. of Pages : 41 No. of Claims : 10

(12) PATENT APPLICATION PUBLICATION

(21) Application No.202014051589 A

(19) INDIA

(22) Date of filing of Application :26/11/2020

(43) Publication Date : 11/06/2021

(54) Title of the invention : CLUSTER HEAD NOZZLE FOR SPRAYING A FLUID, ARRANGEMENT HAVING A CLUSTER HEAD NOZZLE AND METHOD FOR PRODUCING A CLUSTER HEAD NOZZLE

(51) International classification	:H04W0084180000, B60T0017000000, B29B0007800000, B29B0007740000, B33Y0080000000	(71) Name of Applicant : 1)Lechler GmbH Address of Applicant :Ulmer Strasse 128, 72555 Metzingen, Germany Germany
(31) Priority Document No	:10 2019 218 892.3	(72) Name of Inventor : 1)Thomas Zeeb
(32) Priority Date	:04/12/2019	
(33) Name of priority country	:Germany	
(86) International Application No	:NA	
Filing Date	:NA	
(87) International Publication No	: NA	
(61) Patent of Addition to Application Number	:NA	
Filing Date	:NA	
(62) Divisional to Application Number	:NA	
Filing Date	:NA	

(57) Abstract :

Abstract Cluster head nozzle for spraying a fluid, arrangement having a cluster head nozzle and method for producing a cluster head nozzle The invention relates to a cluster head nozzle for spraying a fluid, having a housing and having multiple outlet openings, which are arranged around a central region on a front side of the housing, for individual spray jets of at least one purge air outlet opening for purge air, in the case of which cluster head nozzle the at least one purge air outlet opening and at least sections of a feed channel for the purge air are provided in the single-piece housing. [Figure 4]

No. of Pages : 44 No. of Claims : 15

(12) PATENT APPLICATION PUBLICATION

(21) Application No.202014051600 A

(19) INDIA

(22) Date of filing of Application :26/11/2020

(43) Publication Date : 11/06/2021

(54) Title of the invention : HOLOGRAPHIC QUANTUM DYNAMICS SIMULATION

(51) International classification	:G06N0010000000, B82Y0010000000, H01L0029660000, H04N0019172000, H01L0023000000	(71) Name of Applicant : 1)HONEYWELL INTERNATIONAL INC. Address of Applicant :Intellectual Property Services Group 300 S. Tryon Street, Suite 600 Charlotte, North Carolina 28202, United States of America U.S.A.
(31) Priority Document No	:16/705,727	(72) Name of Inventor :
(32) Priority Date	:06/12/2019	1)MICHAEL FEIG
(33) Name of priority country	:U.S.A.	2)ANDREW C. POTTER
(86) International Application No	:NA	
Filing Date	:NA	
(87) International Publication No	: NA	
(61) Patent of Addition to Application Number	:NA	
Filing Date	:NA	
(62) Divisional to Application Number	:NA	
Filing Date	:NA	

(57) Abstract :

A quantum computer controller receives a quantum circuit comprising circuit slices. The first slice comprises a past causal cone of a first system qubit wire at a fully evolved level of the circuit. An i -th slice contains all gates that are within a past causal cone of a system qubit wire that reaches the fully evolved level in slice i that are not in the past causal cone of a system qubit wire that reaches the fully evolved level in slice $i-j$. The controller causes execution of the i -th slice using the physical qubits; causes a physical qubit that was evolved along a system qubit wire to the fully evolved level via execution of the i -th slice to be reinitialized and reintroduced onto a system qubit wire at a base level of the $i+m$ -th slice; and causes the quantum computer to use the physical qubit to execute the $i+m$ -th slice.

No. of Pages : 37 No. of Claims : 10

(12) PATENT APPLICATION PUBLICATION

(21) Application No.202014051603 A

(19) INDIA

(22) Date of filing of Application :26/11/2020

(43) Publication Date : 11/06/2021

(54) Title of the invention : DUST COVER FOR AN ELECTRICAL CONNECTOR IN AN ELECTRONIC CONTROL UNIT (ECU) ASSEMBLY

(51) International classification	:B01L0003000000, H01R0013520000, H01R0013740000, H02S0040340000, H01R0013518000	(71) Name of Applicant : 1)PERKINS ENGINES COMPANY LIMITED Address of Applicant :Frank Perkins Way Eastfield Peterborough, Cambridgeshire PE1 5FQ/GB, United Kingdom U.K.
(31) Priority Document No	:1917881.3	(72) Name of Inventor :
(32) Priority Date	:06/12/2019	1)CONSTANTINE, Martin G.
(33) Name of priority country	:U.K.	2)GRESSANI, Francis R.
(86) International Application No	:NA	3)ROBINSON, Brian
Filing Date	:NA	
(87) International Publication No	: NA	
(61) Patent of Addition to Application Number:	NA	
Filing Date	:NA	
(62) Divisional to Application Number	:NA	
Filing Date	:NA	

(57) Abstract :

An ECU assembly (100) includes one or more electrical connectors (20, 21) received in a protective cover (40). The cover (40) includes an introduction aperture (45) through which the connector or connectors can be introduced into the cover, and at least one connection aperture (44, 46) through which the or each connector is connected to the ECU. A retaining portion (50, 51) of the cover at each connection aperture (44, 46) is interposed between the respective connector (20, 21) and the ECU (1) to retain the cover (40) to the ECU (1) in its use position.

No. of Pages : 28 No. of Claims : 14

(12) PATENT APPLICATION PUBLICATION

(21) Application No.202014051757 A

(19) INDIA

(22) Date of filing of Application :27/11/2020

(43) Publication Date : 11/06/2021

(54) Title of the invention : METHOD FOR DETERMINING THE DETECTION THRESHOLD OF A RADAR SUITED TO A GIVEN ENVIRONMENT

(51) International classification	:G01S0007410000, G01S0007400000, G01S0013720000, G01S0007350000, G01S0013910000	(71) Name of Applicant : 1)THALES Address of Applicant :TOUR CARPE DIEM, Place des Corolles - Esplanade Nord - 92400 COURBEVOIE, FRANCE France
(31) Priority Document No	:1913836	(72) Name of Inventor :
(32) Priority Date	:06/12/2019	1)KEMKEMIAN, Stphane
(33) Name of priority country	:France	2)CORRETJA, Vincent
(86) International Application No	:NA	3)MACHHOUR, Sabrina
Filing Date	:NA	
(87) International Publication No	: NA	
(61) Patent of Addition to Application Number:	NA	
Filing Date	:NA	
(62) Divisional to Application Number	:NA	
Filing Date	:NA	

(57) Abstract :

The invention relates to a method for determining the detection threshold of a radar suited to a given environment, characterized in that it comprises at least: - a step (22) in which a set of statistical quantities characterizing said environment is selected; - a step (24) in which a set of functions is defined, each of said functions giving an intermediate detection threshold that is a function of statistical quantities taken from a subset of said set of statistical quantities; - a step (25) of combination of said intermediate detection thresholds, said detection threshold being the result of said combination. Figure for the abstract: Fig. 2

No. of Pages : 17 No. of Claims : 10

(12) PATENT APPLICATION PUBLICATION

(21) Application No.202014051836 A

(19) INDIA

(22) Date of filing of Application :27/11/2020

(43) Publication Date : 11/06/2021

(54) Title of the invention : AGENT MANAGEMENT DEVICE, PROGRAM, AND AGENT MANAGEMENT METHOD

(51) International classification	:H04L0012240000, H04Q0003000000, A61K0038550000, A61K0031715000, A61K0036185000	(71) Name of Applicant : 1)TOYOTA JIDOSHA KABUSHIKI KAISHA Address of Applicant :1, Toyota-cho, Toyota-shi, Aichi-ken, 471-8571, Japan Japan
(31) Priority Document No	:2019-222932	(72) Name of Inventor : 1)MAEDA, Eiichi
(32) Priority Date	:10/12/2019	
(33) Name of priority country	:Japan	
(86) International Application No	:NA	
Filing Date	:NA	
(87) International Publication No	: NA	
(61) Patent of Addition to Application Number	:NA	
Filing Date	:NA	
(62) Divisional to Application Number	:NA	
Filing Date	:NA	

(57) Abstract :

An agent management device includes a processor configured to: generate a response to an inquiry from an occupant of a moving body; determine whether or not a change in a control content of the moving body to correspond to the response is possible; output a question whether or not to execute the change to the control content to the occupant when determining that the change to the control content is possible; and execute the change to the control content when the occupant approves the change to the control content.

No. of Pages : 48 No. of Claims : 20

(12) PATENT APPLICATION PUBLICATION

(21) Application No.202014052044 A

(19) INDIA

(22) Date of filing of Application :30/11/2020

(43) Publication Date : 11/06/2021

(54) Title of the invention : INSTRUMENT FOR ELECTROSURGICAL TREATMENT

(51) International classification	:A61B0018000000, A61B0018140000, A61B0018040000, A61B0018120000, A61M0025000000	(71) Name of Applicant : 1)ERBE ELEKTROMEDIZIN GMBH Address of Applicant :Waldhoernlestrasse 17, 72072 Tuebingen, Germany Germany
(31) Priority Document No	:19213828.7	(72) Name of Inventor :
(32) Priority Date	:05/12/2019	1)KELLER Sandra
(33) Name of priority country	:EUROPEAN UNION	2)EDERER Michael
(86) International Application No	:NA	3)ENDERLE Markus
Filing Date	:NA	
(87) International Publication No	: NA	
(61) Patent of Addition to Application Number	:NA	
Filing Date	:NA	
(62) Divisional to Application Number	:NA	
Filing Date	:NA	

(57) Abstract :

The invention refers to an instrument for thermal treatment of tissue (34), particularly for electrosurgical treatment and particularly for argon plasma coagulation. The instrument has an instrument body (25) extending between a proximal end (27) and a distal end (28). In an end section (38) adjoining a distal end (28) the instrument body (25) comprises at least one color mark (39) in a defined color. This color corresponds to the color of a treated tissue (34) that is created, if the dosage of an energy introduction for achieving a desired depth effect in the tissue (34) has been selected correctly. Preferably the instrument is configured as probe (17), particularly as endoscope probe and has a flexible bendable instrument body (25) that can be referenced as instrument hose (26). (Figure 2)

No. of Pages : 29 No. of Claims : 15

(12) PATENT APPLICATION PUBLICATION

(21) Application No.202014052345 A

(19) INDIA

(22) Date of filing of Application :01/12/2020

(43) Publication Date : 11/06/2021

(54) Title of the invention : ELEVATOR GROUP MANAGEMENT SYSTEM

(51) International classification	:B66B0003000000, B66B0001240000, B66B0001180000, B66B0003020000, G06F0003120000	(71) Name of Applicant : 1)TOSHIBA ELEVATOR KABUSHIKI KAISHA Address of Applicant :72-34, Horikawa-cho, Saiwai-ku, Kawasaki-shi, Kanagawa 212-0013, Japan Japan
(31) Priority Document No	:2019-221390	(72) Name of Inventor : 1)Keiichi Nakanishi
(32) Priority Date	:06/12/2019	
(33) Name of priority country	:Japan	
(86) International Application No	:NA	
Filing Date	:NA	
(87) International Publication No	: NA	
(61) Patent of Addition to Application Number	:NA	
Filing Date	:NA	
(62) Divisional to Application Number	:NA	
Filing Date	:NA	

(57) Abstract :

ABSTRACT According to one embodiment, the elevator group management system, managing a plurality of cars, selecting an optimum car of the cars based on a passenger's destination floor registered by a hall destination controller installed on an arbitrary floor, and making the car respond to the registration floor as an allocated car, includes display control means holding allocation information indicative of a destination floor and an allocated car for each passenger performing a registration operation on the hall destination controller as history information, and displaying the history information on a part of a display unit provided in the hall destination controller.

No. of Pages : 39 No. of Claims : 11

(12) PATENT APPLICATION PUBLICATION

(21) Application No.202014052347 A

(19) INDIA

(22) Date of filing of Application :01/12/2020

(43) Publication Date : 11/06/2021

(54) Title of the invention : YARN HANDLING DEVICE

(51) International classification	:H04N0005232000, F16D0048020000, G01N0035080000, B65H0069060000, B65H0051160000	(71) Name of Applicant : 1)TMT Machinery, Inc. Address of Applicant :6th Fl., Osaka Green Bldg., 2-6-26 Kitahama, Chuo-ku, Osaka-shi, Osaka 541-0041, Japan Japan
(31) Priority Document No	:2019-222239	(72) Name of Inventor : 1)Yusuke RIYAMA
(32) Priority Date	:09/12/2019	
(33) Name of priority country	:Japan	
(86) International Application No	:NA	
Filing Date	:NA	
(87) International Publication No	: NA	
(61) Patent of Addition to Application Number	:NA	
Filing Date	:NA	
(62) Divisional to Application Number	:NA	
Filing Date	:NA	

(57) Abstract :

ABSTRACT OF THE DISCLOSURE YARN HANDLING DEVICE An object of the present invention is to provide a yarn handling device which is small in size and the state of which is switchable between a state in which a yarn is sucked and captured and a state in which the yarn is pinched and captured. A yarn handling device 7 includes a fluid supply passage 85 to which compressed air is supplied, a first capturing mechanism 81 which is able to suck and capture a yarn Y by means of the negative pressure generated when the compressed air is supplied to the fluid supply passage 85, and a second capturing mechanism 82 which is able to pinch and capture the yarn Y. The second capturing mechanism 82 is in a capturing state in which the yarn Y can be pinched and captured when the compressed air is not supplied to the fluid supply passage 85, whereas the second capturing mechanism 82 is switched from the capturing state into an unlocked state in which the yarn Y is not pinched when the compressed air is supplied to the fluid supply passage 85.

No. of Pages : 59 No. of Claims : 5

(12) PATENT APPLICATION PUBLICATION

(21) Application No.202014052350 A

(19) INDIA

(22) Date of filing of Application :01/12/2020

(43) Publication Date : 11/06/2021

(54) Title of the invention : ELEVATOR CONTROLLING APPARATUS AND ELEVATOR CONTROLLING METHOD

(51) International classification	:B66B0001240000, H04W0004020000, G06Q0010020000, G06Q0050300000, H04W0076100000	(71) Name of Applicant : 1)TOSHIBA ELEVATOR KABUSHIKI KAISHA Address of Applicant :72-34, Horikawa-cho, Saiwai-ku, Kawasaki-shi, Kanagawa, Japan Japan
(31) Priority Document No	:2019-221793	(72) Name of Inventor : 1)Yuki ARAI
(32) Priority Date	:09/12/2019	
(33) Name of priority country	:Japan	
(86) International Application No	:NA	
Filing Date	:NA	
(87) International Publication No	: NA	
(61) Patent of Addition to Application Number	:NA	
Filing Date	:NA	
(62) Divisional to Application Number	:NA	
Filing Date	:NA	

(57) Abstract :

operation mode in which no response is made to a hall call. ABSTRACT A left-behind passenger detector (503) detects a passenger who does not get into a car as a left-behind passenger upon the car arriving at floors. A first passenger car stay time measurer (505) measures a first passenger car stay time which is a stay time of a first passenger in the car. Upon a registration information of a first passenger car call being acquired, upon determination that the car is not full, upon detection of the left-behind passenger, and upon the first passenger car stay time exceeding a prescribed first determination time, an operation mode switcher (507A-507F) switches to and holds a first special operation mode until completion of a response to the first passenger car call, the first special operation mode in which no response is made to a hall call. [Selected Figure] Fig. 2

No. of Pages : 34 No. of Claims : 8

(12) PATENT APPLICATION PUBLICATION

(21) Application No.202014052353 A

(19) INDIA

(22) Date of filing of Application :01/12/2020

(43) Publication Date : 11/06/2021

(54) Title of the invention : NEURAL NETWORK PROCESSOR, CHIP AND ELECTRONIC DEVICE

(51) International classification	:G06N0003080000, G06N0003063000, G06N0003040000, H01F0017000000, G05D0023190000	(71) Name of Applicant : 1)GUANGDONG OPPO MOBILE TELECOMMUNICATIONS CORP., LTD. Address of Applicant :No.18, Haibin Road, Wusha, Chang'an, Dongguan, Guangdong 523860, China. China
(31) Priority Document No	:201911253027.0	(72) Name of Inventor :
(32) Priority Date	:09/12/2019	1)Shengguang YUAN
(33) Name of priority country	:China	
(86) International Application No	:NA	
Filing Date	:NA	
(87) International Publication No	: NA	
(61) Patent of Addition to Application Number	:NA	
Filing Date	:NA	
(62) Divisional to Application Number	:NA	
Filing Date	:NA	

(57) Abstract :

NEURAL NETWORK PROCESSOR, CHIP AND ELECTRONIC DEVICE The embodiments of the disclosure provide a neural network processor (200), a chip (20) and an electronic device (20). The neural network processor (200) includes a convolution processing unit (212), a vector processing unit (214), and an instruction issue module (220). The convolution processing unit (212) and the vector processing unit (214) are both connected to the instruction issue module (220). The instruction issue module (220) is configured to issue a plurality of instructions to the convolution processing unit (212) and the vector processing unit (214) in parallel. The embodiments of the application can improve the efficiency of the neural network processor (220) processing data

No. of Pages : 54 No. of Claims : 15

(54) Title of the invention : IMPROVED MEDICAL DEVICE FOR GLAUCOMA SURGERY WITH CONTROLLED AND MODULABLE FILTRATION

(51) International classification	:A61M0005310000, A61F0009007000, A61M0025000000, A61B0017160000, A61M0025010000	(71) Name of Applicant : 1)CECCHINI, Paolo Address of Applicant :Via Fabio Filzi, 21/1, I-34132 TRIESTE, ITALY Italy 2)ZOVATTO, Luigino
(31) Priority Document No	:IT 102019000023106	(72) Name of Inventor : 1)CECCHINI, Paolo 2)ZOVATTO, Luigino
(32) Priority Date	:05/12/2019	
(33) Name of priority country	:Italy	
(86) International Application No	:NA	
Filing Date	:NA	
(87) International Publication No	: NA	
(61) Patent of Addition to Application Number	:NA	
Filing Date	:NA	
(62) Divisional to Application Number	:NA	
Filing Date	:NA	

(57) Abstract :

ABSTRACT Title of the Invention:- IMPROVED MEDICAL DEVICE FOR GLAUCOMA SURGERY WITH CONTROLLED AND MODULABLE FILTRATION • A medical device for glaucoma surgery comprising a tubular body provided with a through cavity extending from a proximal end to a distal end, wherein at the proximal end the body comprises a first proximal positioning means of the device, wherein on the distal end side the tubular body comprises a second distal positioning means of the device. The tubular body comprises at least one proximal filtration hole, located on the side of the proximal end, and at least one distal filtration hole, located on the side of the distal end, said proximal and distal holes being fluidically connected to each other by means of said through cavity. The proximal and distal filtration holes are at least partially or completely occluded by a membrane made of resorbable material which can be removed at least partially by selective action, so as to allow the selective variation of the amount of aqueous humour flow removable via said through cavity. Figure: 1

No. of Pages : 39 No. of Claims : 17

(54) Title of the invention : SET OF ELECTRICAL PROTECTION DEVICES WITH TWO LEVELS THAT ARE CONNECTED IN SERIES

(51) International classification	:H01L0027120000, H02H0007260000, H01L0027020000, H01H0071240000, G01R0031500000	(71) Name of Applicant : 1)Schneider Electric Industries SAS Address of Applicant :35 rue Joseph Monier, 92500 Rueil Malmaison - FRANCE France
(31) Priority Document No	:1913809	(72) Name of Inventor :
(32) Priority Date	:05/12/2019	1)RIVAL Marc
(33) Name of priority country	:France	2)LISNYAK Marina
(86) International Application No	:NA	
Filing Date	:NA	
(87) International Publication No	: NA	
(61) Patent of Addition to Application Number	:NA	
Filing Date	:NA	
(62) Divisional to Application Number	:NA	
Filing Date	:NA	

(57) Abstract :

The present invention relates to a set of electrical protection devices with two levels that are connected in series, the first level including a circuit breaker that is referred to as the first or upstream circuit breaker and the second level including one or more circuit breakers referred to as second or downstream circuit breakers (8), which are 10 connected in parallel with respect to one another. This set is characterized in that the trip for the upstream circuit breaker (1), instead of including what are referred to as instantaneous protection means, includes, firstly, a first trip chain making it possible to adjust the long-delay trip curve for inverse time and the short-delay trip curve with a no-trip time and, secondly, a second trip chain 15 including an optical sensor (9) that is capable of discerning light between 300 and 450 nm by eliminating visible and infrared light so as to eliminate the light that is characteristic of gas jets emitted by the one or more circuit breakers referred to as downstream circuit breakers (8) during a switching operation, and means for simultaneously measuring the current level and the maximum threshold of light emitted 20 at the busbars, this second trip chain being capable of causing the upstream circuit breaker (1) to trip when the current exceeds a predetermined value and the light emitted exceeds a predetermined threshold for emitted light

No. of Pages : 21 No. of Claims : 10

(12) PATENT APPLICATION PUBLICATION

(21) Application No.202014052658 A

(19) INDIA

(22) Date of filing of Application :03/12/2020

(43) Publication Date : 11/06/2021

(54) Title of the invention : PRE-PROCESSING OF SUGAR CANE

(51) International classification	:A01D0045100000, C13B0010060000, H04N0019850000, A01C0011000000, C13B0020120000	(71) Name of Applicant : 1)Fitzmaurice, Alan Lewis Address of Applicant :c/- Intellepro, GPO Box 1339, Brisbane QLD 4001, Australia Australia
(31) Priority Document No	:2019904607	(72) Name of Inventor : 1)Fitzmaurice, Alan Lewis
(32) Priority Date	:05/12/2019	
(33) Name of priority country	:Australia	
(86) International Application No	:NA	
Filing Date	:NA	
(87) International Publication No	: NA	
(61) Patent of Addition to Application Number	:NA	
Filing Date	:NA	
(62) Divisional to Application Number	:NA	
Filing Date	:NA	

(57) Abstract :

A system 10 for infield collection of substantially whole cane and delivering that cane to a mill via a trash separator and a washer. A harvester 11 collects whole cane and throws billeted cane along with trash into an infield transporter 12 which then transports this to a centralised trash separator 13. The trash separator may service any number of infield transporters and may be located at a mill or at another centralised location so that output from the trash separator may pass on to a conveyor 14. Billets 15 are then fed to a washer 16. The washing liquid from downstream process may be used in the washer. This liquid enters the washer at 17. Mud and dirt is removed from the billets in return liquid at 18 which then passes to a mud removal unit 19 of conventional form. This juice is returned to the downstream process along line 20. It will be appreciated that since whole cane is being transported to a dedicated trash separator at 13 that there is very little loss in terms of juice carrying cane. The billets are moved on to the mill at 21. They will move to the first stage mill usually via a conveyor. Wash liquid may also be collected via an outlet conveyor from the washer. A modular harvester, a trash separator and a washer are also described.

No. of Pages : 34 No. of Claims : 26

(12) PATENT APPLICATION PUBLICATION

(21) Application No.202014052697 A

(19) INDIA

(22) Date of filing of Application :03/12/2020

(43) Publication Date : 11/06/2021

(54) Title of the invention : DISPLAY DEVICE

(51) International classification	:G06F0003041000, G02B0027010000, G09F0009300000, B60K0035000000, G09G0005000000	(71) Name of Applicant : 1)LG Display Co., Ltd Address of Applicant :128, Yeoui-daero, Yeongdeungpo-gu, Seoul, 07336, Republic of Korea Republic of Korea
(31) Priority Document No	:2019-219414	(72) Name of Inventor : 1)Ye, Jae-Hun
(32) Priority Date	:04/12/2019	
(33) Name of priority country	:Japan	
(86) International Application No	:NA	
Filing Date	:NA	
(87) International Publication No	: NA	
(61) Patent of Addition to Application Number	:NA	
Filing Date	:NA	
(62) Divisional to Application Number	:NA	
Filing Date	:NA	

(57) Abstract :

A display device (1) includes a piezoelectric element (10) vibrated according to input audio signals, a display panel (20) configured to display an image, and an elastic member (30) configured to connect a portion of the piezoelectric element (10) and the display panel (20) so as to transmit a vibration of the piezoelectric element (10) to the display panel (20) to improve sound quality in a display device (1) which emits a sound from a display panel (20).

No. of Pages : 36 No. of Claims : 33

(12) PATENT APPLICATION PUBLICATION

(21) Application No.202014052707 A

(19) INDIA

(22) Date of filing of Application :03/12/2020

(43) Publication Date : 11/06/2021

(54) Title of the invention : PORTABLE COMMUNICATION DEVICE INCLUDING DISPLAY

(51) International classification	:H04M0001725000, H04M0001020000, H01Q0001240000, H04M0001230000, H04M0001040000	(71) Name of Applicant : 1)SAMSUNG ELECTRONICS CO., LTD. Address of Applicant :129, Samsung-ro, Yeongtong-gu, Suwon-si, Gyeonggi-do 16677, Republic of Korea Republic of Korea
(31) Priority Document No	:10-2019-0160970	(72) Name of Inventor :
(32) Priority Date	:05/12/2019	1)Jeong WOO
(33) Name of priority country	:Republic of Korea	2)Jungchul AN
(86) International Application No	:NA	
Filing Date	:NA	
(87) International Publication No	: NA	
(61) Patent of Addition to Application Number	:NA	
Filing Date	:NA	
(62) Divisional to Application Number	:NA	
Filing Date	:NA	

(57) Abstract :

PORTABLE COMMUNICATION DEVICE INCLUDING DISPLAY A portable communication device includes: a foldable housing, a flexible display accommodated in the housing and including a first display area that remains substantially flat in a state in which the housing is folded and a second display area that is bendable as the housing is folded, a support located between the flexible display and the housing and including a first area corresponding to the first display area and having a first flexibility and a second area corresponding to the second display area and having a second flexibility greater than the first flexibility, wherein an opening is formed in the first area , and a sensing module accommodated in the housing and including a light receiving sensor at least partially aligned with the opening to sense light passing through the opening. FIG. 2

No. of Pages : 64 No. of Claims : 20

(12) PATENT APPLICATION PUBLICATION

(21) Application No.202014052830 A

(19) INDIA

(22) Date of filing of Application :04/12/2020

(43) Publication Date : 11/06/2021

(54) Title of the invention : SOUND SOURCE SIGNAL SEPARATOR AND MUSIC SYNC LOW FREQUENCY STIMULATOR COMPRISING THE SAME

(51) International classification	:A61N0001360000, H04R0003000000, G01V0001133000, H04N0019122000, A61H0023020000	(71) Name of Applicant : 1)CERAGEM Co., Ltd. Address of Applicant :10, Jeongja 1-gil, Seonggeo-eup, Seobuk-gu, Cheonan-si, Chungcheongnam-do 31045 Republic of Korea Republic of Korea
(31) Priority Document No	:10-2019-0161617	(72) Name of Inventor :
(32) Priority Date	:06/12/2019	1)Park, Yong son
(33) Name of priority country	:Republic of Korea	2)Lee, Dong Myoung
(86) International Application No	:NA	3)KIM, Yong Hee
Filing Date	:NA	4)HONG, Seung Gwan
(87) International Publication No	: NA	
(61) Patent of Addition to Application Number	:NA	
Filing Date	:NA	
(62) Divisional to Application Number	:NA	
Filing Date	:NA	

(57) Abstract :

SOUND SOURCE SIGNAL SEPARATOR AND MUSIC SYNC LOW FREQUENCY STIMULATOR COMPRISING THE SAME
The present invention provides a music sync low frequency stimulator including a speaker for outputting a plurality of first sound source signals, a sound source signal separator for separating at least one of the plurality of first sound source signals, a low frequency signal generator for generating a low frequency signal, and a music sync unit for controlling the strength and frequency of a low frequency signal according to at least one of second sound source signals separated by the sound source signal separator.

No. of Pages : 27 No. of Claims : 20

(12) PATENT APPLICATION PUBLICATION

(21) Application No.202014052998 A

(19) INDIA

(22) Date of filing of Application :04/12/2020

(43) Publication Date : 11/06/2021

(54) Title of the invention : ELECTRIC MACHINE CONTROL METHOD, ELECTRIC MACHINE CONTROL APPARATUS AND VEHICLE

(51) International classification	:D06F0033000000, H02P0025220000, H02K0009060000, B60K0001000000, H02P0027080000	(71) Name of Applicant : 1)BOSCH AUTOMOTIVE PRODUCTS (SUZHOU) CO. LTD. Address of Applicant :126 Su Hong Xi Road, Suzhou Industrial Park Suzhou, Jiangsu 215021, China China
(31) Priority Document No	:201911242564.5	(72) Name of Inventor :
(32) Priority Date	:06/12/2019	1)ZHAN, Kang
(33) Name of priority country	:China	
(86) International Application No	:NA	
Filing Date	:NA	
(87) International Publication No	: NA	
(61) Patent of Addition to Application Number:	NA	
Filing Date	:NA	
(62) Divisional to Application Number	:NA	
Filing Date	:NA	

(57) Abstract :

The present application provides an electric machine control method, an electric machine control apparatus and a vehicle. The electric machine control method is used for a vehicle driven by an electric machine, and comprises: acquiring a vehicle speed, a vehicle drive signal and a vehicle braking signal; if the vehicle speed is less than a predetermined value and the vehicle drive signal and the vehicle braking signal 10 are both present, commanding the electric machine to output a driving force according to the vehicle drive signal while the vehicle speed is less than the predetermined value. The electric machine control method, electric machine control apparatus and vehicle of the present application have advantages such as simplicity, reliability, ease of implementation, and smooth operation, and can offer an improved experience of 15 starting on a ramp.

No. of Pages : 17 No. of Claims : 10

(12) PATENT APPLICATION PUBLICATION

(21) Application No.202014053155 A

(19) INDIA

(22) Date of filing of Application :07/12/2020

(43) Publication Date : 11/06/2021

(54) Title of the invention : CONTROLLER

(51) International classification	:A61F0007000000, B65B0059020000, B24B0051000000, B02C0025000000, G05B0011280000	(71) Name of Applicant : 1)DENSO CORPORATION Address of Applicant :1-1, Showa-cho, Kariya-city, Aichi- pref., 448-8661 Japan Japan
(31) Priority Document No	:2019-221814	(72) Name of Inventor :
(32) Priority Date	:09/12/2019	1)SEKI, Naoto
(33) Name of priority country	:Japan	2)YAMADA, Naoyuki
(86) International Application No	:NA	3)Syed, Mohamed Mohamed Kuthbudeen
Filing Date	:NA	
(87) International Publication No	: NA	
(61) Patent of Addition to Application Number:	:NA	
Filing Date	:NA	
(62) Divisional to Application Number	:NA	
Filing Date	:NA	

(57) Abstract :

A vehicle (MV) includes a pump (130) configured to discharge a fuel by reciprocating a plunger (135), a rail (150) configured to store the fuel discharged from the pump, and a fuel injection valve (170) configured to inject the fuel supplied from the rail. A controller for the vehicle includes a waveform obtaining unit (11) and a phase shift obtaining unit (12). The waveform obtaining unit is configured to obtain a waveform of a fuel pressure in the rail as a function of time in a predetermined period. The phase shift obtaining unit (12) is configured to obtain a phase shift based on the waveform obtained by the waveform obtaining unit. The phase shift is an offset between a timing the plunger reciprocated in the pump arrives at a first position and a timing a piston reciprocating in an internal combustion engine arrives at a second position.

No. of Pages : 48 No. of Claims : 12

(12) PATENT APPLICATION PUBLICATION

(21) Application No.202014053205 A

(19) INDIA

(22) Date of filing of Application :07/12/2020

(43) Publication Date : 11/06/2021

(54) Title of the invention : GROUP CONTROL DEVICE FOR LIFTING DEVICES

(51) International classification	:A61G0007100000, B66B0001240000, B66C0001660000, B66C0013560000, B66C0001020000	(71) Name of Applicant : 1)TOSHIBA ELEVATOR KABUSHIKI KAISHA Address of Applicant :72-34, Horikawa-cho, Saiwai-ku, Kawasaki-shi, Kanagawa 212-0013, Japan Japan
(31) Priority Document No	:2019-222234	(72) Name of Inventor : 1)Masatomo NAKAGAWA
(32) Priority Date	:09/12/2019	
(33) Name of priority country	:Japan	
(86) International Application No	:NA	
Filing Date	:NA	
(87) International Publication No	: NA	
(61) Patent of Addition to Application Number	:NA	
Filing Date	:NA	
(62) Divisional to Application Number	:NA	
Filing Date	:NA	

(57) Abstract :

A group control device for lifting devices is disclosed. A decision unit decides a ranking for each combination of a zone and a lifting device, the zone being a group of a plurality of consecutive floors, the decision being performed based on a total number of 5 door openings and closings for each of a plurality of lifting devices per zone. An allocation unit allocates, based on the ranking, one or more of the lifting devices to one of the zones. A command unit transmits a command to set, as a standby floor of the one or more of the lifting devices, any of a plurality of floors included in the zone having been allocated to the one or more of the lifting devices, the command being transmitted to a 10 single unit control device that controls the one or more of the lifting devices.

No. of Pages : 56 No. of Claims : 6

(12) PATENT APPLICATION PUBLICATION

(21) Application No.202014053209 A

(19) INDIA

(22) Date of filing of Application :07/12/2020

(43) Publication Date : 11/06/2021

(54) Title of the invention : SYSTEMS AND METHODS FOR AUTOMATED TRADING

(51) International classification	:G06Q0040060000, G06Q0040000000, G06Q0040040000, G06N0003080000, G06N0003040000	(71) Name of Applicant : 1)UST Global Inc. Address of Applicant :5 Polaris Way, Aliso Viejo, California 92656 (US) U.S.A. 2)UST Global (Singapore) Pte. Ltd.
(31) Priority Document No	:201911050190	(72) Name of Inventor :
(32) Priority Date	:05/12/2019	1)THOMAS, Kurien Cherian
(33) Name of priority country	:India	
(86) International Application No	:NA	
Filing Date	:NA	
(87) International Publication No	: NA	
(61) Patent of Addition to Application Number	:NA	
Filing Date	:NA	
(62) Divisional to Application Number	:NA	
Filing Date	:NA	

(57) Abstract :

A system configured to: (a) retrieve structured and unstructured data from one or more external data sources, the structured data including time-series data on a financial instrument and the unstructured data including words; (b) analyze the unstructured data to determine a sentiment measure for the financial instrument; (c) analyze the structured data to obtain a training dataset; (d) train a neural network model with the training dataset such that the neural network can provide a predicted price of the financial instrument for a future timestamp; and (e) provide a decision for managing the financial instrument based at least in part on the sentiment measure for the financial instrument, the predicted price of the financial instrument, and a current holding of the financial instrument.

No. of Pages : 35 No. of Claims : 14

(12) PATENT APPLICATION PUBLICATION

(21) Application No.202014053212 A

(19) INDIA

(22) Date of filing of Application :07/12/2020

(43) Publication Date : 11/06/2021

(54) Title of the invention : HELICOPTER ROTOR MECHANICAL BRAKING SYSTEM

(51) International classification	:F16D0055000000, B62L0003020000, F16D0121140000, F16D0049160000, B60L0007260000	(71)Name of Applicant : 1)Joint Stock Company «National helicopter center Mil & Kamov» Address of Applicant :26/1 Garshin street, Tomilino work settlement, Lyubertsy, Moscow region, 140070, Russian Federation Russia
(31) Priority Document No	:2019139975	(72)Name of Inventor :
(32) Priority Date	:06/12/2019	1)KALININ, Yaroslav Vladimirovich
(33) Name of priority country	:Russia	2)NIKONCHUK, Natalya Vik torovna
(86) International Application No	:NA	3)PLUSHCHEVSKIY, Alexey Mikhailovich
Filing Date	:NA	4)FOMIN, Artem Alexandrovich
(87) International Publication No	: NA	
(61) Patent of Addition to Application Number:	NA	
Filing Date	:NA	
(62) Divisional to Application Number	:NA	
Filing Date	:NA	

(57) Abstract :

The mechanical braking system of the helicopter rotors contains a brake control lever, a brake cover, a brake drum, a caliper, two brake shoes, a brake lever, a roller connected to the brake lever and kinematically connected to the brake shoes, a micro-switch and wiring connecting the brake control lever to the brake lever. Mechanical braking system the rotors of a helicopter fitted with bracket with micro-switch, mounted on the lid of the brake, a roller mounted on the caliper, the caliper is provided with a tappet with a return spring, the brake cover is made with the axle and grooves in the roller and the pusher, the caliper is made with the possibility of rotation of the axle in conjunction with the brake drum when you grip it with the brake shoes, the wiring associated with the brake lever via a spring-loaded tip, and the brake control lever is made with the possibility of fixing it on the control panel when the brake shoes are engaged with the brake drum. The technical result is to increase the reliability of the helicopter operation and the safety of using the braking devices of the helicopter rotor drive system in the event of unforeseen situations before takeoff, in flight and after landing.

No. of Pages : 21 No. of Claims : 4

(12) PATENT APPLICATION PUBLICATION

(21) Application No.202014053469 A

(19) INDIA

(22) Date of filing of Application :08/12/2020

(43) Publication Date : 11/06/2021

(54) Title of the invention : BATTERY CELL MODULE FOR A BATTERY AND METHOD FOR PRODUCING BATTERY CELL MODULE

(51) International classification	:H01M0002100000, H01M0002020000, H01M0010040000, H01M0002200000, H01M0010613000	(71) Name of Applicant : 1)ROBERT BOSCH GMBH Address of Applicant :Postfach 30 02 20, 70442 Stuttgart, Germany Germany
(31) Priority Document No	:102019219258.0	(72) Name of Inventor :
(32) Priority Date	:10/12/2019	1)MEINCKE, Georg
(33) Name of priority country	:Germany	2)FOMEN, Gilles Desmond
(86) International Application No	:NA	3)LOGES, Iryna
Filing Date	:NA	4)MAENNER, Manuel
(87) International Publication No	: NA	5)SCHIEFER, Peter
(61) Patent of Addition to Application Number	:NA	
Filing Date	:NA	
(62) Divisional to Application Number	:NA	
Filing Date	:NA	

(57) Abstract :

BATTERY CELL MODULE FOR A BATTERY AND METHOD FOR PRODUCING BATTERY CELL MODULE The present subject matter relates to a battery cell module (1) for a battery, 5 comprises a module base body (2) with a plurality of receiving cavities (3), wherein a battery cell (4) of the battery cell module (1) is arranged in each of the receiving cavities (3), an electrical coupling device (5) comprises a plurality of electrical conductors (6), wherein the battery cells (4) are electrically coupled to one another via the electrical conductors (6), as well as a cooling device (7) for cooling the battery cells (4), wherein 10 the cooling device (7) is arranged on a first base body side (8) of the module base body (2). A deformable heat conducting medium (9) is arranged between the cooling device (7) and the battery cells (4) such that the battery cells (4) are thermally coupled to the cooling device (7) via the heat conducting medium (9).

No. of Pages : 23 No. of Claims : 10

(12) PATENT APPLICATION PUBLICATION

(21) Application No.202014054609 A

(19) INDIA

(22) Date of filing of Application :15/12/2020

(43) Publication Date : 11/06/2021

(54) Title of the invention : APPARATUS AND METHOD FOR PULSE CYCLE PRESSURE MODULATION AND VARIABLE PRESSURE THERAPY

(51) International classification	:A61H0009000000, A61B0005021000, A61K0045060000, A61B0005026000, A61B0005145500	(71) Name of Applicant : 1)SYNCARDON LLC Address of Applicant :110, Ceton CT, Broomall, Pennsylvania, 19008 USA U.S.A.
(31) Priority Document No	:GC 2019-38780	(72) Name of Inventor :
(32) Priority Date	:04/12/2019	1)VIKAS KHURANA
(33) Name of priority country	:U.S.A.	2)JOEL STEINBERG
(86) International Application No	:NA	
Filing Date	:NA	
(87) International Publication No	: NA	
(61) Patent of Addition to Application Number	:NA	
Filing Date	:NA	
(62) Divisional to Application Number	:NA	
Filing Date	:NA	

(57) Abstract :

The present invention relates to an apparatus for pulse cycle pressure modulation and variable pressure therapy in a cardio synchronous manner to improve blood flow. The invention applies a combination of positive pressure to a portion of the body and negative or variable pressure to a portion of the body. In particular, the invention uses a sequential and gradient pulse wave for treating wounds that are difficult to heal or livelihood limiting claudication and/or ischemic rest pain. The invention also comprises integrated methods to determine blood flow and effects of treatments on tissue.

No. of Pages : 44 No. of Claims : 21

(12) PATENT APPLICATION PUBLICATION

(21) Application No.202017008408 A

(19) INDIA

(22) Date of filing of Application :27/02/2020

(43) Publication Date : 11/06/2021

(54) Title of the invention : NASAL APPARATUS AND METHOD OF DRUG DELIVERY USING SAID NASAL APPARATUS

(51) International classification	:A61F 5/08, A61M 29/00, A62B 23/06	(71)Name of Applicant :
(31) Priority Document No	:201811031808	1)NASAL MEDICAL LIMITED
(32) Priority Date	:24/08/2018	Address of Applicant :Guinness Enterprise Centre Taylor's Lane Dublin, 8 Ireland
(33) Name of priority country	:India	(72)Name of Inventor :
(86) International Application No	:PCT/EP2019/072644	1)O'CONNELL, Martin
Filing Date	:23/08/2019	2)YEAGER, Keith
(87) International Publication No	:WO 2020/039095	
(61) Patent of Addition to Application Number	:NA	
Filing Date	:NA	
(62) Divisional to Application Number	:NA	
Filing Date	:NA	

(57) Abstract :

The present invention relates to a nasal apparatus which improves respiration by expanding the nasal airways and preferably, the apparatus comprises a filter to block irritating or harmful particles. The apparatus of the present invention is preferably, configured to retain the filter on the apparatus while providing comfort for the user to wear the apparatus. In another aspect of the present invention, the invention also relates to a method of delivering a therapy intradermally or intramucosally including a therapy such as a medicament including drug delivery, delivery of essential oils or any desirable therapy that can be delivered intradermally or intramucosally through the nasal mucous membranes.



No. of Pages : 26 No. of Claims : 28

(12) PATENT APPLICATION PUBLICATION

(21) Application No.202017024019 A

(19) INDIA

(22) Date of filing of Application :08/06/2020

(43) Publication Date : 11/06/2021

(54) Title of the invention : TRANSFORM SELECTION IN A VIDEO ENCODER AND/OR VIDEO DECODER

(51) International classification	:H04N 19/12, H04N 19/159, H04N 19/186, H04N 19/176, H04N 19/61	(71) Name of Applicant : 1)TELEFONAKTIEBOLAGET LM ERICSSON (PUBL) Address of Applicant :SE-164 83 Stockholm Sweden
(31) Priority Document No	:62/697484	(72) Name of Inventor :
(32) Priority Date	:13/07/2018	1)YU, Ruoyang
(33) Name of priority country	:U.S.A.	2)ZHANG, Zhi
(86) International Application No	:PCT/EP2019/068548	3)SJ-BERG, Rickard
Filing Date	:10/07/2019	
(87) International Publication No	:WO 2020/011860	
(61) Patent of Addition to Application Number	:NA	
Filing Date	:NA	
(62) Divisional to Application Number	:NA	
Filing Date	:NA	

(57) Abstract :

A process for selecting a transform set for a prediction block. The process can be used in both an encoder and a decoder. For example, the process can be used in both an encoder and a decoder for a prediction block that has been predicted from a reference block. In some embodiments, both the prediction block and the reference block are intra blocks.

No. of Pages : 20 No. of Claims : 23

(12) PATENT APPLICATION PUBLICATION

(21) Application No.202017024151 A

(19) INDIA

(22) Date of filing of Application :09/06/2020

(43) Publication Date : 11/06/2021

(54) Title of the invention : INSULATING GLAZING UNIT

(51) International classification :E06B 3/66
(31) Priority Document No :18172066.5
(32) Priority Date :14/05/2018
(33) Name of priority country :EPO
(86) International Application No :PCT/EP2019/061758
Filing Date :08/05/2019
(87) International Publication No :WO 2019/219461
(61) Patent of Addition to Application Number :NA
Filing Date :NA
(62) Divisional to Application Number :NA
Filing Date :NA

(71)**Name of Applicant :**
1)SAINT-GOBAIN GLASS FRANCE
Address of Applicant :12 Place de l'Iris Tour Saint-Gobain
92400 Courbevoie France
(72)**Name of Inventor :**
1)HOLTSTIEGE, Thomas
2)DR-GE, Alicia
3)EFFERTZ, Christian
4)MARJAN, Christopher

(57) Abstract :

The invention relates to an insulating glazing unit (1), comprising at least two glass panes (4a, 4b) and a spacer profile (5) arranged between same and running around close to the edges thereof, for use in a window (2), a door or a facade glazing (10), which has a respective frame (3) engaging around the edges of the insulating glazing, in particular a metal frame, wherein at least one RFID transponder (9, 9a-9d) is attached to the insulating glazing unit as an identification element, characterised in that the/at least one transponder is arranged on an inner surface of one of the glass panes in a spacing range between the spacer profile and the edge of the glass pane.

No. of Pages : 8 No. of Claims : 8

(12) PATENT APPLICATION PUBLICATION

(21) Application No.202017024177 A

(19) INDIA

(22) Date of filing of Application :09/06/2020

(43) Publication Date : 11/06/2021

(54) Title of the invention : METHOD FOR DECODING IMAGE ON BASIS OF CCLM PREDICTION IN IMAGE CODING SYSTEM, AND DEVICE THEREFOR

(51) International classification	:H04N 19/11, H04N 19/593, H04N 19/132, H04N 19/186, H04N 19/70	(71) Name of Applicant : 1)LG ELECTRONICS INC. Address of Applicant :128, Yeoui-daero, Yeongdeungpo-gu Seoul 07336 Republic of Korea
(31) Priority Document No	:62/770835	(72) Name of Inventor :
(32) Priority Date	:23/11/2018	1)CHOI, Jangwon
(33) Name of priority country	:U.S.A.	2)HEO, Jin
(86) International Application No	:PCT/KR2019/015253	3)KIM, Seunghwan
Filing Date	:11/11/2019	4)YOO, Sunmi
(87) International Publication No	:WO 2020/105925	5)LI, Ling
(61) Patent of Addition to Application Number	:NA	6)CHOI, Jungah
Filing Date	:NA	
(62) Divisional to Application Number	:NA	
Filing Date	:NA	

(57) Abstract :

A video decoding method performed by a decoding apparatus according to the 5 present disclosure includes deriving one of a plurality of cross-component linear model (CCLM) prediction mode as a CCLM prediction mode of the current chroma block, deriving a sample number of neighboring chroma samples of the current chroma block based on the CCLM prediction mode of the current chroma block, a size of the current chroma block, and a specific value; deriving the neighboring chroma samples of the 10 sample number, calculating CCLM parameters based on the neighboring chroma samples and the down sampled neighboring luma samples, deriving prediction samples for the current chroma block based on the CCLM parameters and the down sampled luma samples and generating reconstructed samples for the current chroma block based on the prediction samples, wherein the specific value is derived as 2.

No. of Pages : 140 No. of Claims : 15

(12) PATENT APPLICATION PUBLICATION

(21) Application No.202017024647 A

(19) INDIA

(22) Date of filing of Application :11/06/2020

(43) Publication Date : 11/06/2021

(54) Title of the invention : SAFETY-ENHANCED CAN LID

(51) International classification :B65D 17/28
(31) Priority Document No :10-2018-0083998
(32) Priority Date :19/07/2018
(33) Name of priority country :Republic of Korea
(86) International Application No :PCT/KR2019/008339
Filing Date :08/07/2019
(87) International Publication No :WO 2020/017802
(61) Patent of Addition to Application Number :NA
Filing Date :NA
(62) Divisional to Application Number :NA
Filing Date :NA

(71)Name of Applicant :

1)SON, Kijung

Address of Applicant :304Ho, 5-2, Hyeonggokdong-ro 2-gil
Gumi-si Gyeongsangbuk-do 39320 Republic of Korea

(72)Name of Inventor :

1)SON, Kijung

(57) Abstract :

The present invention relates a safety-enhanced can lid and, more particularly, to a safety-enhanced can lid which is provided with a prevention part for preventing a user's hand from being cut by the boundary of the lid, coupled to a can so as to seal same, and thereby allows safe use. To this end, the can lid which is coupled to the top of a container having contents stored therein, according to the present invention, comprises: a flat plate which is installed so as to cover the top of the container and has a can tab provided on the top surface thereof; and a hand cut prevention part comprising a cut prevention wall which is bent downwards from the boundary of the plate towards the side of the container.

No. of Pages : 14 No. of Claims : 4

(12) PATENT APPLICATION PUBLICATION

(21) Application No.202017025060 A

(19) INDIA

(22) Date of filing of Application :15/06/2020

(43) Publication Date : 11/06/2021

(54) Title of the invention : CYCLOHEXENE PROPANAL DERIVATIVES AS PERFUMING INGREDIENTS

(51) International classification	:C11B 9/00, A61K 8/35, A61Q 13/00, C07C 47/225, C11D 3/50	(71) Name of Applicant : 1)FIRMENICH SA Address of Applicant :1, route des Jeunes PO Box 239 1211 GENEVA 8 Switzerland
(31) Priority Document No	:18178947.0	(72) Name of Inventor :
(32) Priority Date	:21/06/2018	1)QUINTAINE, Julie
(33) Name of priority country	:EPO	2)MORETTI, Robert
(86) International Application No	:PCT/EP2019/066362	
Filing Date	:20/06/2019	
(87) International Publication No	:WO 2019/243506	
(61) Patent of Addition to Application Number	:NA	
Filing Date	:NA	
(62) Divisional to Application Number	:NA	
Filing Date	:NA	

(57) Abstract :

The present invention concerns a compound of formula (I) in the form of any one of its stereoisomers or a mixture thereof, and wherein R1, R2, R3 and R4 independently from each other, represent a hydrogen atom or a C1-2 alkyl group. The use of compound of formula (I) as perfuming ingredients of floral type and the invention's compounds as part of a perfuming composition or of a perfuming consumer product are also part of the present invention.

No. of Pages : 31 No. of Claims : 13

(12) PATENT APPLICATION PUBLICATION

(21) Application No.202017025688 A

(19) INDIA

(22) Date of filing of Application :18/06/2020

(43) Publication Date : 11/06/2021

(54) Title of the invention : VANILLA COMPOSITION

(51) International classification	:A23L 27/00, A23L 27/10, A23L 27/20	(71) Name of Applicant : 1)FIRMENICH SA
(31) Priority Document No	:PCT/CN2018/108581	Address of Applicant :1, route des Jeunes PO Box 239 1211
(32) Priority Date	:29/09/2018	GENEVA 8 Switzerland
(33) Name of priority country	:China	(72) Name of Inventor :
(86) International Application No	:PCT/EP2019/076477	1)BILLAT-ROSSI, Maryline
Filing Date	:30/09/2019	2)SALORD, Patrick
(87) International Publication No	:WO 2020/065097	3)SHEN, Echo, Hong
(61) Patent of Addition to Application Number	:NA	4)YUAN, Yong, Ming
Filing Date	:NA	
(62) Divisional to Application Number	:NA	
Filing Date	:NA	

(57) Abstract :

The present invention relates to a composition for conferring, enhancing or imparting a vanilla note comprising 2-hydroxy-4-methoxybenzaldehyde and vanillin imparted compound selected from the group of 3-ethoxy-4-hydroxybenzaldehyde or 4-hydroxy-3-ethoxybenzaldehyde and to a perfumed or flavored consumer product comprising the invention's composition. Moreover, the present invention concerns an extract comprising at least 10 % of 2-hydroxy-4-methoxybenzaldehyde and a method to improve, enhance or modify the vanilla flavour profile of a composition using said extract.

No. of Pages : 34 No. of Claims : 21

(12) PATENT APPLICATION PUBLICATION

(21) Application No.202017025774 A

(19) INDIA

(22) Date of filing of Application :18/06/2020

(43) Publication Date : 11/06/2021

(54) Title of the invention : ENERGY ABSORBING DEVICE ADAPTED FOR A MILD IMPACT OF AN AIRCRAFT,UAV,EQUIPPED WITH A PARACHUTE

(51) International classification	:B64D 17/34, B64D 17/36, B64D 17/54, B64D 17/80
(31) Priority Document No	:20180100506
(32) Priority Date	:02/11/2018
(33) Name of priority country	:Greece
(86) International Application No	:PCT/GR2019/000068
Filing Date	:10/10/2019
(87) International Publication No	:WO 2020/089660
(61) Patent of Addition to Application Number	:NA
Filing Date	:NA
(62) Divisional to Application Number	:NA
Filing Date	:NA

(71)Name of Applicant :

1)GIANNAKOPOULOS, Pavlos

Address of Applicant :Mezonos & Zaimi Str. P.O.Box 3075

26 001 Patra Greece

(72)Name of Inventor :

1)GIANNAKOPOULOS, Pavlos

(57) Abstract :

An energy absorbing device provided at the parachute riser strap of an aircraft, UAV, etc., adapted to reduce the otherwise high forces resulting from the weight of the aircraft, the speed of descent and, ultimately, the speed of impact, activated by the pilot or by means of the photoelectric cell attached underneath the aircraft measuring the distance from the ground.

No. of Pages : 14 No. of Claims : 7

(54) Title of the invention : METHOD FOR PREPARING VINYL CYAN COMPOUND-CONJUGATED DIENE COMPOUND-AROMATIC VINYL COMPOUND GRAFT COPOLYMER AND THERMOPLASTIC RESIN COMPOSITION COMPRISING GRAFT COPOLYMER

(51) International classification	:C08F 279/02, C08F 6/18	(71) Name of Applicant : 1)LG CHEM, LTD. Address of Applicant :128, Yeoui-daero Yeongdeungpo-gu Seoul 07336 Republic of Korea
(31) Priority Document No	:10-2018-0161808	(72) Name of Inventor :
(32) Priority Date	:14/12/2018	1)SUK, Jae Min
(33) Name of priority country	:Republic of Korea	2)KIM, Yoo Vin
(86) International Application No	:PCT/KR2019/013802	3)KIM, Young Min
Filing Date	:21/10/2019	4)LEE, Jin Hyoung
(87) International Publication No	:WO 2020/122407	5)HAN, Sujeong
(61) Patent of Addition to Application Number	:NA	6)JEONG, Young Hwan
Filing Date	:NA	7)PARK, Changhong
(62) Divisional to Application Number	:NA	8)HEO, Jaewon
Filing Date	:NA	

(57) Abstract :

The present invention relates to a method of preparing a graft copolymer and a thermoplastic resin composition including the graft copolymer. More specifically, the present invention relates to a method of preparing a graft copolymer, the method including a step of performing coagulation by adding an acid coagulant to 100 parts by weight (based on solids) of graft copolymer latex prepared by graft-polymerizing an aromatic vinyl compound and a vinyl 10 cyanide compound onto conjugated diene rubber latex; and a step of performing coagulation once more by adding a salt coagulant thereto. According to the present invention, when the method is used to prepare a graft copolymer, coagulation efficiency may be improved and the gloss of the prepared graft copolymer may be increased. In addition, since a b-value measured using a Hunter lab colorimeter and a b-value measured after being left at 250 °C for 15 minutes are low, the graft copolymer may have excellent color characteristics. In addition, since heating loss is low and 57 scorch time is long, the graft copolymer may have excellent processing characteristics.

No. of Pages : 50 No. of Claims : 13

(12) PATENT APPLICATION PUBLICATION

(21) Application No.202017026255 A

(19) INDIA

(22) Date of filing of Application :22/06/2020

(43) Publication Date : 11/06/2021

(54) Title of the invention : HIGH-ALUMINA MELT-CASTED REFRACTORY AND METHOD FOR MANUFACTURING SAME

(51) International classification	:C04B 35/107, C03B 5/43, F27D 1/00	(71)Name of Applicant :
(31) Priority Document No	:2019-036722	1)SAINT-GOBAIN TM K.K.
(32) Priority Date	:28/02/2019	Address of Applicant :3-7 Kojimachi, Chiyoda-ku, Tokyo
(33) Name of priority country	:Japan	1020083 Japan
(86) International Application No	:PCT/JP2019/031871	(72)Name of Inventor :
Filing Date	:13/08/2019	1)ABE, Koya
(87) International Publication No	:WO 2020/174719	2)SUGIYAMA, Hiroshi
(61) Patent of Addition to Application Number	:NA	3)TSUCHIYA, Shinji
Filing Date	:NA	4)HASHIMOTO, Itaru
(62) Divisional to Application Number	:NA	5)MISU, Yasuo
Filing Date	:NA	

(57) Abstract :

The present invention provides: a high-alumina casted refractory which can be manufactured easily and has a small porosity and high corrosion resistance; and a method for manufacturing the high-alumina casted refractory. The high-alumina casted refractory according to the present invention has the following chemical composition: 95.0 to 99.5% by mass of Al₂O₃, 0.20 to 1.50% by mass of SiO₂, 0.05 to 1.50% by mass of B₂O₃, 0.05 to 1.20% by mass of MgO, and a remainder. The method for manufacturing a high-alumina casted refractory according to the present invention comprises: mixing an Al₂O₃ raw material, an SiO₂ raw material, a B₂O₃ raw material and an MgO raw material together to produce a mixture; and melting the mixture.

No. of Pages : 15 No. of Claims : 10

(12) PATENT APPLICATION PUBLICATION

(21) Application No.202017026258 A

(19) INDIA

(22) Date of filing of Application :22/06/2020

(43) Publication Date : 11/06/2021

(54) Title of the invention : METHOD FOR PRODUCING TRIFLUOROMETHYL THIOALKYL COMPOUND, AND COMPOSITION OF TRIFLUOROMETHYL THIOALKYL HALIDE COMPOUND

(51) International classification	:C07C 319/14, C07C 323/03	(71) Name of Applicant : 1)KUMIAI CHEMICAL INDUSTRY CO., LTD. Address of Applicant :4-26, Ikenohata 1-chome, Taito-ku, Tokyo 1108782 Japan
(31) Priority Document No	:2018-084522	
(32) Priority Date	:25/04/2018	
(33) Name of priority country	:Japan	(72) Name of Inventor :
(86) International Application No	:PCT/JP2019/016449	1)YASUMURA Shingo
Filing Date	:17/04/2019	
(87) International Publication No	:WO 2019/208355	
(61) Patent of Addition to Application Number	:NA	
Filing Date	:NA	
(62) Divisional to Application Number	:NA	
Filing Date	:NA	

(57) Abstract :

A method for producing a trifluoromethyl thioalkyl halide compound represented by formula (1) (wherein X1 represents a halogen atom selected from the group consisting of a fluorine atom, a chlorine atom, a bromine atom and an iodine atom; and n represents an integer of 1 to 10), the method being characterized by comprising adding thiophosgene while heating at 45°C or higher in the presence of a dihalogenated alkyl compound represented by formula (2) (wherein X2 represents a halogen atom selected from the group consisting of a fluorine atom, a chlorine atom, a bromine atom and an iodine atom; and X1 and n are as defined above) and a fluorine compound.

No. of Pages : 51 No. of Claims : 11

(12) PATENT APPLICATION PUBLICATION

(21) Application No.202017026440 A

(19) INDIA

(22) Date of filing of Application :23/06/2020

(43) Publication Date : 11/06/2021

(54) Title of the invention : CAMP RECEPTOR PROTEIN MUTANT AND METHOD FOR PREPARING L-AMINO ACID BY USING SAME

(51) International classification	:C07K 14/195, C12N 15/70, C12P 13/04, C12P 13/08, C12P 13/22	(71)Name of Applicant : 1)CJ CHEILJEDANG CORPORATION Address of Applicant :330, Dongho-ro, Jung-gu, Seoul 04560 Republic of Korea
(31) Priority Document No	:10-2018-0151043	(72)Name of Inventor :
(32) Priority Date	:29/11/2018	1)LEE, Seok Myung
(33) Name of priority country	:Republic of Korea	2)CHEONG, Ki Yong
(86) International Application No	:PCT/KR2019/009292	3)SEO, Chang Il
Filing Date	:25/07/2019	4)LEE, Ji Sun
(87) International Publication No	:WO 2020/111437	
(61) Patent of Addition to Application Number	:NA	
Filing Date	:NA	
(62) Divisional to Application Number	:NA	
Filing Date	:NA	

(57) Abstract :

The present application relates to a CAMP receptor protein mutant, a microorganism comprising same, and a method for preparing L-amino acid by using same.

No. of Pages : 30 No. of Claims : 11

(12) PATENT APPLICATION PUBLICATION

(21) Application No.202017026909 A

(19) INDIA

(22) Date of filing of Application :25/06/2020

(43) Publication Date : 11/06/2021

(54) Title of the invention : FIRE GRATE

(51) International classification	:F23H 3/02, F23H 7/14	(71)Name of Applicant :
(31) Priority Document No	:2018-004543U	1)MITSUBISHI HEAVY INDUSTRIES
(32) Priority Date	:22/11/2018	ENVIRONMENTAL & CHEMICAL ENGINEERING CO., LTD.
(33) Name of priority country	:Japan	Address of Applicant :4-2, Minatomirai 4-chome, Nishi-ku,
(86) International Application No	:PCT/JP2019/026978	Yokohama-shi, Kanagawa 2200012 Japan
Filing Date	:08/07/2019	(72)Name of Inventor :
(87) International Publication No	:WO 2020/105217	1)ODAKA Shigeki
(61) Patent of Addition to Application Number	:NA	2)NAKAHARAI Hiroyuki
Filing Date	:NA	3)ODANO Takahiro
(62) Divisional to Application Number	:NA	4)MATSUDA Hiroki
Filing Date	:NA	5)NAGAHARA Shunichi

(57) Abstract :

Provided is a fire grate (1) having: an upper wall (2) that extends in a first direction (D); a front wall (3) that extends downward from a tip of the upper wall (2); a flow passage (S) that is provided on the backside of the upper wall (2); and a partition wall (8) that vertically partitions the flow passage (S), and that has a partition wall body (9) having a main surface facing the upper wall (2) and having a plurality of cooling holes (10) formed in the partition wall body (9) for impingement-cooling the upper wall (2) by allowing a cooling refrigerant to be jetted therethrough toward the backside of the upper wall 2.

No. of Pages : 28 No. of Claims : 10

(12) PATENT APPLICATION PUBLICATION

(21) Application No.202017026923 A

(19) INDIA

(22) Date of filing of Application :25/06/2020

(43) Publication Date : 11/06/2021

(54) Title of the invention : FINGERPRINT REGISTRATION METHOD AND ELECTRONIC DEVICE USING THE SAME

(51) International classification :G06K 9/00
(31) Priority Document No :62/656367
(32) Priority Date :12/04/2018
(33) Name of priority country :U.S.A.
(86) International Application No :PCT/CN2019/082121
Filing Date :10/04/2019
(87) International Publication No :WO 2019/196882
(61) Patent of Addition to Application Number :NA
Filing Date :NA
(62) Divisional to Application Number :NA
Filing Date :NA

(71)**Name of Applicant :**
1)EGIS TECHNOLOGY INC.
Address of Applicant :2F, No. 360, Rueiguang Rd., Neihu District, Taipei, Taiwan 11492 China
(72)**Name of Inventor :**
1)CHIANG, Yuan-Lin
2)FAN, Yuan-Chang

(57) Abstract :

A fingerprint registration method and an electronic device using the same are provided. The fingerprint registration method includes the following steps: sequentially obtaining a plurality of swipe frames of a fingerprint by a fingerprint sensor; sequentially analyzing the swipe frames by a processor to obtain a plurality of feature points; sequentially merging the feature points of the swipe frames into pre-registration data by the processor; sequentially updating a completion area displayed on a user interface by the processor according to relative position relationships of the feature points of the swipe frames; and determining whether the pre-registration data satisfies a preset completion condition by the processor, so as to determine whether to end the fingerprint registration.

No. of Pages : 14 No. of Claims : 10

(12) PATENT APPLICATION PUBLICATION

(21) Application No.202017026924 A

(19) INDIA

(22) Date of filing of Application :25/06/2020

(43) Publication Date : 11/06/2021

(54) Title of the invention : LITHIUM ION BATTERY SEPARATOR

(51) International classification	:H01M 2/16, C08J 9/26, C08J 9/36, H01G 11/52, H01G 11/58	(71) Name of Applicant : 1)ASAHI KASEI KABUSHIKI KAISHA Address of Applicant :1-1-2 Yurakucho, Chiyoda-ku, Tokyo 1000006 Japan
(31) Priority Document No	:2018-192964	(72) Name of Inventor :
(32) Priority Date	:11/10/2018	1)ZHANG, Xun
(33) Name of priority country	:Japan	2)KUROKI, Ryo
(86) International Application No	:PCT/JP2019/040342	3)FUKUNAGA, Yuki
Filing Date	:11/10/2019	4)KOBAYASHI, Hiromi
(87) International Publication No	:WO 2020/075865	
(61) Patent of Addition to Application Number	:NA	
Filing Date	:NA	
(62) Divisional to Application Number	:NA	
Filing Date	:NA	

(57) Abstract :

Provided are: a production method for a power storage device separator, including a step in which a porous body formed from a sheet-shaped molded body including a silane-modified polyolefin is brought in contact with a base solution or an acid solution; and a power storage device separator including a microporous membrane having a melting/rupture temperature of 180-220°C as measured using thermomechanical analysis (TMA).

No. of Pages : 77 No. of Claims : 31

(12) PATENT APPLICATION PUBLICATION

(21) Application No.202017026942 A

(19) INDIA

(22) Date of filing of Application :25/06/2020

(43) Publication Date : 11/06/2021

(54) Title of the invention : BUS BAR ASSEMBLY

(51) International classification	:H01M 2/20, H01M 10/48, H01M 2/10, H01M 2/26	(71) Name of Applicant : 1)LG CHEM, LTD. Address of Applicant :128, Yeoui-daero Yeongdeungpo-Gu Seoul 07336 Republic of Korea
(31) Priority Document No	:10-2018-0087149	(72) Name of Inventor :
(32) Priority Date	:26/07/2018	1)YOON, Doo Han
(33) Name of priority country	:Republic of Korea	2)CHOI, Jong Woon
(86) International Application No	:PCT/KR2019/009064	3)YANG, Jae Hun
Filing Date	:23/07/2019	
(87) International Publication No	:WO 2020/022735	
(61) Patent of Addition to Application Number	:NA	
Filing Date	:NA	
(62) Divisional to Application Number	:NA	
Filing Date	:NA	

(57) Abstract :

Disclosed is a bus bar assembly including a frame, a plurality of sensing bus bars integrally provided on the frame, an inter bus bar configured to connect any one pair of sensing bus bars, among the plurality of sensing bus bars, to each other; and a terminal bus bar configured to connect any one of the plurality of sensing bus bars to an external terminal..

No. of Pages : 19 No. of Claims : 9

(54) Title of the invention : METHOD AND SYSTEM FOR PROVIDING EMERGENCY RESCUE REQUEST AND LOSS PREVENTION

(51) International classification	:G08B 21/02, G08B 21/24, G08B 27/00, G08B 21/18
(31) Priority Document No	:10-2018-0074445
(32) Priority Date	:28/06/2018
(33) Name of priority country	:Republic of Korea
(86) International Application No	:PCT/KR2019/004327
Filing Date	:11/04/2019
(87) International Publication No	:WO 2020/004783
(61) Patent of Addition to Application Number	:NA
Filing Date	:NA
(62) Divisional to Application Number	:NA
Filing Date	:NA

(71)**Name of Applicant :**
1)EHI
 Address of Applicant :(Uman-dong) 2nd Floor, 11-3, World cup-ro 357beon-gil, Paldal-gu, Suwon-si, Gyeonggi-do 16234 Republic of Korea

(72)**Name of Inventor :**
1)OH, Seung Jin
2)KIM, Sang Uk

(57) Abstract :

The present invention relates to a method and a system for providing an emergency rescue request and loss prevention, and the method can comprise the steps of: allowing an electronic device connected to a portable device through BLE communication to check an operation mode activation signal; allowing the electronic device to activate a loss prevention mode so as to output an alarm if the operation mode activation signal confirms that the strength of a BLE signal transmitted from the portable device is less than or equal to a threshold value; and allowing the electronic device to activate an emergency rescue request mode so as to transmit, to a pre-stored contact number, a message generated on the basis of data about an external environment obtained from a camera and/or a microphone provided in the electronic device, if the operation mode activation signal is generated from outside the portable device. In addition, other embodiments are applicable.

No. of Pages : 23 No. of Claims : 15

(12) PATENT APPLICATION PUBLICATION

(21) Application No.202017027258 A

(19) INDIA

(22) Date of filing of Application :26/06/2020

(43) Publication Date : 11/06/2021

(54) Title of the invention : APPARATUS AND METHOD FOR TRANSMITTING ASSISTANCE INFORMATION IN A WIRELESS COMMUNICATION SYSTEM

(51) International classification :H04W 72/04, H04W 24/10
(31) Priority Document No :1815917.8
(32) Priority Date :28/09/2018
(33) Name of priority country :U.K.
(86) International Application No :PCT/KR2019/012739
Filing Date :30/09/2019
(87) International Publication No :WO 2020/067834
(61) Patent of Addition to Application Number :NA
Filing Date :NA
(62) Divisional to Application Number :NA
Filing Date :NA

(71)**Name of Applicant :**
1)SAMSUNG ELECTRONICS CO., LTD.
Address of Applicant :129, Samsung-ro, Yeongtong-gu
Suwon-si, Gyeonggi-do 16677 Republic of Korea
(72)**Name of Inventor :**
1)VAN DER VELDE, Himke

(57) Abstract :

The present disclosure relates to a communication method and system for converging a 5th-Generation (5G) communication system or networks beyond 5G communication system for supporting higher data rates beyond a 4th-Generation (4G) system with a technology for Internet of Things (IoT). The present disclosure may be applied to intelligent services based on the 5G communication technology and the IoT-related technology, such as smart home, smart building, smart city, smart car, connected car, health care, digital education, smart retail, security and safety services. Disclosed is a method of a User Equipment, UE, in a wireless communication system, the method comprising: receiving, from a base station, configuration information on reporting assistance information associated with an overheating; detecting the overheating; and transmitting, to the base station, the assistance information including first information for controlling a bandwidth associated with at least one of a first frequency range or a second frequency range based on UE's preference, wherein a first frequency corresponding to the first frequency range is smaller from a second frequency corresponding to the second frequency range.

No. of Pages : 30 No. of Claims : 15

(12) PATENT APPLICATION PUBLICATION

(21) Application No.202017027591 A

(19) INDIA

(22) Date of filing of Application :29/06/2020

(43) Publication Date : 11/06/2021

(54) Title of the invention : BWP SWITCHING METHOD AND APPARATUS, AND TERMINAL DEVICE

(51) International classification :H04W 72/04
(31) Priority Document No :201810646706.3
(32) Priority Date :21/06/2018
(33) Name of priority country :China
(86) International Application No :PCT/CN2019/085834
Filing Date :07/05/2019
(87) International Publication No :WO 2019/242419
(61) Patent of Addition to Application Number :NA
Filing Date :NA
(62) Divisional to Application Number :NA
Filing Date :NA

(71)**Name of Applicant :**
1)GUANGDONG OPPO MOBILE TELECOMMUNICATIONS CORP., LTD.
Address of Applicant :No. 18, Haibin Road Wusha, Chang'an Dongguan, Guangdong 523860 China
(72)**Name of Inventor :**
1)SHI, Cong

(57) Abstract :

The embodiments of the present application provide a BWP switching method and apparatus, and a terminal device. The method comprises: a terminal device acquiring first configuration information, wherein the first configuration information comprises first resource information and identifier information of a first search space, the first resource information is used for initiating a random access process, the identifier information of the first search space is used for detecting a downlink control channel, the first configuration information corresponds to a first BWP, and the first search space corresponds to a second BWP; and where the first BWP is in an activated state, the terminal device switching the second BWP to an activated state or maintaining the second BWP in an activated state, and executing the random access process on the first BWP and the second BWP.

No. of Pages : 20 No. of Claims : 14

(12) PATENT APPLICATION PUBLICATION

(21) Application No.202017039166 A

(19) INDIA

(22) Date of filing of Application :10/09/2020

(43) Publication Date : 11/06/2021

(54) Title of the invention : MULTIPOINT PLATE FOR A BIOPROCESS BAG

(51) International classification :C12M 1/00, C12M
1/12

(31) Priority Document No :62/660295

(32) Priority Date :20/04/2018

(33) Name of priority country :U.S.A.

(86) International Application No :PCT/EP2019/059917

Filing Date :17/04/2019

(87) International Publication No :WO 2019/201990

(61) Patent of Addition to Application
Number :NA

Filing Date :NA

(62) Divisional to Application Number :NA

Filing Date :NA

(71)Name of Applicant :

1)GLOBAL LIFE SCIENCES SOLUTIONS USA LLC

Address of Applicant :100 Results Way Marlborough,

Massachusetts 01752 U.S.A.

2)GE HEALTHCARE BIO-SCIENCES AB

(72)Name of Inventor :

1)MILLER, Michael, Jason

2)SAUKKONEN, Hanna-Leena

(57) Abstract :

The invention relates to a a single-use flexible bioreactor bag comprising a rigid multipoint plate sealed to a side wall of said bioreactor bag, wherein said multipoint plate comprises a plurality of ports. The invention further relates to a method of manufacturing the bag and to a method of installing the bag in a rigid support vessel.

No. of Pages : 7 No. of Claims : 17

(12) PATENT APPLICATION PUBLICATION

(21) Application No.202017040810 A

(19) INDIA

(22) Date of filing of Application :21/09/2020

(43) Publication Date : 11/06/2021

(54) Title of the invention : ROTARY DRIVEN FIRING MEMBERS WITH DIFFERENT ANVIL AND CHANNEL ENGAGEMENT FEATURES

(51) International classification	:A61B 17/068, A61B 17/29	(71) Name of Applicant : 1)ETHICON LLC Address of Applicant :#475 Street C, Suite 401 Los Frailes Industrial Park Guaynabo, USA, 00969 U.S.A.
(31) Priority Document No	:62/649291	
(32) Priority Date	:28/03/2018	
(33) Name of priority country	:U.S.A.	(72) Name of Inventor :
(86) International Application No	:PCT/IB2019/052570	1)SHELTON, IV, Frederick E.
Filing Date	:28/03/2019	2)HARRIS, Jason L.
(87) International Publication No	:WO 2019/186472	3)BAXTER, III, Chester O.
(61) Patent of Addition to Application Number	:NA	4)BAKOS, Gregory J.
Filing Date	:NA	
(62) Divisional to Application Number	:NA	
Filing Date	:NA	

(57) Abstract :

A surgical end effector that includes a channel that is configured to operably support a surgical staple cartridge therein and an anvil that is movable between an open position and a closed position. A rotary driven firing member is configured to move axially between a starting position and an ending position. The rotary driven firing member includes at least one anvil engagement member that is configured to engage the anvil and at least one channel engagement member that is configured to engage the channel. The anvil engagement members may differ in size and length from the channel engagement members. The channel engagement members may have different channel engagement surfaces thereon that are formed at angles relative to each other.

No. of Pages : 118 No. of Claims : 20

(12) PATENT APPLICATION PUBLICATION

(21) Application No.202017045402 A

(19) INDIA

(22) Date of filing of Application :19/10/2020

(43) Publication Date : 11/06/2021

(54) Title of the invention : ANODE ACTIVE MATERIAL FOR SECONDARY BATTERY, ANODE COMPRISING SAME, AND METHOD FOR MANUFACTURING SAME

(51) International classification :H01M0004360000,
H01M0004587000,
H01M0010052500,
H01M0004133000,
H01M0004020000

(31) Priority Document No :10-2018-0163075

(32) Priority Date :17/12/2018

(33) Name of priority country :Republic of Korea

(86) International Application No :PCT/KR2019/017411
Filing Date :10/12/2019

(87) International Publication No :WO 2020/130465

(61) Patent of Addition to Application Number :NA
Filing Date :NA

(62) Divisional to Application Number :NA
Filing Date :NA

(71)Name of Applicant :

1)LG CHEM, LTD.

Address of Applicant :128, Yeoui-daero, Yeongdeungpo-Gu, Seoul 07336 Republic of Korea

(72)Name of Inventor :

1)CHOI, Hee Won

2)KIM, Je Young

3)WOO, Sang Wook

4)PIAO, Li Lin

(57) Abstract :

The present invention relates to an anode active material for a secondary battery, which has improved cycle swelling properties and rapid charge performance, an anode comprising same, and a method for manufacturing same. The anode active material is a mixture of artificial graphite and spherical natural graphite, wherein the spherical natural graphite has an average particle diameter (D 50) of 12 or less, with D 90-D 10 value ranging from 5 to 12.

No. of Pages : 38 No. of Claims : 10

(12) PATENT APPLICATION PUBLICATION

(21) Application No.202017054012 A

(19) INDIA

(22) Date of filing of Application :11/12/2020

(43) Publication Date : 11/06/2021

(54) Title of the invention : BENZIMIDAZOLE COMPOUND OR SALT THEREOF, AGRICULTURAL AND HORTICULTURAL INSECTICIDAL AND ACARICIDAL AGENT CONTAINING SAID COMPOUND, AND METHOD FOR USING SAME

(51) International classification	:A61P0033140000, A01N0043900000, C07D0413040000, C07D0487040000, A01N0043520000	(71) Name of Applicant : 1)NIHON NOHYAKU CO., LTD. Address of Applicant :19-8, Kyobashi 1-Chome, Chuo-ku, Tokyo 1048386 Japan
(31) Priority Document No	:2018-097629	(72) Name of Inventor :
(32) Priority Date	:22/05/2018	1)FUJIHARA, Hirokazu
(33) Name of priority country	:Japan	2)ABE, Yutaka
(86) International Application No	:PCT/JP2019/020325	3)TANAKA, Ryosuke
Filing Date	:22/05/2019	4)FUCHI, Shunsuke
(87) International Publication No	:WO 2019/225663	
(61) Patent of Addition to Application Number	:NA	
Filing Date	:NA	
(62) Divisional to Application Number	:NA	
Filing Date	:NA	

(57) Abstract :

The present invention addresses the problem of developing and providing a novel agricultural and horticultural insecticidal and acaricidal agent for crop production, such as agricultural and horticultural, in view of factors such as damage caused by pests that is currently severe and the emergence of pests resistant to existing agents. The present invention provides: a benzimidazole compound or a salt thereof represented by general formula (1) [Compound 1] {In the formula, R denotes an alkyl group or the like, R1 denotes a haloalkyl group or the like, X denotes an oxygen atom or the like, and m and n are 0 etc.}; an agricultural and horticultural insecticidal and acaricidal agent containing said compound as an active ingredient; and a method for using same.

No. of Pages : 115 No. of Claims : 8

(12) PATENT APPLICATION PUBLICATION

(21) Application No.202017054333 A

(19) INDIA

(22) Date of filing of Application :14/12/2020

(43) Publication Date : 11/06/2021

(54) Title of the invention : A CLIENT-SERVER COMPUTER SYSTEM

(51) International classification	:H04L0009000000, H04L0029060000, H04L0009080000, H04L0009320000, G06F0016951000	(71) Name of Applicant : 1)CITY, UNIVERSITY OF LONDON Address of Applicant :Research and Enterprise Office Drysdale Building E213 Northampton Square London Greater London EC1V 0HB U.K.
(31) Priority Document No	:1900354.0	(72) Name of Inventor :
(32) Priority Date	:10/01/2019	1)TAHIR, Shahzaib
(33) Name of priority country	:U.K.	2)RAJARAJAN, Muttukrishnan
(86) International Application No	:PCT/GB2019/053490	
Filing Date	:10/12/2019	
(87) International Publication No	:WO 2020/144449	
(61) Patent of Addition to Application Number	:NA	
Filing Date	:NA	
(62) Divisional to Application Number	:NA	
Filing Date	:NA	

(57) Abstract :

A client-server computer system (10) for a client (12) to search for a keyword in at least partially homomorphically encrypted documents (18) stored in a server (14) is disclosed. The client-server computer system (10) is configured as follows. The client (12) applies probabilistic symmetric encryption to a keyword to form a probabilistically encrypted keyword to form a first result. The client (12) applies deterministic symmetric encryption to the keyword to form a deterministically encrypted keyword, then computes a modular inverse of the deterministically encrypted keyword, and then applies at least partially homomorphic encryption to the modular inverse deterministically encrypted keyword to form a second result. The client (12) uses a session key to hash the first result to form a hash result. The client (12) combines the first result and second result to form a third result. The client (12) encrypts the third result and the hash result using a private key to generate the search query. The client (12) sends the search query to the server (14). The server (14) receives the search query from the client (12). The server (14) identifies at least one identifier of at least one document of the at least partially homomorphically encrypted documents including the keyword by decrypting, using a public key, a product of the search query and the hash result. The server (14) sends the at least one identifier in encrypted form to the client (12). The client (12) decrypts the at least one identifier.

No. of Pages : 22 No. of Claims : 25

(12) PATENT APPLICATION PUBLICATION

(21) Application No.202017054897 A

(19) INDIA

(22) Date of filing of Application :17/12/2020

(43) Publication Date : 11/06/2021

(54) Title of the invention : POLYMERASES, COMPOSITIONS, AND METHODS OF USE

(51) International classification	:C12N0009120000, A61K0009140000, C12Q0001686000, A61K0009000000, C12Q0001684400	(71) Name of Applicant : 1)ILLUMINA, INC. Address of Applicant :5200 Illumina Way San Diego, California 92122 U.S.A. 2)ILLUMINA CAMBRIDGE LIMITED 3)ILLUMINA SINGAPORE PTE. LTD.
(31) Priority Document No	:62/775662	(72) Name of Inventor :
(32) Priority Date	:05/12/2018	1)KLAUSING, Kay
(33) Name of priority country	:U.S.A.	2)GHOMI, Hamed Tabatabaei
(86) International Application No	:PCT/US2019/064524	3)GOLYNSKIY, Misha
Filing Date	:04/12/2019	4)NIRANTAR, Saurabh
(87) International Publication No	:WO 2020/117968	5)MCDONALD, Seth
(61) Patent of Addition to Application Number	:NA	6)PEISAJOVICH, Sergio
Filing Date	:NA	
(62) Divisional to Application Number	:NA	
Filing Date	:NA	

(57) Abstract :

Presented herein are altered polymerase enzymes for improved incorporation of nucleotides and nucleotide analogues, in particular altered polymerases that maintain high fidelity under reduced incorporation times, as well as methods and kits using the same.

No. of Pages : 52 No. of Claims : 90

(12) PATENT APPLICATION PUBLICATION

(21) Application No.202017056710 A

(19) INDIA

(22) Date of filing of Application :28/12/2020

(43) Publication Date : 11/06/2021

(54) Title of the invention : METHOD FOR MANUFACTURING STEAM TURBINE DIAPHRAGM

(51) International classification :F01D0005220000,
F01D0025240000,
F01D0011080000,
F01D0025260000,
H04R0009060000

(31) Priority Document No :2019-034598

(32) Priority Date :27/02/2019

(33) Name of priority country :Japan

(86) International Application No :PCT/JP2019/047495
Filing Date :04/12/2019

(87) International Publication No :WO 2020/174801

(61) Patent of Addition to Application Number :NA
Filing Date :NA

(62) Divisional to Application Number :NA
Filing Date :NA

(71)**Name of Applicant :**
1)MITSUBISHI POWER, LTD.
Address of Applicant :3-1, Minatomirai 3-chome, Nishi-ku,
Yokohama-shi, Kanagawa 2208401 Japan

(72)**Name of Inventor :**
1)KAWANO Takanori
2)KUBO Naoto
3)OGASAWARA Nozomu

(57) Abstract :

This diaphragm for a steam turbine has a diaphragm inner wheel, a diaphragm outer wheel, and a wing section that are integrally formed, wherein: the diaphragm comprises a collector ring that holds a seal fin having a radial spill strip structure, and an adapter ring that is interposed between the diaphragm outer wheel and the collector ring; the collector ring and the adapter ring have an outer diameter that is larger than the diaphragm outer wheel; the diaphragm outer wheel and the adapter ring are interconnected using a plurality of first bolts; the opposing surfaces of the diaphragm outer wheel and the adapter ring are brought into close contact with each other so as to be sealed; and the collector ring and the adapter ring are interconnected using a plurality of second bolts in positions further on the outer circumferential side than the seal fin.

No. of Pages : 27 No. of Claims : 5

(12) PATENT APPLICATION PUBLICATION

(21) Application No.202018049865 A

(19) INDIA

(22) Date of filing of Application :16/11/2020

(43) Publication Date : 11/06/2021

(54) Title of the invention : NEWCASTLE DISEASE VIRUSES AND USES THEREOF

(51) International classification	:A61K0039170000, C12N0007000000, A61K0039395000, A61K0035768000, A61K0039000000	(71) Name of Applicant : 1)ICAHN SCHOOL OF MEDICINE AT MOUNT SINAI Address of Applicant :One Gustave L. Levy Place New York, NY 10029 (US) U.S.A. 2)MEMORIAL SLOAN KETTERING CANCER CENTER
(31) Priority Document No	:61/782,994	(72) Name of Inventor :
(32) Priority Date	:14/03/2013	1)PALESE, Peter
(33) Name of priority country	:U.S.A.	2)GARCIA-SASTRE, Adolfo
(86) International Application No	:PCT/US2014/020299	3)ZAMARIN, Dmitriy
Filing Date	:04/03/2014	4)ALLISON, James
(87) International Publication No	: NA	5)WOLCHOK, Jedd, D.
(61) Patent of Addition to Application Number	:NA	
Filing Date	:NA	
(62) Divisional to Application Number	:8204/DELNP/2015	
Filed on	:10/09/2015	

(57) Abstract :

Described herein are chimeric Newcastle disease viruses engineered to express an agonist of a co-stimulatory signal of an immune cell and compositions comprising such viruses. Also described herein are chimeric Newcastle disease viruses engineered to express an antagonist of an inhibitory signal of an immune cell and compositions comprising such viruses. The chimeric Newcastle disease viruses and compositions are useful in the treatment of cancer. In addition, described herein are methods for treating cancer comprising administering Newcastle disease viruses in combination with an agonist of a co-stimulatory signal of an immune and/or an antagonist of an inhibitory signal of an immune cell.

No. of Pages : 196 No. of Claims : 14

(12) PATENT APPLICATION PUBLICATION

(21) Application No.202117002161 A

(19) INDIA

(22) Date of filing of Application :18/01/2021

(43) Publication Date : 11/06/2021

(54) Title of the invention : BATTERY CELL CONNECTOR, AND BATTERY CELL STRUCTURE CONNECTED USING SAME

(51) International classification :H01M0002100000,
H01M0002300000,
H01M0002200000,
H01M0010040000,
H01Q0009420000

(31) Priority Document No :10-2018-0164151

(32) Priority Date :18/12/2018

(33) Name of priority country :Republic of Korea

(86) International Application No :PCT/KR2019/017406
Filing Date :10/12/2019

(87) International Publication No :WO 2020/130464

(61) Patent of Addition to Application Number :NA
Filing Date :NA

(62) Divisional to Application Number :NA
Filing Date :NA

(71)Name of Applicant :

1)LG CHEM, LTD.

Address of Applicant :128,Yeoui-daero Yeongdeungpo-Gu
Seoul 07336 Republic of Korea

(72)Name of Inventor :

1)KIM, Yong Han

2)PARK, Pil Kyu

3)SUNG, Joo Hwan

4)BOK, Cheon Hee

(57) Abstract :

The present invention relates to a battery cell connector having a generally hexahedral shape, comprising: a lower mounting part provided on the upper surface thereof so as to mount the lower portion of a cylindrical-shaped battery cell in the lower mounting part; an upper mounting part provided on the lower surface thereof so as to mount the upper portion of another cylindrical-shaped battery cell in the upper mounting part; and connection parts provided on the front surface, the rear surface, the left surface, and the right surface thereof, which can be electrically and physically connected to other battery cells different from each other, wherein the lower mounting part, the upper mounting part, and the connection parts are electrically connected to each other inside the battery cell connector.

No. of Pages : 20 No. of Claims : 9

(12) PATENT APPLICATION PUBLICATION

(21) Application No.202117004510 A

(19) INDIA

(22) Date of filing of Application :02/02/2021

(43) Publication Date : 11/06/2021

(54) Title of the invention : REFERENCE CORE POSITION CALCULATION DEVICE FOR ELEVATOR AND REFERENCE CORE CALCULATION METHOD

(51) International classification	:B66B0011000000, G01B0011000000, H04W0024100000, B66B0005000000, H04W0072080000	(71) Name of Applicant : 1)HITACHI BUILDING SYSTEMS CO., LTD. Address of Applicant :2-101, Kandaawaji-cho, Chiyoda-ku, Tokyo 1018941 Japan
(31) Priority Document No	:2019-031087	(72) Name of Inventor :
(32) Priority Date	:22/02/2019	1)TAGUCHI, Hirofumi
(33) Name of priority country	:Japan	2)NOGUCHI, Naoaki
(86) International Application No	:PCT/JP2019/047659	3)MATSUKA, Daisuke
Filing Date	:05/12/2019	4)YAGI, Nobuaki
(87) International Publication No	:WO 2020/170551	5)ITOU, Masato
(61) Patent of Addition to Application Number	:NA	
Filing Date	:NA	
(62) Divisional to Application Number	:NA	
Filing Date	:NA	

(57) Abstract :

This reference core position calculation device 100, which calculates the reference core position of a hoistway in which an elevator is installed, has a measurement unit 101 and a calculation unit 112. The measurement unit 101 measures the dimension of each part of the hoistway. The calculation unit 112 calculates a dimension value of each part of the hoistway on the basis of the reference core position and the dimension of each part measured by the measurement unit 101. When the reference core position is set as a first reference core position, the calculation unit 112 determines, on the basis of a first reference core position, whether or not the dimension value of each part of the hoistway satisfies a predetermined specification.

No. of Pages : 40 No. of Claims : 8

(12) PATENT APPLICATION PUBLICATION

(21) Application No.202117005149 A

(19) INDIA

(22) Date of filing of Application :06/02/2021

(43) Publication Date : 11/06/2021

(54) Title of the invention : BIFUNCTIONAL ANGIOGENESIS INHIBITOR AND USE THEREOF

(51) International classification	:C07K0005103000, A61P0029000000, C07D0213820000, A61K0031443900, C07K0014810000	(71) Name of Applicant : 1)REMEGEN CO., LTD. Address of Applicant :No. 58 Beijing Middle Road, Yantai Development Zone Yantai District, China (Shandong) Pilot Free Trade Zone Shandong 264006 China
(31) Priority Document No	:201811491023.1	(72) Name of Inventor :
(32) Priority Date	:07/12/2018	1)JIANG, Jing
(33) Name of priority country	:China	2)FANG, Jianmin
(86) International Application No	:PCT/CN2019/122854	3)LUAN, Xuejing
Filing Date	:04/12/2019	4)YAO, Xuejing
(87) International Publication No	:WO 2020/114411	5)WANG, Ling
(61) Patent of Addition to Application Number	:NA	
Filing Date	:NA	
(62) Divisional to Application Number	:NA	
Filing Date	:NA	

(57) Abstract :

The present invention relates to a bifunctional angiogenesis inhibitor having VEGF inhibitory activities and FGF inhibitory activities and capable of inhibiting VEGF and FGF dual factors or high sugar-induced cell proliferation, cell migration and/or lumen formation. The present invention also relates to use of the bifunctional vascular inhibitor for inhibiting retinal angiogenesis, such as diabetic retinopathy, age-related macular degeneration.

No. of Pages : 24 No. of Claims : 20

(12) PATENT APPLICATION PUBLICATION

(21) Application No.202117008739 A

(19) INDIA

(22) Date of filing of Application :02/03/2021

(43) Publication Date : 11/06/2021

(54) Title of the invention : THREE-DIMENSIONAL HEAT-SAVING CONSTRUCTION PANEL, DEVICE AND METHOD FOR PREPARING SAME (VARIATIONS)

(51) International classification	:B29L0031000000, E04B0002700000, C04B0111600000, C04B0111280000, E04B0001140000	(71) Name of Applicant : 1)CHOLPONALY, uulu Usenkul Address of Applicant :per. Samarkandsky - 9, g. Bishkek, Kyrgyz Republic
(31) Priority Document No	:20190007.1	(72) Name of Inventor : 1)CHOLPONALY, uulu Usenkul
(32) Priority Date	:06/02/2019	
(33) Name of priority country	:Kyrgyz Republic	
(86) International Application No	:PCT/KG2019/000001	
Filing Date	:05/12/2019	
(87) International Publication No	:WO 2020/162641	
(61) Patent of Addition to Application Number	:NA	
Filing Date	:NA	
(62) Divisional to Application Number	:NA	
Filing Date	:NA	

(57) Abstract :

The present invention relates to the field of construction, specifically to building structures and methods and devices for the production thereof, and can be used as three-dimensional heat-saving panels for rapidly erecting load-bearing walls in buildings for various purposes and floors therein, as well as external walls, partitions and roofs which satisfy enhanced thermal resistance requirements for building envelopes in the construction industry. The invention addresses the problem of creating a three-dimensional heat-saving wall panel (variations) with enhanced thermal resistance which satisfies the requirements of passive building parameters, developing a method for the manufacture thereof which allows a reduction in material consumption, energy consumption and labor intensity, and developing a block-form structure (variations) for the preparation thereof.

No. of Pages : 14 No. of Claims : 17

(12) PATENT APPLICATION PUBLICATION

(21) Application No.202117011427 A

(19) INDIA

(22) Date of filing of Application :17/03/2021

(43) Publication Date : 11/06/2021

(54) Title of the invention : METHOD OF CONTROLLING CABLE DRIVEN END EFFECTORS

(51) International classification :A61B0034300000,
B25J0009160000,
A61B0034000000,
A61B0034370000,
B60W0010080000

(31) Priority Document No :62/776285
(32) Priority Date :06/12/2018
(33) Name of priority country :U.S.A.
(86) International Application No :PCT/US2019/064867
Filing Date :06/12/2019
(87) International Publication No :WO 2020/118149
(61) Patent of Addition to Application Number :NA
Filing Date :NA
(62) Divisional to Application Number :NA
Filing Date :NA

(71)Name of Applicant :

1)COVIDIEN LP

Address of Applicant :15 Hampshire Street Mansfield,
Massachusetts 02048 U.S.A.

(72)Name of Inventor :

1)ROCKROHR, Brian

2)CHENG, Jiqi

3)RAHMAN, Farrukh

4)MEGLAN, Dwight

5)WELLS, Brian

6)AGRAWAL, Alok

(57) Abstract :

A method of controlling an end effector of a surgical robot includes receiving a desired pose, generating motor torques, transmitting the motor torques, generating null torques, generating desired torques, and transmitting the desired torques to an IDU such that the IDU moves the end effector to the desired pose. A primary controller receives the desired pose of the end effector in three DOF. The primary controller generates the motor torques in response to receiving the desired pose. The primary controller transmits the motor torques which are received in a secondary controller. The secondary controller generates null torques to maintain tension in cables of a differential drive mechanism of the IDU. The desired torques are generated for each motor of the IDU to include a sum of the motor torques and the null torques.

No. of Pages : 54 No. of Claims : 20

(12) PATENT APPLICATION PUBLICATION

(21) Application No.202117014732 A

(19) INDIA

(22) Date of filing of Application :31/03/2021

(43) Publication Date : 11/06/2021

(54) Title of the invention : METHOD FOR MEASURING GEOMETRIC DISCREPANCIES BETWEEN THE CURVED SURFACES OF A PLURALITY OF MATERIALS THAT ARE TO BE EVALUATED AND A CURVED SURFACE OF A REFERENCE MATERIAL

(51) International classification	:G01B0011240000, F16C0019380000, G06T0007600000, A61B0006000000, G01N0029300000	(71) Name of Applicant : 1)SAINT-GOBAIN GLASS FRANCE Address of Applicant :12 place de l'Iris Tour Saint-Gobain 92400 Courbevoie France
(31) Priority Document No	:1872770	(72) Name of Inventor :
(32) Priority Date	:12/12/2018	1)CARLU, Adrien
(33) Name of priority country	:France	2)MARLIER, Alexandre
(86) International Application No	:PCT/EP2019/083920	
Filing Date	:06/12/2019	
(87) International Publication No	:WO 2020/120294	
(61) Patent of Addition to Application Number	:NA	
Filing Date	:NA	
(62) Divisional to Application Number	:NA	
Filing Date	:NA	

(57) Abstract :

The present invention relates to the field of the checking of the reliefs of the curved surfaces of materials, particularly curved surfaces of window glazing designed for means of transport, notably in the automotive industry. The subjects of the invention are a method and system for measuring the geometric discrepancies between the curved surfaces of a plurality of materials that are to be evaluated and a curved surface of a reference material.

No. of Pages : 14 No. of Claims : 17

(54) Title of the invention : A PROCESS FOR SYNTHESIS OF FIPRONIL

(51) International classification	:A01N0047020000, C07D0231440000, G11B0027034000, H04N0009806000, H04N0005907000	(71) Name of Applicant : 1)GHARDA CHEMICALS LIMITED Address of Applicant :D-1/2, MIDC, Lote Parshuram, Taluka Khed, Ratnagiri-415722, Maharashtra, India Maharashtra India
(31) Priority Document No	:NA	(72) Name of Inventor :
(32) Priority Date	:NA	1)GHARDA, Keki Hormusji
(33) Name of priority country	:NA	2)SHENOY, Diwakar
(86) International Application No	:NA	3)SHET, Laxminarayan
Filing Date	:NA	4)SAMANGADKAR, Yatin
(87) International Publication No	: NA	5)KAWADE, Abhijeet Suresh
(61) Patent of Addition to Application Number	:NA	
Filing Date	:NA	
(62) Divisional to Application Number	:NA	
Filing Date	:NA	

(57) Abstract :

The process of the present disclosure provides fipronil with a yield in the range of 75% to 90% and purity in the range of 95% to 97%. By the process of the present disclosure, the amount of sulfone impurity i.e., 5-amino-1-(2,6-dichloro-4- trifluoromethylphenyl)-3-cyano-4-trifluoro methylsulfonyl pyrazole in fipronil observed is in the range of 0 % to 0.5 %.

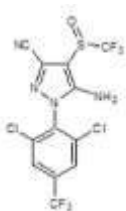

No. of Pages : 25 No. of Claims : 13

(12) PATENT APPLICATION PUBLICATION

(21) Application No.201921022356 A

(19) INDIA

(22) Date of filing of Application :05/12/2019

(43) Publication Date : 11/06/2021

(54) Title of the invention : IMPROVED SELF-ACTUATED PNEUMATIC DRIVE SYSTEM

(51) International classification :E21B0034100000,
E21B0033122000,
F01B0003000000,
F01B0003040000,
A61B0017000000

(31) Priority Document No :NA
(32) Priority Date :NA
(33) Name of priority country :NA
(86) International Application No :NA
Filing Date :NA
(87) International Publication No : NA
(61) Patent of Addition to Application Number:NA
Filing Date :NA
(62) Divisional to Application Number :NA
Filing Date :NA

(71)Name of Applicant :

1)PILOT FLUID TECHNOLOGIES LLP

Address of Applicant :A114, H-block, MIDC , Pimpri ,
PUNE- 411018, Maharashtra State, India Maharashtra India

(72)Name of Inventor :

1)NARAYAN VILAS DESHPANDE

(57) Abstract :

The present invention provides an improved self-actuated pneumatic drive system that includes an exponential air pilot with differential resultant force exerting area sliding valve mechanism involving a double acting pneumatic cylinder assembly (10) configured with an inner holding tube (20) axially disposed with a floating member (30) therein along with a top valve (40) and a bottom valve (50)respectively having a top sliding member (80) and a bottom sliding member (90) slidably positioned thereon and interconnected by the floating member (30). The system (200) includes a pilot member (120) slidably disposed into the floating member (30) for being pushed or pulled by a connecting rod (130). The system (200) includes a pair of rods (140)which connect to a disc (160) that moves within a cavity of the double acting pneumatic cylinder assembly (10) during actuation thereof.

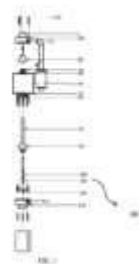

No. of Pages : 14 No. of Claims : 7

(54) Title of the invention : AN IN-WHEEL ELECTRIC ALL-TERRAIN VEHICLE

(51) International classification	:B60K0007000000, B60K0017040000, B60W0030040000, B62K0005010000, B60L0015200000	(71) Name of Applicant : 1)Powerland Agro Tractor Vehicles Private Limited Address of Applicant :Bungalow No. 3 Costa Row House, Aquem Alto, Margao Goa.403601 Goa India
(31) Priority Document No	:NA	(72) Name of Inventor :
(32) Priority Date	:NA	1)Tej Narayan Naik
(33) Name of priority country	:NA	2)Narayan Pundalik Naik
(86) International Application No	:NA	3)Amit Sukumar Santra
Filing Date	:NA	
(87) International Publication No	: NA	
(61) Patent of Addition to Application Number	:NA	
Filing Date	:NA	
(62) Divisional to Application Number	:NA	
Filing Date	:NA	

(57) Abstract :

Disclosed is an in-wheel electric all-terrain vehicle (100). The in-wheel electric all-terrain vehicle (100) includes a powertrain (126) to provide power drive from the engine (102) to at least one of the right front wheel (104), the left front wheel (106), the right rear wheel (108), and the left rear wheel (110), wherein the powertrain (126) includes the engine (102), one or more drive shafts (128), and a final drive (130); an electric in-wheel motor assembly (132) mounted inside each of the four wheels (104, 106, 108, 110), wherein the electric in-wheel motor assembly (132) includes a main shaft (134), one or more stator coils (136), a stator holder (138), a stator coil winding (140), one or more magnets (142), a magnet ring holder (144), one or more bearings (146), a casing (148), one or more internal and external circlips (150). FIG. 1

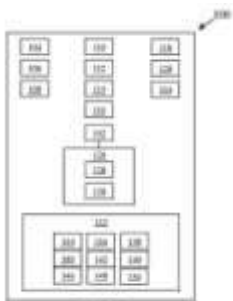

FIG. 1

No. of Pages : 18 No. of Claims : 10

(54) Title of the invention : WATER PURIFICATION SYSTEM

(51) International classification	:C02F0001440000, B01D0061100000, B01D0061020000, B01D0061080000, C02F0001140000	(71) Name of Applicant : 1)SANANDAN SUDHIR Address of Applicant :C2 801, Waterlily, Adani Shantigram, Ahmedabad, Gujarat, India. Gujarat India
(31) Priority Document No	:NA	(72) Name of Inventor :
(32) Priority Date	:NA	1)SANANDAN SUDHIR
(33) Name of priority country	:NA	2)AKSHAY
(86) International Application No	:NA	
Filing Date	:NA	
(87) International Publication No	: NA	
(61) Patent of Addition to Application Number	:NA	
Filing Date	:NA	
(62) Divisional to Application Number	:NA	
Filing Date	:NA	

(57) Abstract :

A water purification system based on mechanical valves and manual operation without requirement of electric power is disclosed. The system includes a feed water container for storage of feed water, a plurality of reverse osmosis filter cartridges for filtering the feed water, and a manually operated pneumatic pump for pressurizing the feed water container for feed water to flow under pressure to filter cartridges for purification. The mechanical valves ensure that water pressure in the water purification system does not go below an operating pressure due to draining out of the waste water, or due to return of the feed water to the feed water container, and filtration of the feed water takes place only when usable water is being drawn from the system. A mechanism to fill feed water into the pressurized storage container without significant loss of pressure in the feed water storage container is also disclosed.

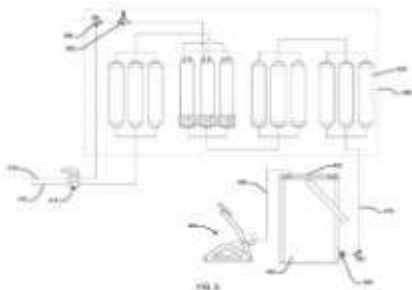

No. of Pages : 43 No. of Claims : 20

(54) Title of the invention : UNDER-RUN PROTECTION DEVICE

(51) International classification	:B60R0019560000, G11B0020100000, H04J0003060000, H01L0027020000, G11B0007004500	(71) Name of Applicant : 1)MR. SANTOSH ARVIND PRADHAN Address of Applicant :YUGAYA COMPLEX, FLAT NO.A4, 5/5, CTS 7+8/10 ERANDWANE, SHANKARRAO JOSHI MARG, NEAR NAL STOP, BEHIND LAGUBANDHU JEWELLERS, PUNE (M.S) 411004 INDIA Maharashtra India
(31) Priority Document No	:NA	(72) Name of Inventor :
(32) Priority Date	:NA	1)MR. SANTOSH ARVIND PRADHAN
(33) Name of priority country	:NA	
(86) International Application No	:NA	
Filing Date	:NA	
(87) International Publication No	: NA	
(61) Patent of Addition to Application Number	:NA	
Filing Date	:NA	
(62) Divisional to Application Number	:NA	
Filing Date	:NA	

(57) Abstract :

ABSTRACT UNDER-RUN PROTECTION DEVICE An under-run protection device 100 that is mounted on a chassis 120 of a vehicle 110 is disclosed. The under-run protection device is positioned ahead of front wheels 140 and rear wheels 150 of the vehicle 110. The device includes a first connector assembly 200 that is removably connectable to the chassis the chassis 120. A second protector assembly 205 is rotatably connected to the first connector assembly 200 by a hinge 215. A third spring assembly 210 is securely connected to the second protector assembly 205. The device operates in a first working position and the device has a second folded position. FIG.1 for Publication

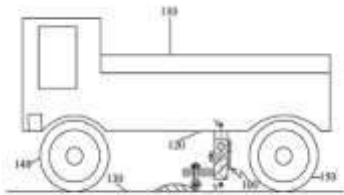

FIG. 1

No. of Pages : 46 No. of Claims : 18

(54) Title of the invention : METHOD PROVIDING PIPELINING OF CACHE DATA AND A SYSTEM THEREOF

<p>(51) International classification</p> <p>(31) Priority Document No</p> <p>(32) Priority Date</p> <p>(33) Name of priority country</p> <p>(86) International Application No</p> <p style="padding-left: 20px;">Filing Date</p> <p>(87) International Publication No</p> <p>(61) Patent of Addition to Application Number:</p> <p style="padding-left: 20px;">Filing Date</p> <p>(62) Divisional to Application Number</p> <p style="padding-left: 20px;">Filing Date</p>	<p>:G06F0012086200, G06F0013160000, G06F0013364000, G06F0012080200, G06F0012087500</p> <p>:NA</p> <p>:NA</p> <p>:NA</p> <p>:NA</p> <p>:NA</p> <p>: NA</p> <p>:NA</p> <p>:NA</p> <p>:NA</p> <p>:NA</p> <p>:NA</p>	<p>(71)Name of Applicant : 1)Indian Institute of Technology Bombay Address of Applicant :House No. IIT Bombay Street Powai City Mumbai State Maharashtra Country India Pin code 400076 Maharashtra India</p> <p>(72)Name of Inventor : 1)Madhav Pandurang Desai</p>
--	--	---

(57) Abstract :

Method providing pipelining of cache data and a system thereof Embodiments provide a method and a system pipelining cache data. The system comprises a processor and a cache memory having a front-end memory for receiving a stream of incoming request from a Central Processing Unit (CPU). The front-end memory processes, each request in the stream of incoming request in a predefined order based on a check of an exception in each request. The front-end memory maintains a pipeline of the stream of incoming requests while processing each of the request allowing an initiation of a new request during processing of one or more ongoing request. The front-end memory checks, for a corresponding response type to be identified for each request and generates a response according to the corresponding response type. FIG. 2

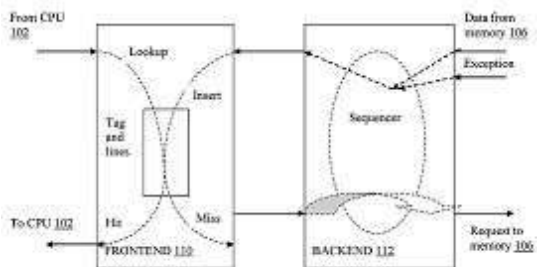

FIG. 2

No. of Pages : 20 No. of Claims : 16

(54) Title of the invention : 1,2-CHLORINATED POLYVINYLCHLORIDE AND A PROCESS FOR ITS PREPARATION

(51) International classification	:H01M0010440000, G11B0017049000, G03G0015080000, A24D0003060000, B65D0006220000	(71)Name of Applicant : 1)RELIANCE INDUSTRIES LIMITED Address of Applicant :3RD FLOOR, MAKER CHAMBER-IV, 222, NARIMAN POINT, MUMBAI-400021, MAHARASHTRA, INDIA Maharashtra India
(31) Priority Document No	:NA	(72)Name of Inventor :
(32) Priority Date	:NA	1)MUNSHI, Pradip
(33) Name of priority country	:NA	2)AGRAWAL, Santosh
(86) International Application No	:NA	3)INGLE, Ninad Deepak
Filing Date	:NA	4)MAITY, Uttam
(87) International Publication No	: NA	5)JASRA, Raksh Vir
(61) Patent of Addition to Application Number	:NA	
Filing Date	:NA	
(62) Divisional to Application Number	:NA	
Filing Date	:NA	

(57) Abstract :

ABSTRACT 1,2-CHLORINATED POLYVINYLCHLORIDE AND A PROCESS FOR ITS PREPARATION The present disclosure relates to 1,2-chlorinated polyvinylchloride (1,2-CPVC) and a process for its preparation. The process of the present disclosure is carried out at a chlorine pressure in the range of 2 to 3.5 kg/cm². 1,2-CPVC obtained by the process of the present disclosure has a chlorine content in the range of 67 to 68%. Further, 1,2-CPVC of the present disclosure is characterized by having no unsaturation in the molecular chain of the CPVC; an inherent viscosity in the range of 0.825 to 0.850; a thermal stability in the range of 800 seconds to 1200 seconds; and a glass transition temperature (T_g) in the range of 150 to 155 °C.

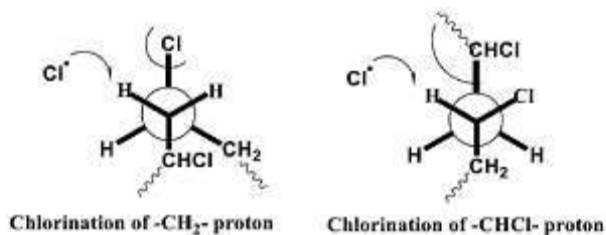

FIGURE 1

No. of Pages : 30 No. of Claims : 10

(54) Title of the invention : METHOD AND SYSTEM FOR RECOMMENDING TOOL CONFIGURATIONS IN MACHINING

(51) International classification	:H04L0029080000, H04N0021274300, B64G0001360000, H04N0001000000, C07D0263320000	(71) Name of Applicant : 1)Tata Consultancy Services Limited Address of Applicant :Nirmal Building, 9th Floor, Nariman Point Mumbai 400021 Maharashtra India Maharashtra India
(31) Priority Document No	:NA	(72) Name of Inventor :
(32) Priority Date	:NA	1)SHARMA, Sunil
(33) Name of priority country	:NA	2)MUHAMMED, Bilal
(86) International Application No	:NA	3)PUSULURI, Srimannarayana
Filing Date	:NA	4)BASAVARSU, Purushottham Gautham
(87) International Publication No	: NA	5)DAS, Prasenjit
(61) Patent of Addition to Application Number	:NA	
Filing Date	:NA	
(62) Divisional to Application Number	:NA	
Filing Date	:NA	

(57) Abstract :

This disclosure relates generally to recommending tool configurations in machining. The machining tool configuration selection involves the selection of several tool specification parameters concerning the material, geometry and composition of the machining tool. The state-of-the-art methods uses a rule and knowledge-based system to select tool configuration, however these methods do not recommend tool configurations which satisfy customer requirement. Embodiments of the present disclosure uses a hierarchical model which is trained to predict acceptable tool specification parameters for a given requirement by learning the patterns from past tool selection data. Further a probabilistic approach is used to predict the top set of recommendations of tool configurations with a probability score for each prediction. The disclosed method is used for recommending tool configurations in a cylindrical grinding wheel process. [To be published with FIG. 2]

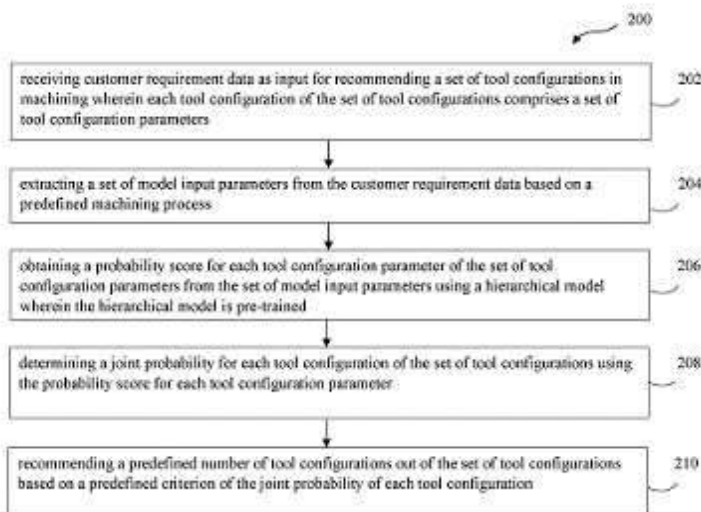

FIG. 2

(54) Title of the invention : POISONOUS GAS DETECTION AND ALARMING DEVICE

(51) International classification	:G01N0033000000, G08B0021140000, G08B0021120000, A62B0018020000, E06B0005140000	(71) Name of Applicant : 1)Indian Institute of Technology, Bombay Address of Applicant :Powai Mumbai 400076 Maharashtra, India Maharashtra India
(31) Priority Document No	:NA	(72) Name of Inventor :
(32) Priority Date	:NA	1)V. Jothiprakash
(33) Name of priority country	:NA	2)Tarika Vohra
(86) International Application No	:NA	
Filing Date	:NA	
(87) International Publication No	: NA	
(61) Patent of Addition to Application Number	:NA	
Filing Date	:NA	
(62) Divisional to Application Number	:NA	
Filing Date	:NA	

(57) Abstract :

The present invention relates to a device for detection of hazardous and poisonous gases. Accordingly, the invention discloses a poisonous gas detection and alarming device which has a plurality of sensors, a plurality of alarming means and a processor. The device, being easy to carry and operate, serves as a life-saving tool which warns users of a hazardous situation, or a toxic gas leak, thereby allowing the users to vacate the affected premises at the earliest. Reference Figure 1

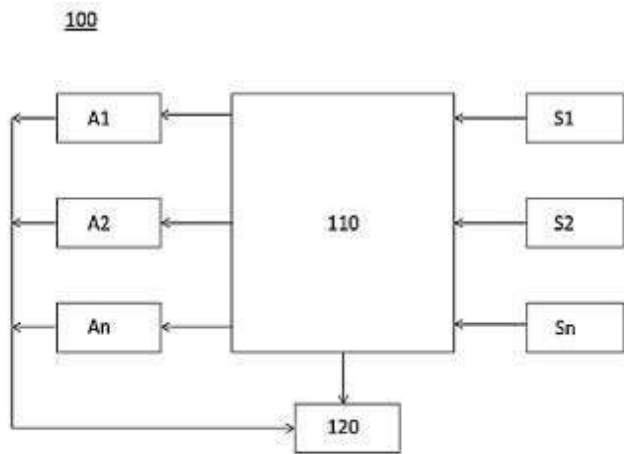

Figure 1

No. of Pages : 15 No. of Claims : 10

(54) Title of the invention : DIGITAL MEDICINE STORAGE AND REMINDER DEVICE

(51) International classification :A61J0007040000,
G08B0021240000,
A61J0001030000,
H04H0020300000,
H04W0004060000

(31) Priority Document No :NA
(32) Priority Date :NA
(33) Name of priority country :NA
(86) International Application No :NA
Filing Date :NA
(87) International Publication No : NA
(61) Patent of Addition to Application Number :NA
Filing Date :NA
(62) Divisional to Application Number :NA
Filing Date :NA

(71)Name of Applicant :
1)PRAJAPATI, Kush Kirtikumar
Address of Applicant :94/1161 Uday Apartments, Near
telephone exchange, Shastrinagar, Naranpura, Ahmedabad-
380063 Gujarat India
2)MANGUKIYA, Harsh Yogeshbhai
3)PARMAR, Dhaumil Dipakbhai

(72)Name of Inventor :
1)MANGUKIYA, Harsh Yogeshbhai
2)PARMAR, Dhaumil Dipakbhai
3)PRAJAPATI, Kush Kirtikumar

(57) Abstract :
ABSTRACT DIGITAL MEDICINE STORAGE AND REMINDER DEVICE The present invention relates to digital medicine storage and reminder device (1) which will store and remind about medicine to the user at specific time. The device comprises storing compartment (100) which comprises a LED (104) with individual light for visual signals to the user that from which compartment (100) medicines is to be taken and audio signal through the buzzer (200) at pre-programmed time. The device is provided with smart display (200) and wireless connection for mobile as well as web interface connection. The compartment (100) is such that avoid the direct contact with the medicine. The device (1) also comprising a SoS button (303) being capable to call to the emergency number stored. Fig.1

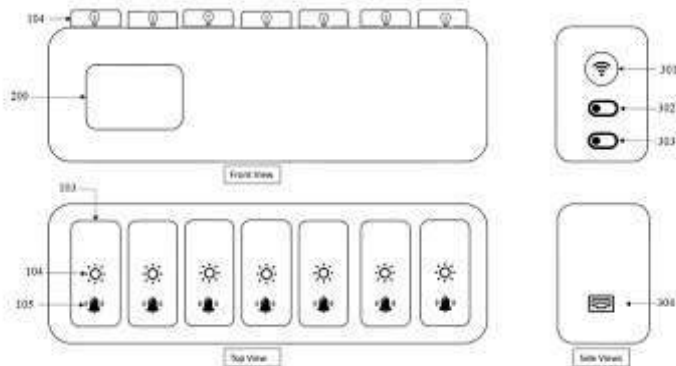

Fig. 1

No. of Pages : 19 No. of Claims : 9

(54) Title of the invention : A MOBILITY DEVICE

(51) International classification :A61G0007100000,
A61G0005040000,
A61G0005140000,
A61G0005000000,
A61G0005100000

(31) Priority Document No :NA
(32) Priority Date :NA
(33) Name of priority country :NA
(86) International Application No :NA
Filing Date :NA
(87) International Publication No : NA
(61) Patent of Addition to Application Number :NA
Filing Date :NA
(62) Divisional to Application Number :NA
Filing Date :NA

(71)Name of Applicant :

1)ALABASTER RESEARCH AND TECHNOLOGIES PRIVATE LIMITED

Address of Applicant :A 603 Himali Tower, NR. Kenyug Appt., NR. Shyamal Cross Road, Satellite, Ahmedabad, Gujarat, India 380015 Gujarat India

(72)Name of Inventor :

1)Chintan Vinod Shinde**2)Aeshna Amin****3)Kishan Amin****4)Prem Shah**

(57) Abstract :

The present disclosure provides a mobility device (100) for moving a person to and from a seated position. The mobility device (100) comprises a seat (2), an adjustable handle (4) and a seat adjusting mechanism (6). The adjustable handle (4) is provided with a first wireless joystick pad (402) for raising, lowering and tilting the seat (2) and for controlling the motion of the device. The seat adjusting mechanism (6) is configured to be attached with said seat (2) and connect with said adjustable handle (4) configured with the first wireless joystick pad (402) to raise, lower and tilt the seat (2). The seat adjusting mechanism (6) comprises a plurality of crossed links (602) pivotally attached with each other, to form the seat adjusting/collapsing mechanism (6) and, an actuating mechanism (604) mounted on a base (8) of the mobility device (100) and linked with the plurality of crossed links (602). [Figure 1]



Figure 1

No. of Pages : 26 No. of Claims : 18

(54) Title of the invention : EMISSION TREATMENT SYSTEM FOR TREATING AN EXHAUST STREAM FROM AN ENGINE

(51) International classification :B01D0053940000,
B01D0053860000,
F01N0003010000,
B03C0003680000,
F01N0003023000

(31) Priority Document No :NA
(32) Priority Date :NA
(33) Name of priority country :NA
(86) International Application No :NA
Filing Date :NA
(87) International Publication No : NA
(61) Patent of Addition to Application Number :NA
Filing Date :NA
(62) Divisional to Application Number :NA
Filing Date :NA

(71)**Name of Applicant :**
1)TATA MOTORS LIMITED
Address of Applicant :Bombay House, 24 Homi Mody Street,
Hutatma Chowk, Mumbai 400 001, Maharashtra, India.
Maharashtra India
**2)TATA MOTORS EUROPEAN TECHNICAL CENTRE
Plc**

(72)**Name of Inventor :**
1)Neil Brison
2)Anthony Ashburner

(57) Abstract :

Embodiments herein provide an emission treatment system (1000) for a vehicle. The emission treatment system (1000) comprises an electrostatic precipitator (100) connected to a titanium oxide catalyst (200). The electrostatic precipitator (100) captures soot particles from an exhaust of the vehicle using a principle of electrostatic precipitation. The titanium oxide catalyst (200) converts nitrogen oxide gas into nitrogen and oxygen. FIG. 2

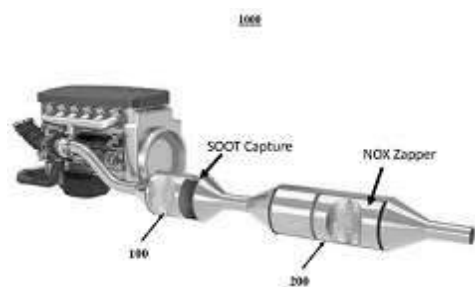

FIG. 2

No. of Pages : 17 No. of Claims : 8

(12) PATENT APPLICATION PUBLICATION

(21) Application No.201921050274 A

(19) INDIA

(22) Date of filing of Application :05/12/2019

(43) Publication Date : 11/06/2021

(54) Title of the invention : A PROCESS FOR PREPARATION OF ROASTED CHICKPEA WITH HERBAL COATING

(51) International classification	:A61K0036185000, A23L0025000000, A61L0033000000, C07K0014415000, A23L0005100000	(71) Name of Applicant : 1)Talwar Bela Madan Address of Applicant :74 - Thankorbhai Tower, Opp. Khadi Sarita, Nr. Law Garden, Ellisbridge, Ahmedabad 380006, Gujarat, India Gujarat India
(31) Priority Document No	:NA	(72) Name of Inventor :
(32) Priority Date	:NA	1)Talwar Bela Madan
(33) Name of priority country	:NA	
(86) International Application No	:NA	
Filing Date	:NA	
(87) International Publication No	: NA	
(61) Patent of Addition to Application Number	:NA	
Filing Date	:NA	
(62) Divisional to Application Number	:NA	
Filing Date	:NA	

(57) Abstract :

A Process For Preparation Of Roasted Chickpea With Herbal Coating The present invention discloses a process of preparation of roasted chickpea with herbal coating which are prepared by roasting the chickpea with herbs. The roasted chickpea are enrobed with a dry mixture of herbal coating agents.

No. of Pages : 15 No. of Claims : 3

(54) Title of the invention : A DEVICE FOR CLEANING WATER BODIES

(51) International classification :C02F0001660000,
C02F0007000000,
C02F0001760000,
E04H0004120000,
C02F0001000000

(31) Priority Document No :NA
(32) Priority Date :NA
(33) Name of priority country :NA
(86) International Application No :NA
Filing Date :NA
(87) International Publication No : NA
(61) Patent of Addition to Application Number :NA
Filing Date :NA
(62) Divisional to Application Number :NA
Filing Date :NA

(71)Name of Applicant :
1)KADGE JATIN NANDKUMAR
Address of Applicant :ROOM NO. 54, CHAWL NO. 2, OLD
B.D.D. CHAWL, S.S. WAUGH ROAD, NAIGAON, DADAR,
MUMBAI - 400014, MAHARASHTRA, INDIA. Maharashtra
India
(72)Name of Inventor :
1)KADGE JATIN NANDKUMAR

(57) Abstract :
An eco-friendly and economical remotely operatable device for cleaning garbage including microplastic from water bodies. The device can be remotely operated wirelessly within a range of 20-1000 meters radius and is used for collecting the garbage that floats on the surface water column.

Fig. 1

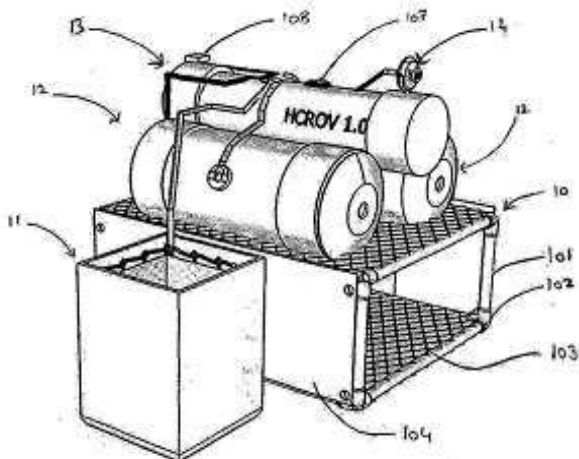

No. of Pages : 19 No. of Claims : 9

(54) Title of the invention : METHOD AND SYSTEM FOR FACILITATING SCHEDULED TRANSACTIONS

<p>(51) International classification :G06Q0020400000, G06Q0020320000, G06Q0020100000, G06Q0050220000, H04W0072120000</p> <p>(31) Priority Document No :NA (32) Priority Date :NA (33) Name of priority country :NA (86) International Application No :NA Filing Date :NA (87) International Publication No : NA (61) Patent of Addition to Application Number :NA Filing Date :NA (62) Divisional to Application Number :NA Filing Date :NA</p>	<p>(71)Name of Applicant : 1)MASTERCARD INTERNATIONAL INCORPORATED Address of Applicant :2000 Purchase Street, Purchase, NY 10577 U.S.A.</p> <p>(72)Name of Inventor : 1)Ritesh Chaudhari 2)Chetan Bhalerao 3)Arpan Beohar 4)Ashish Dhande</p>
--	---

(57) Abstract :

A method and system for facilitating payment transactions is provided. A server receives a transaction scheduling request from a first user device for scheduling a payment transaction from a first payment account associated with a first user to a second payment account associated with a second user. The payment transaction is scheduled for a first time instance. Upon successful scheduling of the payment transaction, a one-time password for authenticating the scheduled payment transaction is communicated to the first user. The server receives a payment transaction request corresponding to the scheduled payment transaction from a second user device associated with the second user to approve the scheduled payment transaction. The scheduled payment transaction is approved upon successfully receiving the one-time password from the second user device.

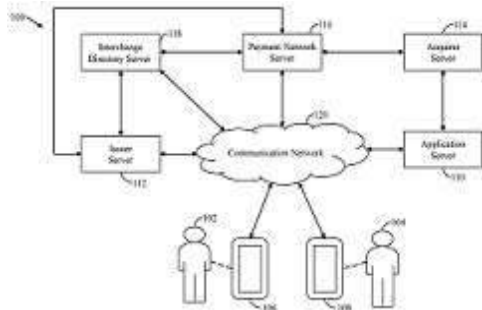

FIG. 1

No. of Pages : 70 No. of Claims : 20

(12) PATENT APPLICATION PUBLICATION

(21) Application No.201921050387 A

(19) INDIA

(22) Date of filing of Application :06/12/2019

(43) Publication Date : 11/06/2021

(54) Title of the invention : DEVELOPMENT OF NOVEL PRESSURISED SOLID-LIQUID EXTRACTOR FOR NATURAL PRODUCTS AND HERBAL DYE'S EXTRACTION.

(51) International classification	:B01D0011020000, B01F0015040000, D06P0001340000, A61K0036185000, C11B0009020000	(71)Name of Applicant : 1)Dr.Pravinkumar Patil Address of Applicant :DOT, Shivaji University, kolhapur Maharashtra India 2)Dr.Akilahemad Wasif 3)RISHABH HATTIMARE
(31) Priority Document No	:NA	(72)Name of Inventor :
(32) Priority Date	:NA	1)Dr.Pravinkumar Patil
(33) Name of priority country	:NA	2)Dr.Akilahemad Wasif
(86) International Application No	:NA	3)RISHABH HATTIMARE
Filing Date	:NA	
(87) International Publication No	: NA	
(61) Patent of Addition to Application Number	:NA	
Filing Date	:NA	
(62) Divisional to Application Number	:NA	
Filing Date	:NA	

(57) Abstract :

In the present investigation, the extraction of natural dyes is done by heating its raw material with an appropriate solvent and it leads to the separation of pivotal color pigments from its raw matter. This novel invention describes the technique for efficient extraction of the active constituents from vegetable based fine solid powdered raw material using liquid solvent and pneumatic technique. The extractor mainly works on the principle of changing pressure gradients i.e. positive and negative pressure gradients, through the bed of solid material housed in the cartridges. Further, due to repetition of the cycles of negative and positive pressures applied pneumatically with a cylinder piston air compressor setup, the entire extraction of the target component from solid raw material is done in lesser time than other methods used for extraction even at the room temperature.

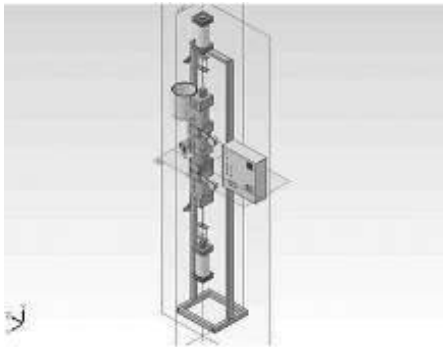

No. of Pages : 27 No. of Claims : 1

(12) PATENT APPLICATION PUBLICATION

(21) Application No.201921050399 A

(19) INDIA

(22) Date of filing of Application :06/12/2019

(43) Publication Date : 11/06/2021

(54) Title of the invention : SELF VENTILATING SUSTAINABLE BUILDING

(51) International classification	:G03G0009087000, C08G0018750000, C11D0001290000, F03D0009340000, D21H0017670000	(71) Name of Applicant : 1)Tanishka Abhijit Shah Address of Applicant :1008, Tower 2, Gera Trinity Towers, Gera™s Greensville, Kharadi, Pune - 411014, Maharashtra, India Maharashtra India
(31) Priority Document No	:NA	(72) Name of Inventor :
(32) Priority Date	:NA	1)Tanishka Abhijit Shah
(33) Name of priority country	:NA	
(86) International Application No	:NA	
Filing Date	:NA	
(87) International Publication No	: NA	
(61) Patent of Addition to Application Number	:NA	
Filing Date	:NA	
(62) Divisional to Application Number	:NA	
Filing Date	:NA	

(57) Abstract :

SELF VENTILATING SUSTAINABLE BUILDING Abstract Disclosed is a self ventilating sustainable building (100) that comprises a day-lighting arrangement, a water distribution system and a ventilation system. The material used for the construction of the self ventilating sustainable building (100) is a self-cement that reduces the carbon emission by fixation of CO₂ during the processing and creation of the material. The self ventilating sustainable building (100) is designed in such a way that the requirement of air conditioners and fans is completely eliminated and the overall energy consumption of the self ventilating sustainable building (100) is far less than a normal building. Figure 6



No. of Pages : 19 No. of Claims : 7

(54) Title of the invention : AN EXHAUST SYSTEM FOR AN INTERNAL COMBUSTION ENGINE

(51) International classification :F01N0003280000,
B01F0003040000,
F01N0013000000,
F01N0013180000,
B01F0005000000

(31) Priority Document No :NA
(32) Priority Date :NA
(33) Name of priority country :NA
(86) International Application No :NA
Filing Date :NA
(87) International Publication No : NA
(61) Patent of Addition to Application Number:NA
Filing Date :NA
(62) Divisional to Application Number :NA
Filing Date :NA

(71)**Name of Applicant :**
1)FAURECIA INDIA PRIVATE LIMITED
Address of Applicant :Plot No.T-187, Pimpri Industrial Area
(B.G. Block), Behind Bhosari Police Station, Bhosari, Pune,
411026 MH. India Maharashtra India

(72)**Name of Inventor :**
1)AHMED, Aejaz

(57) Abstract :

The present invention is to provide an exhaust system 500 for an internal combustion engine. The exhaust system 500 includes an inlet pipe 100, an after treatment unit 200, and an outlet pipe 300. The inlet pipe 100 includes an upper portion 110, a middle portion 120 and a lower portion 130. The upper portion 110 and the lower portion 130 has perforations for directing and guiding the exhaust gas flow towards an after-treatment unit 200. Further, the middle portion 120 of the inlet pipe 100 has a reduced cross sectional area than the upper portion 110 and the lower portion 130 which facilitates a uniform flow distribution of exhaust gas towards the after treatment unit 200. The present invention enhances enough swirl/turbulence for the exhaust flow entering the exhaust system 500 such that flow distribution over a substrate 210 face is uniform, especially for radial inlet systems. Figure 1

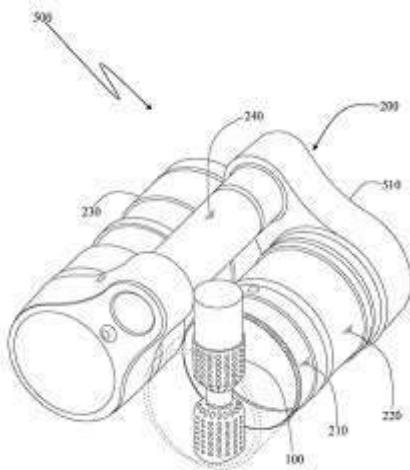

Figure 1

No. of Pages : 18 No. of Claims : 6

(54) Title of the invention : VANE TYPE SEPARATOR WITH ENHANCED PERFORMANCE

(51) International classification	:B01D0045080000, B01D0050000000, F01D0005180000, F02C0003040000, F01M0013040000	(71)Name of Applicant : 1)LARSEN & TOUBRO LIMITED Address of Applicant :L&T House, Ballard Estate, Mumbai - 400 001, Maharashtra State, India Maharashtra India
(31) Priority Document No	:NA	(72)Name of Inventor :
(32) Priority Date	:NA	1)Murur Venkatesh
(33) Name of priority country	:NA	2)Suyog Shinde
(86) International Application No	:NA	
Filing Date	:NA	
(87) International Publication No	: NA	
(61) Patent of Addition to Application	:NA	
Number	:NA	
Filing Date	:NA	
(62) Divisional to Application Number	:NA	
Filing Date	:NA	

(57) Abstract :

Disclosed is a vane type separator for separating liquid droplets from steam-liquid or gas-liquid mixture. The vane type separator comprising a stack of plurality of vanes closely arranged together to form a plurality of flow path for stream of steam/gas-mist mixture. Specifically each vane of the plurality vanes includes multiple bends to form any one of wave and saw tooth shaped flow paths. The vane type separator is characterized by that the flow path is divided into two equal channels by using a partition plate. The vane type liquid separator works with a principle of inertial impaction for the mist elimination by employing closely arranged separation surfaces forming a wave or saw tooth shaped flow paths and variable gaps between two surfaces along the flow path to achieve more efficiency with the progression of the flow passage.

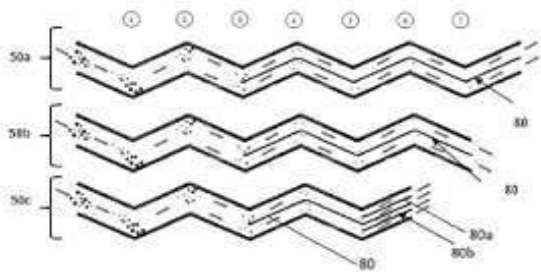

Figure 4

No. of Pages : 13 No. of Claims : 5

(54) Title of the invention : SCRAPER GATE MECHANISM

(51) International classification :E01C0023088000,
E02F0003650000,
E02F0003640000,
A01K0001020000,
E05F0015530000

(31) Priority Document No :NA
(32) Priority Date :NA
(33) Name of priority country :NA
(86) International Application No :NA
Filing Date :NA
(87) International Publication No : NA
(61) Patent of Addition to Application Number:NA
Filing Date :NA
(62) Divisional to Application Number :NA
Filing Date :NA

(71)**Name of Applicant :**
1)LARSEN & TOUBRO LIMITED
Address of Applicant :L&T House, Ballard Estate, Mumbai -
400 001, Maharashtra State, India Maharashtra India

(72)**Name of Inventor :**
1)Talaviya Manish Mansukhbhai
2)Logesh Ranganathan
3)Arumugam Gomathinayagam

(57) Abstract :

Disclosed is a scraper gate mechanism (50) for a scraper gate (60) of a milling unit (100) of a milling machine. The scraper gate mechanism (50) comprises a hinged plate (10), an actuator (20), a sliding plate (30) and a pair of guide rods (40). The scraper gate (60) is fully opened by removing a locking pin from one of the hinge (6) and partially opened by adjusting the height of the sliding plate (30) that is controlled and guided by the actuator (20) and the pair of guide rods (40). The scraper gate mechanism (50) allows access to a plurality of cutter picks (75) when an engine is switched off without a hydraulic power. The scraper gate mechanism (50) allows partial opening of the scraper gate (60) that result in a lesser stroke length of the actuator (20) and hence better space utilization and lesser costs

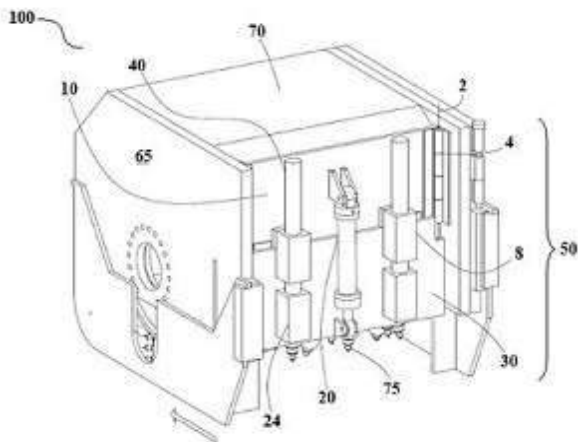

Figure 3

No. of Pages : 16 No. of Claims : 4

(54) Title of the invention : WIRELESS COMMAND OPERATED DETONATOR FOR LANDMINE DEMOLITION

(51) International classification :E04G0023080000,
F42B0003113000,
E02F0003960000,
F42D0001055000,
A61B0017000000

(31) Priority Document No :NA
(32) Priority Date :NA
(33) Name of priority country :NA
(86) International Application No :NA
Filing Date :NA
(87) International Publication No : NA
(61) Patent of Addition to Application Number :NA
Filing Date :NA
(62) Divisional to Application Number :NA
Filing Date :NA

(71)**Name of Applicant :**
1)Aerobotics7 Inventions Private Limited
Address of Applicant :A/131/FF-Indraprakash C.H.S.L., Opp.
Indrajit Society, Nr. Diamond Mill, Nicol Road, Ahmedabad
Gujarat India
(72)**Name of Inventor :**
1)Harshwardhansinh Zala

(57) Abstract :

The present invention is a truly wireless method of sending the secure signals from the base to the wireless detonator for the explosion. The Detonator is having many functionalities including wireless command based controlling function, easy platform adaption as per the needs and the capability of using multiple explosives. The Main Purpose of this system is for Landmines Demolition, utilized with a drone/UAV or any other Mechanical devices. It is very lightweight and can be used for controlling multiple systems at once.

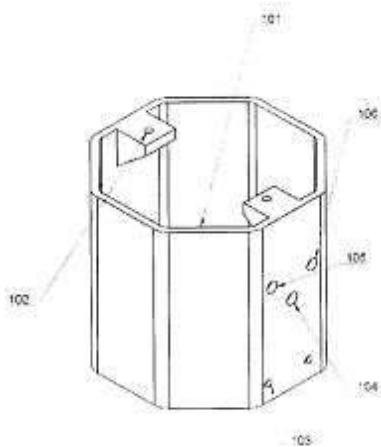

Fig 1

No. of Pages : 17 No. of Claims : 12

(54) Title of the invention : MULTISPECTRUM BASED LANDMINES DISCOVERY & ACCURATE IDENTIFICATION

(51) International classification	:G11B0007095000, G01N0033680000, H04W0048160000, G06F0003034600, G06F0003048100	(71) Name of Applicant : 1)Aerobotics7Inventions Private Limited Address of Applicant :A/131/FF-Indraprakash C.H.S.L., Opp. Indrajit Society, Nr. Diamond Mill, Nicol Road, Ahmedabad Gujarat India
(31) Priority Document No	:NA	(72) Name of Inventor :
(32) Priority Date	:NA	1)Harshwardhansinh Zala
(33) Name of priority country	:NA	
(86) International Application No	:NA	
Filing Date	:NA	
(87) International Publication No	: NA	
(61) Patent of Addition to Application Number	:NA	
Filing Date	:NA	
(62) Divisional to Application Number	:NA	
Filing Date	:NA	

(57) Abstract :

Landmine Explosives are one of the major issues and deadliest of all times across the globe. It has been considered as a highly non-detectable object and having the highest risk of human lives. It is very complex and time-consuming technique as well. Multiple-Spectrum based Landmines Discovery & Accurate Identification is a method and technique of the highly accurate and capable of detecting & identifying the less-detectable Landmines buried on Earth. This method utilizes the Multiple-Spectrum based Signal Generating and Transmitting the Algorithm driven waves. Then it uses the different designs of the signal amplifying, filtering, pre-processing, post-processing, mixing, analyzing and outputting on different human recognizable outputs.

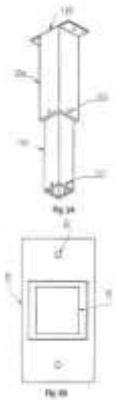

No. of Pages : 27 No. of Claims : 18

(54) Title of the invention : STRETCHABLE BEDDING COMPONENTS

(51) International classification :A47G0009020000,
B32B0007120000,
A47C0031100000,
A41D0007000000,
G06F0015780000

(31) Priority Document No :NA
(32) Priority Date :NA
(33) Name of priority country :NA
(86) International Application No :NA
Filing Date :NA
(87) International Publication No : NA
(61) Patent of Addition to Application Number :NA
Filing Date :NA
(62) Divisional to Application Number :NA
Filing Date :NA

(71)**Name of Applicant :**
1)INDO COUNT INDUSTRIES LTD.
Address of Applicant :301, 3RD FLOOR, ARCADIA BUILDING, NARIMAN POINT, MUMBAI-400021, INDIA.
Maharashtra India

(72)**Name of Inventor :**
1)JAIN, Mohit Kumar

(57) Abstract :

Stretchable bedding components reconfigurable between a neutral or retracted configuration and an expanded configuration. In example embodiments, fabric is cut and sewn to form one or more bedding components with at least some dimensions being about 5% - 30% less than those of conventional or traditional bedding components. In example embodiments, the length and/or width of the bedding component is expandable between about 5% - 30%. In example embodiments, the stretchable bedding components include a biocomponent yarn having a helical structure that imparts elasticity therein so as to permit stretching of the one or more bedding components.

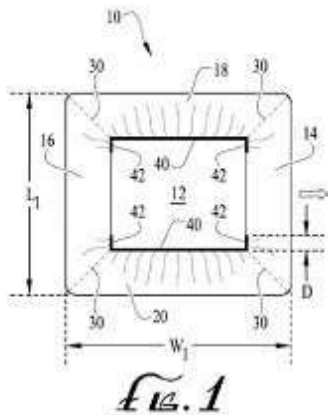

No. of Pages : 35 No. of Claims : 26

(54) Title of the invention : BETA ROBOT.

(51) International classification :B25J0009160000,
B25J0009040000,
B25J0009000000,
B25J0009100000,
B25J0017020000

(31) Priority Document No :NA
(32) Priority Date :NA
(33) Name of priority country :NA
(86) International Application No :NA
Filing Date :NA
(87) International Publication No : NA
(61) Patent of Addition to Application Number :NA
Filing Date :NA
(62) Divisional to Application Number :NA
Filing Date :NA

(71)Name of Applicant :

1)Shubham Sachin Sonigra

Address of Applicant :Shubham Sachin Sonigra, residing at E-202, Park Royale, Rahatani, Pune 411017, Maharashtra, India, An Indian National. Maharashtra India

2)Ganesh Dnyandeo Dudhe

(72)Name of Inventor :

1)Shubham Sachin Sonigra

(57) Abstract :

In this invention, I have developed a new type to robot called as Beta Robot which can used for industrial automation needs like high speed pick and place and where size of the robot and cost of the robot play an important role. This robot is a 3-Degree of Freedom system. The Beta Robot is mounted vertically on the ceiling in such a way that the body of the robot comes directly above the working area. This robot has three servo motors with gearboxes for the three axes. The first axis is a serial axis and the next two axes are parallel axes. These servo motors are standard industrial servo motors attached to high precision gearboxes. The servo motors are controlled by PLC in which the forward kinematics and inverse kinematics are programmed. The synchronized motion of two parallel axes and one serial axis leads to a proper positioning of the end effector. The invention also specifies the placement of the axes for the optimum functioning of the Beta Robot. The design of motor mounting specified by this invention is crucial for the proper functioning of the robot.

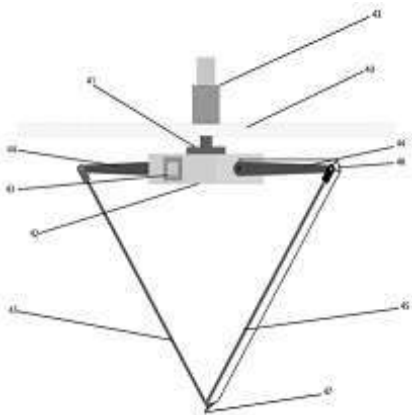

No. of Pages : 18 No. of Claims : 6

(54) Title of the invention : A METHOD OF PULSED POWER TRANSMISSION AND SYSTEM THEREOF

(51) International classification :F16H0055360000,
F03G0007100000,
H02K0016000000,
B60K0006547000,
F16H0003000000

(31) Priority Document No :NA
(32) Priority Date :NA
(33) Name of priority country :NA
(86) International Application No :NA
Filing Date :NA
(87) International Publication No : NA
(61) Patent of Addition to Application Number:NA
Filing Date :NA
(62) Divisional to Application Number :NA
Filing Date :NA

(71)**Name of Applicant :**
1)SAURABH VIKAS CHAUDHARI
Address of Applicant :SAURABH VIKAS CHAUDHARI.
Indian S/O Vikas Kisan Chaudhari. H/N. 1341, Near
Swaminarayan Temple, Savda. Taluka: Raver, Distt.: Jalgaon.
Maharashtra 425 502 Maharashtra India

(72)**Name of Inventor :**
1)SAURABH VIKAS CHAUDHARI

(57) Abstract :

A pulsed power transmission system and method are completely different from the conventional continuous power transmission we are using today. A pulsed power transmission system comprises a said prime mover 101 connected to an input shaft 102 connected to at most two output shafts 110 through said intermittent power transmitting mechanism, wherein each of the output shaft 110 is connected to a said power receiving object 108, an arrangement is made such that at least one rotational energy-storing mechanical component is mounted on or connected to each output shaft 110 and input shaft 102.

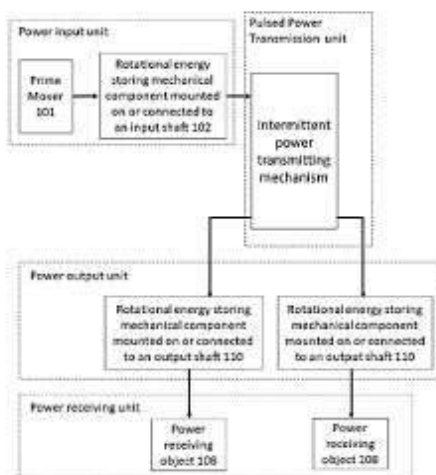

FIG. 4

No. of Pages : 33 No. of Claims : 18

(54) Title of the invention : ALGORITHM AND COMPUTER PROGRAM TO PREDICATE THE PRICE OF NATURAL GAS USING CORRELATION COEFFICIENT OF PRICE OF NATURAL GAS AND TEMPERATURE.

(51) International classification :G01K0007420000,
F01N0011000000,
C10L0003100000,
G06F0012086200,
G06Q0010040000

(31) Priority Document No :NA
(32) Priority Date :NA
(33) Name of priority country :NA
(86) International Application No :NA
Filing Date :NA
(87) International Publication No : NA
(61) Patent of Addition to Application Number :NA
Filing Date :NA
(62) Divisional to Application Number :NA
Filing Date :NA

(71)**Name of Applicant :**
1)MESBRO TECHNOLOGIES PRIVATE LIMITED
Address of Applicant :Flat no C/904, Geomatrix Dev, Plot no 29, Sector 25, Kamothe, Raigarh-410209, Maharashtra, India
Maharashtra India

(72)**Name of Inventor :**
1)Mr. Bhaskar Vijay Ajaonkar

(57) Abstract :

The algorithm is used to predict the price of natural gas in near future. For this prediction it uses data of temperature and price of natural gas for that particular temperature for particular cities with reference to correlation coefficient of natural gas price. For efficient prediction it will use data of temperature prediction from multiple agencies. And then it will take mean of temperature for particular city. By comparing price of natural gas in near future to current price of natural gas it will advise for import or export of natural gas.

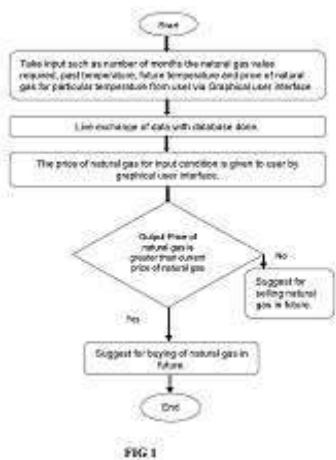

No. of Pages : 11 No. of Claims : 5

(54) Title of the invention : A SYSTEM FOR PLATFORM GAMES USING ARTIFICIAL INTELLIGENCE •

<p>(51) International classification :G06Q0010060000, A63F0013400000, G07C0005000000, A63F0013800000, G06Q0010000000</p> <p>(31) Priority Document No :NA</p> <p>(32) Priority Date :NA</p> <p>(33) Name of priority country :NA</p> <p>(86) International Application No :NA Filing Date :NA</p> <p>(87) International Publication No : NA</p> <p>(61) Patent of Addition to Application Number :NA Filing Date :NA</p> <p>(62) Divisional to Application Number :NA Filing Date :NA</p>	<p>(71)Name of Applicant : 1)MESBRO TECHNOLOGIES PRIVATE LIMITED Address of Applicant :Flat no C/904, Geomatrix Dev, Plot no 29, Sector 25, Kamothe, Raigarh-410209, Maharashtra, India Maharashtra India</p> <p>(72)Name of Inventor : 1)Mr. Bhaskar Vijay Ajgaonkar</p>
---	--

(57) Abstract :

Accordingly, a system for platform games using artificial intelligence is disclosed. A system for platform games using artificial intelligence comprising of; Finding out a solution for platform games using player experienced modelling; Evaluating quality of each solution and comparing the solutions; Omitting the worst quality solutions; Operating the solutions through various commands like move right, move left, move up, move down, jump etc and Allowing the website of the database to assess any textual messages or documents sent by the player automatically in a meaningful way

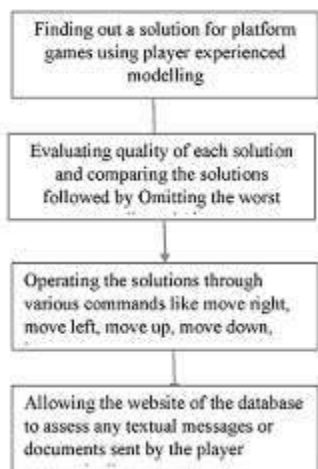

FIG 1

No. of Pages : 8 No. of Claims : 3

(54) Title of the invention : SYSTEM FOR EFFECTIVE CONTROLLING OF TRAFFIC MANAGEMENT •

<p>(51) International classification</p> <p>(31) Priority Document No</p> <p>(32) Priority Date</p> <p>(33) Name of priority country</p> <p>(86) International Application No Filing Date</p> <p>(87) International Publication No</p> <p>(61) Patent of Addition to Application Number Filing Date</p> <p>(62) Divisional to Application Number Filing Date</p>	<p>:G08G0001070000, G08G0001080000, G08G0001010000, G08G0001015000, G01N0021956000</p> <p>:NA</p> <p>:NA</p> <p>:NA</p> <p>:NA</p> <p>: NA</p> <p>:NA</p> <p>:NA</p> <p>:NA</p> <p>:NA</p> <p>:NA</p>	<p>(71)Name of Applicant : 1)MESBRO TECHNOLOGIES PRIVATE LIMITED Address of Applicant :Flat no C/904, Geomatrix Dev, Plot no 29, Sector 25, Kamothe, Raigarh-410209, Maharashtra, India Maharashtra India</p> <p>(72)Name of Inventor : 1)Mr. Bhaskar Vijay Ajsaonkar</p>
--	---	---

(57) Abstract :

Accordingly, a system for effective controlling of traffic management is disclosed. A system for effective controlling of traffic management comprising of; Detecting the traffic through traffic cameras; Automatically detecting the number of road users, including pedestrians, and types of vehicles that are at an intersection through video feeds; Detecting ways to move traffic through the intersection, changing traffic lights depending on the most optimal way of keeping traffic moving; Gathering all the information in the database of the website; Analyzing data and Enabling computers to identify, process and interpret visual data; and Notifying the user about the status of the traffic and visualize the traffic diversions needed.

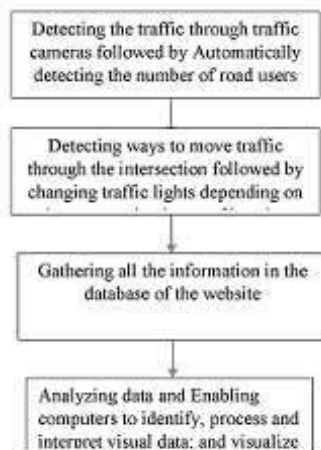

FIG 1

No. of Pages : 10 No. of Claims : 6

(54) Title of the invention : SYSTEMS AND METHODS FOR BLOCKCHAIN-BASED RESTORATIVE INFORMATION TRANSMISSION

(51) International classification	:H04L0009320000, G06Q0020380000, G06Q0020060000, A63B0069360000, H04L0005000000	(71) Name of Applicant : 1)MESBRO TECHNOLOGIES PRIVATE LIMITED Address of Applicant :Flat no C/904, Geomatrix Dev, Plot no 29, Sector 25, Kamothe, Raigarh-410209, Maharashtra, India Maharashtra India
(31) Priority Document No	:NA	(72) Name of Inventor :
(32) Priority Date	:NA	1)Mr. Bhaskar Vijay Ajsaonkar
(33) Name of priority country	:NA	
(86) International Application No	:NA	
Filing Date	:NA	
(87) International Publication No	: NA	
(61) Patent of Addition to Application Number	:NA	
Filing Date	:NA	
(62) Divisional to Application Number	:NA	
Filing Date	:NA	

(57) Abstract :

The system and method identifies with a program for blockchain-based therapeutic information transmission with improved security. The method for blockchain-based medicinal information transmission includes the means of: accepting, by a hand-off server, at least one bits of square information from a first hub server; consolidating, by the hand-off server, the at least one bits of square information with a blockchain and putting away the equivalent; and transmitting the at least one bits of square information to a second hub server. As indicated by the present invention, it is conceivable to check whether therapeutic information, for which a transmission demand has been made by a client, is fashioned or adulterated, by looking at square information put away in a majority of hub servers, and in this way it is conceivable to transmit, to an ideal hub server, the first information that isn't produced or misrepresented.

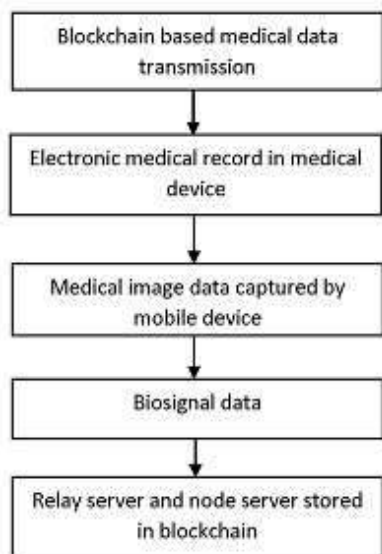

Fig: 1

No. of Pages : 10 No. of Claims : 3

(54) Title of the invention : SYSTEMS AND METHODS FOR BLOCKCHAIN-BASED INFORMATION MANAGEMENT •

(51) International classification	:H04L0029060000, H04L0009320000, G06F0021310000, G06Q0020380000, G06F0021640000	(71) Name of Applicant : 1)MESBRO TECHNOLOGIES PRIVATE LIMITED Address of Applicant :Flat no C/904, Geomatrix Dev, Plot no 29, Sector 25, Kamothe, Raigarh-410209, Maharashtra, India Maharashtra India
(31) Priority Document No	:NA	(72) Name of Inventor :
(32) Priority Date	:NA	1)Mr. Bhaskar Vijay Ajgaonkar
(33) Name of priority country	:NA	
(86) International Application No	:NA	
Filing Date	:NA	
(87) International Publication No	: NA	
(61) Patent of Addition to Application Number	:NA	
Filing Date	:NA	
(62) Divisional to Application Number	:NA	
Filing Date	:NA	

(57) Abstract :

Methods Systems, and equipment, as well as laptop programs encoded on computer memory media, for playacting knowledge management. one among the strategies includes: getting authentication data of a login user; generating a digital abstract of the authentication information of the login user; and authenticating the login user supported a comparison between the digital abstract of the authentication information of the login user and one or additional digital abstracts keep on a blockchain.

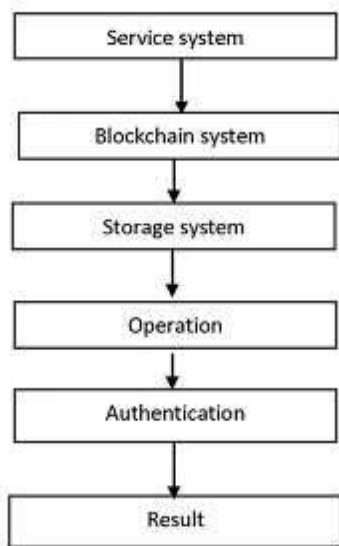

Fig: 1

No. of Pages : 11 No. of Claims : 4

(12) PATENT APPLICATION PUBLICATION

(21) Application No.201921050588 A

(19) INDIA

(22) Date of filing of Application :07/12/2019

(43) Publication Date : 11/06/2021

(54) Title of the invention : A SYSTEM FOR EVALUATING PATENT USING ARTIFICIAL INTELLIGENCE •

(51) International classification	:G06Q0050180000, G06Q0050160000, G06Q0010100000, G06F0016330000, E21B0047000000	(71)Name of Applicant : 1)MESBRO TECHNOLOGIES PRIVATE LIMITED Address of Applicant :Flat no C/904, Geomatrix Dev, Plot no 29, Sector 25, Kamothe, Raigarh-410209, Maharashtra, India Maharashtra India
(31) Priority Document No	:NA	(72)Name of Inventor :
(32) Priority Date	:NA	1)Mr. Bhaskar Vijay Ajsaonkar
(33) Name of priority country	:NA	
(86) International Application No	:NA	
Filing Date	:NA	
(87) International Publication No	: NA	
(61) Patent of Addition to Application Number	:NA	
Filing Date	:NA	
(62) Divisional to Application Number	:NA	
Filing Date	:NA	

(57) Abstract :

Accordingly, a system for patent evaluation which will choose correct parameters for evaluation of patent is disclosed. A system for patent evaluation using artificial intelligence comprising of; A computer/desktop/laptop for evaluating a patent document; A data input means for receiving data with respect to patents , showing quality of the patent and monetary value of patent; A computer processor for analyzing the patent data ; and A quality checking unit for determining quality of the patent document for generating a conclusion regarding the quality of the patent document ; Wherein the data input means or data storage means such as internal database of the website for receiving data with respect to patents.



No. of Pages : 9 No. of Claims : 6

(54) Title of the invention : A SYSTEM FOR IMPROVING CROP PRODUCTIVITY •

(51) International classification	:G06Q0010060000, A01B0079000000, G06Q0050020000, A01G0007000000, B64C0039020000	(71) Name of Applicant : 1)MESBRO TECHNOLOGIES PRIVATE LIMITED Address of Applicant :Flat no C/904, Geomatrix Dev, Plot no 29, Sector 25, Kamothe, Raigarh-410209, Maharashtra, India Maharashtra India
(31) Priority Document No	:NA	(72) Name of Inventor :
(32) Priority Date	:NA	1)Mr. Bhaskar Vijay Ajgaonkar
(33) Name of priority country	:NA	
(86) International Application No	:NA	
Filing Date	:NA	
(87) International Publication No	: NA	
(61) Patent of Addition to Application Number	:NA	
Filing Date	:NA	
(62) Divisional to Application Number	:NA	
Filing Date	:NA	

(57) Abstract :

Accordingly, a system for improving crop management practices is disclosed. A system for improving agricultural productivity comprising of; Creating seasonal forecasting models; Carrying out farm monitoring on registration by the farmer in the internal database of the website; Utilizing drones for flying on fields; Capturing the images of the entire farm through the cameras using artificial intelligence; Analyzing the images for identifying problem areas through computer network; Collecting all the data of soil sampling using sensors; and Detecting the weeds and deciding the type of herbicide application.

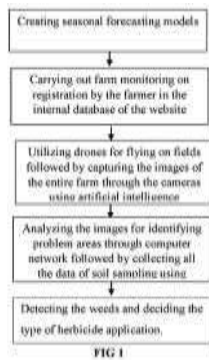

FIG 1

No. of Pages : 11 No. of Claims : 4

(54) Title of the invention : A SYSTEM FOR DIGITAL VOTING USING BLOCKCHAIN TECHNOLOGY •

<p>(51) International classification</p> <p>(31) Priority Document No</p> <p>(32) Priority Date</p> <p>(33) Name of priority country</p> <p>(86) International Application No</p> <p style="padding-left: 20px;">Filing Date</p> <p>(87) International Publication No</p> <p>(61) Patent of Addition to Application Number</p> <p style="padding-left: 20px;">Filing Date</p> <p>(62) Divisional to Application Number</p> <p style="padding-left: 20px;">Filing Date</p>	<p>:H04L0009320000, H04L0029060000, G07C0013000000, G06F0021640000, G06Q0020060000</p> <p>:NA</p> <p>:NA</p> <p>:NA</p> <p>:NA</p> <p>:NA</p> <p>:NA</p> <p>:NA</p> <p>:NA</p> <p>:NA</p> <p>:NA</p> <p>:NA</p> <p>:NA</p> <p>:NA</p> <p>:NA</p>	<p>(71)Name of Applicant : 1)MESBRO TECHNOLOGIES PRIVATE LIMITED Address of Applicant :Flat no C/904, Geomatrix Dev, Plot no 29, Sector 25, Kamothe, Raigarh-410209, Maharashtra, India Maharashtra India</p> <p>(72)Name of Inventor : 1)Mr. Bhaskar Vijay Ajgaonkar</p>
---	--	---

(57) Abstract :

Accordingly, a system digital voting using block chain technology is disclosed. The present invention helps providing security and integrity. A system for digital voting using block chain technology comprising of; Registering the user in the internal database of the website; verification unit for Verifying the voter; Receiving acknowledgement data to the voter; altering the verification data using the acknowledgement data received from the voter; and analyzer unit for Analyzing automated government miner the transaction.



No. of Pages : 9 No. of Claims : 3

(12) PATENT APPLICATION PUBLICATION

(21) Application No.201921050592 A

(19) INDIA

(22) Date of filing of Application :07/12/2019

(43) Publication Date : 11/06/2021

(54) Title of the invention : A SYSTEM FOR CUSTOMER SERVICE USING ARTIFICIAL INTELLIGENCE •

(51) International classification	:G06Q0030000000, H04M0003510000, G06N0005040000, G06N0003000000, H04M0003493000	(71) Name of Applicant : 1)MESBRO TECHNOLOGIES PRIVATE LIMITED Address of Applicant :Flat no C/904, Geomatrix Dev, Plot no 29, Sector 25, Kamothe, Raigarh-410209, Maharashtra, India Maharashtra India
(31) Priority Document No	:NA	(72) Name of Inventor :
(32) Priority Date	:NA	1)Mr. Bhaskar Vijay Ajgaonkar
(33) Name of priority country	:NA	
(86) International Application No	:NA	
Filing Date	:NA	
(87) International Publication No	: NA	
(61) Patent of Addition to Application Number	:NA	
Filing Date	:NA	
(62) Divisional to Application Number	:NA	
Filing Date	:NA	

(57) Abstract :

Accordingly, a system for customer service operations using artificial intelligence is disclosed. The system for customer service operations using artificial intelligence comprising of; Analyzing unit for analyzing customer interaction with the website; Analyzing whether automated response system responded to the customer interaction or not; Intimating the living agent about disabling of the automated response system; Sending customer message using the network chat messaging system.



FIG. 1

No. of Pages : 9 No. of Claims : 3

(54) Title of the invention : SYSTEMS AND METHODS FOR UTILIZING CODES AND PICTURES INSIDE A BLOCKCHAIN •

(51) International classification	:G06Q0030060000, G06Q0010080000, H04L0009320000, G06Q0030000000, G06Q0050000000	(71) Name of Applicant : 1)MESBRO TECHNOLOGIES PRIVATE LIMITED Address of Applicant :Flat no C/904, Geomatrix Dev, Plot no 29, Sector 25, Kamothe, Raigarh-410209, Maharashtra, India Maharashtra India
(31) Priority Document No	:NA	(72) Name of Inventor :
(32) Priority Date	:NA	1)Mr. Bhaskar Vijay Ajgaonkar
(33) Name of priority country	:NA	
(86) International Application No	:NA	
Filing Date	:NA	
(87) International Publication No	: NA	
(61) Patent of Addition to Application Number	:NA	
Filing Date	:NA	
(62) Divisional to Application Number	:NA	
Filing Date	:NA	

(57) Abstract :

Systems and methods enable clients to check the credibility or provenance of physical items before buying or getting physical articles. The methods include examining a code of or an example implanted or fused in a physical article in travel or upon creation, transmitting the checked code and data of the physical item through the Web, producing or refreshing a square dependent on the filtered code and the data, confirming or verifying the square, and putting away the square as a changeless piece of a disseminated record. The code or example is a one of a kind identifiers of the physical item. The methods may incorporate catching a picture of the physical item or an article related with the physical item to be utilized for auxiliary check and creating or refreshing the square in order to remember the acquired picture for the square of the blockchain.



Fig 1

No. of Pages : 11 No. of Claims : 3

(12) PATENT APPLICATION PUBLICATION

(21) Application No.201921050594 A

(19) INDIA

(22) Date of filing of Application :07/12/2019

(43) Publication Date : 11/06/2021

(54) Title of the invention : A SYSTEM FOR TRACKING PRESCRIPTION MEDICINES •

(51) International classification	:G06Q0050220000, G06Q0010080000, G07F0017000000, G06Q0010100000, G16H0040200000	(71) Name of Applicant : 1)MESBRO TECHNOLOGIES PRIVATE LIMITED Address of Applicant :Flat no C/904, Geomatrix Dev, Plot no 29, Sector 25, Kamothe, Raigarh-410209, Maharashtra, India Maharashtra India
(31) Priority Document No	:NA	(72) Name of Inventor :
(32) Priority Date	:NA	1)Mr. Bhaskar Vijay Ajgaonkar
(33) Name of priority country	:NA	
(86) International Application No	:NA	
Filing Date	:NA	
(87) International Publication No	: NA	
(61) Patent of Addition to Application Number	:NA	
Filing Date	:NA	
(62) Divisional to Application Number	:NA	
Filing Date	:NA	

(57) Abstract :

A system for tracking prescription medicines between two locations and an inventory of prescription medication at a location comprising of; Generating prescription labels for the prescription orders; Storing prescription data in the internal database of the website on user computer; Scanning the prescription labels after the medication containers have been filled followed by sorting each respective healthcare facility; Comparing the data to the stored prescription data to verify prescriptions; and updating the database with the prescription data.



No. of Pages : 9 No. of Claims : 3

(12) PATENT APPLICATION PUBLICATION

(21) Application No.201921050595 A

(19) INDIA

(22) Date of filing of Application :07/12/2019

(43) Publication Date : 11/06/2021

(54) Title of the invention : SYSTEMS AND METHODS FOR ONLINE COORDINATED EFFORT IN NETWORKING CONDITIONS •

(51) International classification	:G06F0003048200, G01B0011250000, H04N0013398000, G16H0010600000, C07K0016220000	(71) Name of Applicant : 1)MESBRO TECHNOLOGIES PRIVATE LIMITED Address of Applicant :Flat no C/904, Geomatrix Dev, Plot no 29, Sector 25, Kamothe, Raigarh-410209, Maharashtra, India Maharashtra India
(31) Priority Document No	:NA	(72) Name of Inventor :
(32) Priority Date	:NA	1)Mr. Bhaskar Vijay Ajgaonkar
(33) Name of priority country	:NA	
(86) International Application No	:NA	
Filing Date	:NA	
(87) International Publication No	: NA	
(61) Patent of Addition to Application Number:	NA	
Filing Date	:NA	
(62) Divisional to Application Number	:NA	
Filing Date	:NA	

(57) Abstract :

The system and methods portrayed in this identify with online techniques for coordinated effort in network conditions. The strategies and frameworks are identified with an online clothing demonstrating framework that enables clients to have three-dimensional models of their physical profile made. Clients may buy different products as well as administrations and team up with different clients in the online condition.



No. of Pages : 10 No. of Claims : 3

(12) PATENT APPLICATION PUBLICATION

(21) Application No.201921050596 A

(19) INDIA

(22) Date of filing of Application :07/12/2019

(43) Publication Date : 11/06/2021

(54) Title of the invention : A SYSTEM FOR MONITORING OF HIGH-RISK PATIENTS •

(51) International classification	:G06Q0050220000, G16H0010600000, G16H0010200000, G16H0050200000, G06N0020000000	(71)Name of Applicant : 1)MESBRO TECHNOLOGIES PRIVATE LIMITED Address of Applicant :Flat no C/904, Geomatrix Dev, Plot no 29, Sector 25, Kamothe, Raigarh-410209, Maharashtra, India Maharashtra India
(31) Priority Document No	:NA	(72)Name of Inventor :
(32) Priority Date	:NA	1)Mr. Bhaskar Vijay Ajgaonkar
(33) Name of priority country	:NA	
(86) International Application No	:NA	
Filing Date	:NA	
(87) International Publication No	: NA	
(61) Patent of Addition to Application Number	:NA	
Filing Date	:NA	
(62) Divisional to Application Number	:NA	
Filing Date	:NA	

(57) Abstract :

Accordingly, a system for monitoring of high-risk patients using artificial intelligence without involvement of patients or patient relatives is disclosed. A system for monitoring of high risk patients using artificial intelligence comprising the steps of; Recording all the patient information in the internal database of the website; Generating a questionnaire by an attending physician as per his requirement about the patient followed by completing all the information of the patient in the questionnaire by the patient; Fulfilling all the information of the patient in the questionnaire; recording the doctorTMs voice through a recording system for making the doctorTMs voice audible to the patient for his/her satisfaction; Selecting and choosing questions using AI to create a selection of particular questions based on patient response; Obtaining a reading signal from the monitoring system; Analyzing unit for analysis of patient response on the physician criteria and for determining necessary action required.

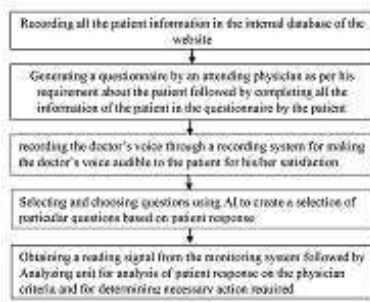

FIG 1

No. of Pages : 11 No. of Claims : 8

(54) Title of the invention : ARTIFICIAL INTELLIGENCE PROGRAM FOR GROWING TOMATOES IN GREENHOUSE

(51) International classification	:A01G0009240000, A01G0009140000, A01G0025020000, A01G0031020000, A01G0009160000	(71) Name of Applicant : 1)MESBRO TECHNOLOGIES PRIVATE LIMITED Address of Applicant :Flat no C/904, Geomatrix Dev, Plot no 29, Sector 25, Kamothe, Raigarh-410209, Maharashtra, India Maharashtra India
(31) Priority Document No	:NA	(72) Name of Inventor :
(32) Priority Date	:NA	1)Mr. Bhaskar Vijay Ajgaonkar
(33) Name of priority country	:NA	
(86) International Application No	:NA	
Filing Date	:NA	
(87) International Publication No	: NA	
(61) Patent of Addition to Application Number	:NA	
Filing Date	:NA	
(62) Divisional to Application Number	:NA	
Filing Date	:NA	

(57) Abstract :

The system for growing tomatoes in the greenhouse using artificial intelligence program is disclosed. The system includes designing of artificial intelligence program for growing tomatoes in greenhouse with proper control on temperature, humidity, supply of nutrients, supply of fertilizers, supply of pesticides. The nutrients are distributing to crop through drip irrigation system which is mounted on roof of greenhouse. And this system is controlled by computers. And this artificial intelligence program can be handled remotely as well.

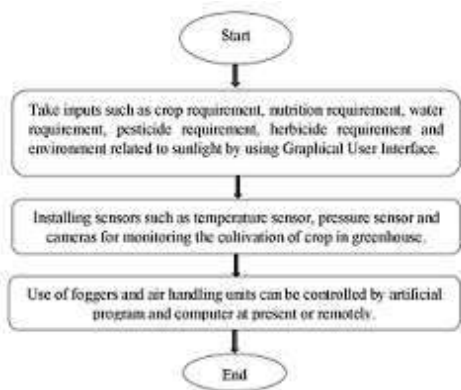

FIG 1

No. of Pages : 7 No. of Claims : 6

(12) PATENT APPLICATION PUBLICATION

(21) Application No.201921050663 A

(19) INDIA

(22) Date of filing of Application :09/12/2019

(43) Publication Date : 11/06/2021

(54) Title of the invention : MULTI-DIRECTIONAL AND MULTI-FUNCTIONAL LIGHTING ASSEMBLY

(51) International classification :H01H0025000000,
F21V0033000000,
F21V0031000000,
F21V0021260000,
F21V0023000000

(31) Priority Document No :NA
(32) Priority Date :NA
(33) Name of priority country :NA
(86) International Application No :NA
Filing Date :NA
(87) International Publication No : NA
(61) Patent of Addition to Application Number :NA
Filing Date :NA
(62) Divisional to Application Number :NA
Filing Date :NA

(71)Name of Applicant :
1)ARVIND BHALLAMUDI
Address of Applicant :PLOT NO. B-169 ANANTA, IIT
BOMBAY, POWAI, MUMBAI 400076, MAHARASHTRA,
INDIA Maharashtra India
(72)Name of Inventor :
1)ARVIND BHALLAMUDI

(57) Abstract :

ABSTRACT MULTI-DIRECTIONAL AND MULTI-FUNCTIONAL LIGHTING ASSEMBLY A multi-directional and multi-functional lighting assembly (100), said assembly being a modular lamp with a detachable torch, said assembly comprising: a base (30); a torch (10) being a multi-direction-illuminating torch; a joint (20) to couple said torch (10) to said base (30), in that, said joint (20) being a spherical joint (20), said joint (20) not being fixed to said base (30), said joint (20) configured to angularly displace as a ball and socket joint, thereby angularly displacing said torch (10) with respect to said base (30). [[FIGURE 2]]

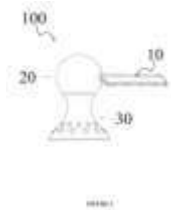

No. of Pages : 20 No. of Claims : 10

(54) Title of the invention : A METHOD OF PULSED POWER TRANSMISSION AND SYSTEM THEREOF

(51) International classification :F03G0007100000,
H02K0053000000,
F02B0075320000,
F16J0007000000,
F01B0009020000

(31) Priority Document No :NA
(32) Priority Date :NA
(33) Name of priority country :NA
(86) International Application No :NA
Filing Date :NA
(87) International Publication No : NA
(61) Patent of Addition to Application Number:NA
Filing Date :NA
(62) Divisional to Application Number :NA
Filing Date :NA

(71)**Name of Applicant :**
1)SAURABH VIKAS CHAUDHARI
Address of Applicant :SAURABH VIKAS CHAUDHARI
Indian S/O Vikas Kisan Chaudhari H. N. 1341, Near
Swaminarayan Temple, Savda, Tal. - Raver, Distt. Jalgaon,
(Maharashtra) -425502 Maharashtra India
(72)**Name of Inventor :**
1)SAURABH VIKAS CHAUDHARI

(57) Abstract :

A pulsed power transmission method and system is completely different from the conventional continuous power transmission we are using today. A pulsed power transmission system comprising of; a power input unit 501, a pulsed power transmission unit 502, a power receiving unit 503, and a starter unit 504. A power unit comprises a prime mover 100. A pulsed power transmission unit comprises an assembly of at least one rotational to reciprocating motion generating mechanism, at least one intermittent mechanism, at least one a reciprocating to rotational motion generating mechanism 201 with common input shaft 203 and output shaft 204, and a lubrication chamber 112. A power receiving unit 503 comprises a power receiving object 109. And a starter unit 504 comprises a starter mechanism 202.

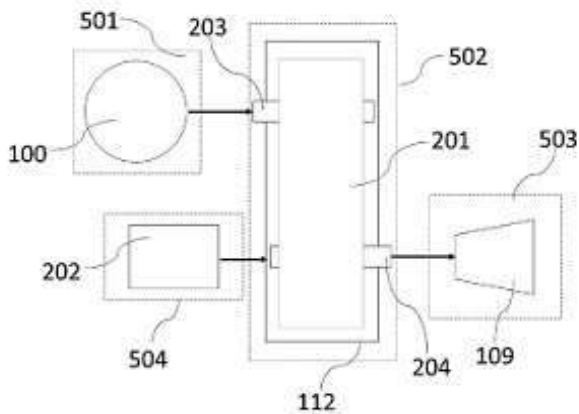

FIG. 1

No. of Pages : 22 No. of Claims : 10

(54) Title of the invention : A PROCESS FOR RECOVERY OF PROPYLENE AND LPG

(51) International classification	:C10G0011180000, C10G0007020000, C10G0070060000, B01J0029080000, C10G0055060000	(71)Name of Applicant : 1)RELIANCE INDUSTRIES LIMITED Address of Applicant :3RD FLOOR, MAKER CHAMBER- IV, 222, NARIMAN POINT, MUMBAI-400021, MAHARASHTRA, INDIA Maharashtra India
(31) Priority Document No	:NA	(72)Name of Inventor :
(32) Priority Date	:NA	1)YADAV, Manoj
(33) Name of priority country	:NA	2)LIMBASIYA, Nilamkumar Babubhai
(86) International Application No	:NA	3)MANDAL, Sukumar
Filing Date	:NA	4)DAS, Asit Kumar
(87) International Publication No	: NA	
(61) Patent of Addition to Application Number	:NA	
Filing Date	:NA	
(62) Divisional to Application Number	:NA	
Filing Date	:NA	

(57) Abstract :

The present disclosure relates to a process for enhanced recovery of propylene and LPG from a gaseous product mixture produced by contacting a heavy hydrocarbon feed with a fluid catalytic cracking (FCC) catalyst in a fluid catalytic cracker. In the process of the present disclosure, the gaseous product mixture comprising fuel gases obtained after two stage fractionation, compression and separation of the gaseous product mixture, are contacted with unstabilized naphtha, a portion of debutanized hydrocarbons and a portion of de-pentanized hydrocarbons to absorb C3 and C4 hydrocarbons present in the fuel gases, thereby leading to enhanced recovery of C3 and C4 hydrocarbons.

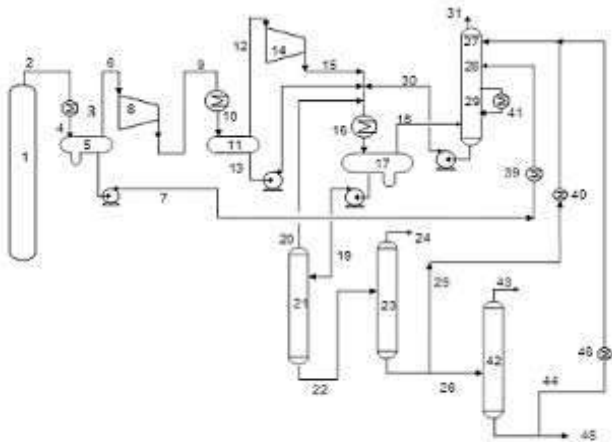

Figure 1

No. of Pages : 17 No. of Claims : 4

(54) Title of the invention : METHOD OF MANUFACTURING FABRIC FROM CELLULOSIC BASED RECYCLED FIBRE AND GARMENT THEREOF

(51) International classification :D06M0013453000,
D06B0005080000,
B32B0029020000,
B32B0007040000,
D02G0003120000

(31) Priority Document No :NA
(32) Priority Date :NA
(33) Name of priority country :NA
(86) International Application No :NA
Filing Date :NA
(87) International Publication No : NA
(61) Patent of Addition to Application Number :NA
Filing Date :NA
(62) Divisional to Application Number :NA
Filing Date :NA

(71)**Name of Applicant :**
1)Arvind Limited
Address of Applicant :Naroda Road, Ahmedabad - 380025,
Gujarat, India Gujarat India

(72)**Name of Inventor :**
1)Debasish Halder
2)Punit Lalbhai
3)Rahul DattaRoy

(57) Abstract :

The present invention relates to a method of manufacturing fabric from cellulosic based recycled fibre only.

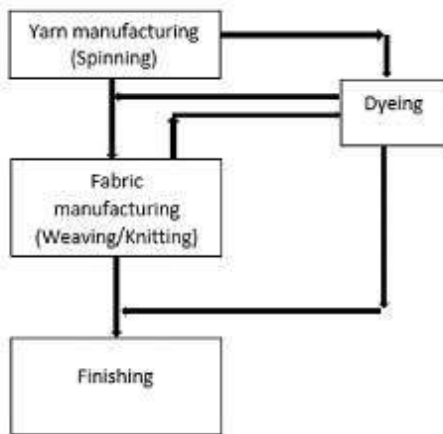

FIG. 1

No. of Pages : 10 No. of Claims : 14

(12) PATENT APPLICATION PUBLICATION

(21) Application No.201921050695 A

(19) INDIA

(22) Date of filing of Application :09/12/2019

(43) Publication Date : 11/06/2021

(54) Title of the invention : STABLE TOPICAL PHARMACEUTICAL COMPOSITIONS OF LULICONAZOLE •

(51) International classification	:A61K0009000000, A61K0031417800, A61K0047100000, C07D0409060000, A61K0009060000	(71) Name of Applicant : 1)CADILA HEALTHCARE LIMITED Address of Applicant :Zydus Corporate Park, Scheme No. 63, Survey No. 536, Khoraj (Gandhinagar), Nr. Vaishnodevi Circle, Sarkhej Gandhinagar Highway, Ahmedabad 382481, Gujarat, India Gujarat India
(31) Priority Document No	:NA	(72) Name of Inventor :
(32) Priority Date	:NA	1)MUTHAIYYAN, Kannan Essakimuthu
(33) Name of priority country	:NA	2)UKAWALA, Mukeshkumar Hirabhai
(86) International Application No	:NA	3)PATEL, Jitendrakumar Dashrathlal
Filing Date	:NA	4)PRAJAPATI, Amitkumar Rameshbhai
(87) International Publication No	: NA	
(61) Patent of Addition to Application	:NA	
Number	:NA	
Filing Date	:NA	
(62) Divisional to Application Number	:NA	
Filing Date	:NA	

(57) Abstract :

ABSTRACT STABLE TOPICAL PHARMACEUTICAL COMPOSITIONS OF LULICONAZOLE • The present invention relates to stable pharmaceutical compositions for topical administration on skin having increased permeability comprising luliconazole and combination of diethylene glycol monoethyl ether and medium chain triglycerides. The present invention also relates to processes for preparation of such pharmaceutical compositions.

No. of Pages : 18 No. of Claims : 9

(12) PATENT APPLICATION PUBLICATION

(21) Application No.201921050698 A

(19) INDIA

(22) Date of filing of Application :09/12/2019

(43) Publication Date : 11/06/2021

(54) Title of the invention : MICROSPHERES LOADED MENTHOL BASED MUCOADHESIVE GEL FOR MOUTH ULCER

(51) International classification	:A61K0009000000, A61K0009700000, A61K0047100000, A61K0009160000, A61Q0011000000	(71) Name of Applicant : 1)KAUR CHANCHAL DEEP Address of Applicant :SHRI RAWATPURA SARKAR INSTITUTE OF PHARMACY, BEHIND HOLIDAY RESORT, NEAR POWER GRID COR., KUMHARI, DIST - DURG (C.G.) - 490042, CHATTISGARH, INDIA. Chattisgarh India
(31) Priority Document No	:NA	2)JOSHI RENJIL
(32) Priority Date	:NA	3)GUPTA ANSHITA
(33) Name of priority country	:NA	(72) Name of Inventor :
(86) International Application No	:NA	1)KAUR CHANCHAL DEEP
Filing Date	:NA	2)JOSHI RENJIL
(87) International Publication No	: NA	3)GUPTA ANSHITA
(61) Patent of Addition to Application	:NA	
Number	:NA	
Filing Date	:NA	
(62) Divisional to Application Number	:NA	
Filing Date	:NA	

(57) Abstract :

The present invention relates to a mucoadhesive gel composition for mouth ulcers comprising a microbead loaded with L-ascorbic acid and/or a pharmaceutically acceptable salt thereof; a gelling agent; a cooling agent; a humectant; and a preservative.

No. of Pages : 29 No. of Claims : 10

(12) PATENT APPLICATION PUBLICATION

(21) Application No.201921050710 A

(19) INDIA

(22) Date of filing of Application :09/12/2019

(43) Publication Date : 11/06/2021

(54) Title of the invention : NOVEL PHYTOACTIVE EXTRACTS BASED FORMULATIONS OF HELICTERES ISORA FOR MUSCULAR AND NERVINE DISORDERS

(51) International classification	:A23L0033105000, A61K0008970000, H04B0007060000, A01N0057200000, A61K0036185000	(71) Name of Applicant : 1)SONI DEEPENDRA Address of Applicant :SHRI RAWATPURA SARKAR SCHOOL OF PHARMACY, SHRI RAWATPURA SARKAR UNIVERSITY, DHANELI, RAIPUR, CHHATTISGARH - 490042, INDIA. Chattisgarh India
(31) Priority Document No	:NA	2)KAUR CHANCHAL DEEP
(32) Priority Date	:NA	3)GUPTA ANSHITA
(33) Name of priority country	:NA	(72) Name of Inventor :
(86) International Application No	:NA	1)SONI DEEPENDRA
Filing Date	:NA	2)KAUR CHANCHAL DEEP
(87) International Publication No	: NA	3)GUPTA ANSHITA
(61) Patent of Addition to Application Number	:NA	
Filing Date	:NA	
(62) Divisional to Application Number	:NA	
Filing Date	:NA	

(57) Abstract :

The present invention relates to preparation of plant extracts (Alcoholic, hydroalcoholic, organic, aqueous) based formulations (gels, creams, lotions, ointments, tablet, capsules, sprays, oils) of Helicteres isora plant for the treatment of muscular and nervine disorders which includes muscular stiffness, joint pain, nerve inflammation, nerve pain, inflammation and other related disorders thereof.

No. of Pages : 23 No. of Claims : 7

(12) PATENT APPLICATION PUBLICATION

(21) Application No.201921050736 A

(19) INDIA

(22) Date of filing of Application :09/12/2019

(43) Publication Date : 11/06/2021

(54) Title of the invention : N-(BENZO[D]THIAZOL-2-YL)-2-(2-(2-OXO-2H-CHROMEN-3-YL)-1H-BENZO[D]IMIDAZOL-1-YL)ACETAMIDE DERIVATIVES AND USE THEREOF.

(51) International classification	:H01M0010440000, G11B0017049000, G03G0015080000, A24D0003060000, B65D0006220000	(71)Name of Applicant : 1)KALPESH B. THAKER Address of Applicant :House No. Microcare Laboratory & Tuberculosis Research Centre, City Surat State Gujarat Country India Pin code 395003 Gujarat India
(31) Priority Document No	:NA	2)DR. HITESH D. PATEL
(32) Priority Date	:NA	3)SMITA D. RAJANI
(33) Name of priority country	:NA	4)DHANJI P. RAJANI
(86) International Application No	:NA	5)MAHESH S. VASAVA
Filing Date	:NA	(72)Name of Inventor :
(87) International Publication No	: NA	1)SMITA D. RAJANI
(61) Patent of Addition to Application	:NA	2)MAHESH S. VASAVA
Number	:NA	3)DHANJI P. RAJANI
Filing Date	:NA	4)DR. HITESH D. PATEL
(62) Divisional to Application Number	:NA	5)KALPESH B. THAKER
Filing Date	:NA	

(57) Abstract :

TITLE : N-(BENZO[D]THIAZOL-2-YL)-2-(2-(2-OXO-2H-CHROMEN-3-YL)-1H-BENZO[D]IMIDAZOL-1-YL)ACETAMIDE DERIVATIVES AND USE THEREOF. ABSTRACT A compound of A N-(benzo[d]thiazol-2-yl)-2-(2-(2-oxo-2H-chromen-3-yl)-1H-benzo[d]imidazol-1-yl) acetamide derivative compounds of formula (I), pharmaceutical composition. In particular the present invention provides a novel N-(benzo[d] thiazol-2-yl) -2-(2-(2-oxo-2H-chromen-3-yl))-1H- benzo[d] imidazol-1-yl) acetamide derivative compounds as anti-bacterial, antituberculosis, MDR-TB, anti-malarial, or anti- oxidant agent. Further the present invention relates to a pharmaceutical compositions containing the compounds N-(benzo[d]thiazol-2-yl)-2-(2-(2-oxo-2H-chromen-3-yl)-1H-benzo[d]imidazol-1-yl) acetamide derivative compounds of formula (I) for treatment of fungal infections.

No. of Pages : 36 No. of Claims : 10

(12) PATENT APPLICATION PUBLICATION

(21) Application No.201921050782 A

(19) INDIA

(22) Date of filing of Application :09/12/2019

(43) Publication Date : 11/06/2021

(54) Title of the invention : AN IMPROVED SHAPED CATALYST COMPOSITE AND A PROCESS FOR UPGRADING HYDROCARBON STREAM

(51) International classification	:B01J0037000000, B01J0037030000, H04N0021810000, B01J0029700000, B01J0029400000	(71) Name of Applicant : 1)RELIANCE INDUSTRIES LIMITED Address of Applicant :3rd Floor, Maker Chamber-IV, 222, Nariman Point, Mumbai 400 021, Maharashtra, India Maharashtra India
(31) Priority Document No	:NA	(72) Name of Inventor :
(32) Priority Date	:NA	1)KRISHNA REDDY JAKKIDI
(33) Name of priority country	:NA	2)MANTRI KSHUDIRAM
(86) International Application No	:NA	3)GANESAN RAMAN
Filing Date	:NA	4)JAGANNATH DAS
(87) International Publication No	: NA	5)RAKSHVIR JASRA
(61) Patent of Addition to Application Number	:NA	
Filing Date	:NA	
(62) Divisional to Application Number	:NA	
Filing Date	:NA	

(57) Abstract :

[0063]. The instant disclosure is in the field of chemical sciences, more particularly to synthetic chemistry and material science. The present disclosure generally relates to an improved shaped catalyst composite; and a method for upgrading hydrocarbon stream through removal of olefin impurities present therein and producing a hydrocarbon stream substantially free form olefinic contaminants using the said catalyst composite. In particular, the present invention relates an improved shaped catalyst composite comprising of a treated zeolite selected from MFI and MWW family of zeolites, and a compositing material selected from group of compounds consisting of oxides of elements from group III A and group IV A, or a combination thereof. More particularly, the present invention relates to a mesoporous MCM-22 composite catalyst useful for reducing olefin content from a commercial C8+ aromatic stream.

No. of Pages : 19 No. of Claims : 20

(54) Title of the invention : METHODS AND SYSTEMS FOR DETERMINING MISSING DATA IN IMBALANCED DATASETS USING AUTOMATED PREDICTING FUNCTIONS

(51) International classification	:H01M0010440000, G11B0017049000, G03G0015080000, A24D0003060000, B65D0006220000	(71)Name of Applicant : 1)Tata Consultancy Services Limited Address of Applicant :Nirmal Building, 9th Floor, Nariman Point, Mumbai - 400021, Maharashtra, India Maharashtra India
(31) Priority Document No	:NA	(72)Name of Inventor : 1)KUNDE, Shruti
(32) Priority Date	:NA	2)MISHRA, Mayank
(33) Name of priority country	:NA	3)NAMBIAR, Manoj
(86) International Application No	:NA	4)PANDIT, Amey
Filing Date	:NA	5)SHROFF, Gautam
(87) International Publication No	: NA	6)GUPTA, Shashank
(61) Patent of Addition to Application Number	:NA	
Filing Date	:NA	
(62) Divisional to Application Number	:NA	
Filing Date	:NA	

(57) Abstract :

This disclosure relates to determining missing data in imbalanced datasets using automated predicting functions. State-of-the-art methods are time bound which means they are dependent on time series data, involve high computation cost, do not factor in correlations between features and may also end up introducing bias in data. The present disclosure provides a high performance, faster and efficient method for determining missing data in a plurality of imbalanced datasets by first determining dependencies across a plurality of features in the plurality of imbalanced datasets and then automatically generating a set of predictive functions using machine learning models. The set of automated predicted functions provide good coverage to the plurality of imbalanced datasets and are applied to a plurality of generative models. Output of the method of present disclosure is a set of probabilistic labels that are assigned to one or more missing values in the plurality of imbalanced datasets.



No. of Pages : 40 No. of Claims : 12

(12) PATENT APPLICATION PUBLICATION

(21) Application No.201921050885 A

(19) INDIA

(22) Date of filing of Application :10/12/2019

(43) Publication Date : 11/06/2021

(54) Title of the invention : AN APPARATUS AND A METHOD FOR INDUCTION HARDENING OF CRANKSHAFTS

(51) International classification	:A23K0020147000, C12P0019040000, B82Y0030000000, C22B0003000000, C08L0097020000	(71)Name of Applicant : 1)Bharat Forge Limited Address of Applicant :Mundhwa, Pune - 411036, Maharashtra, India Maharashtra India
(31) Priority Document No	:NA	(72)Name of Inventor :
(32) Priority Date	:NA	1)Dr. Babasaheb Neelkanth KALYANI
(33) Name of priority country	:NA	2)Mr. Sushant Baburao PUSTAKE
(86) International Application No	:NA	3)Mr. Dhananjay Dinkarrao GOTMARE,
Filing Date	:NA	4)Mr. Sachin Kashiram TANKASALI
(87) International Publication No	: NA	5)Mr. Vidyanad Gopal POWAR
(61) Patent of Addition to Application Number	:NA	6)Mr. Babu Arun ISHWARE
Filing Date	:NA	
(62) Divisional to Application Number	:NA	
Filing Date	:NA	

(57) Abstract :

The invention discloses a method and apparatus for induction hardening to avoid defects during induction hardening of a crankshaft, especially by avoiding overheating of the region adjoining to the area being induction hardened and without any expensive or complex changes to the induction hardening equipment or its software programming. The apparatus of the invention is a heat sink adapter (A) made in two parts - the journal-side half (6) is the heat extractor, and the pin-side half (8) simply to facilitate mounting of the heat sink adapter (A) on the web (5). Without this apparatus, the heat will entirely be transferred to the adjoining regions only. The method of the invention discloses the step of providing a heat sink adapter by ensuring there is no gap, preferably between journal-side half (6) of said heat sink adapter (A) and the external shape or surface of web (5). Representative Figure: Figure 3

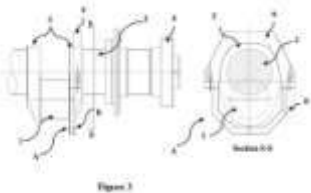

No. of Pages : 24 No. of Claims : 11

(54) Title of the invention : A DIGITAL SYSTEM FOR THE MANAGEMENT OF RESPIRATORY DISEASES.

(51) International classification :A61M0015000000,
G01N0033680000,
A61B0005020500,
A61B0005000000,
A61M0016120000

(31) Priority Document No :NA
(32) Priority Date :NA
(33) Name of priority country :NA
(86) International Application No :NA
Filing Date :NA
(87) International Publication No : NA
(61) Patent of Addition to Application Number :NA
Filing Date :NA
(62) Divisional to Application Number :NA
Filing Date :NA

(71)**Name of Applicant :**
1)GAJANAN DEVIDAS SAKHARE
Address of Applicant :1101, Marigold, Suyog Nisarga,
Lohegaon Road, Wagholi, Pune- 412207 Maharashtra India

(72)**Name of Inventor :**
1)GAJANAN DEVIDAS SAKHARE
2)SHARDUL UMESH JOSHI

(57) Abstract :

The present invention discloses a device for detection and management of a respiratory disease in a patient. It further relates to the detection and providing means of management of said respiratory disease by said patient or a medical practitioner or a caregiver remotely. It also relates to the detection of respiratory capacity of said patient and use of a dose counter that helps in the effective management of said respiratory disease in said patient.

FIGURE 1: Scheme of the Invention

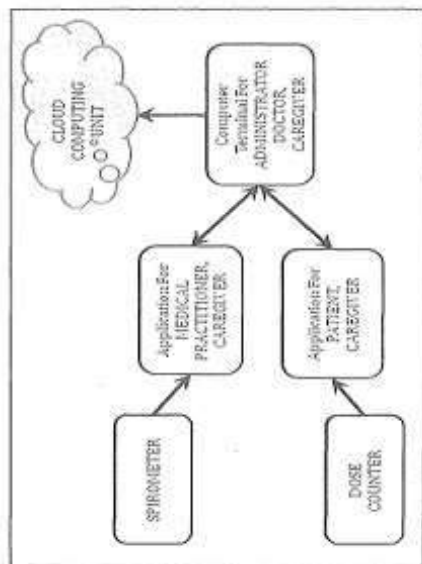

No. of Pages : 23 No. of Claims : 11

(54) Title of the invention : METHODS AND SYSTEMS FOR USING MULTI-CONNECTIVITY FOR MULTICAST TRANSMISSIONS IN A COMMUNICATION SYSTEM

(51) International classification :H04W0004060000,
H04W0076150000,
H04W0072000000,
H04L0012180000,
H04L0005000000

(31) Priority Document No :NA
(32) Priority Date :NA
(33) Name of priority country :NA
(86) International Application No :NA
Filing Date :NA
(87) International Publication No : NA
(61) Patent of Addition to Application Number :NA
Filing Date :NA
(62) Divisional to Application Number :NA
Filing Date :NA

(71)**Name of Applicant :**
1)Indian Institute of Technology Bombay
Address of Applicant :IIT Bombay, Powai, Mumbai
Maharashtra 400076, India Maharashtra India

(72)**Name of Inventor :**
1)Abhay Karandikar
2)Pranav Kumar Jha
3)Prasanna Chaporkar
4)Sadaf Ul Zuhra

(57) Abstract :

Methods and systems for using multi-connectivity for multicast transmissions in a communication system. A method disclosed herein includes using multi-connectivity that enables at least one User Equipment (UE) to receive at least one Multimedia Broadcast Multicast Service (MBMS) content from the plurality of BSs at a time on different physical resource blocks. The method further includes enabling the plurality of BSs to maintain independent MBMS sessions for transmitting the at least one MBMS content to the at least one UE without synchronization. The method further includes enabling the at least one UE to combine the at least one MBMS content received from the plurality of BSs or to select a MBMS content from the received at least one MBMS content. FIG. 5

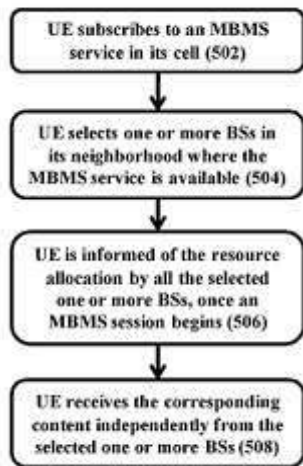

FIG. 5

No. of Pages : 52 No. of Claims : 32

(54) Title of the invention : TERMINAL CONTROL METHOD AND APPARATUS, TERMINAL AND STORAGE MEDIUM

(51) International classification	:H04N0005235000, H04N0005232000, H04L0027000000, G06F0003048800, G05B0015020000	(71) Name of Applicant : 1)BEIJING XIAOMI MOBILE SOFTWARE CO., LTD. Address of Applicant :No. 018, Floor 8, Building 6, Yard 33, Middle Xierqi Road, Haidian District, Beijing 100085, China China
(31) Priority Document No	:201911234423.9	(72) Name of Inventor :
(32) Priority Date	:05/12/2019	1)BAI, Dongshu
(33) Name of priority country	:China	2)ZHUANG, Jiajia
(86) International Application No	:NA	3)LIU, Rong
Filing Date	:NA	4)ZHENG, Qing
(87) International Publication No	: NA	
(61) Patent of Addition to Application Number	:NA	
Filing Date	:NA	
(62) Divisional to Application Number	:NA	
Filing Date	:NA	

(57) Abstract :

The present disclosure discloses a terminal control method and apparatus, a terminal and a storage medium, which belong to the field of computer technologies. The method includes: receiving (101, 501, 901) a focus mode starting instruction; entering (102) a focus mode according to the focus mode starting instruction; performing (103, 907), in response to an application-invoking request received within a duration of the focus mode, process control on an application being invoked; and exiting (104, 908) the focus mode when the duration of the focus mode ends.

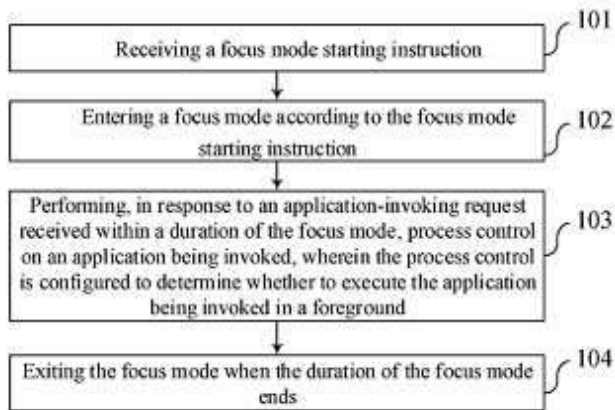

FIG. 1

No. of Pages : 41 No. of Claims : 15

(54) Title of the invention : IMAGING LENS ASSEMBLY AND ELECTRONIC DEVICE

(51) International classification :G02B0013000000,
G02B0007020000,
H04N0005225000,
G02B0001040000,
G02B0005000000

(31) Priority Document No :108144800

(32) Priority Date :06/12/2019

(33) Name of priority country /region :Taiwan

(86) International Application No :NA
Filing Date :NA

(87) International Publication No : NA

(61) Patent of Addition to Application Number :NA
Filing Date :NA

(62) Divisional to Application Number :NA
Filing Date :NA

(71)Name of Applicant :
1)LARGAN PRECISION CO., LTD.
Address of Applicant :No.11, Jingke Rd., Nantun Dist.,
Taichung City 408, Taiwan

(72)Name of Inventor :
1)Jyun-Jia CHENG
2)Lin-An CHANG
3)Ming-Ta CHOU
4)Cheng-Feng LIN

(57) Abstract :

An imaging lens assembly has an optical axis, and includes a plastic carrier element and an imaging lens element set. The plastic carrier element includes an object-side surface, an image-side surface, an outer surface and an inner surface. The object-side surface includes an object-side opening. The image-side surface includes an image-side opening. The inner surface is connected to the object-side opening and the image-side opening. The imaging lens element set is disposed in the plastic carrier element, and includes at least three lens elements, each of at least two adjacent lens elements of the lens elements includes a first axial assembling structure, the first axial assembling structures are corresponding to and connected to each other. A solid medium interval is maintained between the adjacent lens elements and the inner surface. The solid medium interval is directly contacted with the adjacent lens elements and the inner surface.

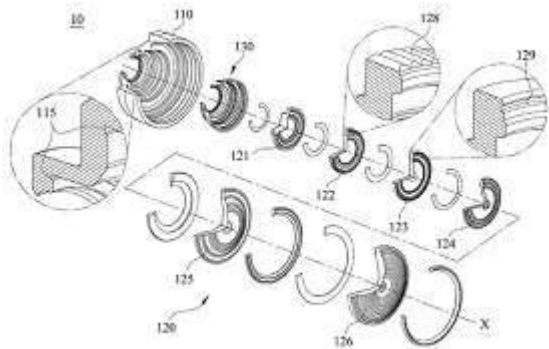

Fig. 1A

No. of Pages : 115 No. of Claims : 22

(54) Title of the invention : RENEWAL OF ONE-TIME KEYS

(51) International classification :H04L0029060000,
H04L0009080000,
H04L0012280000,
H04W0012040000,
H04L0029080000

(31) Priority Document No :1913754
(32) Priority Date :04/12/2019
(33) Name of priority country :France
(86) International Application No :NA
Filing Date :NA
(87) International Publication No : NA
(61) Patent of Addition to Application Number :NA
Filing Date :NA
(62) Divisional to Application Number :NA
Filing Date :NA

(71)**Name of Applicant :**
1)SANGLE-FERRIERE, Bruno
Address of Applicant :47 Boulevard Beausjour, 75016 PARIS, France. France
(72)**Name of Inventor :**
1)SANGLE-FERRIERE, Bruno

(57) Abstract :

Method for securing communication within a system comprising at least one server and at least two appliances able to communicate with the server and with each other, wherein a pair of appliances communicating together and having at least one shared one-time encryption key for securing communication between the two has at least one other shared one-time encryption key supplied by the server following the connection of only one of the two appliances to said server. Figure 1 is the representative figure.

(Fig 1)

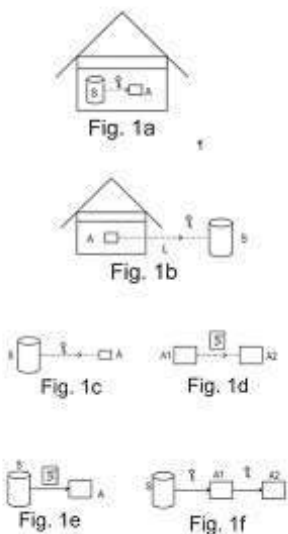

No. of Pages : 76 No. of Claims : 20

(54) Title of the invention : INTEGRATED TRANSMISSION WITH CVP AND POWER ELECTRONICS APPARATUS

(51) International classification	:F16H0057040000, F16H0037080000, F16H0057020000, F16H0003000000, H02J0007020000	(71) Name of Applicant : 1)DEERE & COMPANY Address of Applicant :One John Deere Place, Moline, Illinois, 61265, USA. U.S.A.
(31) Priority Document No	:16/707453	(72) Name of Inventor :
(32) Priority Date	:09/12/2019	1)Stacy K. Worley
(33) Name of priority country	:U.S.A.	2)Ronald D. Bremner
(86) International Application No	:NA	
Filing Date	:NA	
(87) International Publication No	: NA	
(61) Patent of Addition to Application Number:	:NA	
Filing Date	:NA	
(62) Divisional to Application Number	:NA	
Filing Date	:NA	

(57) Abstract :

An integrated transmission includes a transmission housing having a first housing face through which the input shaft extends; a CVP housed within the housing; and a transmission assembly. The transmission assembly includes an input arrangement contained within the housing and having at least one input transmission component selectively coupling the engine power and the CVP power; a variator arrangement contained within the housing, configured to receive the engine and CVP power and to selectively transfer the engine power, CVP power, and a summing of engine and CVP power as variator output power; and a transmission gear arrangement contained within the transmission housing engaged with the variator arrangement and configured to provide a selective gear reduction for transmission to an output shaft that extends out of the transmission housing. The integrated transmission includes a power electronics apparatus arranged within or on the transmission housing and electrically coupled to the CVP. FIG 2

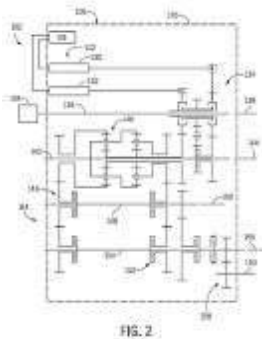

No. of Pages : 48 No. of Claims : 20

(54) Title of the invention : FLUSH MECHANISM FOR A TOILET TANK WITH AXIAL AND VERTICAL BLOCKING

(51) International classification :A61B0017000000,
A47K0013100000,
E03D0001140000,
E01D0019100000,
H01L0033200000

(31) Priority Document No :19383088.2

(32) Priority Date :05/12/2019

(33) Name of priority country :EPO

(86) International Application No :NA
Filing Date :NA

(87) International Publication No : NA

(61) Patent of Addition to Application Number :NA
Filing Date :NA

(62) Divisional to Application Number :NA
Filing Date :NA

(71)Name of Applicant :
1)FOMINAYA, S.A.
Address of Applicant :Carretera del Pla, s/n, 46117 Btera
(Valencia), Spain Spain

(72)Name of Inventor :
1)FOMINAYA GONZ • LEZ, Pablo

(57) Abstract :

A flush mechanism for a toilet tank with axial and vertical blocking which comprises an elongated part fitted inside a centred hole that passes through a top base (4a) of an actuating bridge (4) of the discharger (5), in which the position of said elongated part can be adjusted in its axial direction, and where the elongated part (1) is associated with a push mechanism, which once activated moves the actuating bridge (4) of the discharger (5) downwards through the elongated part (1), and it comprises first means for axial blocking (3, 8), and it is characterised in that it also comprises blocking means (10, 20) for the actuating bridge (4), in such a manner that the negative movement of the actuating bridge (4) in the Z axis is blocked.

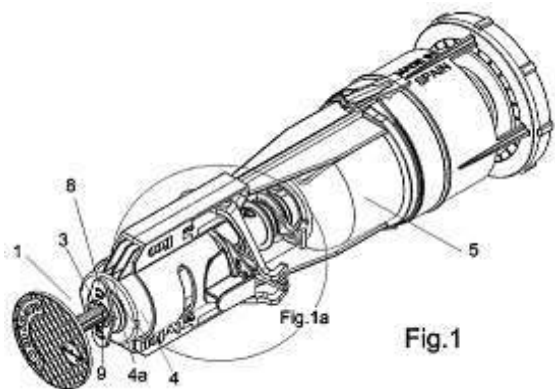

No. of Pages : 16 No. of Claims : 8

(12) PATENT APPLICATION PUBLICATION

(21) Application No.202127004436 A

(19) INDIA

(22) Date of filing of Application :02/02/2021

(43) Publication Date : 11/06/2021

(54) Title of the invention : P2X3 RECEPTOR ANTAGONISTS

(51) International classification	:A61P0025040000, C07D0403120000, A61K0031402500, C07D0413100000, C07C0233310000	(71)Name of Applicant : 1)RECORDATI INDUSTRIA CHIMICA E FARMACEUTICA SPA Address of Applicant :Via Matteo Civitali 1 20148 Milano Italy
(31) Priority Document No	:1811452.0	(72)Name of Inventor :
(32) Priority Date	:12/07/2018	1)GRAZIANI, Davide
(33) Name of priority country	:U.K.	2)MENEGON, Sergio
(86) International Application No	:PCT/EP2019/068681	3)ANGELICO, Patrizia
Filing Date	:11/07/2019	4)RIVA, Carlo
(87) International Publication No	:WO 2020/011921	
(61) Patent of Addition to Application Number	:NA	
Filing Date	:NA	
(62) Divisional to Application Number	:NA	
Filing Date	:NA	

(57) Abstract :

This invention relates to compounds of formula (I); and their use as antagonists of P2X3 and P2X2/3 receptor activity, pharmaceutical compositions comprising such compounds, and methods of treatment therewith. Compounds of the invention can be used for the treatment and/or prevention of pain and chronic pain and tolerance to analgesic, respiratory disorders and dysfunctions, and treatment of overactive bladder, bladder pain syndrome, dysuria and in general in genitourinary diseases, cardiovascular disorders and more in general for the potential treatment of visceral organ diseases and disorders characterized by the involvement of P2X3 and P2X2/3 receptors.

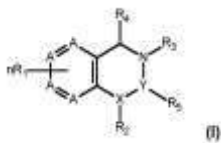

No. of Pages : 188 No. of Claims : 15

(12) PATENT APPLICATION PUBLICATION

(21) Application No.202127004438 A

(19) INDIA

(22) Date of filing of Application :02/02/2021

(43) Publication Date : 11/06/2021

(54) Title of the invention : METHOD FOR INHIBITING UNWANTED RADICAL POLYMERISATION OF ACRYLIC ACID PRESENT IN A LIQUID PHASE P

(51) International classification :C07C0051500000,
C07C0057040000,
C07C0051440000,
C08F0020060000,
H01B0003440000

(31) Priority Document No :18185760.8

(32) Priority Date :26/07/2018

(33) Name of priority country :EPO

(86) International Application No :PCT/EP2019/069079
Filing Date :16/07/2019

(87) International Publication No :WO 2020/020697

(61) Patent of Addition to Application Number :NA
Filing Date :NA

(62) Divisional to Application Number :NA
Filing Date :NA

(71)Name of Applicant :

1)BASF SE

Address of Applicant :Carl-Bosch-Strasse 38 67056
Ludwigshafen am Rhein Germany

(72)Name of Inventor :

1)JANSSEN, Nicole

2)ZUROWSKI, Peter

3)HAMMON, Ulrich

4)HAREMZA, Sylke

(57) Abstract :

The invention relates to a method for inhibiting unwanted radical polymerisation of acrylic acid present in a liquid phase P, wherein: the acrylic acid content of P is at least 10% by weight; the liquid phase P contains 25 to 1,000 ppm by weight glyoxal in relation to the weight of the acrylic acid in P; and furfural is added to the liquid phase P, in an amount that results in a furfural content of 25 to 1,000 ppm by weight in relation to the weight of the acrylic acid in P. The invention further relates to a liquid phase P, wherein: the acrylic acid content of P is at least 10% by weight; and the liquid phase P contains 25 to 1,000 ppm by weight glyoxal and 25 to 1,000 ppm by weight furfural, each in relation to the weight of the acrylic acid in P.

No. of Pages : 23 No. of Claims : 24

(12) PATENT APPLICATION PUBLICATION

(21) Application No.202127004439 A

(19) INDIA

(22) Date of filing of Application :02/02/2021

(43) Publication Date : 11/06/2021

(54) Title of the invention : PROCESS FOR PREPARING A ZEOLITIC MATERIAL HAVING A FRAMEWORK TYPE FER

(51) International classification :C01B0039440000,
B01J0029650000,
B01J0029700000,
C01B0039480000,
C01B0039020000

(31) Priority Document No :18185968.7

(32) Priority Date :27/07/2018

(33) Name of priority country :EPO

(86) International Application No :PCT/EP2019/070157
Filing Date :26/07/2019

(87) International Publication No :WO 2020/021054

(61) Patent of Addition to Application Number :NA
Filing Date :NA

(62) Divisional to Application Number :NA
Filing Date :NA

(71)Name of Applicant :

1)BASF SE

Address of Applicant :Carl-Bosch-Strasse 38 67056
Ludwigshafen am Rhein Germany

(72)Name of Inventor :

1)PARVULESCU, Andrei-Nicolae

2)MCGUIRE, Robert

3)MUELLER, Ulrich

4)KROMER, Alexander

(57) Abstract :

The present invention relates to a process for preparing a zeolitic material having a framework type FER and having a framework structure comprising silicon, aluminum, and oxygen, said process comprising (i) preparing an aqueous synthesis mixture comprising water; a zeolitic material having a framework type other than FER and having a framework structure comprising silicon, aluminum, and oxygen; a source of silicon other than the zeolitic material having a framework type other than FER; an organic structure directing agent comprising piperidine; a source of an alkali metal; and a source of a base; (ii) subjecting the aqueous synthesis mixture prepared according to (i) to hydrothermal synthesis conditions comprising heating the synthesis mixture to a temperature in the range of from 140 to 190 °C and keeping the synthesis mixture at a temperature in this range under autogenous pressure, obtaining a mother liquor comprising a solid material which comprises the zeolitic material having a framework type FER.

No. of Pages : 49 No. of Claims : 19

(12) PATENT APPLICATION PUBLICATION

(21) Application No.202127004465 A

(19) INDIA

(22) Date of filing of Application :02/02/2021

(43) Publication Date : 11/06/2021

(54) Title of the invention : FEED SUPPLEMENT FOR ANIMALS AND MAN

(51) International classification	:A23K0050100000, A23K0020100000, A23K0020280000, A23K0010300000, A23K0050300000	(71) Name of Applicant : 1)KOCH, Carl Frederik Maurits Address of Applicant :Keulenstraat 19a 7418 ET Deventer Netherlands
(31) Priority Document No	:2021290	(72) Name of Inventor :
(32) Priority Date	:12/07/2018	1)KOCH, Carl Frederik Maurits
(33) Name of priority country	:Netherlands	
(86) International Application No	:PCT/NL2019/050292	
Filing Date	:20/05/2019	
(87) International Publication No	:WO 2020/013685	
(61) Patent of Addition to Application Number	:NA	
Filing Date	:NA	
(62) Divisional to Application Number	:NA	
Filing Date	:NA	

(57) Abstract :

The invention is in the field of a feed or food supplement for animals or humans, a feed supplement for use as a medicament, for improving digestion of dairy animals, such as cows, for improving milk production, for improving health, especially in the gastrointestinal tract, for reducing illness, for improving skin quality, a feed comprising the feed supplement, and a method of forming said feed supplement.

No. of Pages : 11 No. of Claims : 18

(12) PATENT APPLICATION PUBLICATION

(21) Application No.202127004466 A

(19) INDIA

(22) Date of filing of Application :02/02/2021

(43) Publication Date : 11/06/2021

(54) Title of the invention : ENHANCED EXTENDED DEPTH OF FOCUSING ON BIOLOGICAL SAMPLES

(51) International classification :G06T0005500000,
H04N0005232000,
G02B0021340000,
G06T0007110000,
G06T0007130000

(31) Priority Document No :62/713076

(32) Priority Date :01/08/2018

(33) Name of priority country :U.S.A.

(86) International Application No :PCT/US2019/044639
Filing Date :01/08/2019

(87) International Publication No :WO 2020/028648

(61) Patent of Addition to Application Number :NA
Filing Date :NA

(62) Divisional to Application Number :NA
Filing Date :NA

(71)Name of Applicant :
1)CDX MEDICAL IP, INC.
Address of Applicant :2 Executive Blvd. Suffern, NY 10901
U.S.A.

(72)Name of Inventor :
1)RUTENBERG, Mark
2)SCOTT, Richard
3)TJON, Robert
4)SELTZER, Paul

(57) Abstract :

A system and method for constructing a digital composite image of a three- dimensional biological sample. The system includes an optical system that captures images of cells and tissue presented on a specimen slide. The system systematically acquires a stack of images at different segments across the specimen slide. For each segment, the system dynamically calculates an optimal focal plane. Once an optimal focal plane is determined for each of the stacks of images, the system generates a composite image by copying the sharpest objects from each of the optimal focal planes.

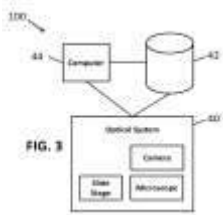

No. of Pages : 21 No. of Claims : 14

(54) Title of the invention : SESSION ESTABLISHMENT METHOD AND APPARATUS

<p>(51) International classification</p> <p>(31) Priority Document No</p> <p>(32) Priority Date</p> <p>(33) Name of priority country</p> <p>(86) International Application No</p> <p style="padding-left: 20px;">Filing Date</p> <p>(87) International Publication No</p> <p>(61) Patent of Addition to Application Number</p> <p style="padding-left: 20px;">Filing Date</p> <p>(62) Divisional to Application Number</p> <p style="padding-left: 20px;">Filing Date</p>	<p>:H04L0029080000, H04L0029060000, H04W0076150000, H04L0012460000, H04L0012751000</p> <p>:NA</p> <p>:NA</p> <p>:NA</p> <p>:PCT/CN2019/100280</p> <p>:12/08/2019</p> <p>:WO 2021/026746</p> <p>:NA</p> <p>:NA</p> <p>:NA</p> <p>:NA</p>	<p>(71)Name of Applicant :</p> <p>1)GUANGDONG OPPO MOBILE TELECOMMUNICATIONS CORP., LTD.</p> <p style="padding-left: 20px;">Address of Applicant :No. 18, Haibin Road, Wusha, Chang'an Dongguan, Guangdong 523860 China</p> <p>(72)Name of Inventor :</p> <p>1)YANG, Haorui</p> <p>2)LIU, Jianhua</p>
---	---	--

(57) Abstract :

The present application provides a session establishment method, applied to a terminal device, and comprising: sending a session establishment request to a network device, the session establishment request requesting to establish a first session, the session establishment request comprising first indication information, and the first indication information indicating that the first session is a deactivated session or an activated session; and receiving a response message for the session establishment request from the network device. If the number of DRBs reaches a number threshold, the terminal device can request, by means of the first indication information, the network device to establish a deactivated first session, and when the number of DRBs is less than the number threshold, the terminal device or the network device can activate the first session. Compared with a solution of newly establishing a first session after the number of DRBs is less than a number threshold, the solution of first establishing a deactivated session and then activating the session can establish an activated session quickly and reduce data transmission delay.



No. of Pages : 29 No. of Claims : 76

(12) PATENT APPLICATION PUBLICATION

(21) Application No.202127004488 A

(19) INDIA

(22) Date of filing of Application :02/02/2021

(43) Publication Date : 11/06/2021

(54) Title of the invention : COMPOSITION AND USES THEREOF IN AGRICULTURE

(51) International classification	:A01N0065030000, C12N0015820000, A01N0065200000, A01N0065400000, A01N0065000000	(71) Name of Applicant : 1)VALAGRO S.P.A. Address of Applicant :Via Cagliari 1 - Zona Industriale 66041 Atessa (Chieti) Italy
(31) Priority Document No	:102018000007292	(72) Name of Inventor :
(32) Priority Date	:18/07/2018	1)BIASONE, Alessandro
(33) Name of priority country	:Italy	2)DI TOMMASO, Donata
(86) International Application No	:PCT/IB2019/056153	3)POVERO, Giovanni
Filing Date	:18/07/2019	4)LORITO, Vincenzo
(87) International Publication No	:WO 2020/016825	5)PIAGGESI, Alberto
(61) Patent of Addition to Application Number	:NA	
Filing Date	:NA	
(62) Divisional to Application Number	:NA	
Filing Date	:NA	

(57) Abstract :

The present invention refers to a composition based on algal and/or plant extracts and its use in agriculture to improve water use efficiency and/or water productivity in plants and/or agricultural water management thus resulting in increased yield of crop plants per unit water used.



No. of Pages : 35 No. of Claims : 15

(12) PATENT APPLICATION PUBLICATION

(21) Application No.202127004489 A

(19) INDIA

(22) Date of filing of Application :02/02/2021

(43) Publication Date : 11/06/2021

(54) Title of the invention : INTERNAL VALVE TRANSMITTER FLANGE

(51) International classification	:A61J0001200000, A62B0009020000, A61F0002240000, F16K0037000000, F16K0031040000	(71) Name of Applicant : 1)ROSEMOUNT INC. Address of Applicant :6021 Innovation Boulevard Shakopee, Minnesota 55379 U.S.A.
(31) Priority Document No	:16/145291	(72) Name of Inventor :
(32) Priority Date	:28/09/2018	1)ETHERIDGE, Matthew Lee
(33) Name of priority country	:U.S.A.	2)STROTH, Trevor Thomas
(86) International Application No	:PCT/US2019/037938	
Filing Date	:19/06/2019	
(87) International Publication No	:WO 2020/068197	
(61) Patent of Addition to Application Number	:NA	
Filing Date	:NA	
(62) Divisional to Application Number	:NA	
Filing Date	:NA	

(57) Abstract :

A transmitter flange (104) includes a flange body having a valve opening (508) therein, the valve opening (508) having a valve seat (510), and an internal valve (504) configured to be retained in the valve opening (508). A retaining ring (506) may be configured to thread into the valve opening (508) to further retain the internal valve (504) within the opening.

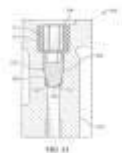

No. of Pages : 8 No. of Claims : 20

(12) PATENT APPLICATION PUBLICATION

(21) Application No.202127004490 A

(19) INDIA

(22) Date of filing of Application :02/02/2021

(43) Publication Date : 11/06/2021

(54) Title of the invention : METHOD AND APPARATUS FOR DETERMINING A MASS OF A DROPLET FROM SAMPLE DATA COLLECTED FROM A LIQUID DROPLET DISPENSATION SYSTEM

(51) International classification	:G09G0003360000, H04L0001000000, G01N0035100000, C12Q0001688600, G01N0033500000	(71)Name of Applicant : 1)BRIGHTON TECHNOLOGIES, LLC Address of Applicant :5129 Kieley Place Cincinnati, OH 45217 U.S.A.
(31) Priority Document No	:62/701061	(72)Name of Inventor :
(32) Priority Date	:20/07/2018	1)KOVAL, Richard David
(33) Name of priority country	:U.S.A.	2)JEAN-GILLES, Guyrandy
(86) International Application No	:PCT/US2019/042700	3)GILPIN, Andrew Davison
Filing Date	:19/07/2019	4)GEREN, Michael Anthony
(87) International Publication No	:WO 2020/018967	5)DILLINGHAM, Raymond Giles
(61) Patent of Addition to Application Number	:NA	6)BARRY, Timothy James
Filing Date	:NA	
(62) Divisional to Application Number	:NA	
Filing Date	:NA	

(57) Abstract :

A method and apparatus for collecting sample data from a liquid droplet dispensation system is provided.

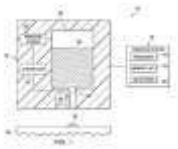

No. of Pages : 12 No. of Claims : 18

(54) Title of the invention : METHOD FOR TRANSMITTING DATA IN INTERNET OF VEHICLES AND TERMINAL DEVICE

(51) International classification	:H04W0072040000, H04L0029080000, H04L0005000000, H04W0076140000, H04W0072120000	(71)Name of Applicant : 1)GUANGDONG OPPO MOBILE TELECOMMUNICATIONS CORP., LTD. Address of Applicant :No.18 Haibin Road, Wusha, Chang'an Dongguan, Guangdong 523860 China
(31) Priority Document No	:NA	(72)Name of Inventor :
(32) Priority Date	:NA	1)LU, Qianxi
(33) Name of priority country	:NA	2)LIN, Hwei-Ming
(86) International Application No	:PCT/CN2018/094680	
Filing Date	:05/07/2018	
(87) International Publication No	:WO 2020/006736	
(61) Patent of Addition to Application Number	:NA	
Filing Date	:NA	
(62) Divisional to Application Number	:NA	
Filing Date	:NA	

(57) Abstract :

A method for transmitting data in an Internet of Vehicles and a terminal device, allowing the determination of a resource used for multiple transmissions of a sidelink, and favoring an increase in the reliability of data transmissions. The method comprises: a first terminal receives first control information transmitted by a second terminal, the first control information being used for determining resource information used for multiple transmissions of a sidelink; and the first terminal determines, on the basis of the first control information, a resource used for multiple transmissions of the sidelink.



No. of Pages : 34 No. of Claims : 20

(12) PATENT APPLICATION PUBLICATION

(21) Application No.202127004522 A

(19) INDIA

(22) Date of filing of Application :02/02/2021

(43) Publication Date : 11/06/2021

(54) Title of the invention : RANDOM ACCESS METHOD, TERMINAL DEVICE, AND NETWORK DEVICE

(51) International classification :H04W0074080000,
H04W0072040000,
H04W0074000000,
H04W0076110000,
H04W0072140000

(31) Priority Document No :201810846902.5

(32) Priority Date :27/07/2018

(33) Name of priority country :China

(86) International Application No :PCT/CN2019/097929
Filing Date :26/07/2019

(87) International Publication No :WO 2020/020352

(61) Patent of Addition to Application Number :NA
Filing Date :NA

(62) Divisional to Application Number :NA
Filing Date :NA

(71)Name of Applicant :
1)GUANGDONG OPPO MOBILE TELECOMMUNICATIONS CORP., LTD.
Address of Applicant :NO.18, Haibin Road, Wusha, Chang'an Dongguan, Guangdong 523860 China

(72)Name of Inventor :
1)XU, Weijie

(57) Abstract :

Embodiments of the present application provide a random access method, a terminal device, and a network device. During a random access process, the terminal device sends a preamble sequence and uplink information in MSG 1 and receives a random access response of the network device in MSG 2, thereby implementing random access by means of a two-step random access process and reducing time delay generated in the random access process. The method comprises: a terminal device sending a first preamble sequence and first uplink information on a first PRACH resource; and the terminal device receiving a first PDCCH scrambled by a first RA-RNTI, and implementing a subsequent random access process on the basis of a reception state of the first PDCCH, wherein the first RA-RNTI is obtained on the basis of the first PRACH resource.

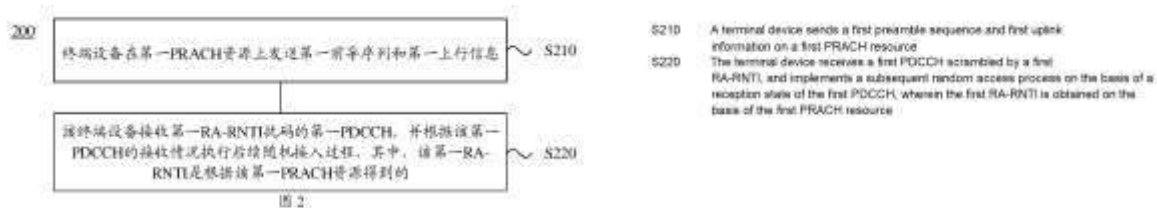

No. of Pages : 28 No. of Claims : 36

CONTINUED TO PART- 2

(12) PATENT APPLICATION PUBLICATION

(21) Application No.202241021103 A

(19) INDIA

(22) Date of filing of Application :08/04/2022

(43) Publication Date : 29/04/2022

(54) Title of the invention : ARTIFICIAL INTELLIGENCE VOICE ASSISTANCE FOR COMPUTERS USING PYTHON

(51) International classification :G06N0005020000, G06N0003000000, G10L0015260000, G06N0020000000, G09B0019000000

(86) International Application No :NA
 Filing Date :NA

(87) International Publication No : NA

(61) Patent of Addition to Application Number :NA
 Filing Date :NA

(62) Divisional to Application Number :NA
 Filing Date :NA

(71)Name of Applicant :

1)HINDUSTHAN COLLEGE OF ENGINEERING AND TECHNOLOGY

Address of Applicant :HINDUSTHAN COLLEGE OF ENGINEERING AND TECHNOLOGY, VALLEY CAMPUS, POLLACHI HIGHWAY, COIMBATORE, TAMIL NADU, INDIA - 641032. -----

Name of Applicant : NA

Address of Applicant : NA

(72)Name of Inventor :

1)Dr. I. JASMINE SELVAKUMARI JEYA

Address of Applicant :PROFESSOR & HEAD-IT, HINDUSTHAN COLLEGE OF ENGINEERING AND TECHNOLOGY, VALLEY CAMPUS, POLLACHI HIGHWAY, COIMBATORE, TAMIL NADU, INDIA - 641032. -----

2)Mr. C.D. PREMKUMAR

Address of Applicant :ASSISTANT PROFESSOR/IT, HINDUSTHAN COLLEGE OF ENGINEERING AND TECHNOLOGY, VALLEY CAMPUS, POLLACHI HIGHWAY, COIMBATORE, TAMIL NADU, INDIA - 641032. -----

3)AKASH K

Address of Applicant :HINDUSTHAN COLLEGE OF ENGINEERING AND TECHNOLOGY, VALLEY CAMPUS, POLLACHI HIGHWAY, COIMBATORE, TAMIL NADU, INDIA - 641032. -----

4)ARUMUGAM S

Address of Applicant :HINDUSTHAN COLLEGE OF ENGINEERING AND TECHNOLOGY, VALLEY CAMPUS, POLLACHI HIGHWAY, COIMBATORE, TAMIL NADU, INDIA - 641032. -----

5)KAVIYARASAN K

Address of Applicant :HINDUSTHAN COLLEGE OF ENGINEERING AND TECHNOLOGY, VALLEY CAMPUS, POLLACHI HIGHWAY, COIMBATORE, TAMIL NADU, INDIA - 641032. -----

6)LOKESH KUMAR G. K

Address of Applicant :HINDUSTHAN COLLEGE OF ENGINEERING AND TECHNOLOGY, VALLEY CAMPUS, POLLACHI HIGHWAY, COIMBATORE, TAMIL NADU, INDIA - 641032. -----

(57) Abstract :

■ AI is the core specialization of making smart machines, especially computer , programs. It relates with the familiar task of using computers to understand human , . intelligence.-AI is broadly classified the study of computations that permit for ' . perception, reason and action. This paper gives an overview idea of a personal-assistant for Windows based systems. The system draws its inspiration from 'virtual assistants like Cortana for Windows and Siri for iOS. It has been designed to 'provide-a user-friendly interface for carrying out a variety of tasks by employing certain well-defined commands. As a personal assistant, this paper ■focuses upon assistance of end-user with day-to-day activities like general human ■ ■ • conversation, searching queries on Google, searching for videos, retrieving • images, live weather conditions, word meanings, searching for medicine details, health recommendations based on symptoms and reminding the user about the scheduled events and tasks. The user statements/commands are analyzed with the - help.of machine learning to give an optimal solution.

No. of Pages : 5 No. of Claims : 5

(54) Title of the invention : ARTIFICIAL REGULAR ELDERLY ASSISTANCE AND CARE USING IOT AS A BOON FOR WORK PRONE CHILDREN

(51) International classification :G08B0021040000, H04L0029060000, H04L0029080000, G06Q0050220000, G10L0015220000

(86) International Application No :NA
 Filing Date :NA

(87) International Publication No : NA

(61) Patent of Addition to Application Number :NA
 Filing Date :NA

(62) Divisional to Application Number :NA
 Filing Date :NA

(71)Name of Applicant :
1)Hindusthan Institute of Technology
 Address of Applicant :Hindusthan Institute of Technology, Valley Campus, Pollachi Highway, Coimbatore, Tamilnadu, India 641032. -----

Name of Applicant : NA
 Address of Applicant : NA

(72)Name of Inventor :
1)Dr.C.Natarajan
 Address of Applicant :Professor/MECH, Hindusthan Institute of Technology, Valley Campus, Pollachi Highway, Coimbatore, Tamilnadu, India, Pin code 641032. -----

2)Mr. Arun R
 Address of Applicant :Assistant Professor/CSE, Hindusthan Institute of Technology, Valley Campus, Pollachi Highway, Coimbatore, Tamilnadu, India, Pin code 641032. -----

--

3)Dr. A. Jameer Basha
 Address of Applicant :Professor & Head/CSE, Hindusthan Institute of Technology, Valley Campus, Pollachi Highway, Coimbatore, Tamilnadu, India, Pin code 641032. -----

--

4)Dr. R. Kala
 Address of Applicant :Assistant Professor/CSE, Hindusthan Institute of Technology, Valley Campus, Pollachi Highway, Coimbatore, Tamilnadu, India, Pin code 641032. -----

--

5)Ms. Gomathi P
 Address of Applicant :Assistant Professor/CSE, Hindusthan Institute of Technology, Valley Campus, Pollachi Highway, Coimbatore, Tamilnadu, India, Pin code 641032. -----

--

6)Ms. R. T. Subhalakshmi
 Address of Applicant :Assistant Professor/CSE, Hindusthan Institute of Technology, Valley Campus, Pollachi Highway, Coimbatore, Tamilnadu, India, Pin code 641032. -----

--

7)Ms. M. Ramya Devi
 Address of Applicant :Assistant Professor/CSE, Hindusthan College of Engineering and Technology, Valley Campus, Pollachi Highway, Coimbatore, Tamilnadu, India, Pin code 641032. -----

8)Dr. I. Jasmine Selvakumari Jeya
 Address of Applicant :Professor & Head/IT, Hindusthan College of Engineering and Technology, Valley Campus, Pollachi Highway, Coimbatore, Tamilnadu, India, Pin code 641032. -----

9)Ms. V. Pradeeba
 Address of Applicant :Assistant Professor/CSE, Hindusthan Institute of Technology, Valley Campus, Pollachi Highway, Coimbatore, Tamilnadu, India, Pin code 641032. -----

(12) PATENT APPLICATION PUBLICATION

(21) Application No.202241021084 A

(19) INDIA

(22) Date of filing of Application :08/04/2022

(43) Publication Date : 29/04/2022

(54) Title of the invention : BLOCK CHAIN BASED PRIVACY PRESERVATION IN CLOUD ENVIRONMENT

(51) International classification :G09B0021000000, A61H0003060000, G10L0013000000, G09B0029000000, G09B0021020000

(86) International Application No :NA
Filing Date :NA

(87) International Publication No : NA

(61) Patent of Addition to Application Number :NA
Filing Date :NA

(62) Divisional to Application Number :NA
Filing Date :NA

(71)Name of Applicant :

1)Hindusthan College of Engineering and Technology

Address of Applicant :Hindusthan College of Engineering and Technology, Valley Campus, Pollachi Highway, Coimbatore, Tamilnadu, India 641032. -----

Name of Applicant : NA

Address of Applicant : NA

(72)Name of Inventor :

1)Dr.I.Jasmin Selvakumari Jeya

Address of Applicant :Hindusthan College of Engineering and Technology, Valley Campus, Pollachi Highway, Coimbatore, Tamilnadu, India 641032. -----

2)Dr.B.Gomathi

Address of Applicant :Associate Professor/ IT, Hindusthan College of Engineering and Technology, Valley Campus, Pollachi Highway, Coimbatore, Tamilnadu, India 641032. -----

3)Hariharan M

Address of Applicant :Hindusthan College of Engineering and Technology, Valley Campus, Pollachi Highway, Coimbatore, Tamilnadu, India 641032. -----

4)Hariharan R

Address of Applicant :Hindusthan College of Engineering and Technology, Valley Campus, Pollachi Highway, Coimbatore, Tamilnadu, India 641032. -----

5)Karthick Raja.J

Address of Applicant :Hindusthan College of Engineering and Technology, Valley Campus, Pollachi Highway, Coimbatore, Tamilnadu, India 641032. -----

6)Krithick Vasan S

Address of Applicant :Hindusthan College of Engineering and Technology, Valley Campus, Pollachi Highway, Coimbatore, Tamilnadu, India 641032. -----

(57) Abstract :

Annexure III One of the most prevalent issues that many blind and visually impaired people have is coping with their handicap on a daily basis. Braille, reading glasses, and a walking stick are just a few of the tools available to assist visually impaired people in their daily lives. With the advent of technology, a common Android Smartphone with particular applications can assist visually impaired and blind persons in their daily activities. As a result, the best custom-made application to assist visually impaired people has been implemented. The proposed application includes features such as GPS location identification, sending alert messages to selected contacts to ensure an individual's safety, an additional scheduling facility that alarms the user via voice, text, and vibration mode, and converting text in messages to voice data for the user's convenience.

No. of Pages : 5 No. of Claims : 5

(12) PATENT APPLICATION PUBLICATION

(21) Application No.202241021451 A

(19) INDIA

(22) Date of filing of Application :11/04/2022

(43) Publication Date : 29/04/2022

(54) Title of the invention : CODE TRACKER-A LIGHTWEIGHT APPROACH TO TRACK AND PROTECT AUTHORIZATION CODES IN SMS MESSAGES

(51) International classification :G06Q0020380000, G06Q0020320000, G06Q0020100000, G06Q0040020000, G06Q0050000000

(86) International Application No :NA
Filing Date :NA

(87) International Publication No : NA

(61) Patent of Addition to Application Number :NA
Filing Date :NA

(62) Divisional to Application Number :NA
Filing Date :NA

(71)Name of Applicant :
1)HINDUSTHAN COLLEGE OF ENGINEERING AND TECHNOLOGY
 Address of Applicant :HINDUSTHAN COLLEGE OF ENGINEERING AND TECHNOLOGY, VALLEY CAMPUS, POLLACHI HIGHWAY, COIMBATORE, TAMIL NADU, INDIA - 641032. -----
Name of Applicant : NA
Address of Applicant : NA

(72)Name of Inventor :
1)Dr. I. JASMINE SELVAKUMARI JEYA
 Address of Applicant :PROFESSOR & HEAD-IT, HINDUSTHAN COLLEGE OF ENGINEERING AND TECHNOLOGY, VALLEY CAMPUS, POLLACHI HIGHWAY, COIMBATORE, TAMIL NADU, INDIA - 641032. -----
2)Ms. R. AMUDHA
 Address of Applicant :ASSISTANT PROFESSOR/IT, HINDUSTHAN COLLEGE OF ENGINEERING AND TECHNOLOGY, VALLEY CAMPUS, POLLACHI HIGHWAY, COIMBATORE, TAMIL NADU, INDIA - 641032. -----
3)PRAVEEN IYYAPPAN R
 Address of Applicant :HINDUSTHAN COLLEGE OF ENGINEERING AND TECHNOLOGY, VALLEY CAMPUS, POLLACHI HIGHWAY, COIMBATORE, TAMIL NADU, INDIA - 641032. -----
4)THIRUMAL J
 Address of Applicant :HINDUSTHAN COLLEGE OF ENGINEERING AND TECHNOLOGY, VALLEY CAMPUS, POLLACHI HIGHWAY, COIMBATORE, TAMIL NADU, INDIA - 641032. -----
5)VIJAY M
 Address of Applicant :HINDUSTHAN COLLEGE OF ENGINEERING AND TECHNOLOGY, VALLEY CAMPUS, POLLACHI HIGHWAY, COIMBATORE, TAMIL NADU, INDIA - 641032. -----
6)VIMAL KARTHICK S
 Address of Applicant :HINDUSTHAN COLLEGE OF ENGINEERING AND TECHNOLOGY, VALLEY CAMPUS, POLLACHI HIGHWAY, COIMBATORE, TAMIL NADU, INDIA - 641032. -----

(57) Abstract :
 Mobile apps have brought tremendous impact to businesses, social, and lifestyle in recent years. Various app markets offer a wide range of apps from entertainment, business, health care and social life.' Many online banking services are developed in worldwide and mostly using the . OTP SMS to transact the payment from the user bank, but that OTP is traced out by the : unauthorized apps. More researches are carried out to secure the OTP SMS from the unauthorized app,then also can't protect the .OTP from anonymous user apps. To solve this problem, and protect the SMS, we proposed the Code Inject method, which inject the code into _: the OTP. The OTP sending through the SMS is not the original OTP, it is modified OTP by Code Inject method. The authorized apps only have the technique to get the original OTP from the -. modified OTP. With the modified OTP, the app can't transact the amount from bank. Code Inject method, consists of Operation function choose and the critical number generate, this will generate 'the modified OTP for the original OTP.

No. of Pages : 5 No. of Claims : 5

(54) Title of the invention : COMPUTER AIDED EMERGENCY SERVICE SYSTEM

<p>(51) International classification :G08B0025010000, G16H0080000000, G06Q0050220000, H04M0011040000, G01S0005000000</p> <p>(86) International Application No :NA Filing Date :NA</p> <p>(87) International Publication No : NA</p> <p>(61) Patent of Addition to Application Number :NA Filing Date :NA</p> <p>(62) Divisional to Application Number :NA Filing Date :NA</p>	<p>(71)Name of Applicant : 1) HINDUSTHAN COLLEGE OF ENGINEERING AND TECHNOLOGY Address of Applicant :HINDUSTHAN COLLEGE OF ENGINEERING AND TECHNOLOGY, VALLEY CAMPUS, POLLACHI HIGHWAY, COIMBATORE, TAMIL NADU, INDIA - 641032. ----- Name of Applicant : NA Address of Applicant : NA</p> <p>(72)Name of Inventor : 1)Dr. I. JASMINE SELVAKUMARI JEYA Address of Applicant : PROFESSOR & HEAD-IT, HINDUSTHAN COLLEGE OF ENGINEERING AND TECHNOLOGY, VALLEY CAMPUS, POLLACHI HIGHWAY, COIMBATORE, TAMIL NADU, INDIA - 641032. ----- 2)Ms. M. INDIRANI Address of Applicant :ASSISTANT PROFESSOR/IT, HINDUSTHAN COLLEGE OF ENGINEERING AND TECHNOLOGY, VALLEY CAMPUS, POLLACHI HIGHWAY, COIMBATORE, TAMIL NADU, INDIA - 641032. ----- 3)SUJITHKUMAR T Address of Applicant :HINDUSTHAN COLLEGE OF ENGINEERING AND TECHNOLOGY, VALLEY CAMPUS, POLLACHI HIGHWAY, COIMBATORE, TAMIL NADU, INDIA - 641032. ----- 4)TAMILARASU V Address of Applicant :HINDUSTHAN COLLEGE OF ENGINEERING AND TECHNOLOGY, VALLEY CAMPUS, POLLACHI HIGHWAY, COIMBATORE, TAMIL NADU, INDIA - 641032. ----- 5)VIGNESH C Address of Applicant :HINDUSTHAN COLLEGE OF ENGINEERING AND TECHNOLOGY, VALLEY CAMPUS, POLLACHI HIGHWAY, COIMBATORE, TAMIL NADU, INDIA - 641032. ----- 6)VIGNESH K Address of Applicant :HINDUSTHAN COLLEGE OF ENGINEERING AND TECHNOLOGY, VALLEY CAMPUS, POLLACHI HIGHWAY, COIMBATORE, TAMIL NADU, INDIA - 641032. -----</p>
---	--

(57) Abstract :

The large numbers of sick persons in different diseases are very dreaded, and when there isn't succor at the proper time and in the type the sick person need it that makes us lose person. This system offers a succoring system controlled by the patient based on the patients' location. In this emergency system the person will send SMS contains his ID and coordinates (Longitude and Latitude) via Global Positioning System (GPS) network to the web server, in this step the server will locate the sick person on Google map and retrieve the person's information from the database which is stored by the hospital employees. Based on these information our system will send succoring facility and at the same time informing the hospital, relatives and doctor. About that emergency person case information using the SMS and e-mail. This system relied on the dedicated tracking technology to identify the location of the patient. These dedicated alert systems used Global Positioning System GPS to provide the tracking-facility. The system allow the user's mobility to be tracked using dedicated GPS or mobile phone which are equipped with an internal GPS receiver and a GPRS transmitter, i.e. most of the applications so far use a handheld GPS receiver device for tracking the location, and ISP are busy in the interval of tracking. To overcome the problems above and to enhance the performance, throughput, of this type of system, the motivation is reached to system for succoring patients can achieve easy registration (from their homes) can select the nearest Emergency Service Center (ESC) when the patient need a succoring in emergency cases. wherever her/his location the succoring facility can reach to her/his. The proposed system is the first tracking system using mobile GIS based on webservice technology to offer online succoring but really works only when the patient sends request for succoring.

No. of Pages : 5 No. of Claims : 5

(12) PATENT APPLICATION PUBLICATION

(21) Application No.202241020878 A

(19) INDIA

(22) Date of filing of Application :07/04/2022

(43) Publication Date : 29/04/2022

(54) Title of the invention : DETECTION OF ANONYMOUS OBJECTS FOR SURVEILLANCE SYSTEM USING MACHINE LEARNING

<p>(51) International classification :H04N0007180000, G08B0013196000, G06K0009000000, G08B0025000000, G08B0025080000</p> <p>(86) International Application No :NA Filing Date :NA</p> <p>(87) International Publication No : NA</p> <p>(61) Patent of Addition to Application Number :NA Filing Date :NA</p> <p>(62) Divisional to Application Number :NA Filing Date :NA</p>	<p>(71)Name of Applicant : 1)Hindusthan College of Engineering and Technology Address of Applicant :Hindusthan College of Engineering and Technology, Valley Campus, Pollachi Highway, Coimbatore, Tamilnadu, India 641032. -----</p> <p>Name of Applicant : NA Address of Applicant : NA</p> <p>(72)Name of Inventor : 1)Dr.I.Jasmin Selvakumari Jeya Address of Applicant :Professor & Head - IT, Hindusthan College of Engineering and Technology, Valley Campus, Pollachi Highway, Coimbatore, Tamilnadu, India 641032. -----</p> <p>2)Mr.S.Karthic Address of Applicant :Assistant Professor/ IT, Hindusthan College of Engineering and Technology, Valley Campus, Pollachi Highway, Coimbatore, Tamilnadu, India 641032. -----</p> <p>3)Rafiq J Address of Applicant :Hindusthan College of Engineering and Technology, Valley Campus, Pollachi Highway, Coimbatore, Tamilnadu, India 641032. -----</p> <p>4)Sajeshpraveen R Address of Applicant :Hindusthan College of Engineering and Technology, Valley Campus, Pollachi Highway, Coimbatore, Tamilnadu, India 641032. -----</p> <p>5)Sakthivel M Address of Applicant :Hindusthan College of Engineering and Technology, Valley Campus, Pollachi Highway, Coimbatore, Tamilnadu, India 641032. -----</p> <p>6)Tamilarasan P Address of Applicant :Hindusthan College of Engineering and Technology, Valley Campus, Pollachi Highway, Coimbatore, Tamilnadu, India 641032. -----</p>
---	---

(57) Abstract :

Annexure 3 The approach in this project ensures the security system for usage in places like households and the security systems for the small companies which need to provide a good and secure work environment. Due to the increase in crime rate day by day we are moving towards a better security system that is very essential for us. The objective of this project is to design a high security system. This system protects the properties from someone who are not intended to access it. Anti-theft security system has been launched for many years but most of them are just a CCTV, IP camera or door sensor alert system. It could be more efficient with uses of face recognition and motion detectors. The design of the anti-theft security system is based on human face recognition and remote monitoring technology. A mobile application and image processing technique LBP based approach have been involved in this system. Face recognition will only start to function at a particular time which was already loaded and automated by the user. Here we are presenting a security system which includes capturing of images along with the alert message and photo taken will be sent to the owner's mobile phone via SMS and phone calls will also be triggered by SMS notification to the particular phone numbers. When the face recognition algorithms detect a stranger comes near the door and also a buzzer will be triggered to act as an alarm system. Owner can watch the camera with the application. It also sends an email to the prescribed mail id. This security system gives the total count of persons in the home. The loads can also be controlled automatically. This will help to reduce unnecessary wastage of power and memory. This security system is designed for actual use in anti-theft purposes using python which includes so many essential features according to the user's necessity.

No. of Pages : 5 No. of Claims : 5

(12) PATENT APPLICATION PUBLICATION

(21) Application No.202241021449 A

(19) INDIA

(22) Date of filing of Application :11/04/2022

(43) Publication Date : 29/04/2022

(54) Title of the invention : DRIVER'S ATTENTION MONITORING SYSTEM

(51) International classification :G06K0009000000, G08B0021060000, A61B0005180000, A61B0005000000, B60K0028060000
(86) International Application No :NA
Filing Date :NA
(87) International Publication No : NA
(61) Patent of Addition to Application Number :NA
Filing Date :NA
(62) Divisional to Application Number :NA
Filing Date :NA

(71)Name of Applicant :

1) HINDUSTHAN COLLEGE OF ENGINEERING AND TECHNOLOGY

Address of Applicant : HINDUSTHAN COLLEGE OF ENGINEERING AND TECHNOLOGY, VALLEY CAMPUS, POLLACHI HIGHWAY, COIMBATORE, TAMIL NADU, INDIA - 641032. -----

Name of Applicant : NA

Address of Applicant : NA

(72)Name of Inventor :

1)Dr. I. JASMINE SELVAKUMARI JEYA

Address of Applicant :PROFESSOR & HEAD-IT, HINDUSTHAN COLLEGE OF ENGINEERING AND TECHNOLOGY, VALLEY CAMPUS, POLLACHI HIGHWAY, COIMBATORE, TAMIL NADU, INDIA - 641032. -----

2)Ms. N. YAMUNA

Address of Applicant :ASSISTANT PROFESSOR/ IT, HINDUSTHAN COLLEGE OF ENGINEERING AND TECHNOLOGY, VALLEY CAMPUS, POLLACHI HIGHWAY, COIMBATORE, TAMIL NADU, INDIA - 641032. -----

3)GOWSALYA P

Address of Applicant :HINDUSTHAN COLLEGE OF ENGINEERING AND TECHNOLOGY, VALLEY CAMPUS, POLLACHI HIGHWAY, COIMBATORE, TAMIL NADU, INDIA - 641032. -----

4)NILAVARASI S

Address of Applicant :HINDUSTHAN COLLEGE OF ENGINEERING AND TECHNOLOGY, VALLEY CAMPUS, POLLACHI HIGHWAY, COIMBATORE, TAMIL NADU, INDIA - 641032. -----

(57) Abstract :

Drowsiness of drivers is one of the significant cause of road accidents. Every year, there is an increase in the amount of deaths and fatal injuries globally. By detecting the driver's drowsiness, road accidents can be reduced. This paper describes a machine learning approach for drowsiness detection. Face detection is employed to locate the regions of the driver's eyes, which are used as the templates for eye tracking in subsequent frames. Finally, the tracked eye's images are used for drowsiness detection in order to generate warning alarms. This proposed approach has three stages: detecting Face, detecting Eyes and detecting drowsiness. Image processing is used to recognize the face of the driver and then its extracts the image of the eyes of the driver for detection of drowsiness. The HAAR face detection algorithm takes as captured frames of image and then the detected face is considered as output. Next, CHT is used for tracking eyes from the detected face. Using EAR (Eye Aspect Ratio) the eye state is detected. The proposed system was tested by implementing the proposed approach using vgg!6 algorithm to detect driver drowsiness.

No. of Pages : 5 No. of Claims : 5

(12) PATENT APPLICATION PUBLICATION

(21) Application No.202241020875 A

(19) INDIA

(22) Date of filing of Application :07/04/2022

(43) Publication Date : 29/04/2022

(54) Title of the invention : FACE RECOGNITION USING LOCAL BINARY PATTERN HISTOGRAM ALGORITHM

(51) International classification :G06K0009000000, G06K0009460000, G06K0009620000, G07C0001100000, G07C0009280000

(86) International Application No :NA
Filing Date :NA

(87) International Publication No : NA

(61) Patent of Addition to Application Number :NA
Filing Date :NA

(62) Divisional to Application Number :NA
Filing Date :NA

(71)Name of Applicant :

1)HINDUSTHAN COLLEGE OF ENGINEERING AND TECHNOLOGY

Address of Applicant :Hindusthan College of Engineering and Technology, Valley Campus, Pollachi Highway, Coimbatore, Tamilnadu, India 641032. -----

Name of Applicant : NA

Address of Applicant : NA

(72)Name of Inventor :

1)Dr.I.Jasmin Selvakumari Jeya

Address of Applicant :Professor & Head - IT, Hindusthan College of Engineering and Technology, Valley Campus, Pollachi Highway, Coimbatore, Tamilnadu, India 641032. -----

2)Dr.D.Rasi

Address of Applicant :Associate Professor/IT, Hindusthan College of Engineering and Technology, Valley Campus, Pollachi Highway, Coimbatore, Tamilnadu, India 641032. -----

3)Abdularies M

Address of Applicant :Hindusthan College of Engineering and Technology, Valley Campus, Pollachi Highway, Coimbatore, Tamilnadu, India 641032. -----

4)Kevin K S

Address of Applicant :Hindusthan College of Engineering and Technology, Valley Campus, Pollachi Highway, Coimbatore, Tamilnadu, India 641032. -----

5)Mohamed Shafeek M

Address of Applicant :Hindusthan College of Engineering and Technology, Valley Campus, Pollachi Highway, Coimbatore, Tamilnadu, India 641032. -----

6)Nandhakumar R

Address of Applicant :Hindusthan College of Engineering and Technology, Valley Campus, Pollachi Highway, Coimbatore, Tamilnadu, India 641032. -----

(57) Abstract :

Annexure 3 Face recognition using Local Binary Pattern Histogram (LBPH) algorithm is used for marking attendance automatically without human interruption. The science and technology emerges day to day. The recognition of individual person was done by fingerprint, signatures etc. In that way, a new method to identify an individual is done by face recognition using web cameras. This is made possible by face recognition algorithms such as Local Binary Pattern Histogram algorithm in OpenCV package. The system is tested under varying lighting conditions, various facial expressions, presence of partial faces in densely populated classrooms and presence or absence of beard and spectacles. This methodology helps to get the datasets of faces in various positions and train those dataset and finally check the identification process. Then the webcam is opened and trained data is verified with the individual. The algorithm scans the face and makes the recognition process and displays the name of the individual.

No. of Pages : 5 No. of Claims : 5

(54) Title of the invention : FAKE PRODUCT REVIEW MONITORNG SYSTEM

(51) International classification :G06Q0030020000, G06Q0030000000, G06F0040205000, G06F0040258000, G06F0040300000

(86) International Application No :NA
 Filing Date :NA

(87) International Publication No : NA

(61) Patent of Addition to Application Number :NA
 Filing Date :NA

(62) Divisional to Application Number :NA
 Filing Date :NA

(71)**Name of Applicant :**
1)HINDUSTHAN COLLEGE OF ENGINEERING AND TECHNOLOGY
 Address of Applicant :HINDUSTHAN COLLEGE OF ENGINEERING AND TECHNOLOGY, VALLEY CAMPUS, POLLACHI HIGHWAY, COIMBATORE, TAMIL NADU, INDIA - 641032. -----

Name of Applicant : NA
Address of Applicant : NA

(72)**Name of Inventor :**
1)Dr. I. JASMINE SELVAKUMARI JEYA
 Address of Applicant :PROFESSOR & HEAD-IT, HINDUSTHAN COLLEGE OF ENGINEERING AND TECHNOLOGY, VALLEY CAMPUS, POLLACHI HIGHWAY, COIMBATORE, TAMIL NADU, INDIA - 641032. -----

2)Mr. N. ILAYARAJA
 Address of Applicant :ASSISTANT PROFESSOR/IT, HINDUSTHAN COLLEGE OF ENGINEERING AND TECHNOLOGY, VALLEY CAMPUS, POLLACHI HIGHWAY, COIMBATORE, TAMIL NADU, INDIA - 641032. -----

3)SIVASUBRAMANIAN M
 Address of Applicant :HINDUSTHAN COLLEGE OF ENGINEERING AND TECHNOLOGY, VALLEY CAMPUS, POLLACHI HIGHWAY, COIMBATORE, TAMIL NADU, INDIA - 641032. -----

4)SURYA PRAKASH. N
 Address of Applicant :HINDUSTHAN COLLEGE OF ENGINEERING AND TECHNOLOGY, VALLEY CAMPUS, POLLACHI HIGHWAY, COIMBATORE, TAMIL NADU, INDIA - 641032. -----

5)VASANTH KUMAR K
 Address of Applicant :HINDUSTHAN COLLEGE OF ENGINEERING AND TECHNOLOGY, VALLEY CAMPUS, POLLACHI HIGHWAY, COIMBATORE, TAMIL NADU, INDIA - 641032. -----

6)VIGNESH S
 Address of Applicant :HINDUSTHAN COLLEGE OF ENGINEERING AND TECHNOLOGY, VALLEY CAMPUS, POLLACHI HIGHWAY, COIMBATORE, TAMIL NADU, INDIA - 641032. -----

(57) Abstract :

•The importance and extent of online markets and e-commerce platforms is growing, and '■ many people use them to buy things. As a result, the number of product feedbacks is displayed in detail for users to evaluate the goods they are purchasing. This can also work against consumers - because users can often flood the review section with extreme opinions that can either help or hurt the product. As a result, we must be cautious because this can be done by the merchant to ■ boost the worth of his goods or by the consumer to lower the product's ratings. In general, review's can be divided into two categories: authentic and fraudulent. They frequently reuse or slightly revise the same-review for different products. This duplication can be divided into four categories, (1) duplicates from the same customer id on the same product, (2) duplicates from ' ■ different customer id on the same product, (3) duplicates from the same customer id on different ■ products-(4) duplicate from different user id on different products. The fake review detection will- compare the attributes and sentiments from the reviews' attributes with the attributes and sentiments from the other reviews' attributes, taking into account the similarity value between the two reviews. The' goal of this study is to discern between fraudulent product reviews and ■' authentic reviews in order to affect the general sentiment of the products. The proposed method .will save them time and effort by assisting users and businesses in quickly identifying spam from . ■ .- many perspectives, as well as assisting them in acquiring their important products from a reliable ■ site.-' ft is critical to deploy a robust detection algorithm to assure the credibility of reviews posted on a site. We don't summaries the reviews by rewriting parts of the original comments from the ' reviews'in-order to catch the important points, as is the case with traditional text summary. Our task is performedih steps: (1) while login the customer will be verified using his/her e-mail id; -.. (2) mining product features that have been commented on by customers; (3) identifying opinion '■ sentences me'ach review and deciding whether each comment positive or negative; (4) and while giving opinions if its fake then e-mail id is blocked; (5) summarizing the results.

No. of Pages : 5 No. of Claims : 5

(54) Title of the invention : ID CELLULAR AUTOMATA FOR IMAGE ENCRYPTION AND DECRYPTION

(51) International classification :H04L0009060000, G06T0001000000, G06F0021620000, H04L0029060000, H04B0001692000

(86) International Application No :NA
Filing Date :NA

(87) International Publication No : NA

(61) Patent of Addition to Application Number :NA
Filing Date :NA

(62) Divisional to Application Number :NA
Filing Date :NA

(71)Name of Applicant :**1)Hindusthan College of Engineering and Technology**

Address of Applicant :Hindusthan College of Engineering and Technology, Valley Campus, Pollachi Highway, Coimbatore, Tamilnadu, India 641032. -----

Name of Applicant : NA**Address of Applicant : NA****(72)Name of Inventor :****1)Dr.I.Jasmin Selvakumari Jeya**

Address of Applicant :Professor & Head - IT, Hindusthan College of Engineering and Technology, Valley Campus, Pollachi Highway, Coimbatore, Tamilnadu, India 641032. -----

2)Ms.M.Indirani

Address of Applicant :Assistant Professor/ IT, Hindusthan College of Engineering and Technology, Valley Campus, Pollachi Highway, Coimbatore, Tamilnadu, India 641032. -----

3)Aishwarya G

Address of Applicant :Hindusthan College of Engineering and Technology, Valley Campus, Pollachi Highway, Coimbatore, Tamilnadu, India 641032. -----

4)Jai Irin Mystica J

Address of Applicant :Hindusthan College of Engineering and Technology, Valley Campus, Pollachi Highway, Coimbatore, Tamilnadu, India 641032. -----

5)Lagumesh V

Address of Applicant :Hindusthan College of Engineering and Technology, Valley Campus, Pollachi Highway, Coimbatore, Tamilnadu, India 641032. -----

(57) Abstract :

Annexure 3 A digital image plays an important role in multimedia technology, it becomes more important for the user to maintain privacy. To provide such security and privacy to the user, image encryption is very important to protect from any unauthorised user access. However, simple encryption techniques are prone to attacks like statistical attacks, differential attacks. In this project, we propose a novel approach using the cellular automata with a block cipher mode of operation. Hash counter turns an n-bit block cipher into a tweakable block cipher that supports arbitrary variable input length which is no less than n bits. This Proposed algorithm has less computational time and high speed since it encrypts parallelly and inverse free. The HCTR is a strong tweakable pseudorandom permutation, when the underlying block cipher is a strong pseudorandom permutation. The Feistel Structure further improves the encryption process. The Analysis are conducted on the experiment such as Entropy, UACI, Histogram, Chi Square test are carried out, to prove the efficiency and security of the project. The experimental results prove that the proposed algorithm, despite its simplicity, can withstand several types of attacks through image encryption. The research results shed new light on the data security in the transmission of digital images.

No. of Pages : 4 No. of Claims : 5

(12) PATENT APPLICATION PUBLICATION

(21) Application No.202241021105 A

(19) INDIA

(22) Date of filing of Application :08/04/2022

(43) Publication Date : 29/04/2022

(54) Title of the invention : LOSE IT-A FITNESS COMPANION

(51) International classification :G16H0020300000, G09B0019000000, G16H0020600000, G09B0005020000, A63B0023120000

(86) International Application No :NA
Filing Date :NA

(87) International Publication No : NA

(61) Patent of Addition to Application Number :NA
Filing Date :NA

(62) Divisional to Application Number :NA
Filing Date :NA

(71)Name of Applicant :

1)HINDUSTHAN COLLEGE OF ENGINEERING AND TECHNOLOGY

Address of Applicant :HINDUSTHAN COLLEGE OF ENGINEERING AND TECHNOLOGY, VALLEY CAMPUS, POLLACHI HIGHWAY, COIMBATORE, TAMIL NADU, INDIA - 641032. -----

Name of Applicant : NA

Address of Applicant : NA

(72)Name of Inventor :

1)Dr. I. JASMINE SELVAKUMARI JEYA

Address of Applicant :PROFESSOR & HEAD-IT, HINDUSTHAN COLLEGE OF ENGINEERING AND TECHNOLOGY, VALLEY CAMPUS, POLLACHI HIGHWAY, COIMBATORE, TAMIL NADU, INDIA - 641032. -----

2)Ms. P. REVATHI

Address of Applicant :ASSISTANT PROFESSOR/IT, HINDUSTHAN COLLEGE OF ENGINEERING AND TECHNOLOGY, VALLEY CAMPUS, POLLACHI HIGHWAY, COIMBATORE, TAMIL NADU, INDIA - 641032. -----

3)AKASH R

Address of Applicant :HINDUSTHAN COLLEGE OF ENGINEERING AND TECHNOLOGY, VALLEY CAMPUS, POLLACHI HIGHWAY, COIMBATORE, TAMIL NADU, INDIA - 641032. -----

4)BHARATHI KANNAN S

Address of Applicant :HINDUSTHAN COLLEGE OF ENGINEERING AND TECHNOLOGY, VALLEY CAMPUS, POLLACHI HIGHWAY, COIMBATORE, TAMIL NADU, INDIA - 641032. -----

5)CHANDRASEKAR T S

Address of Applicant :HINDUSTHAN COLLEGE OF ENGINEERING AND TECHNOLOGY, VALLEY CAMPUS, POLLACHI HIGHWAY, COIMBATORE, TAMIL NADU, INDIA - 641032. -----

6)DIVAGAR M

Address of Applicant :HINDUSTHAN COLLEGE OF ENGINEERING AND TECHNOLOGY, VALLEY CAMPUS, POLLACHI HIGHWAY, COIMBATORE, TAMIL NADU, INDIA - 641032. -----

(57) Abstract :

.The Lose It! application gives the access towards the new technologies which has produced an- increase in the number of studies that try to evaluate themselves, towards the use of the fitness ■ application. The aim of this application is to perform a systematic review on the intention to use mobile application in a secured, scheduled and schematic manner. A total of 13 studies are analyzed that propose models for evaluating the use of the fitness applications by a sports enthusiast. This application regulates the accurate goal which has processed on a day all the hard work.and progress are calculated at a precised manner with the use of our calorie calculator we could add up the systematic details on the daily intake and their specific calories. This Lose It! application also has the exciting fun facts and breaks out the major myth on fitness lifestyle. The application provides the p.latform.to interact with the fitness expertise to handle daily workout and diet plan for both weight . • loss and weight gain as per strict procedure. This application provides the right path on fitness life and-lead a healthy lifestyle.

No. of Pages : 5 No. of Claims : 5

(12) PATENT APPLICATION PUBLICATION

(21) Application No.202241024449 A

(19) INDIA

(22) Date of filing of Application :26/04/2022

(43) Publication Date : 13/05/2022

(54) Title of the invention : MODELED REGION OF NON-INTEREST BASED SECURED AUTHENTICATE AND INDEXING OF LUNG COMPUTED TOMOGRAPHY IMAGES

<p>(51) International classification :A61B0006000000, A61B0006030000, G06T0011000000, G06Q0020220000, A61B0006020000</p> <p>(86) International Application No :NA Filing Date :NA</p> <p>(87) International Publication No : NA</p> <p>(61) Patent of Addition to Application Number :NA Filing Date :NA</p> <p>(62) Divisional to Application Number :NA Filing Date :NA</p>	<p>(71)Name of Applicant : 1)HINDUSTHAN COLLEGE OF ENGINEERING AND TECHNOLOGY Address of Applicant :HINDUSTHAN COLLEGE OF ENGINEERING AND TECHNOLOGY, VALLEY CAMPUS, POLLACHI HIGHWAY, COIMBATORE, TAMILNADU, INDIA, PIN CODE-641032. -----</p> <p>Name of Applicant : NA Address of Applicant : NA</p> <p>(72)Name of Inventor : 1)Dr. I. JASMINE SELVAKUMARI JEYA Address of Applicant :PROFESSOR & HEAD-IT, HINDUSTHAN COLLEGE OF ENGINEERING AND TECHNOLOGY, VALLEY CAMPUS, POLLACHI HIGHWAY, COIMBATORE, TAMILNADU, INDIA, PIN CODE-641032. ---- -----</p> <p>2)Dr. B. GOMATHI Address of Applicant :ASSOCIATE PROFESSOR/CSE, HINDUSTHAN COLLEGE OF ENGINEERING AND TECHNOLOGY, VALLEY CAMPUS, POLLACHI HIGHWAY, COIMBATORE, TAMILNADU, INDIA, PIN CODE-641032. ---- -----</p> <p>3)Dr. M. REVATHI Address of Applicant :ASSOCIATE PROFESSOR/CSE, HINDUSTHAN COLLEGE OF ENGINEERING AND TECHNOLOGY, VALLEY CAMPUS, POLLACHI HIGHWAY, COIMBATORE, TAMILNADU, INDIA, PIN CODE-641032. ---- -----</p> <p>4)Ms. C. JENCY Address of Applicant :ASSISTANT PROFESSOR/IT, HINDUSTHAN COLLEGE OF ENGINEERING AND TECHNOLOGY, VALLEY CAMPUS, POLLACHI HIGHWAY, COIMBATORE, TAMILNADU, INDIA, PIN CODE-641032. ---- -----</p>
---	---

(57) Abstract :

Medical images produced from different modalities are stored in image database. These databases should be safely moved over the public network with control viably and Medical images need to be transmitted with the patient's information without altering the image data. Medical image watermarking is a proper strategy utilized for improving security. Furthermore, validation of medical data, which is pivotal and utilized for additional deduction what's more, reference. The task centres on the investigation of medical image watermarking techniques for securing and validating medical data. Moreover, it covers calculation for utilization of water stamping procedure on. The objective of this chapter is to discuss Secured Indexing of Lung CT Image (SILI) which is a secured way of indexing the lung CT images with the patient information. Authentication is provided using the sender's logo information and the secret key is used for embedding the watermark into the host image. Watermark is embedded into the Region of Noninterest (RONI) of the lung CT image. RONI is identified by segmenting the lung tissue from the CT scan image.

No. of Pages : 5 No. of Claims : 5

(12) PATENT APPLICATION PUBLICATION

(21) Application No.202241020870 A

(19) INDIA

(22) Date of filing of Application :07/04/2022

(43) Publication Date : 29/04/2022

(54) Title of the invention : MULTI BANKING SYSTEM

(51) International classification :G07F0007100000, G06Q0020340000, G06Q0020400000, G07F0007080000, G06Q0020100000

(86) International Application No :NA
Filing Date :NA

(87) International Publication No : NA

(61) Patent of Addition to Application Number :NA
Filing Date :NA

(62) Divisional to Application Number :NA
Filing Date :NA

(71)Name of Applicant :

1)Hindusthan College of Engineering and Technology

Address of Applicant :Hindusthan College of Engineering and Technology, Valley Campus, Pollachi Highway, Coimbatore, Tamilnadu, India 641032. -----

Name of Applicant : NA

Address of Applicant : NA

(72)Name of Inventor :

1)Dr.I.Jasmine Selvakumari Jeya

Address of Applicant :Professor & Head - IT, Hindusthan College of Engineering and Technology, Valley Campus, Pollachi Highway, Coimbatore, Tamilnadu, India 641032. -----

2)Dr.D.Rasi

Address of Applicant :Associate Professor/IT, Hindusthan College of Engineering and Technology, Valley Campus, Pollachi Highway, Coimbatore, Tamilnadu, India 641032. -----

3)Rajkumar M

Address of Applicant :Hindusthan College of Engineering and Technology, Valley Campus, Pollachi Highway, Coimbatore, Tamilnadu, India 641032. -----

4)Ranjith K

Address of Applicant :Hindusthan College of Engineering and Technology, Valley Campus, Pollachi Highway, Coimbatore, Tamilnadu, India 641032. -----

5)Vijayakumar S

Address of Applicant :Hindusthan College of Engineering and Technology, Valley Campus, Pollachi Highway, Coimbatore, Tamilnadu, India 641032. -----

6)Sabarirajan K

Address of Applicant :Hindusthan College of Engineering and Technology, Valley Campus, Pollachi Highway, Coimbatore, Tamilnadu, India 641032. -----

(57) Abstract :

Annexure 3 Recently, each of the multi-function card systems has been continuously expanding its function, and almost to the acme. The implementation of bank-campus multi-function card system has realized the multi-win among banks, merchant stations, card owners and schools. However, these designs are confined to the connotative expansions of the system function, not the further optimize of the system. It often forms an integral part of a business transformation program addressing key banking issues. The system shall also be available for implementation in a wide range of banking operation scale, from small cooperative bank to large commercial bank. In traditional system, ATM terminal customer recognition systems only rely on bank cards, security pin number, and such identity verification methods which measures are not perfect and functions are too single and at times there are incidents where we forget ours security PIN number, lose our cards, cards get stolen, stolen PIN numbers. Secured Transaction Algorithm (STA) this algorithm used to card used secure banking process and itsall user Easley access system. The system shall also be enabled to easily operate in application-hosting business model, to reach the maximum availability of economic scale that will empower small-scale sharia-based business entities to participate in an integrated payment and transaction processing system.

No. of Pages : 5 No. of Claims : 5

(12) PATENT APPLICATION PUBLICATION

(21) Application No.202241020888 A

(19) INDIA

(22) Date of filing of Application :07/04/2022

(43) Publication Date : 29/04/2022

(54) Title of the invention : NATURAL LANGUAGE PROCESSING BASED CHAT BOT FOR HEALTH CARE SERVICES

(51) International classification :H04L0012580000, G06F0016953500, G06F0040200000, G10L0015220000, H04L0029080000

(86) International Application No :NA
 Filing Date :NA

(87) International Publication No : NA

(61) Patent of Addition to Application Number :NA
 Filing Date :NA

(62) Divisional to Application Number :NA
 Filing Date :NA

(71)Name of Applicant :
1)HINDUSTHAN COLLEGE OF ENGINEERING AND TECHNOLOGY
 Address of Applicant :HINDUSTHAN COLLEGE OF ENGINEERING AND TECHNOLOGY, VALLEY CAMPUS, POLLACHI HIGHWAY, COIMBATORE, TAMIL NADU, INDIA - 641032. -----

Name of Applicant : NA
Address of Applicant : NA

(72)Name of Inventor :
1)Dr. I. JASMINE SELVAKUMARI JEYA
 Address of Applicant :PROFESSOR & HEAD-IT, HINDUSTHAN COLLEGE OF ENGINEERING AND TECHNOLOGY, VALLEY CAMPUS, POLLACHI HIGHWAY, COIMBATORE, TAMIL NADU, INDIA - 641032. -----

2)Mr. M. GANESAN
 Address of Applicant :ASSISTANT PROFESSOR/IT, HINDUSTHAN COLLEGE OF ENGINEERING AND TECHNOLOGY, VALLEY CAMPUS, POLLACHI HIGHWAY, COIMBATORE, TAMIL NADU, INDIA - 641032. -----

3)SANTHOSH R
 Address of Applicant :HINDUSTHAN COLLEGE OF ENGINEERING AND TECHNOLOGY, VALLEY CAMPUS, POLLACHI HIGHWAY, COIMBATORE, TAMIL NADU, INDIA - 641032. -----

4)SHRI PRAKSH K
 Address of Applicant :HINDUSTHAN COLLEGE OF ENGINEERING AND TECHNOLOGY, VALLEY CAMPUS, POLLACHI HIGHWAY, COIMBATORE, TAMIL NADU, INDIA - 641032. -----

5)SIVARAAM R
 Address of Applicant :HINDUSTHAN COLLEGE OF ENGINEERING AND TECHNOLOGY, VALLEY CAMPUS, POLLACHI HIGHWAY, COIMBATORE, TAMIL NADU, INDIA - 641032. -----

6)TAMIL SELVAN M
 Address of Applicant :HINDUSTHAN COLLEGE OF ENGINEERING AND TECHNOLOGY, VALLEY CAMPUS, POLLACHI HIGHWAY, COIMBATORE, TAMIL NADU, INDIA - 641032. -----

(57) Abstract :
 Chat-bots aims to make a conversation between both Human and machine. The machine has been embedded knowledge to identify of the sentences and making a decision Itself as a response answer to a question. Chat-bots will be Completely based on a text-based user interface, allowing User to type commands and receive text as well as text to Speech response. Chat-bots are usually stateful services Remembering previous commands in order to provide Functionality. It can be utilized securely by an even larger Audience when chat-bots technology is integrated with Popular web services. The response principle is Matching the input sentence from a user. The User can ask Question any college-related activities through the chat-bot Without physically available. The System analyses the question and then answers to the user. The chat-bots consists of core and interface that is accessing the core. NLP is natural language Processing technologies are used for parsing and Tokenizing Stemming and filtering content of the complaint. Healthcare providers can use a chatbot dedicated to answering their patient's most commonly asked questions: Questions about insurance like covers, claims, documents, symptoms, business hours, and quick fixes can be communicated to patients through the Chatbot.

No. of Pages : 5 No. of Claims : 5

(12) PATENT APPLICATION PUBLICATION

(21) Application No.202241020892 A

(19) INDIA

(22) Date of filing of Application :07/04/2022

(43) Publication Date : 29/04/2022

(54) Title of the invention : ONLINE PRODUCT RANKING SYSTEM USING AGGREGATION AND FILTRATION

(51) International classification :G06Q0030020000, G06Q0030060000, G06Q0050300000, G06Q0010040000, G06Q0099000000

(86) International Application No :NA
 Filing Date :NA

(87) International Publication No : NA

(61) Patent of Addition to Application Number :NA
 Filing Date :NA

(62) Divisional to Application Number :NA
 Filing Date :NA

(71)Name of Applicant :

1)HINDUSTHAN COLLEGE OF ENGINEERING AND TECHNOLOGY

Address of Applicant :HINDUSTHAN COLLEGE OF ENGINEERING AND TECHNOLOGY, VALLEY CAMPUS, POLLACHI HIGHWAY, COIMBATORE, TAMIL NADU, INDIA - 641032. -----

Name of Applicant : NA

Address of Applicant : NA

(72)Name of Inventor :

1)Dr. I. JASMINE SELVAKUMARI JEYA

Address of Applicant :PROFESSOR & HEAD-IT, HINDUSTHAN COLLEGE OF ENGINEERING AND TECHNOLOGY, VALLEY CAMPUS, POLLACHI HIGHWAY, COIMBATORE, TAMIL NADU, INDIA - 641032. -----

2)Ms. T. SAKTHI SHREE

Address of Applicant :ASSISTANT PROFESSOR/ IT, HINDUSTHAN COLLEGE OF ENGINEERING AND TECHNOLOGY, VALLEY CAMPUS, POLLACHI HIGHWAY, COIMBATORE, TAMIL NADU, INDIA - 641032. -----

3) SARANYA S

Address of Applicant :HINDUSTHAN COLLEGE OF ENGINEERING AND TECHNOLOGY, VALLEY CAMPUS, POLLACHI HIGHWAY, COIMBATORE, TAMIL NADU, INDIA - 641032. -----

4)SIVARANJANI M

Address of Applicant :HINDUSTHAN COLLEGE OF ENGINEERING AND TECHNOLOGY, VALLEY CAMPUS, POLLACHI HIGHWAY, COIMBATORE, TAMIL NADU, INDIA - 641032. -----

5)PAVITHRA ANAND V

Address of Applicant :HINDUSTHAN COLLEGE OF ENGINEERING AND TECHNOLOGY, VALLEY CAMPUS, POLLACHI HIGHWAY, COIMBATORE, TAMIL NADU, INDIA - 641032. -----

6)SRISHA G

Address of Applicant :HINDUSTHAN COLLEGE OF ENGINEERING AND TECHNOLOGY, VALLEY CAMPUS, POLLACHI HIGHWAY, COIMBATORE, TAMIL NADU, INDIA - 641032. -----

(57) Abstract :

We propose an advanced products ranking analysis system, which provides a platform to registered users to rate a particular, or multiple products. Online product ranking system is a web application which consists of multiple products added by admin to review, to rate them. Online product ratings have significant impacts on consumers' purchase decisions. To support consumers' purchase decisions, how to rank the products through online ratings is a valuable research topic, while research concerning this issue is still relatively scarce. Hence the need arises to design an effective model to summarize the pros and cons of the product opinions, its features etc, so that consumers can quickly find products to their requirements and liking. The proposed system takes ratings of various users, based on their personal opinion, the system will specify whether the posted product is good, bad, or worst. System will use the database, will aggregate the ratings along with the already available aggregate in the database, and will rank the review. This application is also useful for the users who want to buy new products. This system helps to find out good products based on multiple user's positive ratings on a scale of 1 to 5.

No. of Pages : 5 No. of Claims : 5

(12) PATENT APPLICATION PUBLICATION

(21) Application No.202241021111 A

(19) INDIA

(22) Date of filing of Application :08/04/2022

(43) Publication Date : 29/04/2022

(54) Title of the invention : PRE-SCHEDULED ONLINE FOOD ORDERING MANAGEMENT SYSTEM

(51) International classification :G06Q0030060000, G06Q0050120000, G06Q0030020000, H04W0072120000, G07G0001140000

(86) International Application No :NA
Filing Date :NA

(87) International Publication No : NA

(61) Patent of Addition to Application Number :NA
Filing Date :NA

(62) Divisional to Application Number :NA
Filing Date :NA

(71)Name of Applicant :

1)Hindusthan College of Engineering and Technology

Address of Applicant :Hindusthan College of Engineering and Technology, Valley Campus, Pollachi Highway, Coimbatore, Tamilnadu, India 641032. -----

Name of Applicant : NA

Address of Applicant : NA

(72)Name of Inventor :

1)Dr.I.Jasmin Selvakumari Jeya

Address of Applicant :Professor & Head - IT, Hindusthan College of Engineering and Technology, Valley Campus, Pollachi Highway, Coimbatore, Tamilnadu, India 641032. -----

2)Mr.M.Sathish Kumar

Address of Applicant :Assistant Professor/ IT, Hindusthan College of Engineering and Technology, Valley Campus, Pollachi Highway, Coimbatore, Tamilnadu, India 641032. -----

3)Malarvanan A

Address of Applicant :Hindusthan College of Engineering and Technology, Valley Campus, Pollachi Highway, Coimbatore, Tamilnadu, India 641032. -----

4)Mohanabalaji S

Address of Applicant :Hindusthan College of Engineering and Technology, Valley Campus, Pollachi Highway, Coimbatore, Tamilnadu, India 641032. -----

5)Mohan Kanth.D

Address of Applicant :Hindusthan College of Engineering and Technology, Valley Campus, Pollachi Highway, Coimbatore, Tamilnadu, India 641032. -----

6)Moun Prasath R

Address of Applicant :Hindusthan College of Engineering and Technology, Valley Campus, Pollachi Highway, Coimbatore, Tamilnadu, India 641032. -----

(57) Abstract :

Annexure 3 The objective of the pre-scheduled online food ordering system is to automate the existing food ordering system by pre-scheduling the orders. The orders can be made for a month, a week or a day depending on the customer needs by the help of computerized equipment's and computer software fulfilling their requirements, so that their valuable data/information can be stored for a longer period with easy accessing and manipulation of the same. The above mentioned system will reduce the work of people by reducing their time being spent on the application for ordering the food each and every time. The main objective of this project is to order food online and to manage the details of food item, category, customer, order and payment details. The payment can be done at once either at the end or at the beginning.

No. of Pages : 5 No. of Claims : 5

(12) PATENT APPLICATION PUBLICATION

(21) Application No.202241020886 A

(19) INDIA

(22) Date of filing of Application :07/04/2022

(43) Publication Date : 29/04/2022

(54) Title of the invention : SECURED SOCIAL NETWORKING PLATFORM IN CLOUD COMPUTING

(51) International classification :H04L0029060000, G06F0021620000, G06F0021550000, G06F0021600000, G06K0019073000
(86) International Application No :NA
Filing Date :NA
(87) International Publication No : NA
(61) Patent of Addition to Application Number :NA
Filing Date :NA
(62) Divisional to Application Number :NA
Filing Date :NA

(71)Name of Applicant :

1) HINDUSTHAN COLLEGE OF ENGINEERING AND TECHNOLOGY

Address of Applicant :HINDUSTHAN COLLEGE OF ENGINEERING AND TECHNOLOGY, VALLEY CAMPUS, POLLACHI HIGHWAY, COIMBATORE, TAMIL NADU, INDIA - 641032. -----

Name of Applicant : NA

Address of Applicant : NA

(72)Name of Inventor :

1) Dr. I. JASMINE SELVAKUMARI JEYA

Address of Applicant : PROFESSOR & HEAD-IT, HINDUSTHAN COLLEGE OF ENGINEERING AND TECHNOLOGY, VALLEY CAMPUS, POLLACHI HIGHWAY, COIMBATORE, TAMIL NADU, INDIA - 641032. -----

2)Mr.M. GANESAN

Address of Applicant :ASSISTANT PROFESSOR/IT, HINDUSTHAN COLLEGE OF ENGINEERING AND TECHNOLOGY, VALLEY CAMPUS, POLLACHI HIGHWAY, COIMBATORE, TAMIL NADU, INDIA - 641032. -----

3)P.ARUNPRASATH

Address of Applicant :HINDUSTHAN COLLEGE OF ENGINEERING AND TECHNOLOGY, VALLEY CAMPUS, POLLACHI HIGHWAY, COIMBATORE, TAMIL NADU, INDIA - 641032. -----

4)CHANDRU D.R

Address of Applicant :HINDUSTHAN COLLEGE OF ENGINEERING AND TECHNOLOGY, VALLEY CAMPUS, POLLACHI HIGHWAY, COIMBATORE, TAMIL NADU, INDIA - 641032. -----

5)HARIHARAN. V

Address of Applicant :HINDUSTHAN COLLEGE OF ENGINEERING AND TECHNOLOGY, VALLEY CAMPUS, POLLACHI HIGHWAY, COIMBATORE, TAMIL NADU, INDIA - 641032. -----

6)MOHAMMED MAIDEEN NOWFAL V.A

Address of Applicant :HINDUSTHAN COLLEGE OF ENGINEERING AND TECHNOLOGY, VALLEY CAMPUS, POLLACHI HIGHWAY, COIMBATORE, TAMIL NADU, INDIA - 641032. -----

(57) Abstract :

Computing promises to significantly change the way we use computers and access and store our personal and business information. With these new computing and communications paradigms arise new data security challenges. Existing data protection mechanisms such as encryption have failed in preventing data theft attacks, especially those perpetrated by an insider to the server. We propose a different approach for securing data in the server using offensive decoy technology. We monitor data access in the cloud and detect abnormal data access patterns. When unauthorized access is suspected and then verified using challenge questions, we launch a disinformation attack by returning large amounts of decoy information to the attacker. This protects against the misuse of the user's real data. Experiments conducted in a local file setting provide evidence that this approach may provide unprecedented levels of user data security in a real world. Privacy is very important feature for some people, and social networking is no exception to this. Our system provides three levels of privacy: open, friends only, and closed. A feature with an open privacy level is public and may be viewed by anyone.

No. of Pages : 5 No. of Claims : 5

(12) PATENT APPLICATION PUBLICATION

(21) Application No.202241020873 A

(19) INDIA

(22) Date of filing of Application :07/04/2022

(43) Publication Date : 29/04/2022

(54) Title of the invention : SMART VEHICLE ASSISTANCE

(51) International classification :G06Q0010040000, H04W0064000000, H04W0048160000, B25H0005000000, H04Q0009000000

(86) International Application No :NA
Filing Date :NA

(87) International Publication No : NA

(61) Patent of Addition to Application Number :NA
Filing Date :NA

(62) Divisional to Application Number :NA
Filing Date :NA

(71)Name of Applicant :

1)Hindusthan College of Engineering and Technology

Address of Applicant :Hindusthan College of Engineering and Technology, Valley Campus, Pollachi Highway, Coimbatore, Tamilnadu, India 641032. -----

Name of Applicant : NA

Address of Applicant : NA

(72)Name of Inventor :

1)Dr.I.Jasmin Selvakumari Jeya

Address of Applicant :Professor & Head - IT, Hindusthan College of Engineering and Technology, Valley Campus, Pollachi Highway, Coimbatore, Tamilnadu, India 641032. -----

2)Ms.C.Jency

Address of Applicant :Assistant Professor/IT, Hindusthan College of Engineering and Technology, Valley Campus, Pollachi Highway, Coimbatore, Tamilnadu, India 641032. -----

3)Sabari Giri Vasan L

Address of Applicant :Hindusthan College of Engineering and Technology, Valley Campus, Pollachi Highway, Coimbatore, Tamilnadu, India 641032. -----

4)Subash Chandra Bose G

Address of Applicant :Hindusthan College of Engineering and Technology, Valley Campus, Pollachi Highway, Coimbatore, Tamilnadu, India 641032. -----

5)Venkatesh S

Address of Applicant :Hindusthan College of Engineering and Technology, Valley Campus, Pollachi Highway, Coimbatore, Tamilnadu, India 641032. -----

6)Yogesh K

Address of Applicant :Hindusthan College of Engineering and Technology, Valley Campus, Pollachi Highway, Coimbatore, Tamilnadu, India 641032. -----

(57) Abstract :

Annexure 3 The approach to this idea involves the perfect solution to the issues and constraints that SMART VEHICLE ASSISTANCE is going to be a good solution for the people who seek help with mechanical issues of their vehicle. Users of the Smart Vehicle Assiatance will be the registered public and they will be getting connected with the particular mechanic through the trustworthy system. Because only the legally licensed and approved mechanics are enlisted in the Smart Vehicle Assiatance (SVA) system. In an existing system there are users who have their own mechanic database which is very minimal. And also they have no idea if their vehicles are broke down or had any mechanical issue in remote locations or any long distant locations from their known mechanic shops. In an proposed Here the users of Smart Vehicle Assiatance (SVA) system can search for list of mechanic at any location or the nearby locations which will help them in an unexpected situations raised by the mechanical issues of their vehicles.

No. of Pages : 5 No. of Claims : 5

(12) PATENT APPLICATION PUBLICATION

(21) Application No.202241021447 A

(19) INDIA

(22) Date of filing of Application :11/04/2022

(43) Publication Date : 29/04/2022

(54) Title of the invention : TRAINING AND DEVELOPMENT OF EMPLOYEE TRAINING PORTAL SYSTEM

(51) International classification :G06Q0010100000, H04L0012580000, G06Q0050200000, G09B0007000000, F21V0033000000

(86) International Application No :NA
 Filing Date :NA

(87) International Publication No : NA

(61) Patent of Addition to Application Number :NA
 Filing Date :NA

(62) Divisional to Application Number :NA
 Filing Date :NA

(71)Name of Applicant :

1) HINDUSTHAN COLLEGE OF ENGINEERING AND TECHNOLOGY

Address of Applicant : HINDUSTHAN COLLEGE OF ENGINEERING AND TECHNOLOGY, VALLEY CAMPUS, POLLACHI HIGHWAY, COIMBATORE, TAMIL NADU, INDIA - 641032. -----

Name of Applicant : NA

Address of Applicant : NA

(72)Name of Inventor :

1)Dr. I. JASMINE SELVAKUMARI JEYA

Address of Applicant : PROFESSOR & HEAD-IT, HINDUSTHAN COLLEGE OF ENGINEERING AND TECHNOLOGY, VALLEY CAMPUS, POLLACHI HIGHWAY, COIMBATORE, TAMIL NADU, INDIA - 641032. -----

2)Ms.J. UMA

Address of Applicant :ASSISTANT PROFESSOR/ IT, HINDUSTHAN COLLEGE OF ENGINEERING AND TECHNOLOGY, VALLEY CAMPUS, POLLACHI HIGHWAY, COIMBATORE, TAMIL NADU, INDIA - 641032. -----

3)DHANASEKAR E

Address of Applicant :HINDUSTHAN COLLEGE OF ENGINEERING AND TECHNOLOGY, VALLEY CAMPUS, POLLACHI HIGHWAY, COIMBATORE, TAMIL NADU, INDIA - 641032. -----

4)LASHMI NARAYANAN S

Address of Applicant :HINDUSTHAN COLLEGE OF ENGINEERING AND TECHNOLOGY, VALLEY CAMPUS, POLLACHI HIGHWAY, COIMBATORE, TAMIL NADU, INDIA - 641032. -----

5)MUKILAN V

Address of Applicant :HINDUSTHAN COLLEGE OF ENGINEERING AND TECHNOLOGY, VALLEY CAMPUS, POLLACHI HIGHWAY, COIMBATORE, TAMIL NADU, INDIA - 641032. -----

6)MOULI R

Address of Applicant :HINDUSTHAN COLLEGE OF ENGINEERING AND TECHNOLOGY, VALLEY CAMPUS, POLLACHI HIGHWAY, COIMBATORE, TAMIL NADU, INDIA - 641032. -----

(57) Abstract :

.Due to this pandemic situation, most of the educational institutions as well as corporate organisations switched over-from a traditional teaching method to online method. There are various methods to teach online either through a mobile application or online portals. Though the online teaching requires internet; the best and efficient way of teaching is through the webpages which makes the content ' reachable. A webpage which helps in teaching is simply referred to as E-Learning website. Generally, E-Learning websites contains learning content as well as a space for sharing the knowledge and to solve uncertainty issues in learned concepts from the content materials. To make the above point clear, there are few websites which includes discussion forums, instant messaging simple known ' chatting tool as one of their features. The E-Learning portal helps corporate organization to train the fresher's and current employee of organization based on the project assigned to upgrade their ' . technological skills related to the assigned project from the comfort of home than the traditional ' teaching methods. The teaching from comfort of home is cost efficient and teach the employee on ' , various aspects of current and required technologies. The teaching also helps various departments to undergo the training. The training can be either of two methods, one method is teaching through a live webinar session or a live interaction session and the other method is to teach through the videos which are pre-recorded topic which acts as a reference material for the learners. The learning portal or a website may contain discussion forums or chatting tool for communication with others learners. In addition, discussion forum is made specifically for the discussion of technical and non-technical . . topics'and the chatting tool is integrated with few other features to act on its own to get a desired ' result. These E-Learning websites promotes learning from comfort of home at a desired time for the 'knowledge and skill development.

No. of Pages : 5 No. of Claims : 5

(54) Title of the invention : VOTING SYSTEM USING POLYGON BLOCK CHAIN

(51) International classification :G07C0013000000, G06Q0020380000, H04L0012260000, G06Q0040040000, G06Q0020060000

(86) International Application No :NA
Filing Date :NA

(87) International Publication No : NA

(61) Patent of Addition to Application Number :NA
Filing Date :NA

(62) Divisional to Application Number :NA
Filing Date :NA

(71)Name of Applicant :**1)Hindusthan College of Engineering and Technology**

Address of Applicant :Hindusthan College of Engineering and Technology, Valley Campus, Pollachi Highway, Coimbatore, Tamilnadu, India 641032. -----

Name of Applicant : NA**Address of Applicant : NA****(72)Name of Inventor :****1)Dr.I.Jasmin Selvakumari Jeya**

Address of Applicant :Professor & Head - IT, Hindusthan College of Engineering and Technology, Valley Campus, Pollachi Highway, Coimbatore, Tamilnadu, India 641032. -----

2)Mr.S.Karthic

Address of Applicant :Assistant Professor/ IT, Hindusthan College of Engineering and Technology, Valley Campus, Pollachi Highway, Coimbatore, Tamilnadu, India 641032. -----

3)Ms. T. Sakthi Shree

Address of Applicant :Assistant Professor/ IT, Hindusthan College of Engineering and Technology, Valley Campus, Pollachi Highway, Coimbatore, Tamilnadu, India 641032. -----

4)Rakshan T

Address of Applicant :Hindusthan College of Engineering and Technology, Valley Campus, Pollachi Highway, Coimbatore, Tamilnadu, India 641032. -----

5)Ruban Kumar B

Address of Applicant :Hindusthan College of Engineering and Technology, Valley Campus, Pollachi Highway, Coimbatore, Tamilnadu, India 641032. -----

6)Raguram T

Address of Applicant :Hindusthan College of Engineering and Technology, Valley Campus, Pollachi Highway, Coimbatore, Tamilnadu, India 641032. -----

(57) Abstract :

Annexure 3 Online voting is an alternative to age old paper ballot system and the currently popular electronic voting machines (EVM). An electronic voting portal should offer security and integrity along with the transparency of votes and privacy of voters. This paper proposes an e-voting system based on block chain that eliminates some of the limitations in existing voting systems. The paper also presents state of art of some block chain frameworks for e-voting. The presented implementation is suitable for Small scale elections like inside corporate houses, board rooms etc. The Implementation uses smart contract from Ethereum on polygon network. Thirdweb framework is used in this paper for development, testing and deploying smart contracts. Here Meta-mask is used as browser wallet and we use rinkeby test network to test our application. Polygon, formerly known as Matic Network, is a block chain scalability platform and framework for connecting and building block chain networks compatible with Ethereum. The network also refers to itself as Ethereum's internet of Block chains because one of Polygon's main missions is aggregating scalable solutions to support a multichain Ethereum ecosystem. The Polygon network is Ethereum-native, aligned to be interoperable with all of Ethereum's existing and even future infrastructures while offering a framework for its interoperability with other layer-2 solutions, side chains and sovereign block chains. The Polygon network is thus also categorized as a layer-2 aggregator, aiming to create a multichain ecosystem of Ethereum-compatible block chains with superior interoperability.

No. of Pages : 5 No. of Claims : 5